

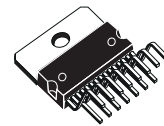

5W+5W AMPLIFIER WITH DC VOLUME CONTROL

- 5+5W OUTPUT POWER
 $R_L = 8\Omega$ @THD = 10% $V_{CC} = 22V$
- ST-BY AND MUTE FUNCTIONS
- LOW TURN-ON TURN-OFF POP NOISE
- LINEAR VOLUME CONTROL DC COUPLED WITH POWER OP. AMP.
- NO BOUCHEROT CELL
- NO ST_BY RC INPUT NETWORK
- SINGLE SUPPLY RANGING UP TO 35V
- SHORT CIRCUIT PROTECTION
- THERMAL OVERLOAD PROTECTION
- INTERNALLY FIXED GAIN
- SOFT CLIPPING
- VARIABLE OUTPUT AFTER VOLUME CONTROL CIRCUIT
- MULTIWATT 15 PACKAGE

MULTIPOWER BI50II TECHNOLOGY



Multiwatt 15
ORDERING NUMBER: TDA7496

plifier assembled in the @ Multiwatt 15 package, specially designed for high quality sound, TV applications.

Features of the TDA7496 include linear volume control Stand-by and Mute functions.

The TDA7496 is pin to pin compatible with TDA7496S, TDA7496SA, TDA7495, TDA7495SA, TDA7494S, TDA7494SA.

DESCRIPTION

The TDA7496 is a stereo 5+5W class AB power am-

BLOCK DIAGRAM

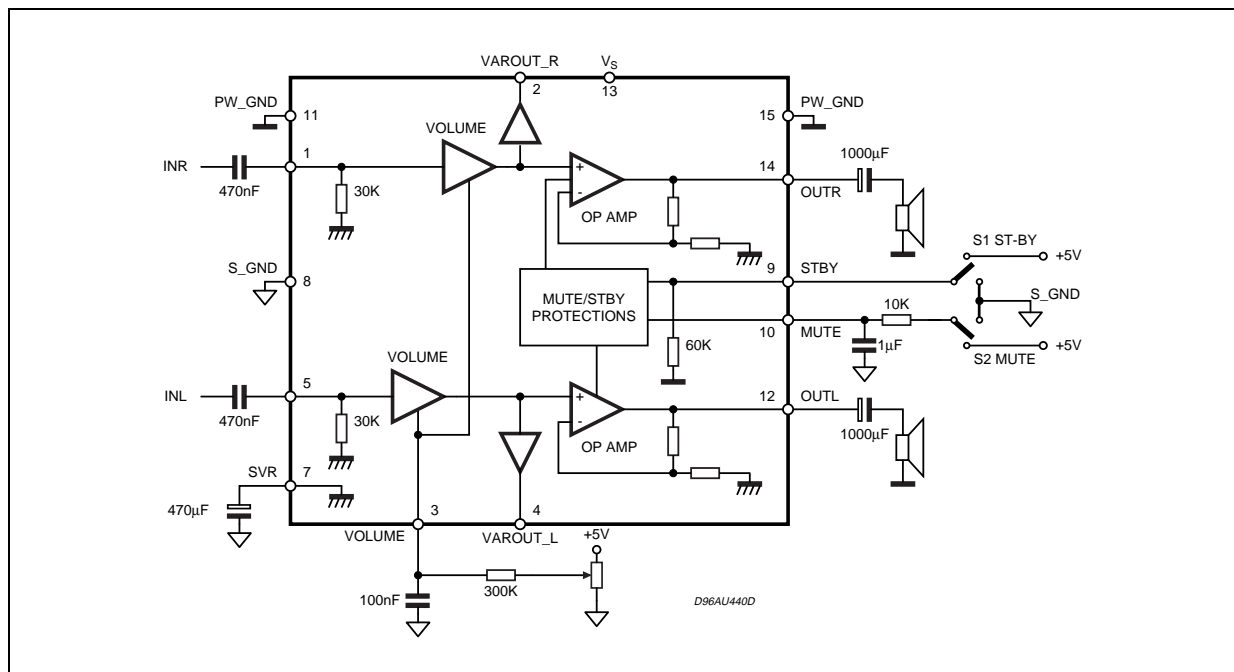

TDA7496

ABSOLUTE MAXIMUM RATINGS

Symbol	Parameter	Value	Unit
V_S	DC Supply Voltage	35	V
V_{IN}	Maximum Input Voltage	8	V _{pp}
P_{tot}	Total Power Dissipation ($T_{amb} = 80^{\circ}C$)	15	W
T_{amb}	Ambient Operating Temperature (1)	0 to 70	$^{\circ}C$
T_{stg}, T_J	Storage and Junction Temperature	-40 to 150	$^{\circ}C$
V_3	Volume Control DC Voltage	7	V

PIN CONNECTION (top view)

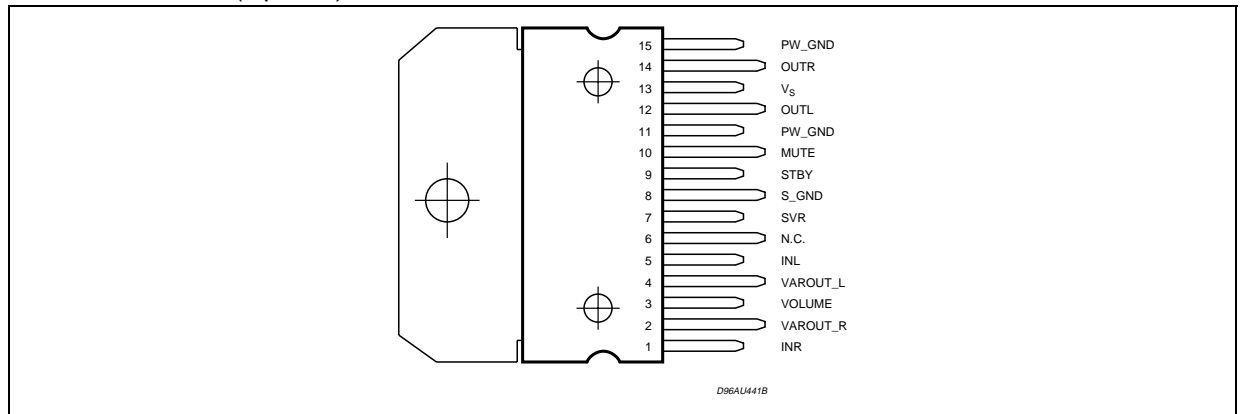

THERMAL DATA

Symbol	Parameter	Value	Unit
$R_{th\ j-case}$	Thermal Resistance junction-case	Typ. = 4; Max. = 4.6	$^{\circ}C/W$
$R_{th\ j-amb}$	Thermal Resistance junction-ambient Max.	35	$^{\circ}C/W$

ELECTRICAL CHARACTERISTICS

(Refer to the test circuit $V_S = 22V$; $R_L = 8\Omega$, $R_G = 50\Omega$, $T_{amb} = 25^{\circ}C$)

Symbol	Parameter	Test Condition	Min.	Typ.	Max.	Unit
V_S	Supply Voltage Range		10		32	V
I_q	Total Quiescent Current			25	50	mA
DCV_{os}	Output DC Offset Referred to SVR Potential	No Input Signal		200		mV
V_O	Quiescent Output Voltage			11		V
P_O	Output Power	THD = 10%; $R_L = 8\Omega$; THD = 1%; $R_L = 8\Omega$;	5	5.5 4		W
		THD = 10%; $R_L = 4\Omega$; $V_S = 12V$ THD = 1%; $R_L = 4\Omega$; $V_S = 12V$		2.1 1.0		W
THD	Total Harmonic Distortion	$G_V = 30dB$; $P_O = 1W$; $f = 1KHz$			0.4	%

ELECTRICAL CHARACTERISTICS (continued)(Refer to the test circuit $V_S = 22V$; $R_L = 8\Omega$, $R_G = 50\Omega$, $T_{amb} = 25^\circ C$)

Symbol	Parameter	Test Condition	Min.	Typ.	Max.	Unit
I_{peak}	Output Peak Current	(internally limited)	1.0	1.3		A
V_{IN}	Input Signal				2.8	V _{rms}
G_V	Closed Loop Gain	$V_{OI\ Ctrl} > 4.5V$	28.5	30	31.5	dB
G_{VLine}	Monitor Out Gain	$V_{OI\ Ctrl} > 4.5V$; $Z_{load} > 30K\Omega$	-1.5	0	1.5	dB
$A_{Min\ VOL}$	Attenuation at Minimum Volume	$V_{OI\ Ctrl} < 0.5V$	80			dB
BW				0.6		MHz
e_N	Total Output Noise	$f = 20Hz$ to $22KHz$ PLAY, max volume		500	800	μV
		$f = 20Hz$ to $22KHz$ PLAY, max attenuation		100	250	μV
		$f = 20Hz$ to $22KHz$ MUTE		60	150	μV
SR	Slew Rate		5	8		V/ μs
R_i	Input Resistance		22.5	30		K Ω
$R_{Var\ Out}$	Variable Output Resistance			30	100	Ω
$R_{L\ Var\ Out}$	Variable Output Load		2			K Ω
SVR	Supply Voltage Rejection	$f = 1KHz$; max volume $C_{SVR} = 470\mu F$; $V_{RIP} = 1V_{rms}$	35	39		dB
		$f = 1KHz$; max attenuation $C_{SVR} = 470\mu F$; $V_{RIP} = 1V_{rms}$	55	65		dB
T_M	Thermal Muting			150		$^\circ C$
T_S	Thermal Shut-down			160		$^\circ C$
MUTE & INPUT SELECTION FUNCTIONS						
V_{ST-ON}	Stand-by ON Threshold		3.5			V
V_{ST-OFF}	Stand-by OFF Threshold				1.5	V
V_{MUTEON}	Mute ON threshold		3.5			V
$V_{MUTEOFF}$	Mute OFF threshold				1.5	V
A_{MUTE}	Mute Attenuation		50	65		dB
I_{qST-BY}	Quiescent Current @ Stand-by			0.6	1	mA
$I_{stbyBIAS}$	Stand-by bias current	Stand by ON: $V_{ST-BY} = 5V$; $V_{mute} = 5V$		80		μA
		Play or Mute	-20	-5		μA
$I_{muteBIAS}$	Mute Bias Current	Mute		1	5	μA
		Play		0.2	2	μA

APPLICATION SUGGESTIONS

The recommended values of the external components are those shown on the application circuit of figure 1. Different values can be used, the following table can help the designer.

COMPONENT	SUGGESTION VALUE	PURPOSE	LARGER THAN SUGGESTION	SMALLER THAN SUGGESTION
R1	300K	Volume Control Circuit	Larger volume regulation time	Smaller volume regulation time
R2	10K	Mute time constant	Larger mute on/off time	Smaller mute on/off time
P1	50K	Volume Control Circuit		
C1	1000µF	Supply voltage bypass		Danger of oscillation
C2	470nF	Input DC decoupling	Lower low frequency cutoff	Higher low frequency cutoff
C3	470nF	Input DC decoupling	Lower low frequency cutoff	Higher low frequency cutoff
C4	470µF	Ripple rejection	Better SVR	Worse SVR
C5	100nF	Volume control time constant	Larger volume regulation time	Smaller volume regulation time
C6	1000µF	Output DC decoupling	Lower low frequency cutoff	Higher low frequency cutoff
C7	1µF	Mute time constant	Larger mute on/off time	Smaller mute on/off time
C8	1000µF	Output DC decoupling	Lower low frequency cutoff	Higher low frequency cutoff
C9	100nF	Supply voltage bypass		Danger of oscillation

Figure 1. Application Circui

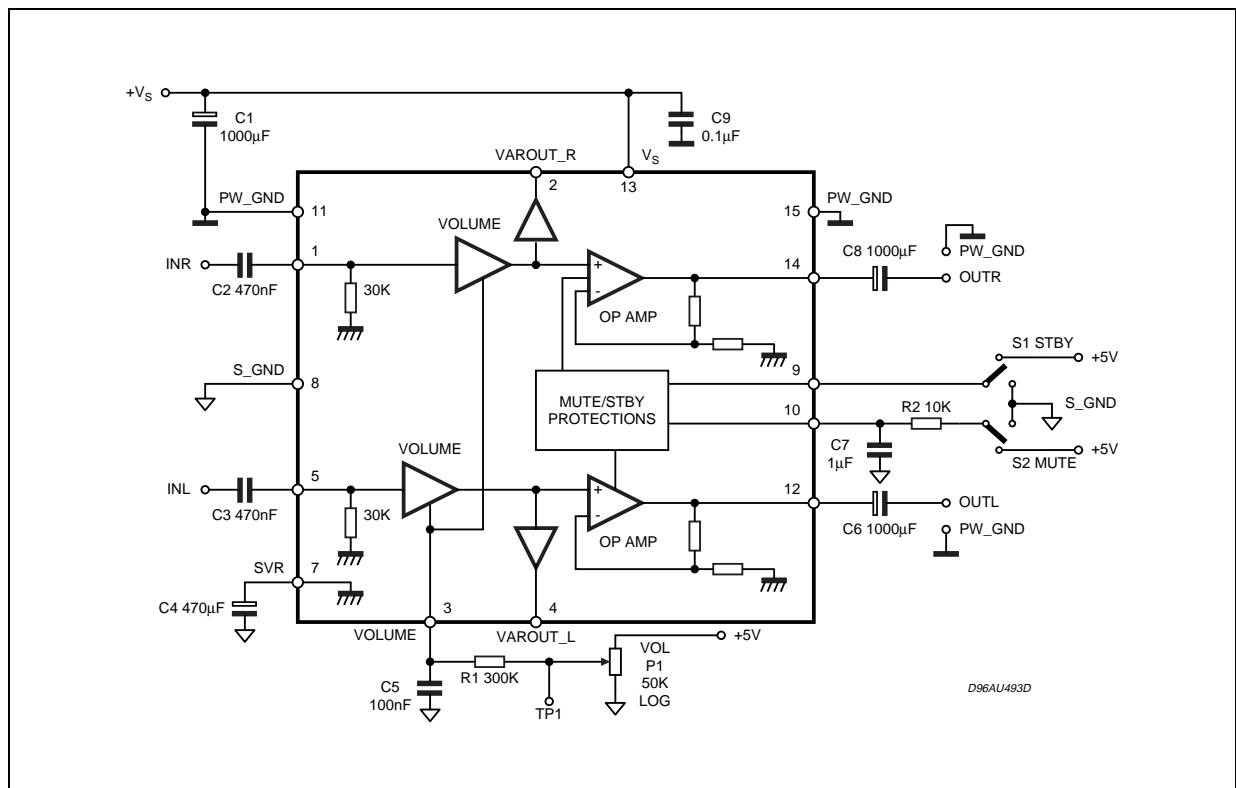

MUTE STAND-BY TRUTH TABLE

MUTE	St-BY	OPERATING CONDITION
H	H	STAND-BY
L	H	STAND-BY
H	L	MUTE
L	L	PLAY

Turn ON/OFF Sequences (for optimizing the POP performances)

Figure 1. USING ONLY THE MUTE FUNCTION

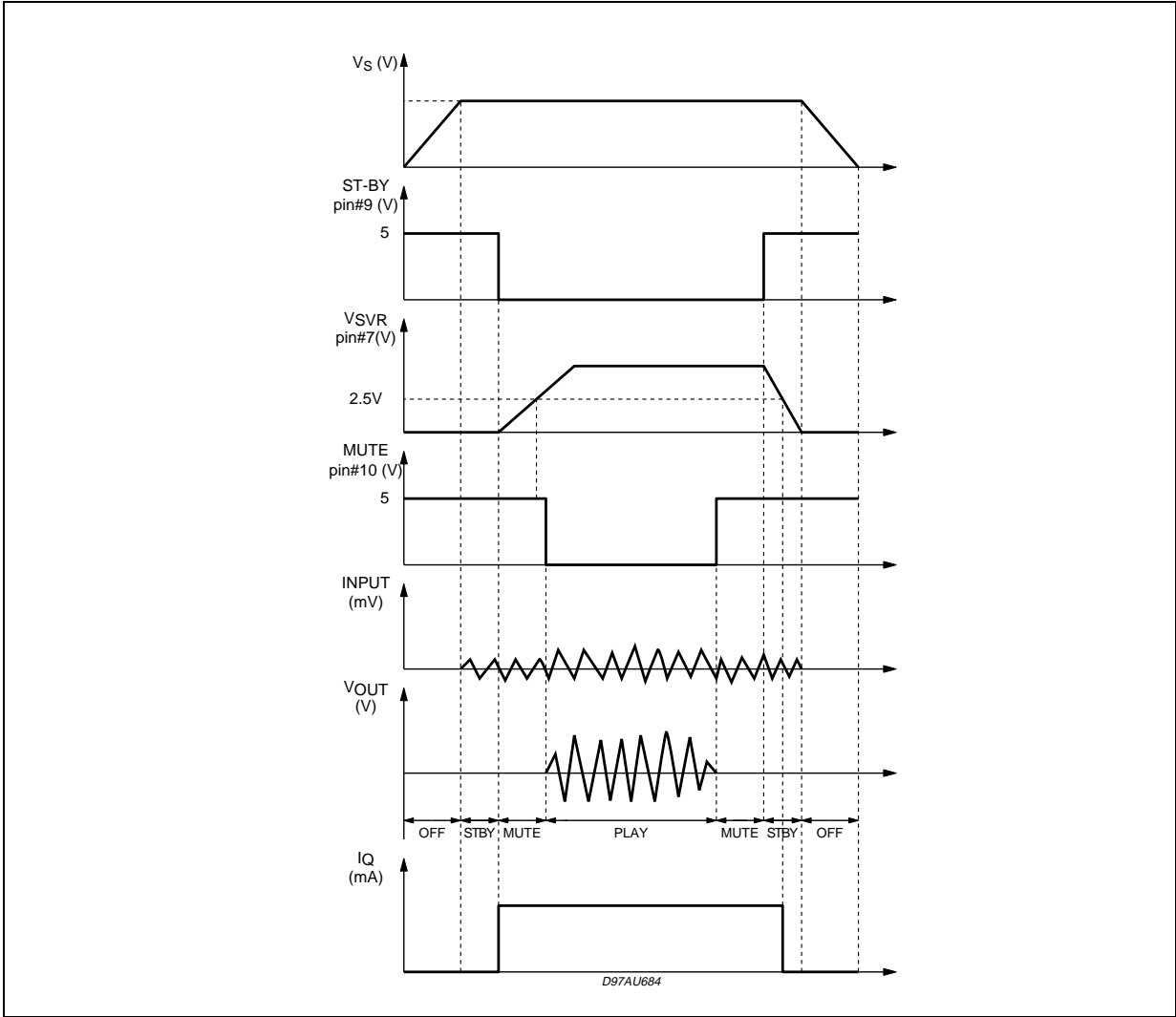

USING ONLY THE MUTE FUNCTION

To simplify the application, the stand-by pin can be connected directly to Ground. During the ON/OFF transitions is recommended to respect the following conditions:

- At the turn-on the transition mute to mute - play must be made when the SVR pin is higher than 2.5V
- At the turn-off the TDA7496 must be brought to mute from the play condition when the SVR pin is higher than 2.5V.

Figure 2. P.C.B. and Component layout PCB and Component Layout

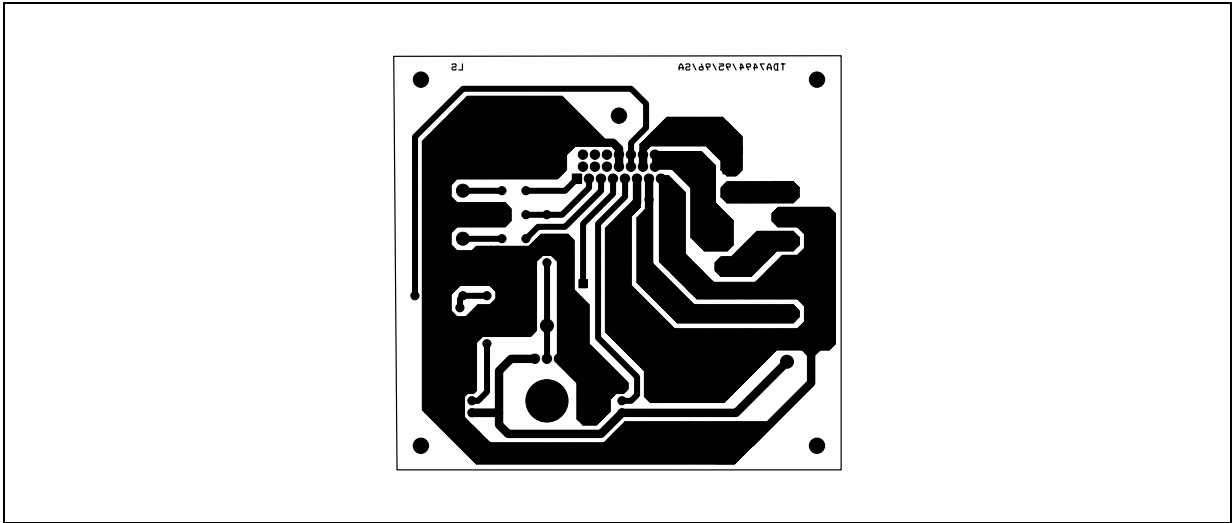

Figure 3.

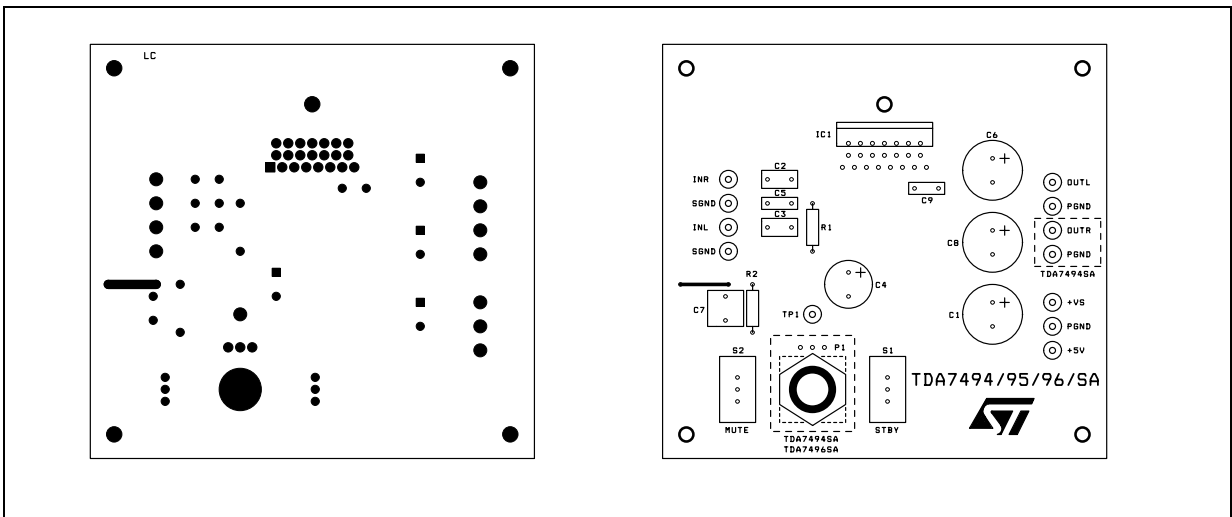

Figure 4. Quiescent Current vs. Supply Voltage

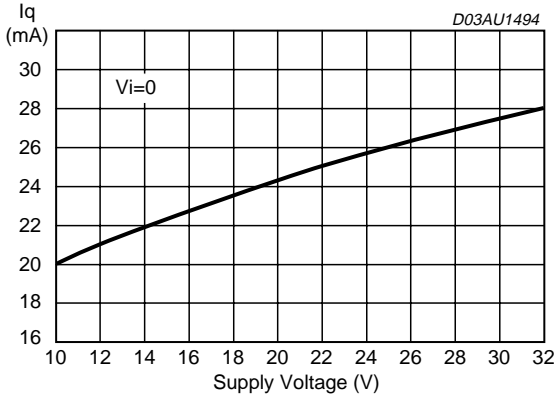

Figure 7. Output DC Offset vs. Supply Voltage

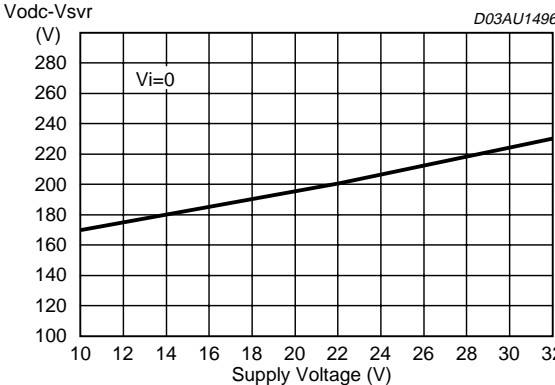

Figure 5. Output Dc Offset vs. Supply Voltage

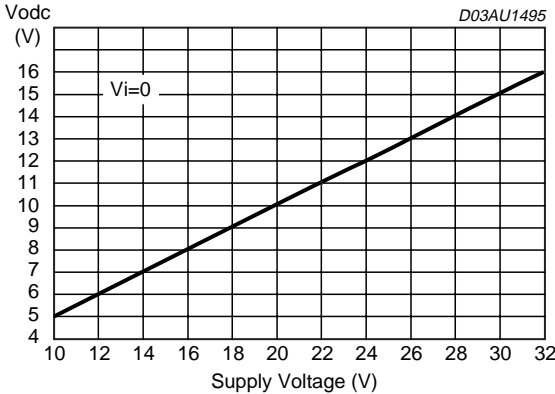

Figure 8. Output Power vs Supply Voltage

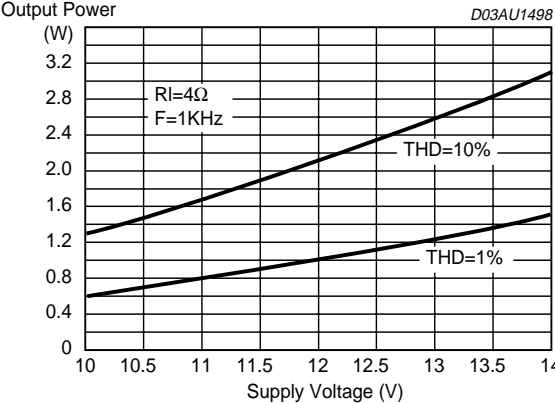

Figure 6. Output Power vs. Supply Voltage

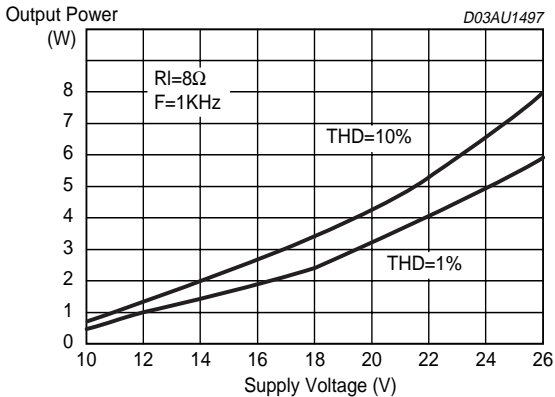

Figure 9. Distortion vs Output Power

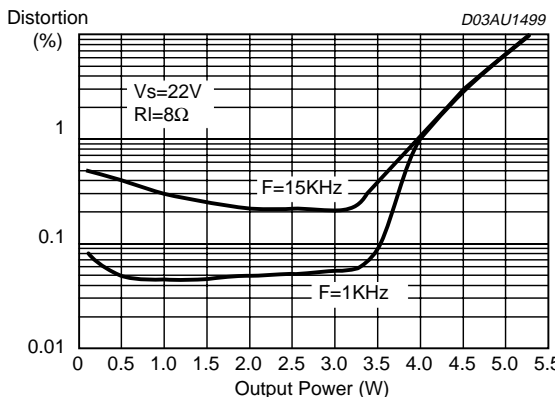

Figure 10. Distortion vs Output Power

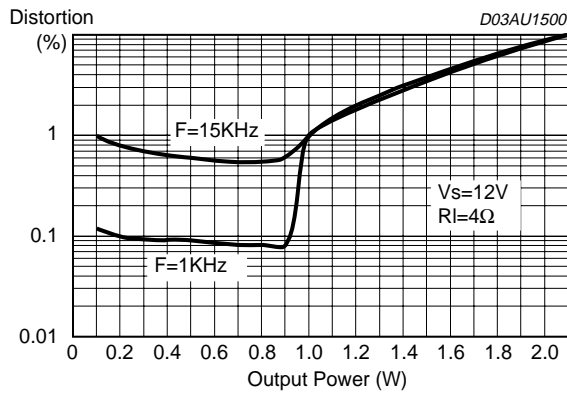

Figure 11. Closed Loop Gain vs. Frequency

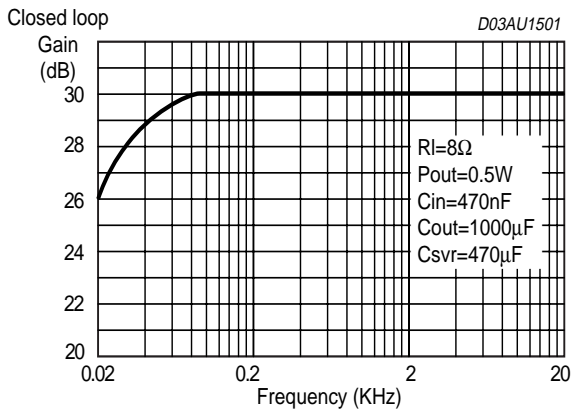

Figure 12. St-By Attenuation vs Vpin 9

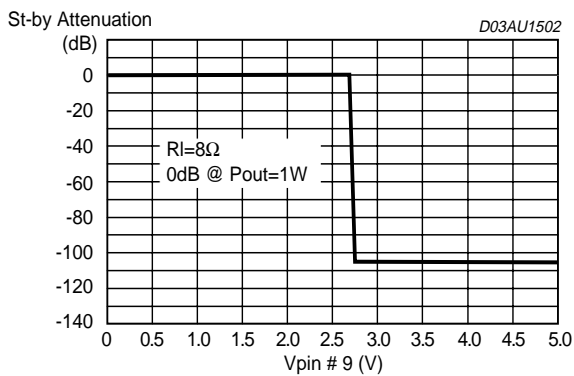
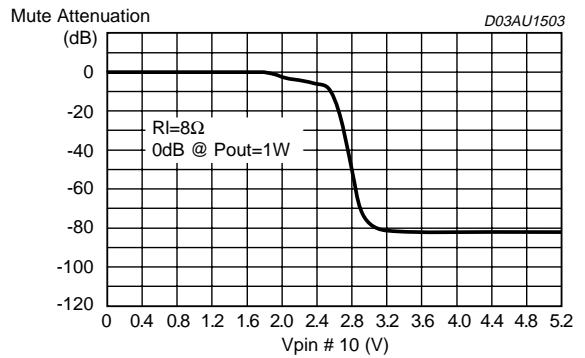

Figure 13. Mute Attenuation vs Vpin 10



PINS DESCRIPTION

Figure 14. PIN SVR

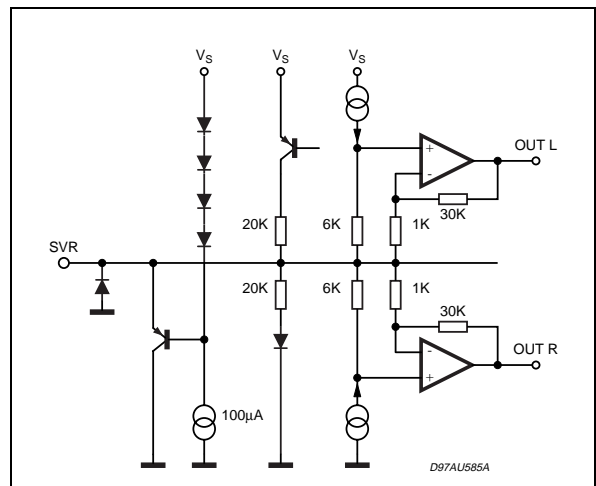

Figure 15. PINS: INL, INR

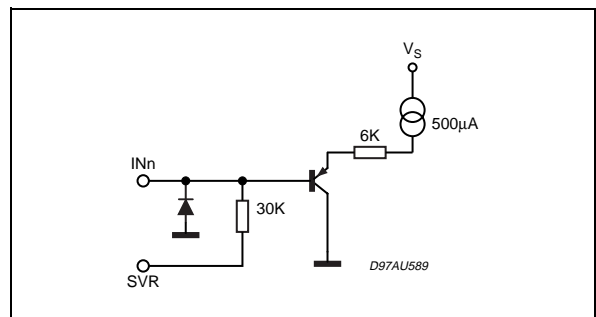

Figure 17. PIN ST-BY

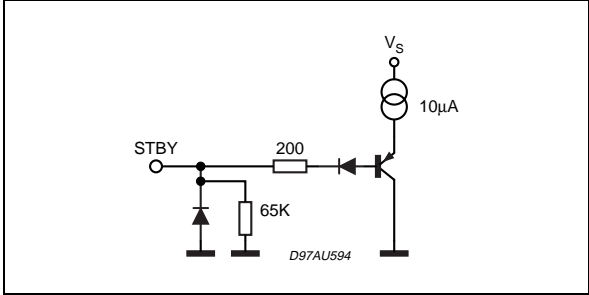

Figure 18. PIN: MUTE

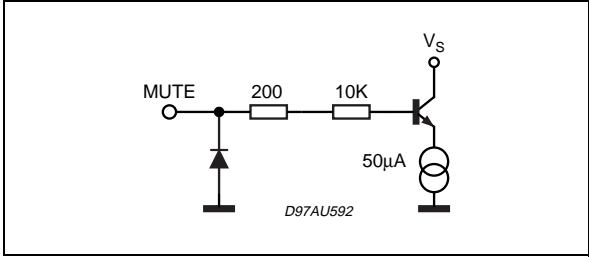

Figure 19. PINS: OUT R, OUT L

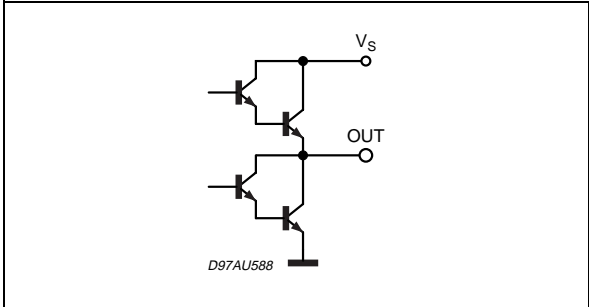

Figure 20. PINS: VAROUT-L VAROUT-R

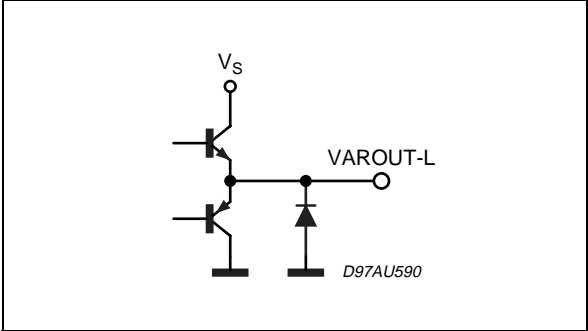

Figure 21. PIN: VOLUME

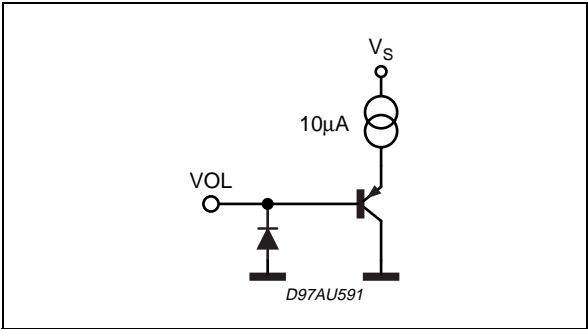
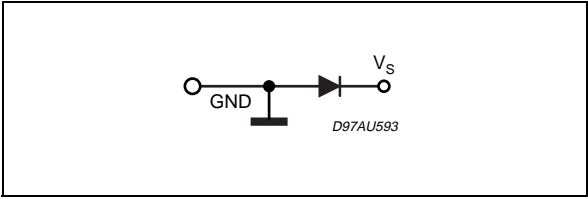
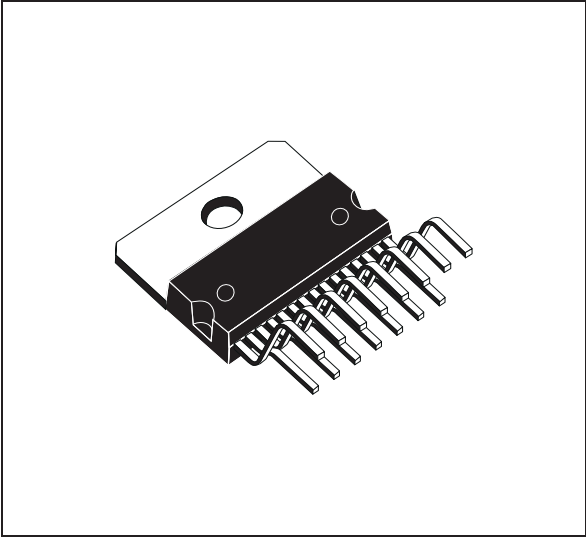

Figure 22. PINS: PW-GND, S-GND



DIM.	mm			inch		
	MIN.	TYP.	MAX.	MIN.	TYP.	MAX.
A			5			0.197
B			2.65			0.104
C			1.6			0.063
D		1			0.039	
E	0.49		0.55	0.019		0.022
F	0.66		0.75	0.026		0.030
G	1.02	1.27	1.52	0.040	0.050	0.060
G1	17.53	17.78	18.03	0.690	0.700	0.710
H1	19.6			0.772		
H2			20.2			0.795
L	21.9	22.2	22.5	0.862	0.874	0.886
L1	21.7	22.1	22.5	0.854	0.870	0.886
L2	17.65		18.1	0.695		0.713
L3	17.25	17.5	17.75	0.679	0.689	0.699
L4	10.3	10.7	10.9	0.406	0.421	0.429
L7	2.65		2.9	0.104		0.114
M	4.25	4.55	4.85	0.167	0.179	0.191
M1	4.63	5.08	5.53	0.182	0.200	0.218
S	1.9		2.6	0.075		0.102
S1	1.9		2.6	0.075		0.102
Dia1	3.65		3.85	0.144		0.152

OUTLINE AND MECHANICAL DATA



Multiwatt15 V

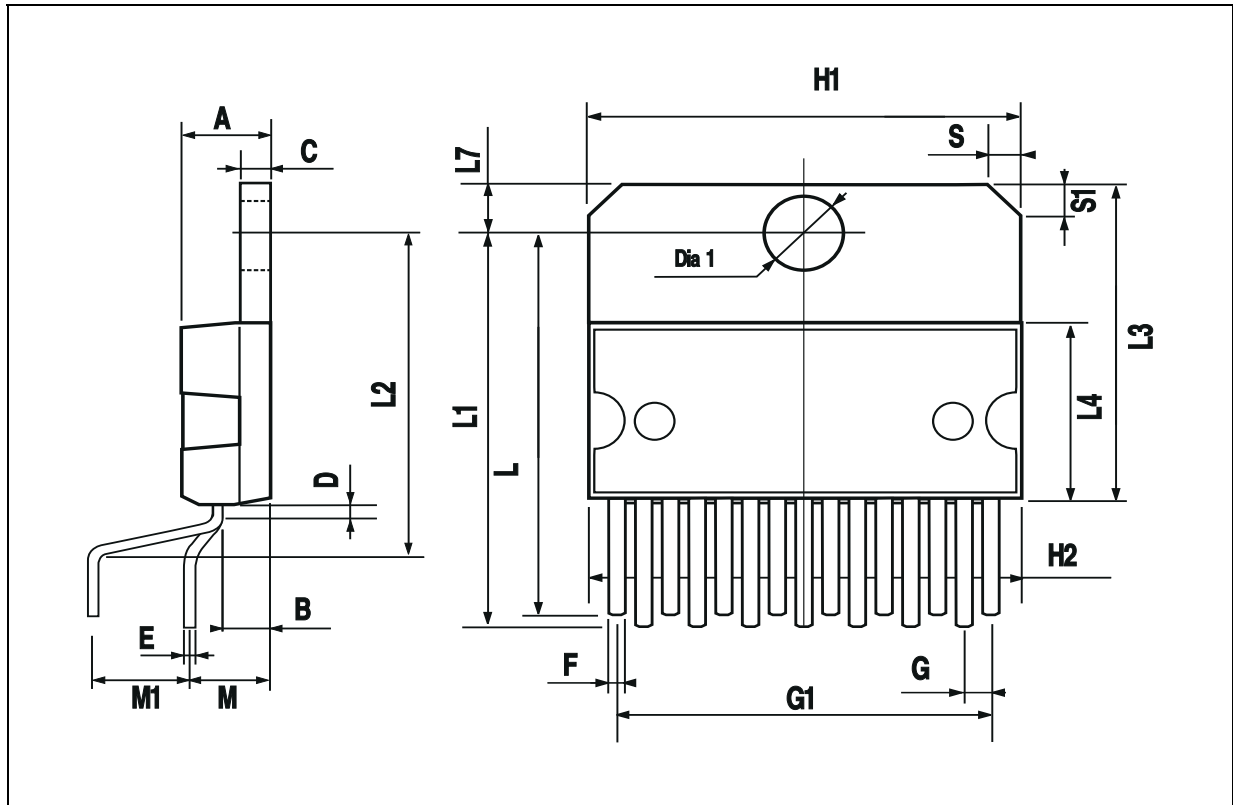

Information furnished is believed to be accurate and reliable. However, STMicroelectronics assumes no responsibility for the consequences of use of such information nor for any infringement of patents or other rights of third parties which may result from its use. No license is granted by implication or otherwise under any patent or patent rights of STMicroelectronics. Specifications mentioned in this publication are subject to change without notice. This publication supersedes and replaces all information previously supplied. STMicroelectronics products are not authorized for use as critical components in life support devices or systems without express written approval of STMicroelectronics.

The ST logo is a registered trademark of STMicroelectronics.
All other names are the property of their respective owners

© 2003 STMicroelectronics - All rights reserved

STMicroelectronics GROUP OF COMPANIES

Australia - Belgium - Brazil - Canada - China - Czech Republic - Finland - France - Germany - Hong Kong - India - Israel - Italy - Japan -
Malaysia - Malta - Morocco - Singapore - Spain - Sweden - Switzerland - United Kingdom - United States
www.st.com



X-ON Electronics

Largest Supplier of Electrical and Electronic Components

Click to view similar products for [Audio Amplifiers](#) category:

Click to view products by [STMicroelectronics](#) manufacturer:

Other Similar products are found below :

[LV47002P-E](#) [NCP2811AFCT1G](#) [NCP2890AFCT2G](#) [SSM2377ACBZ-R7](#) [IS31AP4915A-QFLS2-TR](#) [NCP2820FCT2G](#) [TDA1591T](#)
[TDA7563AH](#) [SSM2529ACBZ-R7](#) [SSM2518CBZ-R7](#) [MAX9890AETA+T](#) [TS2012EIJT](#) [NCP2809BMUTXG](#) [NJW1157BFC2](#)
[SSM2375CBZ-REEL7](#) [IS31AP4996-GRLS2-TR](#) [STPA002OD-4WX](#) [NCP2823BFCT1G](#) [MAX9717DETA+T](#) [MAX9717CETA+T](#)
[MAX9724AEBC+TG45](#) [LA4450L-E](#) [IS31AP2036A-CLS2-TR](#) [MAX9723DEBE+T](#) [TDA7563ASMTR](#) [AS3561-DWLT](#) [SSM2517CBZ-R7](#)
[MP1720DH-12-LF-P](#) [SABRE9601K](#) [THAT1646W16-U](#) [MAX98396EWB+](#) [PAM8965ZLA40-13](#) [BD37532FV-E2](#) [BD5638NUX-TR](#)
[BD37512FS-E2](#) [BD37543FS-E2](#) [BD3814FV-E2](#) [TPA3140D2PWPR](#) [TS2007EIJT](#) [IS31AP2005-DLS2-TR](#) [SSM2518CPZ-R7](#) [AS3410-EQFP-](#)
[500](#) [FDA4100LV](#) [MAX98306ETD+T](#) [TS4994EIJT](#) [NCP2820FCT1G](#) [NCP2823AFCT2G](#) [NCS2211MNTXG](#) [CPA2233CQ16-A1](#)
[OPA1604AIPWR](#)