

TDE1707BFP

PIN CONNECTION (Top view)

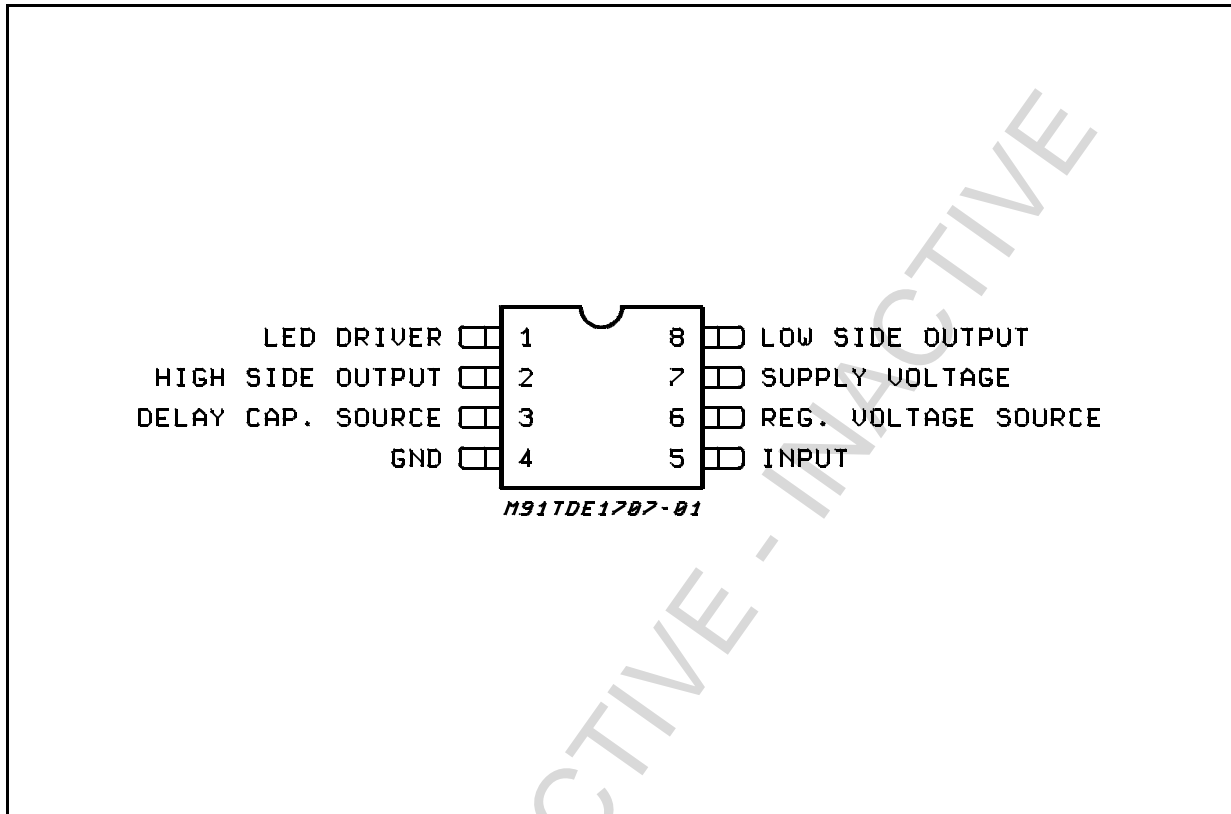

ABSOLUTE MAXIMUM RATINGS

| Symbol | Parameter | Value | Unit |
|-------------|-----------------------------|--------------------|------|
| V_S | Supply Voltage | 50 | V |
| V_{Sr} | Supply Reverse Voltage | 50 | V |
| I_O | Output Current | internally limited | A |
| V_{reg} | Regulated Voltage Pin | 0 to 7 | V |
| V_{delay} | Delay Cap. Surce Pin | 0 to 5 | V |
| V_O | Output Diff. Voltage | 55 | V |
| V_i | Input Voltage | -10 to 50 | V |
| T_{op} | Operating Temperature Range | -25 to +85 | °C |
| T_{stg} | Storage Temperature | -55 to 150 | °C |
| P_{tot} | Power Dissipation | internally limited | W |
| E_i | Energy Induct. Load | 150 | mJ |

THERMAL DATA

| Symbol | Description | Value | Unit |
|-----------------|-------------------------------------|----------|------|
| $R_{th\ j-amb}$ | Thermal Resistance Junction-ambient | Max. 150 | °C/W |

ELECTRICAL CHARACTERISTICS ($V_S = 24V$; $T_J = -25$ to $+85^\circ C$, unless otherwise specified)

| Symbol | Parameter | Test Condition | Min. | Typ. | Max. | Unit |
|---------------|-------------------------------|--|------|------|------------|--------------------|
| V_S 7 | Supply Voltage | | 6 | | 48 | V |
| I_{SR} 7 | Supply Reverse Current | $V_{SR} = -48V$ | | | 1.5 | mA |
| I_q 7 | Quiescent Current | $I_{reg} = I_{led} = 0$; $V_i < 2V$; $V_S = 6$ to $48V$ | | | 1.5 | mA |
| I_o 8/2 | Output Current | $V_S = 6V$ to $32V$ | | | 500 | mA |
| I_o 8/2 | Output Current | $V_S = 32V$ to $48V$ | | | 300 | mA |
| V_{sat} 8/2 | Output Voltage Drop V_{8-2} | $I_o = 500mA$ | | 1.1 | 1.6 | V |
| V_{sat} 8/2 | Output Voltage Drop V_{8-2} | $I_o = 300mA$ | | | 1.5 | V |
| I_{sc} 8/2 | Short Circuit Current | | 0.7 | | 1.5 | A |
| V_{cl} 8/2 | Internal Voltage Clamp | $I_{CL} = 10mA$ | 55 | | 70 | V |
| I_{olk} 8/2 | Output Leakage | (Pin 2) $V_i < 2V$; $V_o = 0$ to V_S (Pin 8) | | 100 | 300 100 | μA μA |
| V_{ith} 5 | Input Voltage Threshold | | 2 | | 3 | V |
| V_{ihis} 5 | Input Threshold Hysteresis | | | 300 | | mV |
| I_{lk} 5 | Input Current | $V_i = 5V$ | | 2 | 5 | μA |
| V_{reg} 6 | Regulated Output Voltage | $I_{reg} < 5mA$ | 4.5 | 5 | 5.5 | V |
| I_{scr} 6 | Short Circuit Regulated | | 6 | 30 | 50 | mA |
| I_{reg} 6 | Output Regulator Current | $V_S = 35V$ $V_S = 48V$ | | | 6 4 | mA mA |
| I_{old} 1 | Current Surce Sink Led Driver | Output ON (\pm) | 2 | 3 | 4 | mA |
| V_{old} 1 | Voltage Drop Led Driver | $I_{os} = 2mA$ (\pm) | | 1.2 | 1.6 | V |
| I_{oldk} 1 | Lead Driver (off) Leak. | $V_i < 2V$; $R_L < 1K\Omega$ | | | 10 | μA |
| I_{dch} 3 | Del. Cap. Charge Current | $T_J = 25^\circ C$ | 2 | 4 | 6 | μA |
| V_{dth} 3 | Delay Voltage Trigger | $T_J = 25^\circ C$ | | 4 | | V |

APPLICATION INFORMATION (See Application Circuit)

The LED driver tells the output status. It can source or sink current ($I_{old\ typ} = 3mA$), according to the output configuration chosen. The thresholds, represented by the output comparator in the Block Diagram, are set at about 1.5V - 2V.

For instance, in the High Side Load case of the

Application Circuit, when the voltage on pin 8 (the output) differs from V_{CC} less than 1.5V, the output is sensed in "OFF" state and the LED driver is disabled.

If instead pin 8 differs from V_{CC} more than 3V (the output comparator threshold value plus the drop voltage on the LED), then the output is sensed "ON" and the driver will force the current on the LED.

DYNAMIC CHARACTERISTICS ($V_S = 24V$; $R_L = 48\Omega$; $T_J = 25^\circ C$)

| | | | | | | |
|--------------|--|-------------------|------|----|---|---------|
| t_{on} | Propagation Turn on Time | $V_i = 0$ to $5V$ | | 15 | | μs |
| t_{off} | Propagation Turn off Time | $V_i = 5$ to $0V$ | | 15 | | μs |
| t_{don} | Delayed Turn on Time / nF Delay Capacitor | | 0.65 | 1 | 2 | ms |
| $t_{d\ min}$ | Minimum Delayed t_{on} Delay Capacitor = 0 | | | 25 | | μs |

APPLICATION CIRCUIT

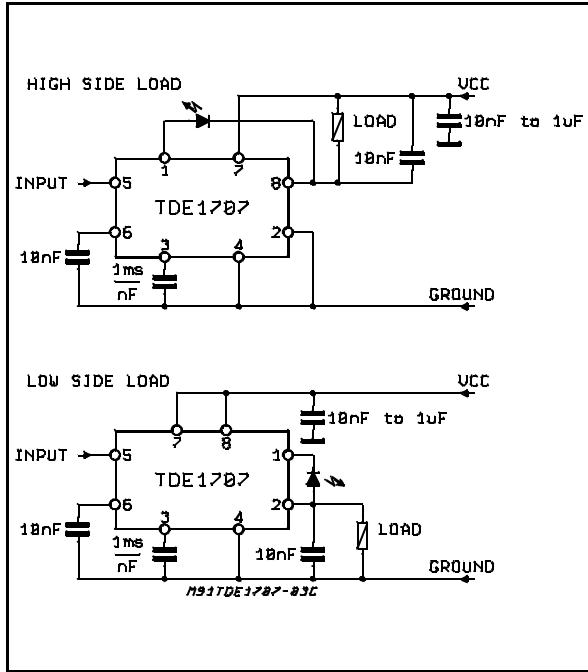

Figure 1: Input Thresholds Voltage vs. Temperature ($V_s = 24V$)

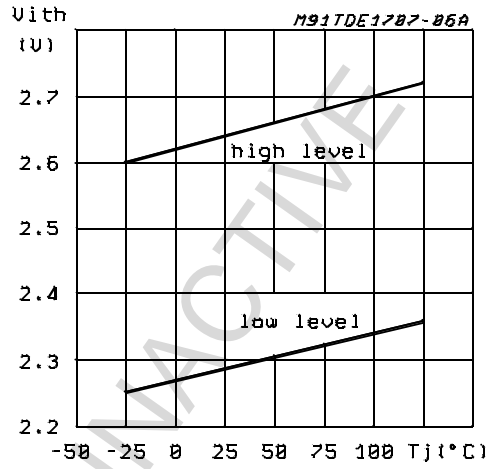

Figure 2: Saturation Voltage vs. Temperature ($V_s = 24V$; $I_o = 500mA$)

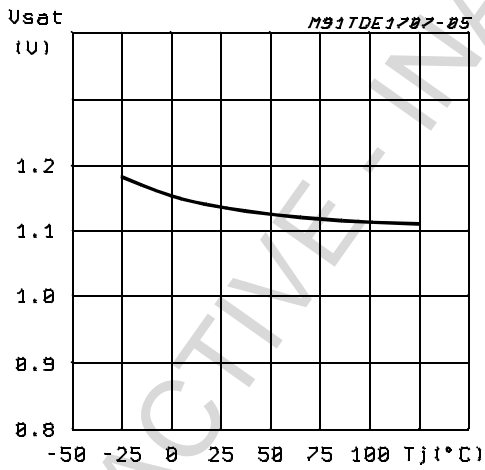
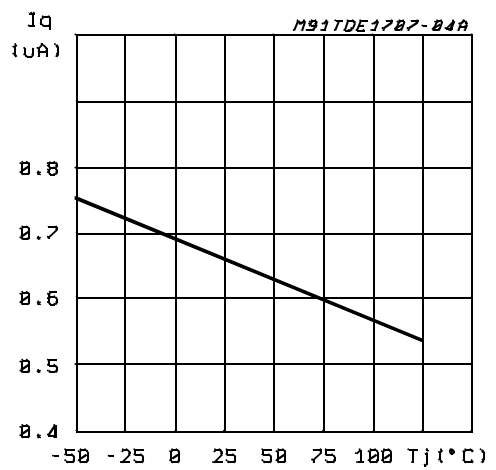
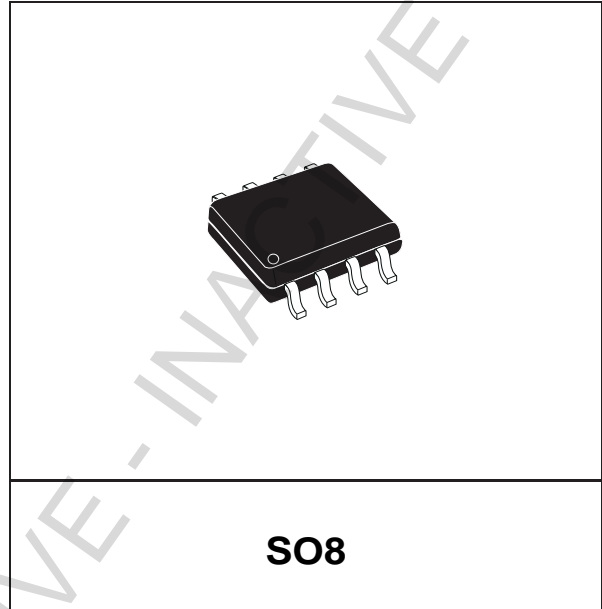

Figure 3: Quiescent Current vs. Temperature ($V_s = 24V$)



| DIM. | mm | | | inch | | |
|-------|------------|------|------|-------|-------|-------|
| | MIN. | TYP. | MAX. | MIN. | TYP. | MAX. |
| A | | | 1.75 | | | 0.069 |
| a1 | 0.1 | | 0.25 | 0.004 | | 0.010 |
| a2 | | | 1.65 | | | 0.065 |
| a3 | 0.65 | | 0.85 | 0.026 | | 0.033 |
| b | 0.35 | | 0.48 | 0.014 | | 0.019 |
| b1 | 0.19 | | 0.25 | 0.007 | | 0.010 |
| C | 0.25 | | 0.5 | 0.010 | | 0.020 |
| c1 | 45° (typ.) | | | | | |
| D (1) | 4.8 | | 5.0 | 0.189 | | 0.197 |
| E | 5.8 | | 6.2 | 0.228 | | 0.244 |
| e | | 1.27 | | | 0.050 | |
| e3 | | 3.81 | | | 0.150 | |
| F (1) | 3.8 | | 4.0 | 0.15 | | 0.157 |
| L | 0.4 | | 1.27 | 0.016 | | 0.050 |
| M | | | 0.6 | | | 0.024 |
| S | 8° (max.) | | | | | |

OUTLINE AND MECHANICAL DATA



(1) D and F do not include mold flash or protrusions. Mold flash or protrusions shall not exceed 0.15mm (.006inch).

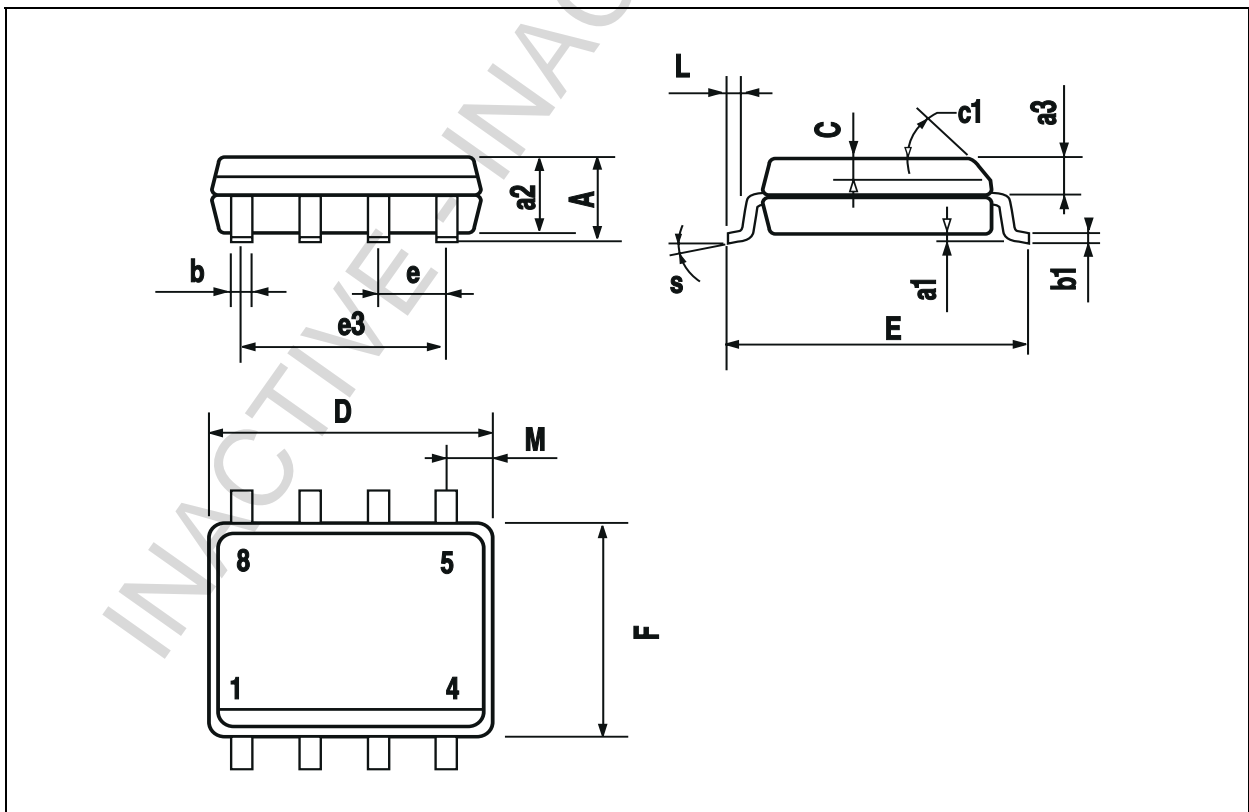

Information furnished is believed to be accurate and reliable. However, STMicroelectronics assumes no responsibility for the consequences of use of such information nor for any infringement of patents or other rights of third parties which may result from its use. No license is granted by implication or otherwise under any patent or patent rights of STMicroelectronics. Specifications mentioned in this publication are subject to change without notice. This publication supersedes and replaces all information previously supplied. STMicroelectronics products are not authorized for use as critical components in life support devices or systems without express written approval of STMicroelectronics.

The ST logo is a registered trademark of STMicroelectronics.
All other names are the property of their respective owners

© 2003 STMicroelectronics - All rights reserved

STMicroelectronics GROUP OF COMPANIES

Australia – Belgium - Brazil - Canada - China – Czech Republic - Finland - France - Germany - Hong Kong - India - Israel - Italy - Japan - Malaysia - Malta - Morocco - Singapore - Spain - Sweden - Switzerland - United Kingdom - United States

www.st.com

X-ON Electronics

Largest Supplier of Electrical and Electronic Components

Click to view similar products for [Power Switch ICs - Power Distribution](#) *category:*

Click to view products by [STMicroelectronics](#) *manufacturer:*

Other Similar products are found below :

[TCK111G,LF\(S](#) [FPF1018](#) [DS1222](#) [TCK2065G,LF](#) [SZNCP3712ASNT3G](#) [MIC2033-05BYMT-T5](#) [MIC2033-12AYMT-T5](#) [MIC2033-05BYM6-T5](#) [SLG5NT1437VTR](#) [SZNCP3712ASNT1G](#) [DML1008LDS-7](#) [KTS1670EDA-TR](#) [KTS1640QGDV-TR](#) [KTS1641QGDV-TR](#) [NCV459MNWTBG](#) [FPF2260ATMX](#) [U6513A](#) [MIC2012YM-TR](#) [NCP45780IMN24RTWG](#) [MAX14919ATP+](#) [MC33882PEP](#) [TPS2104DBVR](#) [MIC2098-1YMT-TR](#) [MIC94062YMT TR](#) [MP6231DN-LF](#) [MIC2015-1.2YM6 TR](#) [MIC2075-2YM](#) [MIC94068YML-TR](#) [SIP32461DB-T2-GE1](#) [NCP335FCT2G](#) [TCK105G,LF\(S](#) [AP2411S-13](#) [AP2151DSG-13](#) [MIC94094YC6-TR](#) [MIC94093YC6-TR](#) [MIC94064YC6-TR](#) [MIC2505-1YM](#) [MIC94305YMT-TR](#) [MIC94085YFT-TR](#) [MIC94081YFT-TR](#) [MIC94042YFL-TR](#) [MIC94041YFL-TR](#) [MIC2005-1.2YM6-TR](#) [TPS2032QDRQ1](#) [NCP333FCT2G](#) [BTS3050TFATMA1](#) [NCP331SNT1G](#) [TPS2092DR](#) [TPS2063DR](#) [TPS2042P](#)