



TL7700A Series

SUPPLY VOLTAGE SUPERVISORS

- POWER-ON RESET GENERATOR
- AUTOMATIC RESET GENERATION AFTER VOLTAGE DROP
- WIDE SUPPLY VOLTAGE RANGE ... 3V TO 18V
- PRECISION VOLTAGE SENSOR
- TEMPERATURE-COMPENSATED VOLTAGE REFERENCE
- TRUE AND COMPLEMENT RESET OUTPUTS
- EXTERNALLY ADJUSTABLE PULSE WIDTH

DESCRIPTION

The TL7700A series are monolithic supply voltage supervisor IC's specifically designed for use as reset controllers in microcomputer and microprocessor systems. During power-up the device tests the supply voltage and keeps the RESET and RESET outputs active (high and low, respectively) as long as the supply voltage has not reached its nominal voltage value. Taking RESIN low has the same effect. To ensure that the microcomputer system has reset, the TL7700A then initiates an internal time count that delays the return of the reset outputs to their inactive states. Since the time delay for most microcomputers and microprocessors is in the order of several machine cycles, the device internal time delay is determined by an external capacitor connected to the C_T input (pin 3).

$$t_{po} = 1.3 \times 10^4 \times C_T$$

Where: C_T is in farads (F) and t_{po} in seconds (s). In addition, when the supply voltage drops below the nominal value, the outputs will be active until the supply voltage returns to the nominal value. An external capacitor (typically 0.1 μF) must be connected to the REF output (pin 1) to reduce the influence of fast transients in the supply voltage.

The TL7700AI series is characterized for operation from -25°C to 85°C; the TL7700AC series is characterized from 0°C to 70°C.

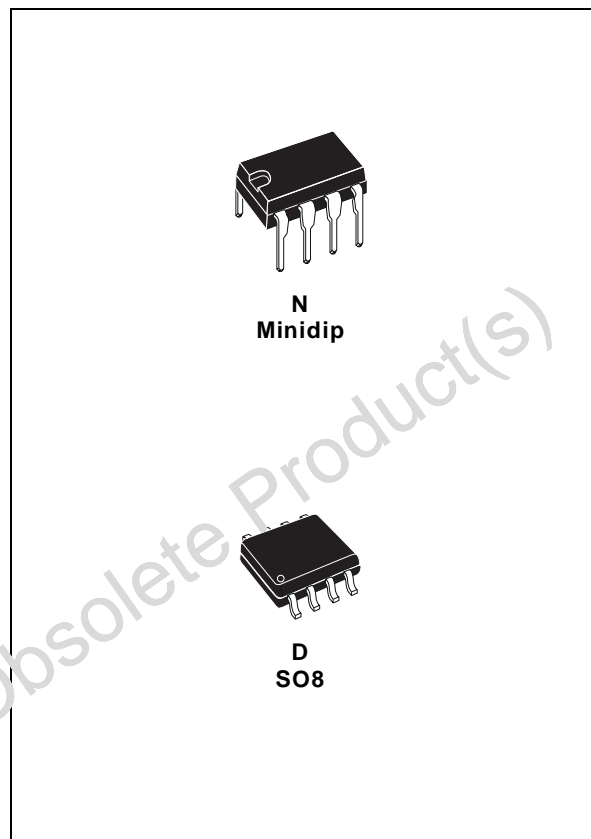

ORDERING NUMBERS

Temperature Range	Minidip	S08
0 to 70°C	TL77XXACP	TL77XXACD
-25 to 85°C	TL77XXAIP	TL77XXAID

PIN CONNECTION (top view)

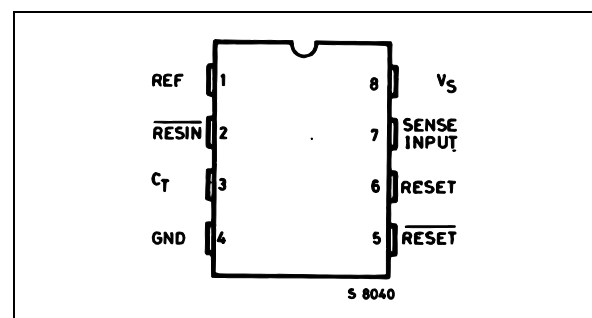

TL7700A Series

BLOCK DIAGRAM

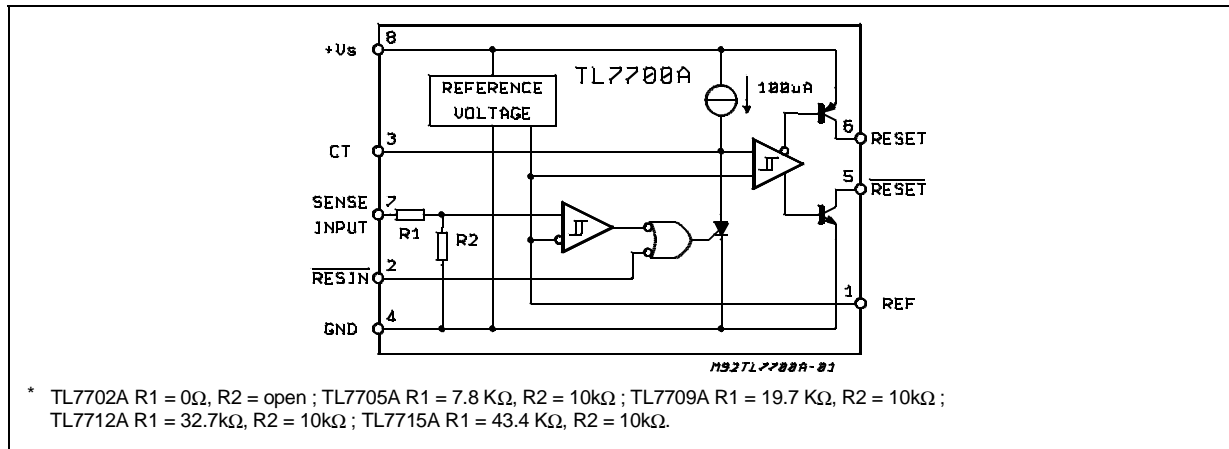

ABSOLUTE MAXIMUM RATINGS

Symbol	Parameter	Value	Unit
V_s	Supply Voltage, V_{CC} - (see note 1)	20	V
V_i	Input Voltage Range at \overline{RESIN}	-0.3 to 20	V
V_i	Input Voltage at SENSE : TL7702A (see note 2) TL7705A	-0.3 to 6 -0.3 to 10	V
I_{OH}	High-level Output Current at \overline{RESET}	-30	mA
I_{OL}	Low-level Output Current at \overline{RESET}	30	mA
T_{amb}	Operating Free-air Temperature Range : TL77XXAI TL77XXAC	-25 to 85 0 to 70	°C
T_{stg}	Storage Temperature Range	-65 to 150	°C

- Notes :**
- All voltage values are with respect to the network ground terminal
 - For the TL7700A, the voltage applied to the SENSE terminal must never exceed V_s .

THERMAL DATA

Symbol	Parameter	Value	Unit
$R_{th\ j-amb}$	Thermal Resistance Junction-ambient Max.	120	°C/W

RECOMMENDED OPERATING CONDITIONS

Symbol	Parameter	Min.	Max.	Unit
V_s	Supply Voltage	3.6	18	V
V_{IH}	High-level Input Voltage at \overline{RESIN}	2		V
V_{IL}	Low-level Input Voltage at \overline{RESIN}		0.6	V
V_i	Voltage at Sense Input TL7702A TL7705A	0 0	See note 3 10	V
I_{OH}	High-level Output Current at \overline{RESET}		-16	mA
I_{OL}	Low-level Output Current at \overline{RESET}		16	mA
T_{amb}	Operating Free-air Temperature Range TL77-AI TL77-AC	-25 0	85 70	°C

- Note :**
- For proper operation of the TL7702A, the voltage applied to the SENSE terminal should not exceed $V_s - 1V$ or $6V$, whichever is less.

ELECTRICAL CHARACTERISTICS these specifications unless otherwise specified, apply for :
 $T_{amb} = -25$ to 85°C (TLXXAI), $T_{amb} = 0$ to 70°C (TL77XXAC)

Symbol	Parameter	Test Conditions (1)	Min.	Typ.	Max.	Unit
V_{OH}	High-level Output Voltage at RESET	$I_{OH} = -16\text{mA}$	$V_s - 1.5$			V
V_{OL}	Low-Level Output Voltage at RESET	$I_{OL} = 16\text{mA}$		0.4		V
V_{ref}	Reference Voltage	$T_{amb} = 25^{\circ}\text{C}$	2.48	2.53	2.58	V
V_T	Threshold Voltage at SENSE Input	TL7702A TL7705A $V_s = 3.6\text{V to }18\text{V}$ $T_{amb} = 25^{\circ}\text{C}$	2.48 4.5	2.53 4.55	2.58 4.6	V
V_T	Threshold Voltage at SENSE Input	TL7702A TL7705A $V_s = 3.6\text{V to }18\text{V}$	2.45 4.45	2.53 4.55	2.58 4.6	V
V_{T+}, V_{T-}	Hysteresis (2) at SENSE Input	TL7702A TL7705A $V_s = 3.6\text{V to }18\text{V}$ $T_{amb} = 25^{\circ}\text{C}$		10 15		mV
I_i	Input Current at RESIN Input	$V_i = 2.4\text{V to }V_s$ $V_i = 0.4\text{V}$		20 -100		μA
I_i	Input Current at SENSE Input	TL7702A $V_{ref} < V_i < V_s - 1.5\text{V}$		0.5	2	μA
I_{OH}	High-level Output Current at RESET	$V_O = 18\text{V}$		50		μA
I_{OL}	Low-level Output Current at RESET	$V_O = 0\text{V}$		-50		μA
I_s	Supply Current	All Inputs and out. open		1.8	3.3	mA

- Notes :**
- All characteristics are measured with $C = 0.1\mu\text{F}$ from Pin 1 to GND, and with $C = 0.1\mu\text{F}$ from Pin 3 to GND.
 - Hysteresis is the difference between the positive going input threshold voltage, V_{T+} , and the negative going input threshold voltage, V_{T-} .

SWITCHING CHARACTERISTICS

Symbol	Parameter	Test Conditions	Min.	Typ.	Max.	Unit
t_{pi}	Pulse Width at SENSE Input	$V_{ih} = V_{ityp} + 0.04 \times V_i$ $V_{il} = V_{ityp} - 0.04 \times V_i$	0.9			μs
t_{pi}	Pulse Width at RESIN Input		0.4			μs
t_{po}	Pulse Width at Output	$C_T = 0.1\mu\text{F}$	0.65	1.3	2.6	ms
t_{pdHL}	Propagation Delay Time from RESIN to RESET	$C_L = 100\text{pF}$, $V_s = 5\text{V}$, $R_L = 4.7\text{k}\Omega$			1	μs
$t_{r/f}$	Rise/Falltime at RESET and RESET	$C_L = 10\text{pF}$, $V_s = 5\text{V}$, $R_L = 4.7\text{k}\Omega$			1	μs

Figure 1 : Reset Controller for μ P

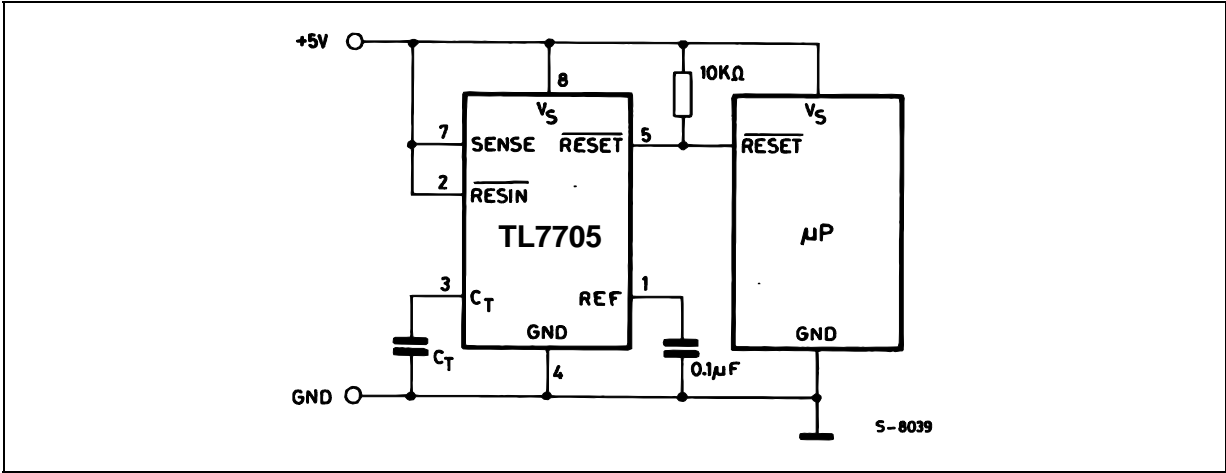

DIM.	mm			inch		
	MIN.	TYP.	MAX.	MIN.	TYP.	MAX.
A			1.75			0.069
a1	0.1		0.25	0.004		0.010
a2			1.65			0.065
a3	0.65		0.85	0.026		0.033
b	0.35		0.48	0.014		0.019
b1	0.19		0.25	0.007		0.010
C	0.25		0.5	0.010		0.020
c1	45° (typ.)					
D (1)	4.8		5.0	0.189		0.197
E	5.8		6.2	0.228		0.244
e		1.27			0.050	
e3		3.81			0.150	
F (1)	3.8		4.0	0.15		0.157
L	0.4		1.27	0.016		0.050
M			0.6			0.024
S	8° (max.)					

OUTLINE AND MECHANICAL DATA

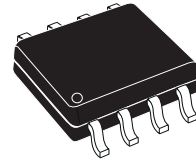

SO8

(1) D and F do not include mold flash or protrusions. Mold flash or protrusions shall not exceed 0.15mm (.006inch).

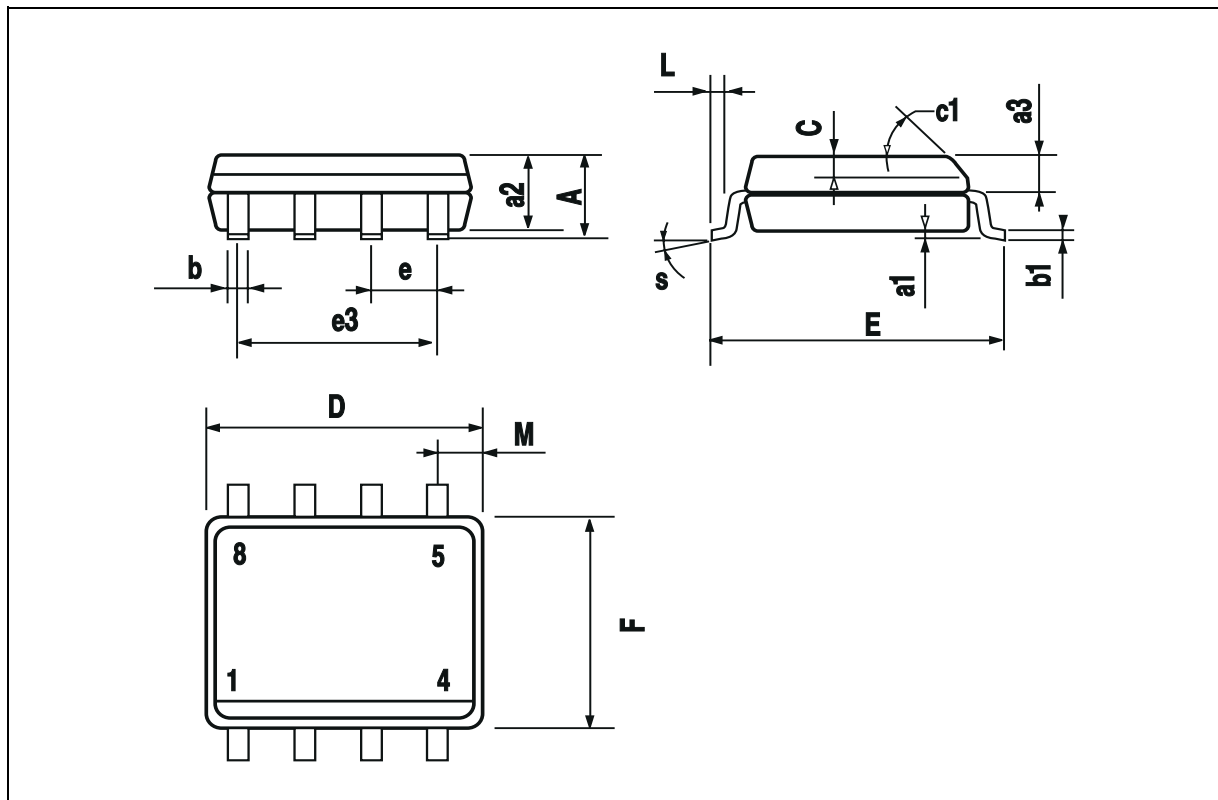

TL7700A Series

DIM.	mm			inch		
	MIN.	TYP.	MAX.	MIN.	TYP.	MAX.
A		3.32			0.131	
a1	0.51			0.020		
B	1.15		1.65	0.045		0.065
b	0.356		0.55	0.014		0.022
b1	0.204		0.304	0.008		0.012
D			10.92			0.430
E	7.95		9.75	0.313		0.384
e		2.54			0.100	
e3		7.62			0.300	
e4		7.62			0.300	
F			6.6			0.260
I			5.08			0.200
L	3.18		3.81	0.125		0.150
Z			1.52			0.060

OUTLINE AND MECHANICAL DATA

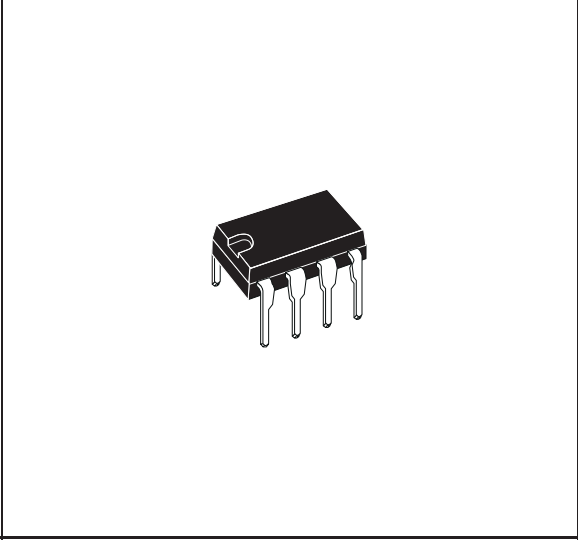

Minidip

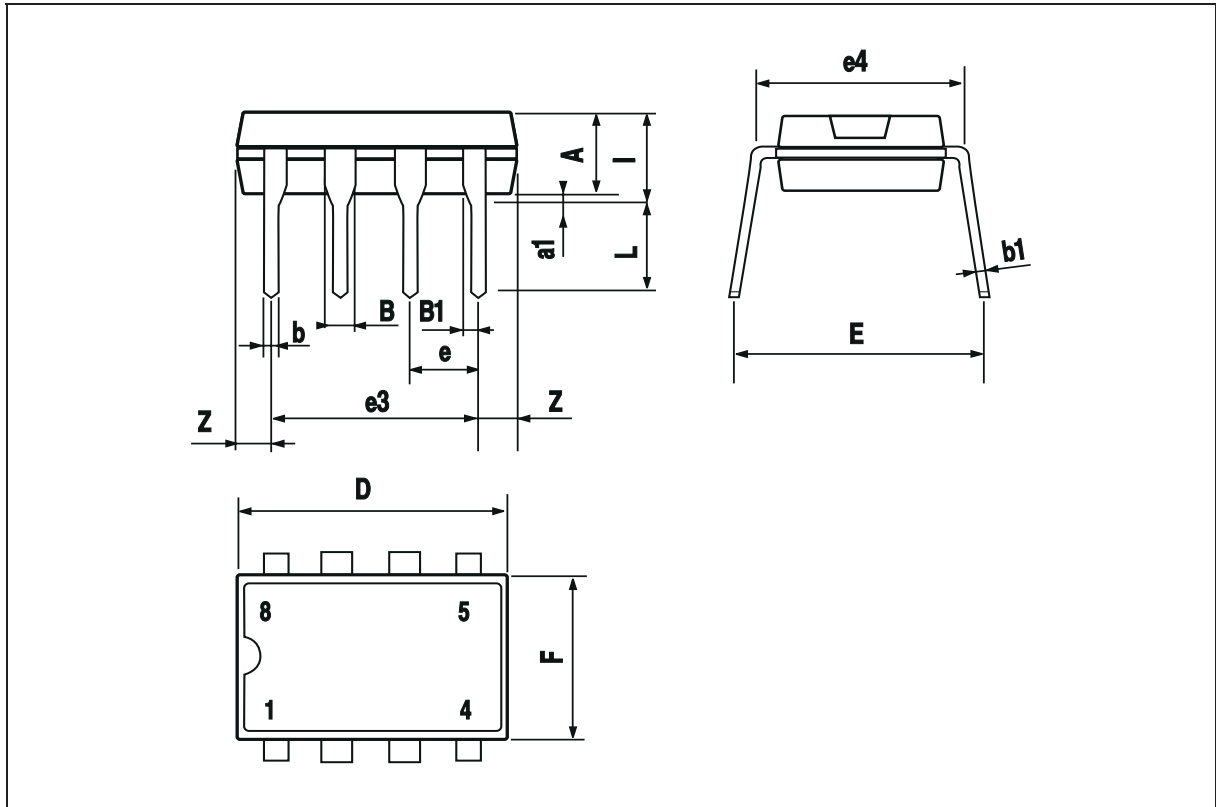

Information furnished is believed to be accurate and reliable. However, STMicroelectronics assumes no responsibility for the consequences of use of such information nor for any infringement of patents or other rights of third parties which may result from its use. No license is granted by implication or otherwise under any patent or patent rights of STMicroelectronics. Specification mentioned in this publication are subject to change without notice. This publication supersedes and replaces all information previously supplied. STMicroelectronics products are not authorized for use as critical components in life support devices or systems without express written approval of STMicroelectronics.

The ST logo is a registered trademark of STMicroelectronics
© 2000 STMicroelectronics – Printed in Italy – All Rights Reserved
STMicroelectronics GROUP OF COMPANIES

Australia - Brazil - China - Finland - France - Germany - Hong Kong - India - Italy - Japan - Malaysia - Malta - Morocco -
Singapore - Spain - Sweden - Switzerland - United Kingdom - U.S.A.

<http://www.st.com>

X-ON Electronics

Largest Supplier of Electrical and Electronic Components

Click to view similar products for [Supervisory Circuits](#) category:

Click to view products by [STMicroelectronics](#) manufacturer:

Other Similar products are found below :

[NCP304LSQ38T1G](#) [NCP304LSQ42T1G](#) [NCP304LSQ43T1G](#) [NCP305LSQ11T1G](#) [NCP305LSQ16T1G](#) [NCP305LSQ17T1G](#)
[NCP305LSQ18T1G](#) [NCP305LSQ24T1G](#) [NCP305LSQ25T1G](#) [NCP305LSQ29T1G](#) [NCP305LSQ31T1G](#) [NCP305LSQ32T1G](#)
[NCP308MT250TBG](#) [NCP308SN300T1G](#) [NCP391FCALT2G](#) [NCV303LSN42T1G](#) [CAT1161LI-25-G](#) [CAT853STBI-T3](#) [CAT1026LI-30-G](#)
[CAT1320LI-25-G](#) [CAT872-30ULGT3](#) [NCP304HSQ18T1G](#) [NCP304HSQ29T1G](#) [NCP304LSQ27T1G](#) [NCP304LSQ29T1G](#)
[NCP304LSQ45T1G](#) [NCP305LSQ26T1G](#) [NCP305LSQ35T1G](#) [NCP305LSQ37T1G](#) [NCP308MT300TBG](#) [NCV300LSN36T1G](#)
[NCV302LSN30T1G](#) [NCV303LSN16T1G](#) [NCV303LSN22T1G](#) [NCV303LSN27T1G](#) [NCV33161DMR2G](#) [TC54VN2402EMB713](#)
[MCP1316T-44NE/OT](#) [MCP1316MT-45GE/OT](#) [MCP1316MT-23LI/OT](#) [MCP1316T-26LE/OT](#) [MAX8997EWW+](#) [MAX821RUS+T](#)
[MAX6725AKASYD3-LF-T](#) [MAX809SEUR](#) [MAX6701LKA+](#) [MAX16126TCA+T](#) [MAX16046ATN+](#) [NCP303LSN09T2G](#)
[NCP304LSQ20T1G](#)