

## Adjustable shunt voltage reference

Datasheet - production data

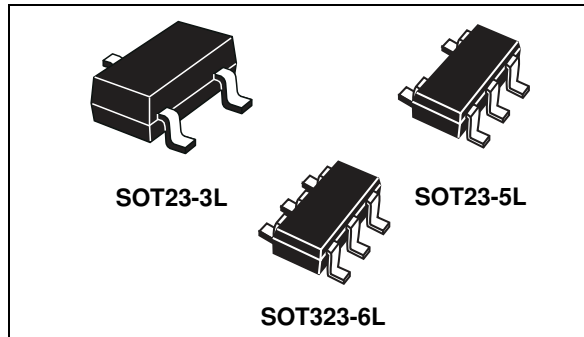

### Features

- Adjustable output voltage: 1.24 V to 18 V
- Low operating current: 100  $\mu$ A at 25  $^{\circ}$ C
- 0.25%, 0.5%, 1% and 1.5% voltage precision
- Sink current capability up to 60 mA
- -40 to +125  $^{\circ}$ C temperature range
- 100 ppm/ $^{\circ}$ C maximum temperature coefficient
- Available in SOT23-3L, SOT23-5L and SOT323-6L packages

### Applications

- Computers

- Battery chargers
- Switch mode power supplies
- Battery operated equipment
- Data acquisition systems
- Energy management

### Description

The TLVH431 is a low power adjustable shunt voltage reference, with guaranteed temperature stability over the entire operating temperature range.

The output voltage may be set to any value between 1.24 V and 18 V by means of an external resistor divider.

The TLVH431 operates with a wide current range from 100  $\mu$ A to 60 mA with a typical dynamic impedance of 0.22  $\Omega$ .

Available in SOT23-3L, SOT23-5L and SOT323-6L surface mounted packages, it can be designed in applications where space saving is a critical issue.

The low operating current is a key advantage for power restricted designs.

Table 1. Device summary

| Part number  | Precision | Marking | Package   | Temperature range        |
|--------------|-----------|---------|-----------|--------------------------|
| TLVH431AIL3T | 0.5%      | H43A    | SOT23-3L  | -40 to +125 $^{\circ}$ C |
| TLVH431BIL3T | 0.25%     | H43B    |           |                          |
| TLVH431MIL3T | 1%        | 43L     |           |                          |
| TLVH431LIL3T | 1.5%      | 43L     |           |                          |
| TLVH431AIL5T | 0.5%      | H43A    | SOT23-5L  |                          |
| TLVH431BIL5T | 0.25%     | H43B    |           |                          |
| TLVH431LIL5T | 1.5%      | 43L     |           |                          |
| TLVH431AICT  | 0.5%      | H43     | SOT323-6L |                          |
| TLVH431BICT  | 0.25%     | H43     |           |                          |
| TLVH431LICT  | 1.5%      | 43L     |           |                          |

---

# Contents

|          |  |           |
|----------|--|-----------|
| <b>1</b> | <b>Pin configuration</b> .....                   | <b>3</b>  |
| <b>2</b> | <b>Maximum ratings</b> .....                     | <b>4</b>  |
| <b>3</b> | <b>Electrical characteristics</b> .....          | <b>5</b>  |
| <b>4</b> | <b>Typical performance characteristics</b> ..... | <b>6</b>  |
| <b>5</b> | <b>Package information</b> .....                 | <b>8</b>  |
| 5.1      | SOT23-3L package information .....               | 8         |
| 5.2      | SOT23-5L package information .....               | 10        |
| 5.3      | SOT323-6L package information .....              | 12        |
| <b>6</b> | <b>Revision History</b> .....                    | <b>14</b> |

# 1 Pin configuration

Figure 1. Pin configuration (top view)

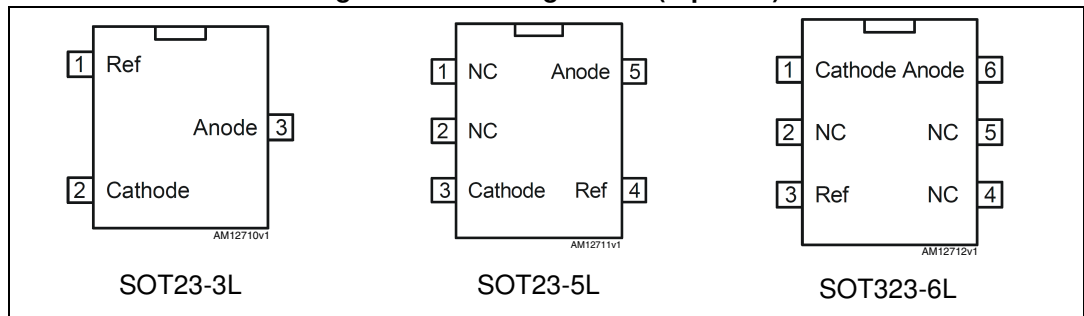

## 2 Maximum ratings

**Table 2. Absolute maximum ratings**

| Symbol     | Parameter                           | Value         | Unit |
|------------|-------------------------------------|---------------|------|
| $V_{KA}$   | Cathode to anode voltage            | 22            | V    |
| $I_K$      | Continuous cathode current range    | - 100 to +100 | mA   |
| $I_{REF}$  | Reference input current range       | - 0.05 to +3  | mA   |
| $T_{STG}$  | Storage temperature                 | - 65 to +150  | °C   |
| ESD        | Human body model (HBM)              | 2             | kV   |
|            | Machine model (MM)                  | 200           | V    |
|            | Charged device model                | 1500          | V    |
| $T_{LEAD}$ | Lead temperature (soldering) 10 sec | 260           | °C   |
| $T_J$      | Max. junction temperature           | +150          | °C   |

*Note:* Absolute maximum ratings are those values beyond which damage to the device may occur. Functional operation under these conditions is not implied.

**Table 3. Thermal data**

| Symbol     | Parameter                           | SOT323-6L | SOT23-3L | SOT23-5L | Unit |
|------------|-------------------------------------|-----------|----------|----------|------|
| $R_{thJA}$ | Thermal resistance junction-ambient | 221       | 248      | 157      | °C/W |
| $R_{thJC}$ | Thermal resistance junction-case    | 110       | 136      | 67       | °C/W |

**Table 4. Operating conditions**

| Symbol     | Parameter                            | Value           | Unit |
|------------|--------------------------------------|-----------------|------|
| $V_{KA}$   | Cathode to anode voltage             | $V_{ref}$ to 18 | V    |
| $I_{kmin}$ | Minimum operating current            | 100             | μA   |
| $I_{kmax}$ | Maximum operating current            | 60              | mA   |
| $T_{oper}$ | Operating free air temperature range | -40 to +125     | °C   |

### 3 Electrical characteristics

$I_k = 10 \text{ mA}$ ,  $T_{\text{amb}} = 25 \text{ }^\circ\text{C}$  (unless otherwise specified).

**Table 5. Electrical characteristics for TLVH431**

| Symbol   | Parameter  | Test conditions   | Min.                             | Typ.     | Max.                             | Unit                  |
|--|--|---|----------------------------------|----------|----------------------------------|-----------------------|
| $V_{\text{ref}}$                                     | Reference voltage  | $V_{\text{KA}} = V_{\text{ref}}$<br>TLVH431A 0.5%<br>TLVH431B 0.25%<br>TLVH431M 1%<br>TLVH431L 1.5%   | 1.234<br>1.237<br>1.227<br>1.222 | 1.24     | 1.246<br>1.243<br>1.253<br>1.258 | V                     |
| $\Delta V_{\text{ref}}$                              | Reference voltage variation over temperature range <sup>(1)</sup>                | $-40 \text{ }^\circ\text{C} < T_{\text{amb}} < +125 \text{ }^\circ\text{C}$<br>TLVH431A 0.5%<br>TLVH431B 0.25%<br>TLVH431M 1%<br>TLVH431L 1.5%    | -26.7<br>-23.5<br>-32.8<br>-39   |          | +26.7<br>+23.5<br>+32.8<br>+39   | mV                    |
| $\Delta V_{\text{KA}}/\Delta T$                      | Average temperature coefficient  | $V_{\text{KA}} = V_{\text{ref}}$ , $-40 \text{ }^\circ\text{C} < T_{\text{amb}} < +125 \text{ }^\circ\text{C}$                                    |                                  | $\pm 30$ | $\pm 100$                        | ppm/ $^\circ\text{C}$ |
| $I_{\text{kmin}}$                                    | Minimum cathode current for regulation   | $V_{\text{KA}} = V_{\text{ref}}$  |                                  | 60       | 100                              | $\mu\text{A}$         |
|  |  | $V_{\text{KA}} = V_{\text{KAmax}}$  |                                  | 160      | 200                              |                       |
| $\Delta I_{\text{kmin}}$                             | Minimum cathode current variation over temperature range                         | $V_{\text{KA}} = V_{\text{ref}}$ , $-40 \text{ }^\circ\text{C} < T_{\text{amb}} < +125 \text{ }^\circ\text{C}$                                    |                                  | 70       | 100                              | $\mu\text{A}$         |
|  |  | $V_{\text{KA}} = V_{\text{KAmax}}$ , $-40 \text{ }^\circ\text{C} < T_{\text{amb}} < +125 \text{ }^\circ\text{C}$                                  |                                  | 100      | 200                              |                       |
| $I_{\text{ref}}$                                     | Reference input current  | $R_1 = 10 \text{ k}\Omega$ , $R_2 = \infty$   |                                  | 1.5      | 2.5                              | $\mu\text{A}$         |
| $\Delta I_{\text{ref}}$                              | Reference current variation over temperature range                               | $R_1 = 10 \text{ k}\Omega$ , $R_2 = \infty$<br>$-40 \text{ }^\circ\text{C} < T_{\text{amb}} < +125 \text{ }^\circ\text{C}$                        |                                  | 2.5      | 3.5                              | $\mu\text{A}$         |
| $\frac{\Delta V_{\text{ref}}}{\Delta V_{\text{ka}}}$ | Ratio of change in reference input voltage to change in cathode to anode voltage | $\Delta V_{\text{KA}} = 18 \text{ V to } V_{\text{ref}}$  |                                  |          | -2                               | mV/V                  |
|  |  | $\Delta V_{\text{KA}} = 18 \text{ V to } V_{\text{ref}}$ , $-40 \text{ }^\circ\text{C} < T_{\text{amb}} < +125 \text{ }^\circ\text{C}$            |                                  |          | -2.5                             |                       |
| $I_{\text{off}}$                                     | Off-state cathode current  | $V_{\text{KA}} = V_{\text{KAmax}}$ , $V_{\text{ref}} = \text{GND}$  |                                  | 10       | 80                               | nA                    |
| $\Delta I_{\text{off}}$                              | Off-state cathode current over temperature range                                 | $V_{\text{KA}} = V_{\text{KAmax}}$ , $V_{\text{ref}} = \text{GND}$<br>$-40 \text{ }^\circ\text{C} < T_{\text{amb}} < +125 \text{ }^\circ\text{C}$ |                                  | 1000     | 2000                             | nA                    |
| $ R_{\text{KA}} $                                    | Static impedance   | $V_{\text{KA}} = V_{\text{ref}}$ , $\Delta I_{\text{K}} = 100 \text{ } \mu\text{A to } 60 \text{ mA}$   |                                  | 0.14     | 0.62                             | W                     |
| $ Z_{\text{KA}} $                                    | Dynamic impedance <sup>(2)</sup>   | $V_{\text{KA}} = V_{\text{ref}}$ , $\Delta I_{\text{K}} = 10 \text{ mA to } 60 \text{ mA}$ , $f \leq 1 \text{ kHz}$                               |                                  | 0.22     | 0.85                             | W                     |
| $e_n$  | Wide band noise  | $I_{\text{K}} = 10 \text{ mA}$ ; $10 \text{ Hz} < f < 100 \text{ kHz}$  |                                  | 30       |                                  | mV <sub>RMS</sub>     |
| $T_{\text{ON}}$                                      | Turn-on setting time   | $V_{\text{KA}} = V_{\text{ref}}$ , $\Delta I_{\text{K}} = 10 \text{ mA}$  |                                  | 40       | 70                               | $\mu\text{sec}$       |

1. The tolerance values, across the temperature range, are calculated as:  $\pm V_{\text{k}25^\circ\text{C}} \times \{\text{tolerance}_{25^\circ\text{C}} + [(\text{ppm}_{\text{max}}/^\circ\text{C}) \times (\Delta T)]\}$ .

Example: TLVH431A  $\Delta V_{\text{k}} = \pm 1.24 \times (0.5\% + 100 \text{ ppm}/^\circ\text{C} \times 165 \text{ }^\circ\text{C}) = \pm 1.24 \times (0.5\% + 1.65\%) = \pm 1.24 \times 2.15\% = \pm 26.7 \text{ mV}$ .

2. The dynamic impedance is defined as  $|Z_{\text{KA}}| = \Delta V_{\text{KA}}/\Delta I_{\text{k}}$ .

**Note:** Limits are 100% production tested at 25 °C. Limits over the temperature range are guaranteed through correlation and by design.

# 4 Typical performance characteristics

The following plots are referred to the typical application circuit and, unless otherwise noted, at  $T_A = 25\text{ }^\circ\text{C}$ .

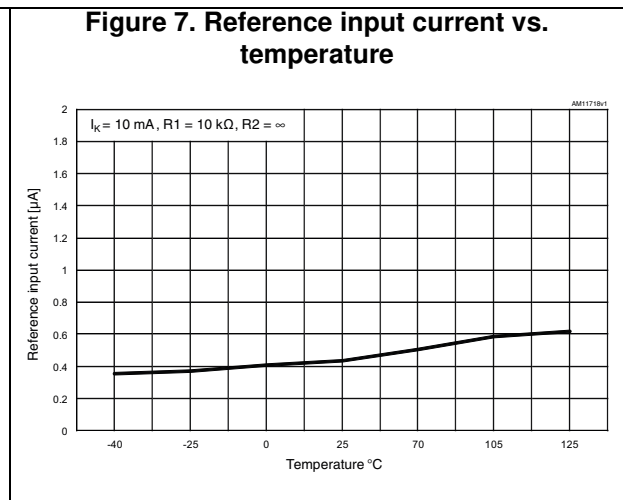
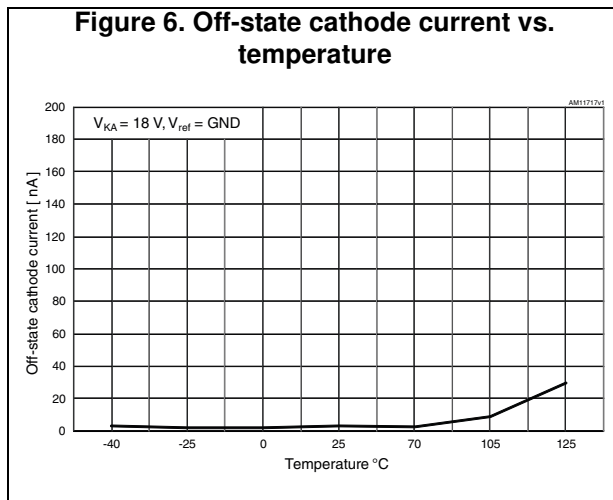
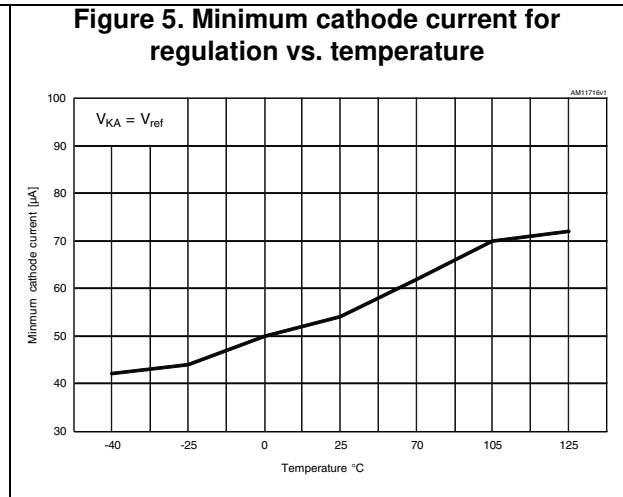
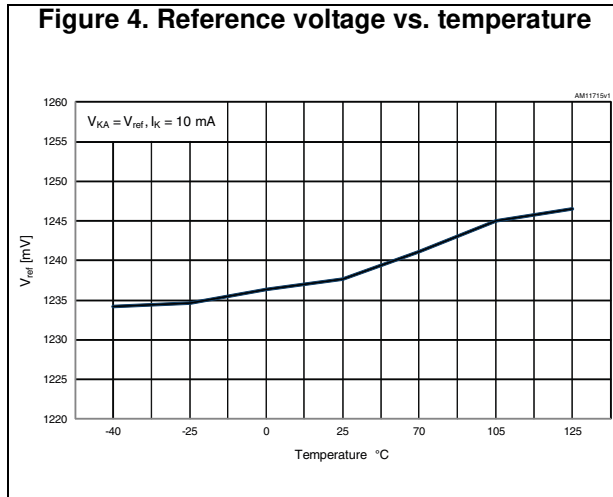
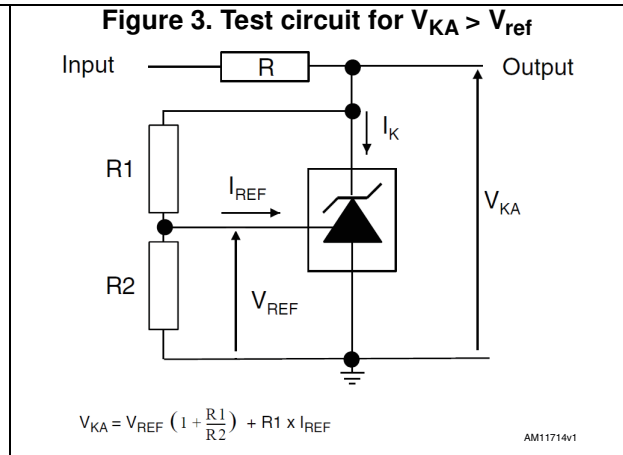
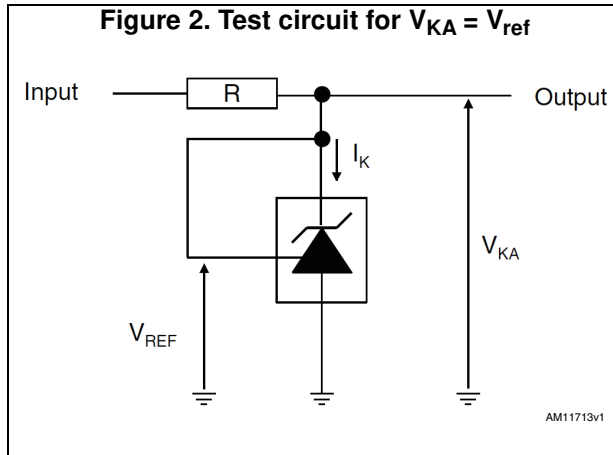

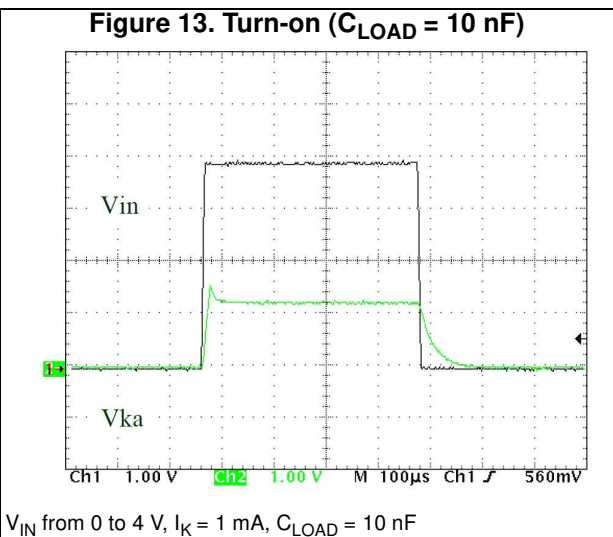
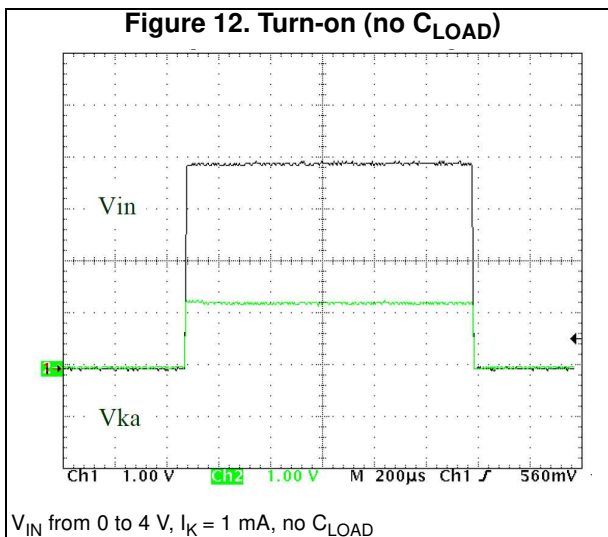
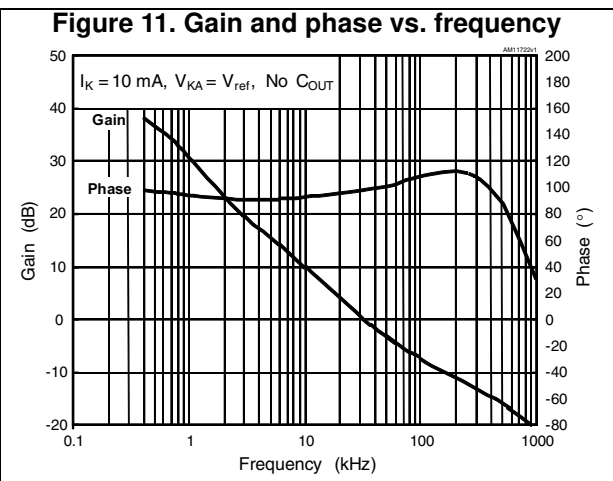
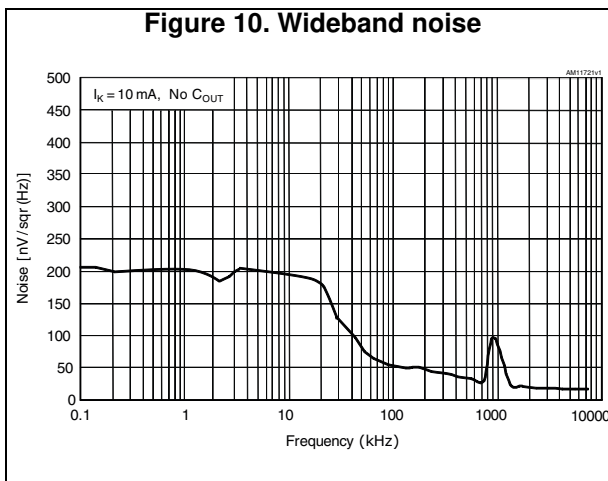
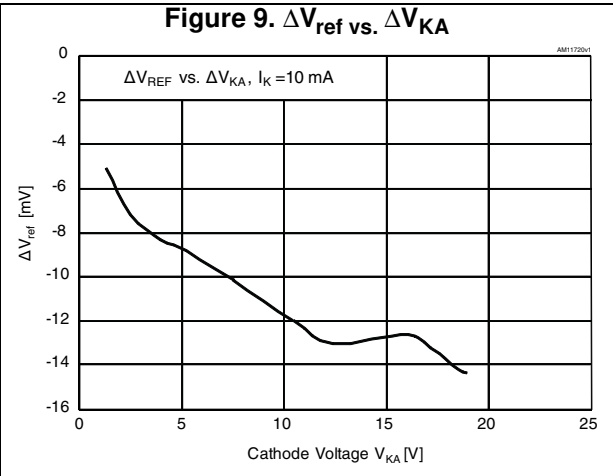
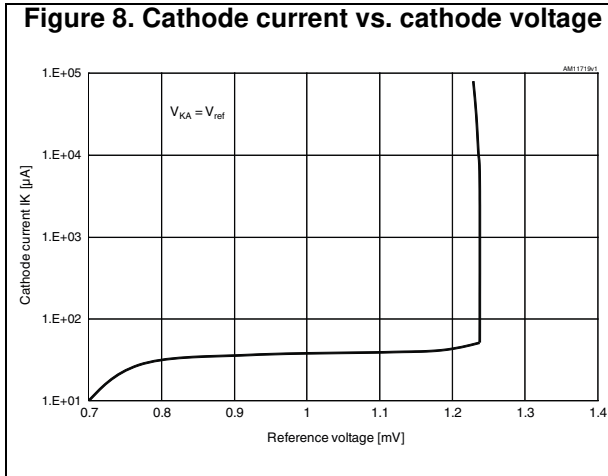

## 5 Package information

In order to meet environmental requirements, ST offers these devices in different grades of ECOPACK packages, depending on their level of environmental compliance. ECOPACK specifications, grade definitions and product status are available at: [www.st.com](http://www.st.com). ECOPACK is an ST trademark.

### 5.1 SOT23-3L package information

Figure 14. SOT23-3L package outline

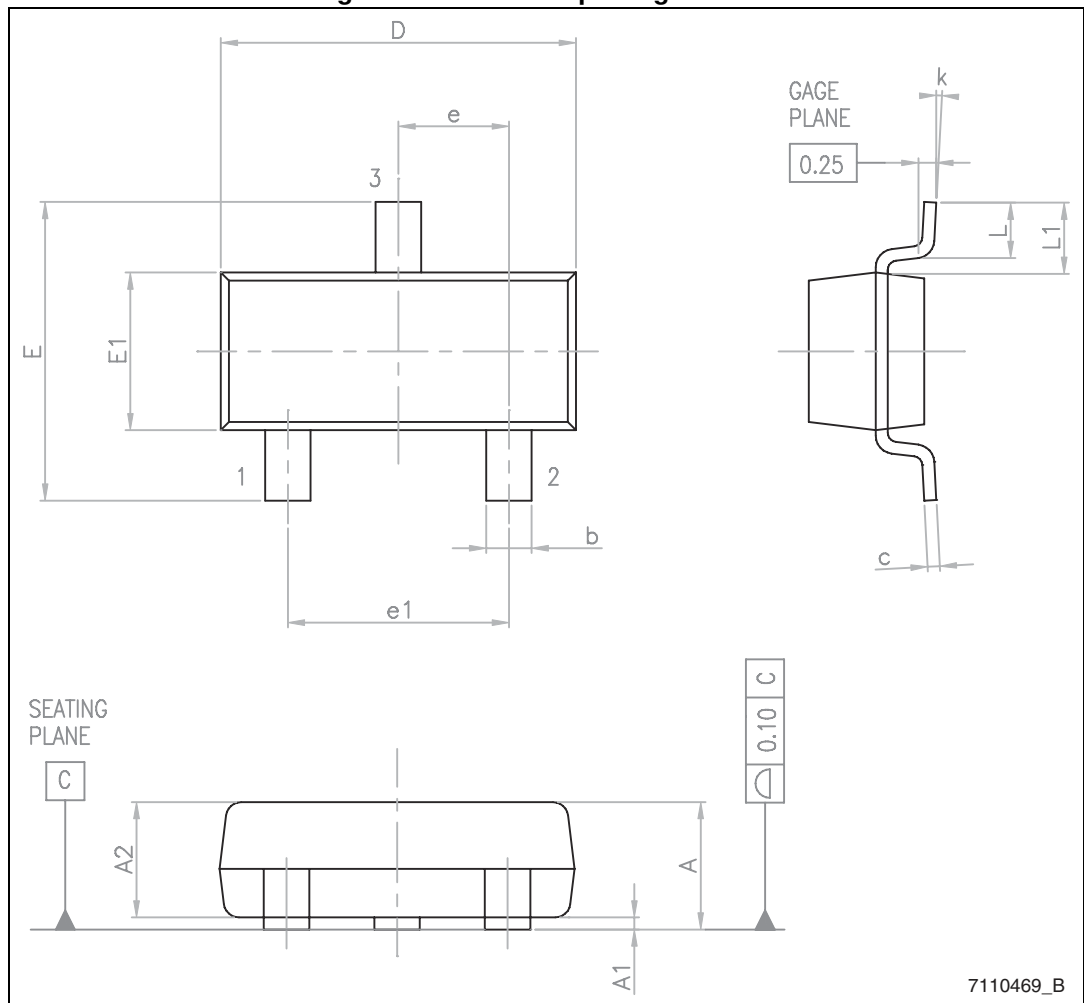



Table 6. SOT23-3L mechanical data

| Dim. | mm   |      |      |
|------|------|------|------|
|      | Min. | Typ. | Max. |
| A    | 0.89 |      | 1.12 |
| A1   | 0.01 |      | 0.10 |
| A2   | 0.88 | 0.95 | 1.02 |
| b    | 0.30 |      | 0.50 |
| c    | 0.08 |      | 0.20 |
| D    | 2.80 | 2.90 | 3.04 |
| E    | 2.10 |      | 2.64 |
| E1   | 1.20 | 1.30 | 1.40 |
| e    |      | 0.95 |      |
| e1   |      | 1.90 |      |
| L    | 0.40 | 0.50 | 0.60 |
| L1   |      | 0.54 |      |
| k    | 0°   |      | 8°   |

## 5.2 SOT23-5L package information

Figure 15. SOT23-5L package outline

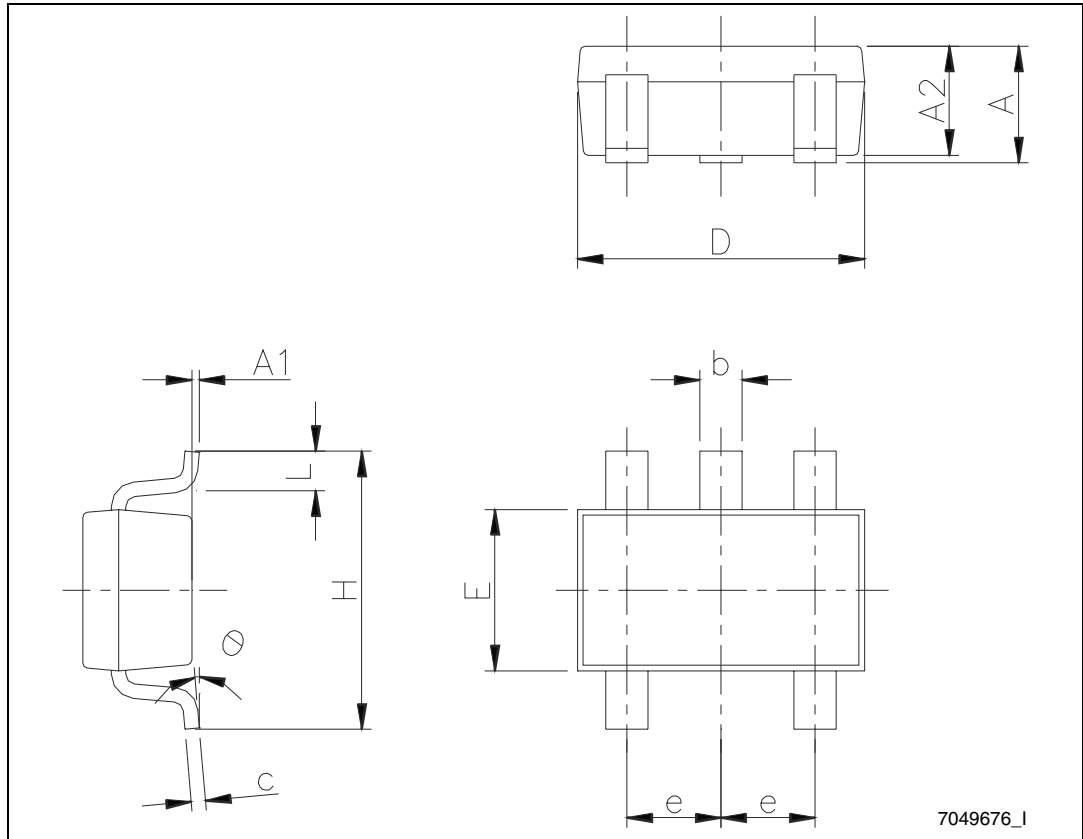
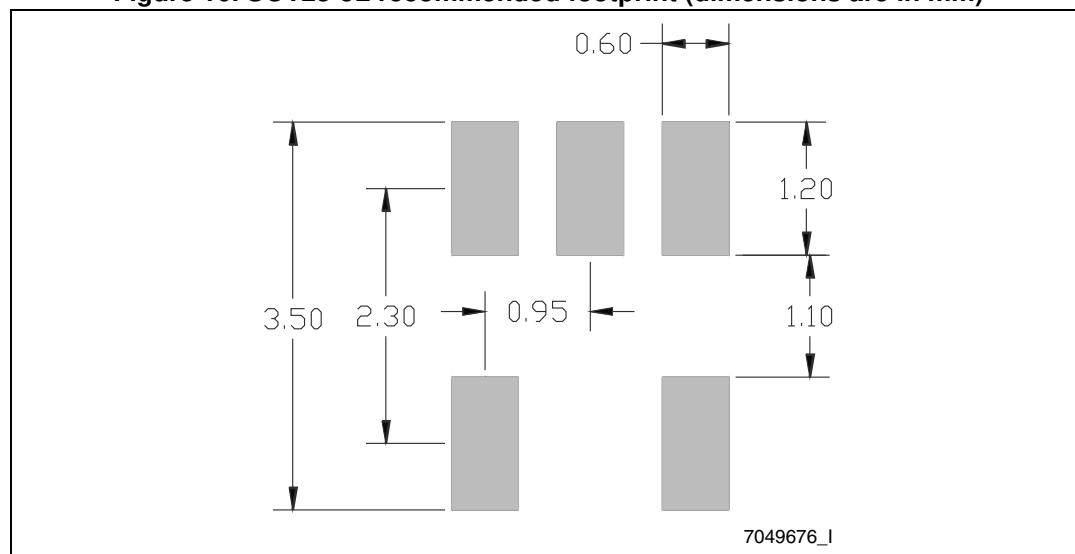

Table 7. SOT23-5L mechanical data

| Dim.     | mm   |      |      |
|----------|------|------|------|
|          | Min. | Typ. | Max. |
| A        | 0.90 | 1.20 | 1.45 |
| A1       |      |      | 0.15 |
| A2       | 0.90 | 1.05 | 1.30 |
| b        | 0.35 | 0.40 | 0.50 |
| c        | 0.09 | 0.15 | 0.20 |
| D        | 2.80 | 2.90 | 3.00 |
| e        |      | 0.95 |      |
| E        | 1.50 | 1.60 | 1.75 |
| H        | 2.60 | 2.80 | 3.00 |
| L        | 0.10 | 0.35 | 0.60 |
| $\theta$ | 0°   |      | 10°  |

Figure 16. SOT23-5L recommended footprint (dimensions are in mm)



### 5.3 SOT323-6L package information

Figure 17. SOT323-6L package outline

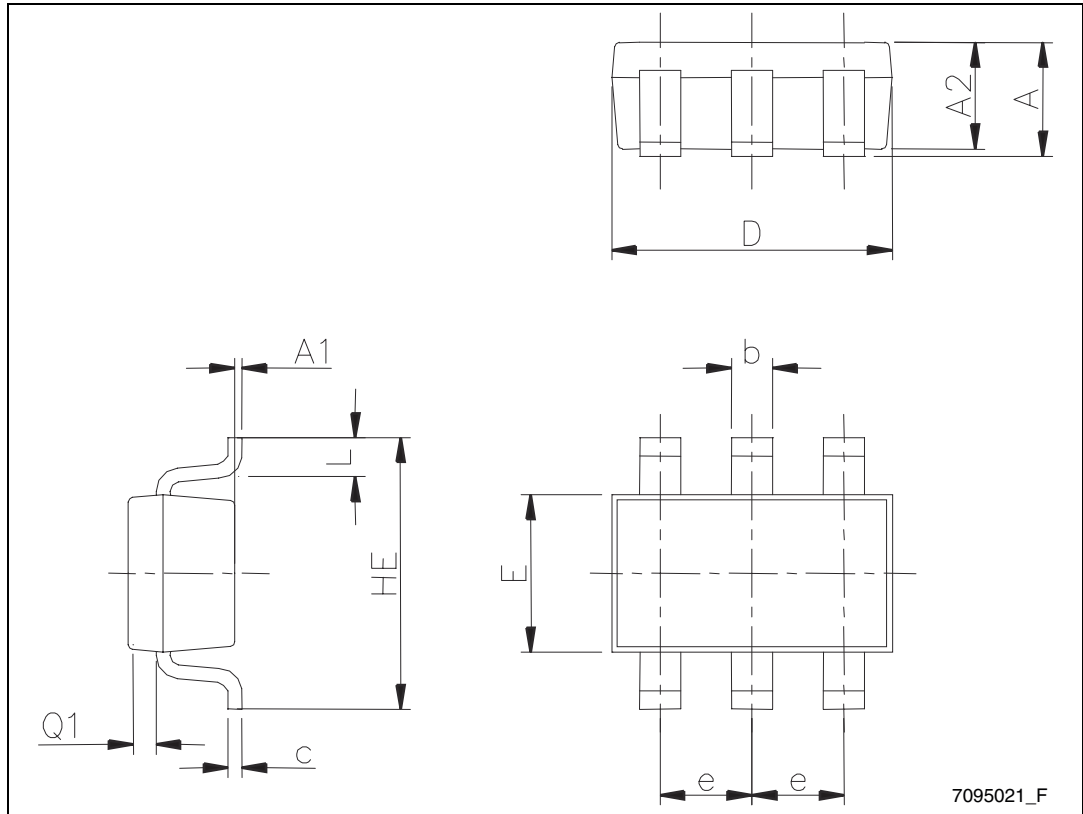
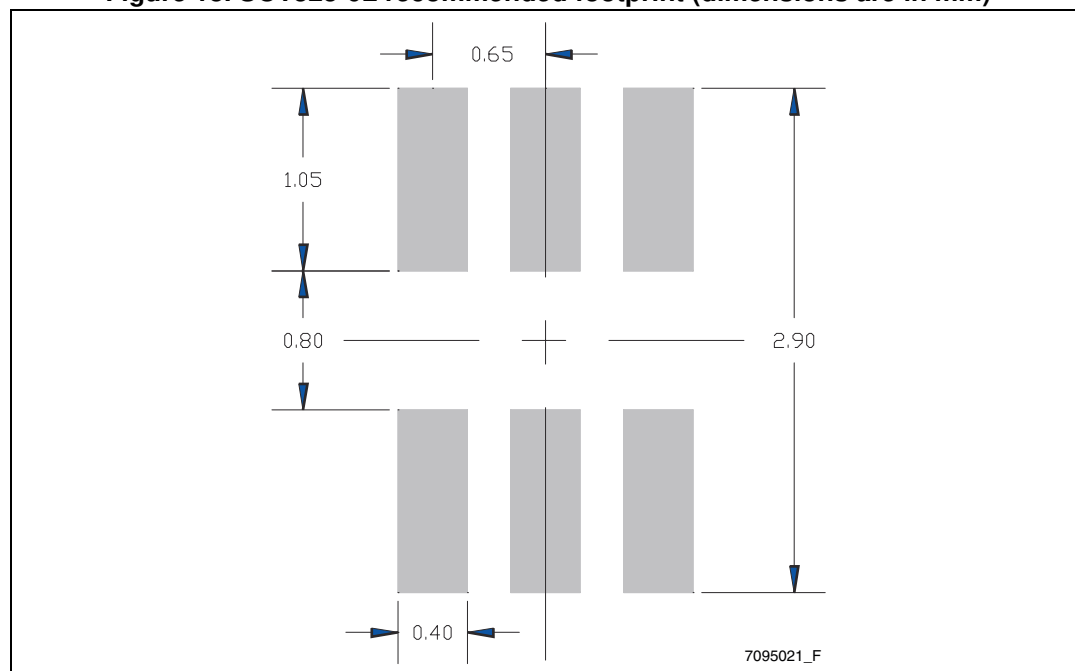

Table 8. SOT323-6L mechanical data

| Dim. | mm   |      |      |
|------|------|------|------|
|      | Min. | Typ. | Max. |
| A    | 0.80 |      | 1.10 |
| A1   | 0    |      | 0.10 |
| A2   | 0.80 |      | 1.00 |
| b    | 0.15 |      | 0.30 |
| c    | 0.10 |      | 0.18 |
| D    | 1.80 |      | 2.20 |
| E    | 1.15 |      | 1.35 |
| e    |      | 0.65 |      |
| HE   | 1.80 |      | 2.40 |
| L    | 0.10 |      | 0.40 |
| Q1   | 0.10 |      | 0.40 |

Figure 18. SOT323-6L recommended footprint (dimensions are in mm)



## 6 Revision History

**Table 9. Document revision history**

| Date        | Revision | Changes   |
|-------------|----------|---|
| 13-Jun-2012 | 1        | Initial release.  |
| 23-Jan-2014 | 2        | Updated the Features in cover page, Table 1: Device summary and Table 5: Electrical characteristics for TLVH431.<br>Minor text changes. |
| 28-Jan-2014 | 3        | Updated the min. value of Vref in Table 5: Electrical characteristics for TLVH431.  |
| 24-Mar-2015 | 4        | Updated Table 7: SOT23-5L mechanical data.<br>Minor text changes.   |
| 23-Nov-2015 | 5        | Updated features in cover page, Table 1: Device summary and Table 5: Electrical characteristics for TLVH431.<br>Minor text changes.     |
| 05-Dec-2017 | 6        | Updated title on the cover page.  |
| 07-Jul-2020 | 7        | Updated footnote in <a href="#">Table 5</a> .   |
| 18-Sep-2020 | 8        | Added Marking in <a href="#">Table 1: Device summary</a> on the cover page.   |

**IMPORTANT NOTICE – PLEASE READ CAREFULLY**

STMicroelectronics NV and its subsidiaries (“ST”) reserve the right to make changes, corrections, enhancements, modifications, and improvements to ST products and/or to this document at any time without notice. Purchasers should obtain the latest relevant information on ST products before placing orders. ST products are sold pursuant to ST’s terms and conditions of sale in place at the time of order acknowledgement.

Purchasers are solely responsible for the choice, selection, and use of ST products and ST assumes no liability for application assistance or the design of Purchasers’ products.

No license, express or implied, to any intellectual property right is granted by ST herein.

Resale of ST products with provisions different from the information set forth herein shall void any warranty granted by ST for such product.

ST and the ST logo are trademarks of ST. For additional information about ST trademarks, please refer to [www.st.com/trademarks](http://www.st.com/trademarks). All other product or service names are the property of their respective owners.

Information in this document supersedes and replaces information previously supplied in any prior versions of this document.

© 2020 STMicroelectronics – All rights reserved

## X-ON Electronics

Largest Supplier of Electrical and Electronic Components

*Click to view similar products for [Voltage References](#) category:*

*Click to view products by [STMicroelectronics](#) manufacturer:*

Other Similar products are found below :

[REF01J/883](#) [5962-8686103XC](#) [NCV431BVDMR2G](#) [LT6654AMPS6-2.048#TRMPBF](#) [SCV431AIDMR2G](#) [LT1019AIS8-2.5](#) [SC431ILPRAG](#)  
[AP432AQG-7](#) [NJM2823F-TE1](#) [TL431-A](#) [MCP1502T-18E/CHY](#) [MCP1502T-40E/CHY](#) [TL431ACZ](#) [KA431SLMF2TF](#) [KA431SMF2TF](#)  
[KA431SMFTF](#) [LM4040QCEM3-3.0/NOPB](#) [LM4041C12ILPR](#) [LM4120AIM5-2.5/NOP](#) [LM431SCCMFX](#) [TS3330AQPR](#) [REF5040MDREP](#)  
[REF3012AIDBZR](#) [LM285BXM3-1.2/NOPB](#) [LM385BM-2.5/NOPB](#) [LM4040AIM3-10.0](#) [LM4040BIM3-4.1](#) [LM4040CIM3-10.0](#)  
[LM4040CIM3X-2.0/NOPB](#) [LM4041BSD-122GT3](#) [LM4041QDIM3-ADJ/NO](#) [LM4050QAEM3X4.1/NOPB](#) [LM4051BIM3-ADJ/NOPB](#)  
[LM4051CIM3X-1.2/NOPB](#) [LM4128CMF-1.8/NOPB](#) [LM4132DMF-1.8/NOPB](#) [LM4132EMF-1.8/NOPB](#) [LM4132EMF-2.0/NOPB](#)  
[LM4140CCMX-1.2/NOPB](#) [LM431CIM](#) [LM385BD-2.5R2G](#) [LM385M-2.5/NOPB](#) [LM4030AMF-4.096/NOPB](#) [LM4040D30ILPR](#)  
[LM4051CIM3X-ADJ/NOPB](#) [AP432YG-13](#) [AS431ANTR-G1](#) [AS431BZTR-E1](#) [AN431AN-ATRG1](#) [AP431IBNTR-G1](#)