

Micropower high precision series voltage reference

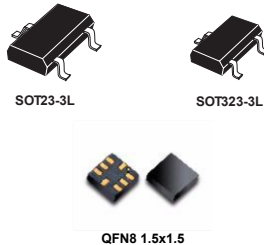

Features

- Fixed 1.25 V, 1.8 V, 2.048 V, 2.5 V, 3.0 V, 3.3 V, 4.096 V, 5.0 V output voltage
- Ultra low operating current: 3.9 μ A (typ.) at 25 °C
- High initial accuracy: +/-0.15 %
- Stable when used with capacitive loads
- Extended temperature range: -40 to +125 °C
- 30 ppm/°C maximum temperature coefficient
- Available in QFN8 1.5x1.5, SOT23-3L and SOT323-3L packages.

Applications

- Portable equipment
- Data acquisition systems
- Instrumentation
- Medical equipment
- Test equipment

Description

The **TS33** family of low power series voltage references is capable of providing stable and precise output voltages with an initial accuracy of 0.15% over an extended temperature range (-40 to +125 °C).

The ultra low operating current is a key advantage for power-restricted designs. In addition, the **TS33** is very stable over the entire operating temperature range, making it suitable for high-precision applications.

Available in QFN8, SOT23-3L and SOT323-3L surface mount packages, the **TS33** can be designed in applications where space saving is a critical issue.

Maturity status link

[TS33](#)

1 Pin configuration

Figure 1. Pin configuration (top view)

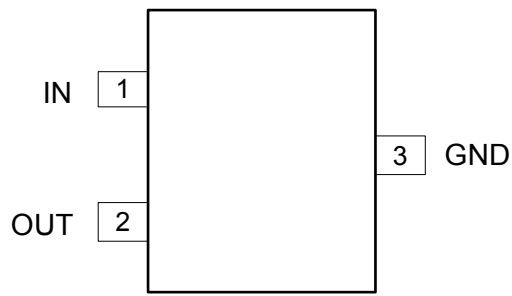

SOT23-3L/SOT323-3L

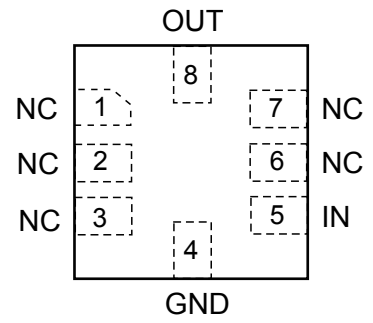

QFN8

2 Maximum ratings

Table 1. Absolute maximum ratings

Symbol	Parameter	Value	Unit
V_{IN}	Maximum input voltage	-0.3 to 7	V
V_{OUT}	Maximum voltage on the output pin	-0.3 to $V_{IN} + 0.3$	V
I_{OUT}	Output short-circuit current (sinking/sourcing)	Internally limited	mA
P_d	Power dissipation ⁽¹⁾	700	mW
T_{stg}	Storage temperature	-65 to +150	°C
ESD	Human body model (HBM)	4	kV
	Charged device model	1000	V
T_{lead}	Lead temperature (soldering) 10 s	260	°C
T_j	Max junction temperature	+150	°C

1. P_d has been calculated with $T_{amb} = 25\text{ °C}$ and $T_{jmax} = 150\text{ °C}$

Note: Absolute maximum ratings are those values beyond which damage to the device may occur. Functional operation under these conditions is not implied.

Table 2. Thermal data

Symbol	Parameter	QFN8	SOT23-3L	SOT323-3L	Unit
R_{thJA}	Thermal resistance junction-ambient	159	246	242	°C/W
R_{thJC}	Thermal resistance junction-case	103	171	103	°C/W

Table 3. Recommended operating conditions

Symbol	Parameter	Value	Unit
V_{IN}	Operating input voltage range	1.8 to 5.5	V
I_{OUT}	Maximum operating current	± 5	mA
T_{oper}	Operating free air temperature range	-40 to +125	°C

3 Typical application

Figure 2. Typical application circuit

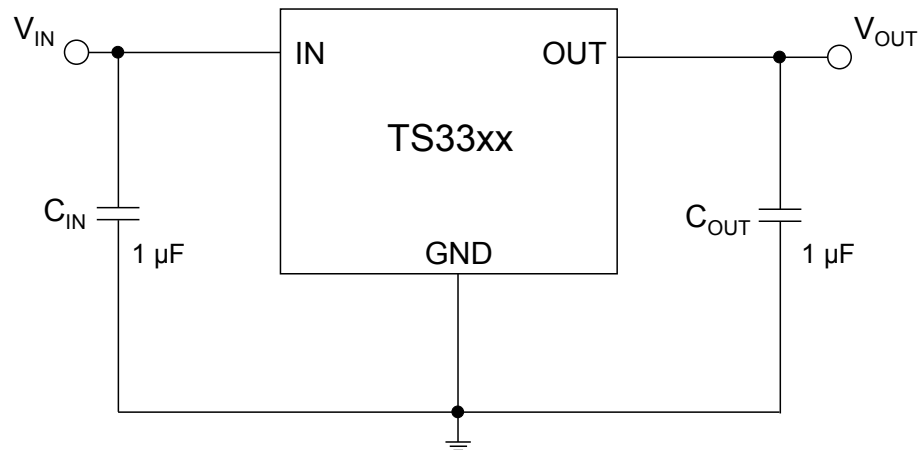

4 Electrical characteristics

$V_{IN} = 5\text{ V}$, $I_{LOAD} = 0\text{ mA}$, $T_{amb} = 25\text{ °C}$ (unless otherwise specified).

Table 4. Electrical characteristics for TS3312

Symbol	Parameter	Test condition	Min.	Typ.	Max.	Unit
V_{IN}	Minimum input voltage	$I_{LOAD} = 0\text{ mA}$ $T_{amb} = 25\text{ °C}$	1.8			V
V_{OUT}	Output voltage	$V_{IN} = 5\text{ V}$		1.25		V
	Initial accuracy	$I_{LOAD} = 0\text{ mA}$ $T_{amb} = 25\text{ °C}$	-0.15		0.15	%
$\Delta V_{OUT}/\Delta T$	Average temperature coefficient	$-40\text{ °C} < T_{amb} < +85\text{ °C}$		9	30	ppm/°C
		$-40\text{ °C} < T_{amb} < +125\text{ °C}$		8	30	
$\Delta V_{OUT}/\Delta V_{IN}$	Line regulation	$V_{IN} = 1.8\text{ V to } 5.5\text{ V}$	-50	6	+50	ppm/V
		$0\text{ °C} < T_{amb} < 70\text{ °C}$		6		
		$-40\text{ °C} < T_{amb} < +85\text{ °C}$		8		
		$-40\text{ °C} < T_{amb} < +125\text{ °C}$		30		
$\Delta V_{OUT}/\Delta I_{LOAD}$	Load regulation	$V_{IN} = 1.8\text{ V}$	-50	6	+50	ppm/mA
		$I_{LOAD} = \pm 5\text{ mA}$ $0\text{ °C} < T_{amb} < 70\text{ °C}$		10		
		$-40\text{ °C} < T_{amb} < +85\text{ °C}$		20		
		$-40\text{ °C} < T_{amb} < +125\text{ °C}$		20		
I_{SC}	Short-circuit current sourcing/sinking			35		mA
I_Q	Quiescent current			3.9	7	μA
		$-40\text{ °C} < T_{amb} < +85\text{ °C}$		4.4	7.5	
		$-40\text{ °C} < T_{amb} < +125\text{ °C}$		4.8	10	
C_{OUT}	Capacitive load		0.1		10	μF
T_{ON}	Turn-on settling time	to 0.1 %, $C_{OUT} = 1\text{ }\mu\text{F}$		2		ms
e_n	Noise floor	$f = 0.1\text{ Hz to } 10\text{ Hz}$		27		μV_{P-P}

Table 5. Electrical characteristics for TS3320

Symbol	Parameter	Test conditions	Min.	Typ.	Max.	Unit
V_{OUT}	Output voltage	$V_{IN} = 5\text{ V}$		2.048		V
	Initial accuracy	$I_{LOAD} = 0\text{ mA}$ $T_{amb} = 25\text{ °C}$	-0.15		0.15	%
$\Delta V_{OUT}/\Delta T$	Average temperature coefficient	$-40\text{ °C} < T_{amb} < +85\text{ °C}$		9	30	ppm/°C
		$-40\text{ °C} < T_{amb} < +125\text{ °C}$		8	30	
$\Delta V_{OUT}/\Delta V_{IN}$	Line regulation	$V_{IN} = 2.7\text{ V to } 5.5\text{ V}$	-50	6	+50	ppm/V
		$0\text{ °C} < T_{amb} < 70\text{ °C}$		6		
		$-40\text{ °C} < T_{amb} < +85\text{ °C}$		8		
		$-40\text{ °C} < T_{amb} < +125\text{ °C}$		30		
$\Delta V_{OUT}/\Delta I_{LOAD}$	Load regulation	$V_{IN} = 2.7\text{ V}$	-50	6	+50	ppm/mA
		$I_{LOAD} = \pm 5\text{ mA}$ $0\text{ °C} < T_{amb} < 70\text{ °C}$		10		
		$-40\text{ °C} < T_{amb} < +85\text{ °C}$		20		
		$-40\text{ °C} < T_{amb} < +125\text{ °C}$		20		
V_{DROP}	Minimum dropout voltage	$I_{LOAD} = \pm 5\text{ mA}$		100	160	mV
		$0\text{ °C} < T_{amb} < 70\text{ °C}$		70		
		$-40\text{ °C} < T_{amb} < +85\text{ °C}$		75		
		$-40\text{ °C} < T_{amb} < +125\text{ °C}$		80		
		$I_{LOAD} = \pm 2\text{ mA}$ $-40\text{ °C} < T_{amb} < +85\text{ °C}$			80	
I_{SC}	Short-circuit current sourcing/sinking			35		mA
I_Q	Quiescent current			3.9	7	μA
		$-40\text{ °C} < T_{amb} < +85\text{ °C}$		4.4	7.5	
		$-40\text{ °C} < T_{amb} < +125\text{ °C}$		4.8	10	
C_{OUT}	Capacitive load		0.1		10	μF
T_{ON}	Turn-on settling time	to 0.1 %, $C_{OUT} = 1\text{ }\mu\text{F}$		2		ms
e_n	Noise floor	$f = 0.1\text{ Hz to } 10\text{ Hz}$		47		μV_{P-P}

Table 6. Electrical characteristics for TS3325

Symbol	Parameter	Test conditions	Min.	Typ.	Max.	Unit
V_{OUT}	Output voltage	$V_{IN} = 5\text{ V}$		2.5		V
	Initial accuracy	$I_{LOAD} = 0\text{ mA}$ $T_{amb} = 25\text{ °C}$	-0.15		0.15	%
$\Delta V_{OUT}/\Delta T$	Average temperature coefficient	$-40\text{ °C} < T_{amb} < +85\text{ °C}$		9	30	ppm/°C
		$-40\text{ °C} < T_{amb} < +125\text{ °C}$		8	30	
$\Delta V_{OUT}/\Delta V_{IN}$	Line regulation	$V_{IN} = 2.7\text{ V to } 5.5\text{ V}$	-50	6	+50	ppm/V
		$0\text{ °C} < T_{amb} < 70\text{ °C}$		6		
		$-40\text{ °C} < T_{amb} < +85\text{ °C}$		8		
		$-40\text{ °C} < T_{amb} < +125\text{ °C}$		30		
$\Delta V_{OUT}/\Delta I_{LOAD}$	Load regulation	$V_{IN} = 2.7\text{ V}$	-50	6	+50	ppm/mA
		$I_{LOAD} = \pm 5\text{ mA}$ $0\text{ °C} < T_{amb} < 70\text{ °C}$		10		
		$-40\text{ °C} < T_{amb} < +85\text{ °C}$		20		
		$-40\text{ °C} < T_{amb} < +125\text{ °C}$		20		
V_{DROP}	Minimum dropout voltage	$I_{LOAD} = \pm 5\text{ mA}$		50	100	mV
		$0\text{ °C} < T_{amb} < 70\text{ °C}$		70		
		$-40\text{ °C} < T_{amb} < +85\text{ °C}$		75		
		$-40\text{ °C} < T_{amb} < +125\text{ °C}$		80		
		$I_{LOAD} = \pm 2\text{ mA}$ $-40\text{ °C} < T_{amb} < +85\text{ °C}$			70	
I_{SC}	Short-circuit current sourcing/sinking			35		mA
I_Q	Quiescent current			3.9	7	μA
		$-40\text{ °C} < T_{amb} < +85\text{ °C}$		4.4	7.5	
		$-40\text{ °C} < T_{amb} < +125\text{ °C}$		4.8	10	
C_{OUT}	Capacitive load		0.1		10	μF
T_{ON}	Turn-on settling time	to 0.1 %, $C_{OUT} = 1\text{ }\mu\text{F}$		2		ms
e_n	Noise floor	$f = 0.1\text{ Hz to } 10\text{ Hz}$		57		$\mu\text{V}_{P.P}$

Table 7. Electrical characteristics for TS3330

Symbol	Parameter	Test conditions	Min.	Typ.	Max.	Unit
V_{OUT}	Output voltage	$V_{IN} = 5\text{ V}$		3.0		V
	Initial accuracy	$I_{LOAD} = 0\text{ mA}$ $T_{amb} = 25\text{ °C}$	-0.15		0.15	%
$\Delta V_{OUT}/\Delta T$	Average temperature coefficient	$-40\text{ °C} < T_{amb} < +85\text{ °C}$		9	30	ppm/°C
		$-40\text{ °C} < T_{amb} < +125\text{ °C}$		8	30	
$\Delta V_{OUT}/\Delta V_{IN}$	Line regulation	$V_{IN} = 3.2\text{ V to } 5.5\text{ V}$	-50	6	+50	ppm/V
		$0\text{ °C} < T_{amb} < 70\text{ °C}$		6		
		$-40\text{ °C} < T_{amb} < +85\text{ °C}$		8		
		$-40\text{ °C} < T_{amb} < +125\text{ °C}$		30		
$\Delta V_{OUT}/\Delta I_{LOAD}$	Load regulation	$V_{IN} = 3.2\text{ V}$	-50	6	+50	ppm/mA
		$I_{LOAD} = \pm 5\text{ mA}$ $0\text{ °C} < T_{amb} < 70\text{ °C}$		10		
		$-40\text{ °C} < T_{amb} < +85\text{ °C}$		20		
		$-40\text{ °C} < T_{amb} < +125\text{ °C}$		20		
V_{DROP}	Minimum dropout voltage	$I_{LOAD} = \pm 5\text{ mA}$		50	100	mV
		$0\text{ °C} < T_{amb} < 70\text{ °C}$		70		
		$-40\text{ °C} < T_{amb} < +85\text{ °C}$		75		
		$-40\text{ °C} < T_{amb} < +125\text{ °C}$		80		
		$I_{LOAD} = \pm 2\text{ mA}$ $-40\text{ °C} < T_{amb} < +85\text{ °C}$			70	
I_{SC}	Short-circuit current sourcing/sinking			35		mA
I_Q	Quiescent current			3.9	7	μA
		$-40\text{ °C} < T_{amb} < +85\text{ °C}$		4.4	7.5	
		$-40\text{ °C} < T_{amb} < +125\text{ °C}$		4.8	10	
C_{OUT}	Capacitive load		0.1		10	μF
T_{ON}	Turn-on settling time	to 0.1 %, $C_{OUT} = 1\text{ }\mu\text{F}$		2		ms
e_n	Noise floor	$f = 0.1\text{ Hz to } 10\text{ Hz}$		67		μV_{P-P}

Table 8. Electrical characteristics for TS3333

Symbol	Parameter	Test conditions	Min.	Typ.	Max.	Unit
V _{OUT}	Output voltage	V _{IN} = 5 V		3.3		V
	Initial accuracy	I _{LOAD} = 0 mA T _{amb} = 25 °C	-0.15		0.15	%
ΔV _{OUT} /ΔT	Average temperature coefficient	-40 °C < T _{amb} < +85 °C		9	30	ppm/°C
		-40 °C < T _{amb} < +125 °C		8	30	
ΔV _{OUT} /ΔV _{IN}	Line regulation	V _{IN} = 3.5 V to 5.5 V	-50	6	+50	ppm/V
		0 °C < T _{amb} < 70 °C		6		
		-40 °C < T _{amb} < +85 °C		8		
		-40 °C < T _{amb} < +125 °C		30		
ΔV _{OUT} /ΔI _{LOAD}	Load regulation	V _{IN} = 3.5 V	-50	6	+50	ppm/mA
		I _{LOAD} = ±5 mA 0 °C < T _{amb} < 70 °C		10		
		-40 °C < T _{amb} < +85 °C		20		
		-40 °C < T _{amb} < +125 °C		20		
V _{DROP}	Minimum dropout voltage	I _{LOAD} = ±5 mA		50	100	mV
		0 °C < T _{amb} < 70 °C		70		
		-40 °C < T _{amb} < +85 °C		75		
		-40 °C < T _{amb} < +125 °C		80		
		I _{LOAD} = ±2 mA -40 °C < T _{amb} < +85 °C			70	
I _{SC}	Short-circuit current sourcing/ sinking			35		mA
I _Q	Quiescent current			3.9	7	μA
		-40 °C < T _{amb} < +85 °C		4.4	7.5	
		-40 °C < T _{amb} < +125 °C		4.8	10	
C _{OUT}	Capacitive load		0.1		10	μF
T _{ON}	Turn-on settling time	to 0.1 %, C _{OUT} = 1 μF		2		ms
e _n	Noise floor	f = 0.1 Hz to 10 Hz		73		μV _{P-P}

5 Typical performance characteristics

The following plots are referred to the typical application circuit and, unless otherwise noted, at $T_A = 25\text{ }^\circ\text{C}$, $V_{OUT} = 3.0\text{ V}$.

Figure 3. Output voltage vs. temperature

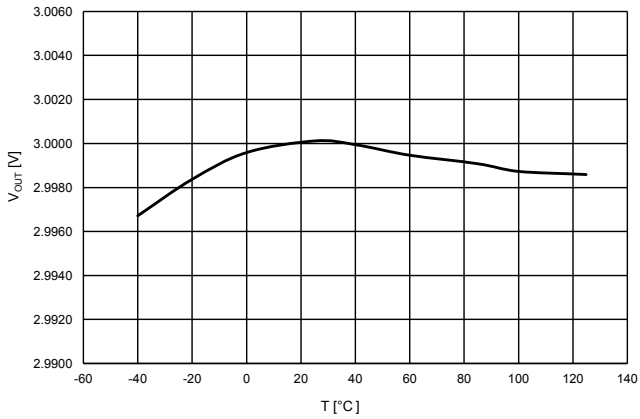

GAMG251120160930MT

Figure 4. Output voltage vs. input voltage

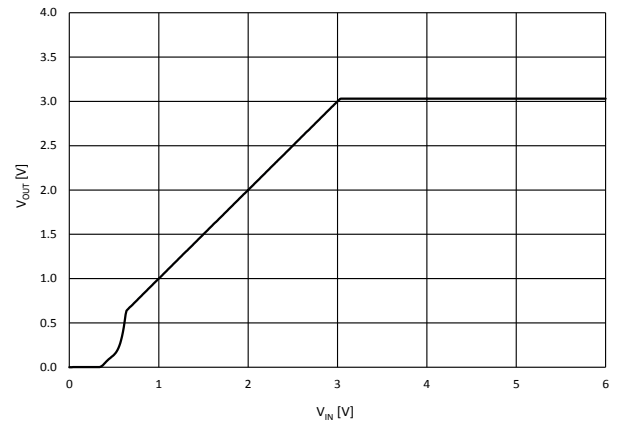

GAMG251120160931MT

Figure 5. Quiescent current vs. input voltage

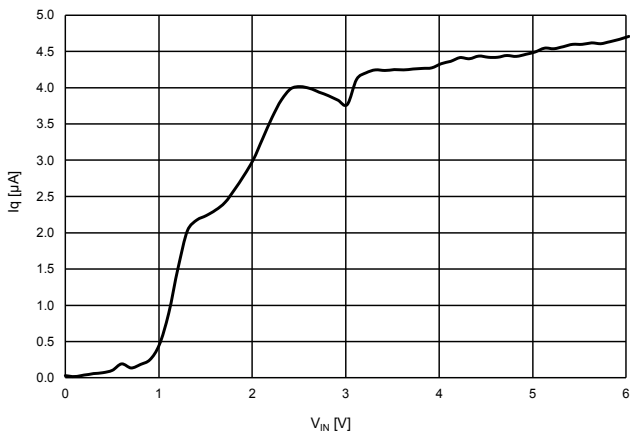

GAMG251120160932MT

Figure 6. Dropout voltage vs. load current

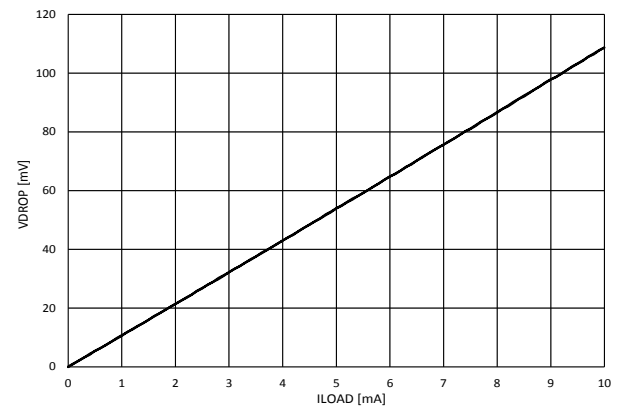

GAMG251120160933MT

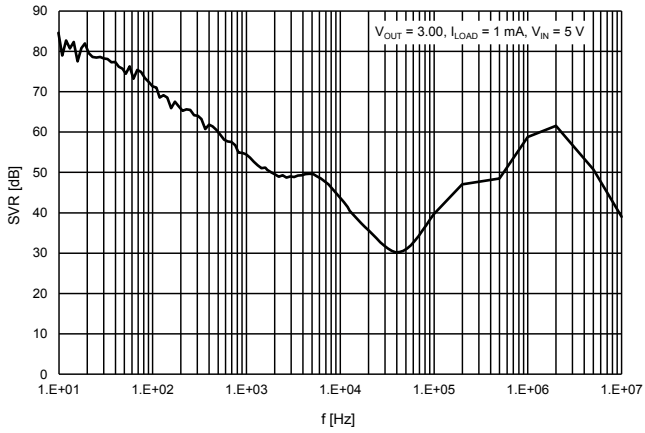
Figure 7. SVR vs. frequency

GAMG251120160934MT

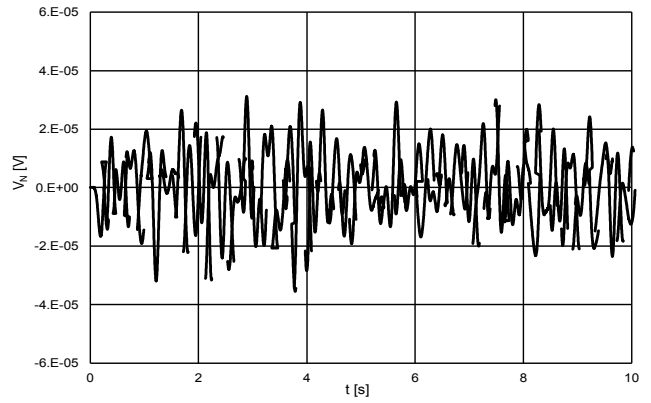
Figure 8. Low frequency noise

 $V_N = f(t)$, $V_{OUT} = 3.00$ V, $f = 0.1 - 10$ Hz

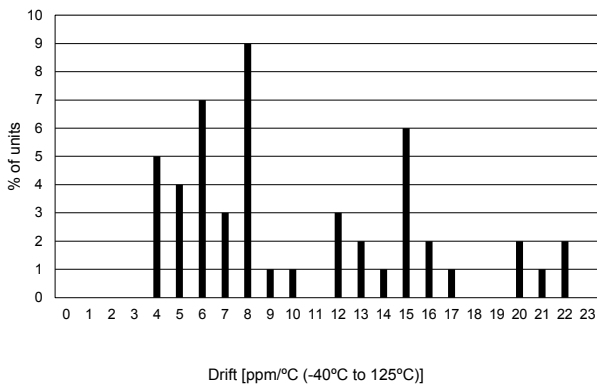
GAMG251120160935MT

Figure 9. Temperature drift

Drift [ppm/°C (-40°C to 125°C)]

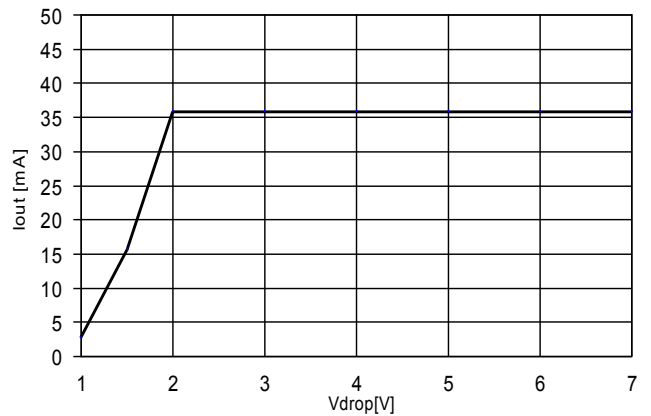
GAMG251120160936MT

Figure 10. Short-circuit current vs. dropout voltage

 $T = 25$ °C, $C_{in} = 1$ μ F, $C_{out} = 1$ μ F

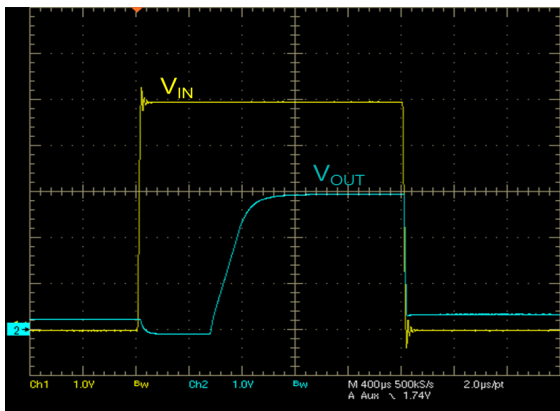
GAMG251120160937MT

Figure 11. Startup transient (no load)

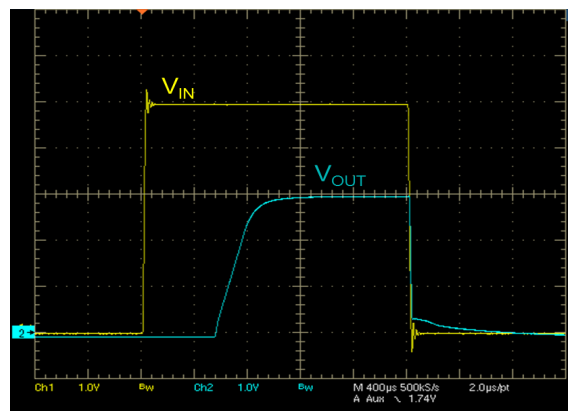
 V_{IN} from 0 to 5V, $V_{OUT}=3$ V, $I_{OUT}=0$ mA, $C_{IN} = C_{OUT} = 1$ μ F

GAMG251120160938MT

Figure 12. Startup transient ($I_{OUT} = 5$ mA)

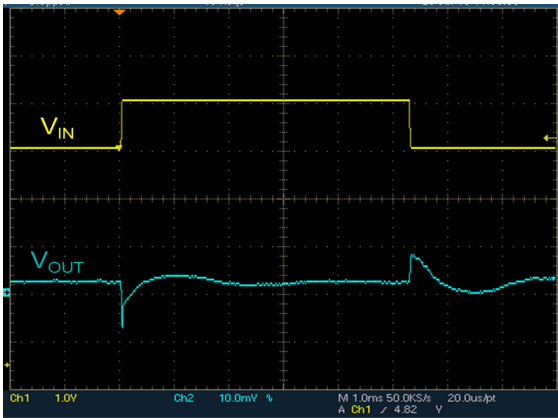
 V_{IN} from 0 to 5V, $V_{OUT}=3$ V, $I_{OUT}=5$ mA, $C_{IN} = C_{OUT} = 1$ μ F

GAMG251120160939MT

Figure 13. Line transient (no load)

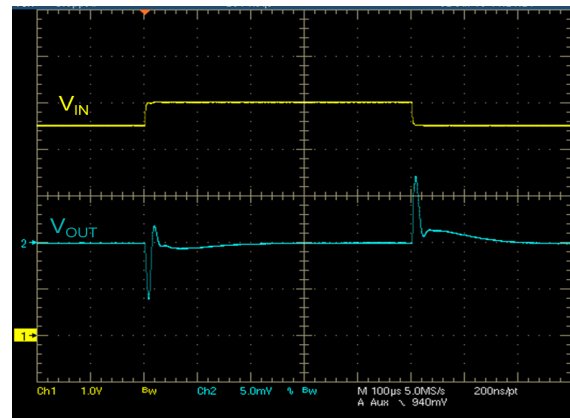
 $V_{IN} = 5V, V_{OUT} = 3V, I_{OUT} = 0mA, C_{OUT} = 1\mu F, \Delta V_{IN} = 500mV$

GAMG251120160940MT

Figure 14. Line transient ($I_{OUT} = 1\text{ mA}$)

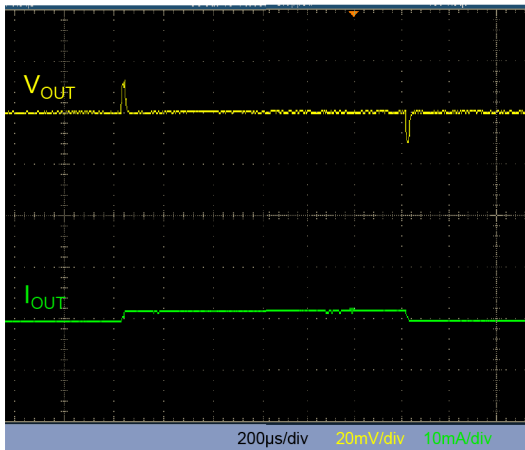
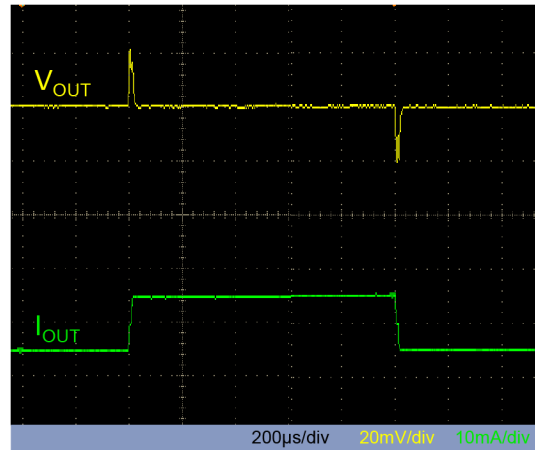
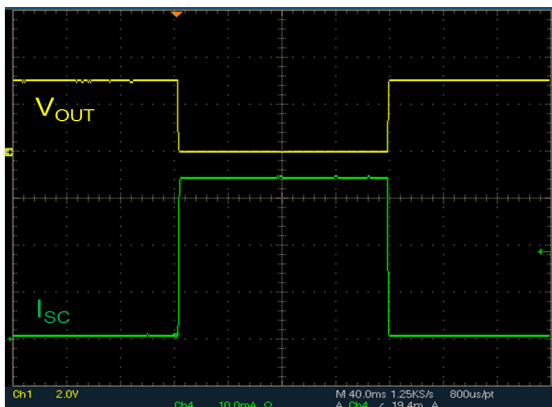
 $V_{IN} = 5V, V_{OUT} = 3V, I_{OUT} = 1mA, C_{OUT} = 1\mu F, \Delta V_{IN} = 500mV$

GAMG251120160941MT

Figure 15. Load transient ($I_{OUT} = \pm 1\text{ mA}$)

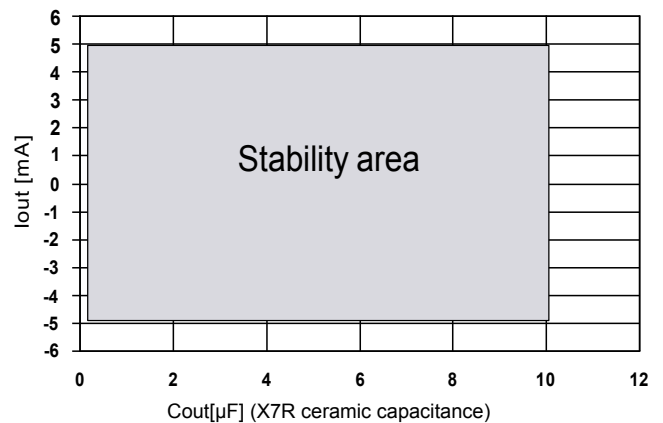
 $V_{OUT} = 3V, I_{OUT} = \pm 1mA, C_{IN} = C_{OUT} = 1\mu F$
Figure 16. Load transient ($I_{OUT} = \pm 5\text{ mA}$)

 $V_{OUT} = 3V, I_{OUT} = \pm 5mA, C_{IN} = C_{OUT} = 1\mu F$
Figure 17. Short-circuit response

 $V_{IN} = 5V, T = 25^\circ C, C_{IN} = 1\mu F, C_{OUT} = 1\mu F$

GAMG251120160944MT

Figure 18. Stability plan

GAMG251120160945MT

6 Package information

In order to meet environmental requirements, ST offers these devices in different grades of **ECOPACK** packages, depending on their level of environmental compliance. ECOPACK specifications, grade definitions and product status are available at: www.st.com. ECOPACK is an ST trademark.

6.1 QFN-8 package information

Figure 19. QFN8 package outline

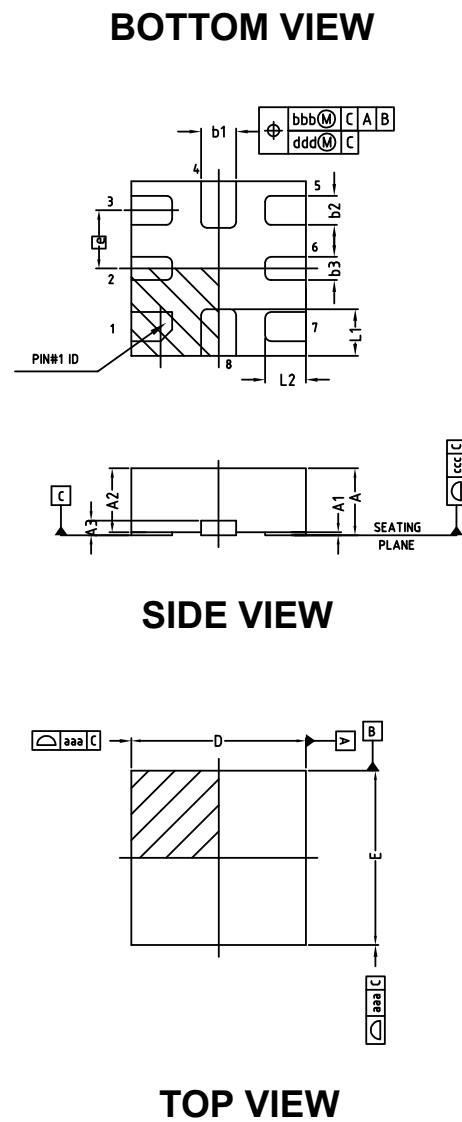

DM00182817_A

Table 9. QFN8 mechanical data

Dim.	mm			Note
	Min.	Typ.	Max.	
A	0.40	-	0.55	4
A1	0.00	-	0.05	12
A2	0.33	0.43	0.53	4
A3		-		4
b1	0.25	0.3	0.35	4.9
b2	0.20	0.25	0.30	
b3	0.15	0.20	0.25	
D	1.40	1.50	1.60	4
e		0.50		4
E	1.40	1.50	1.60	4
L1	0.30	0.40	0.50	4
L2	0.25	0.35	0.45	4
N		8		15

Table 10. QFN8 tolerance of form and position

Symbol	Tolerance of form and position
aaa	0.15
bbb	0.10
ccc	0.08
ddd	0.05
eee	0.10

Figure 20. QFN8 recommended footprint

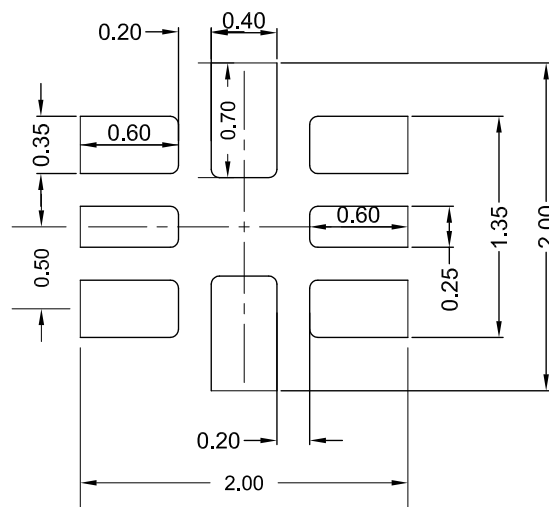

DM00182817_A

6.2 SOT23-3L package information

Figure 21. SOT23-3L package outline

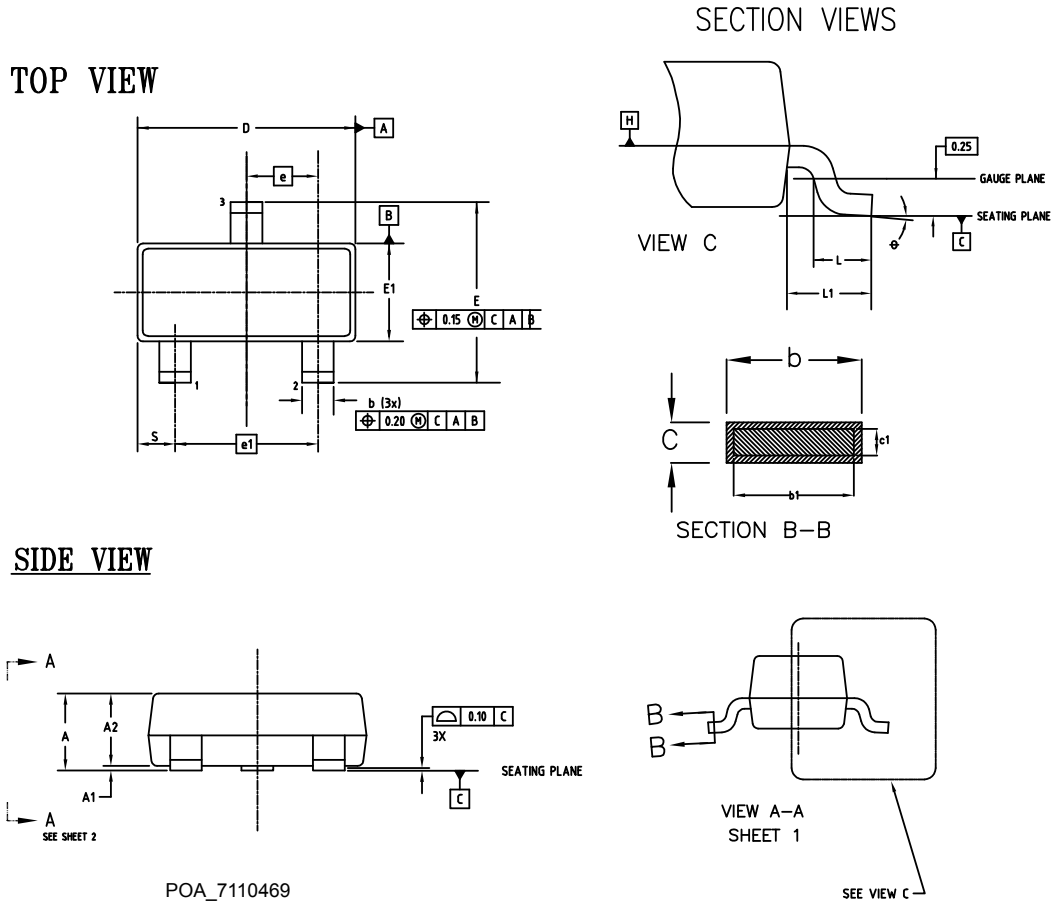
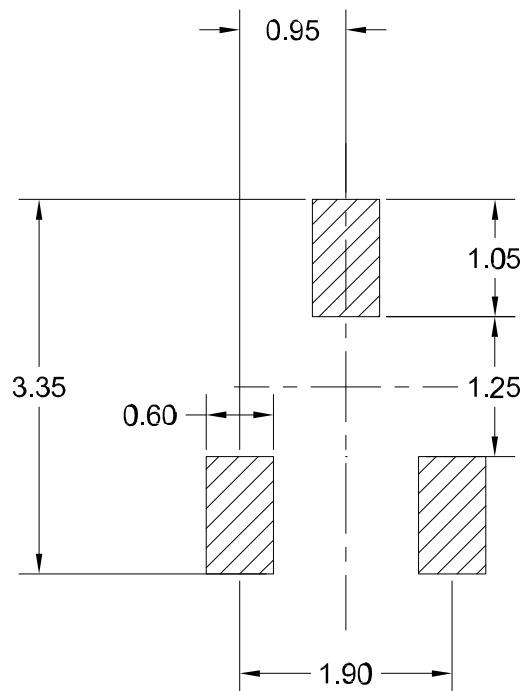

Table 11. SOT23-3L mechanical data

Dim.	mm		
	Min.	Typ.	Max.
A	0.89		1.12
A1	0.013		0.10
A2	0.88	0.95	1.02
b	0.37		0.50
b1	0.37	0.40	0.45
c	0.085		0.18
c1	0.085		0.16
D	2.80		3.04
E	2.10		2.64
E1	1.20		1.40
e	0.95BSC		
e1	1.90 BSC		
*L	0.28	0.38	0.48
L1	0.55		
R	0.05		
R1	0.05		
q	0°		8°
s	0.45		0.60

Figure 22. SOT23-3L recommended footprint



6.3 SOT323-3L package information

Figure 23. SOT323-3L package outline

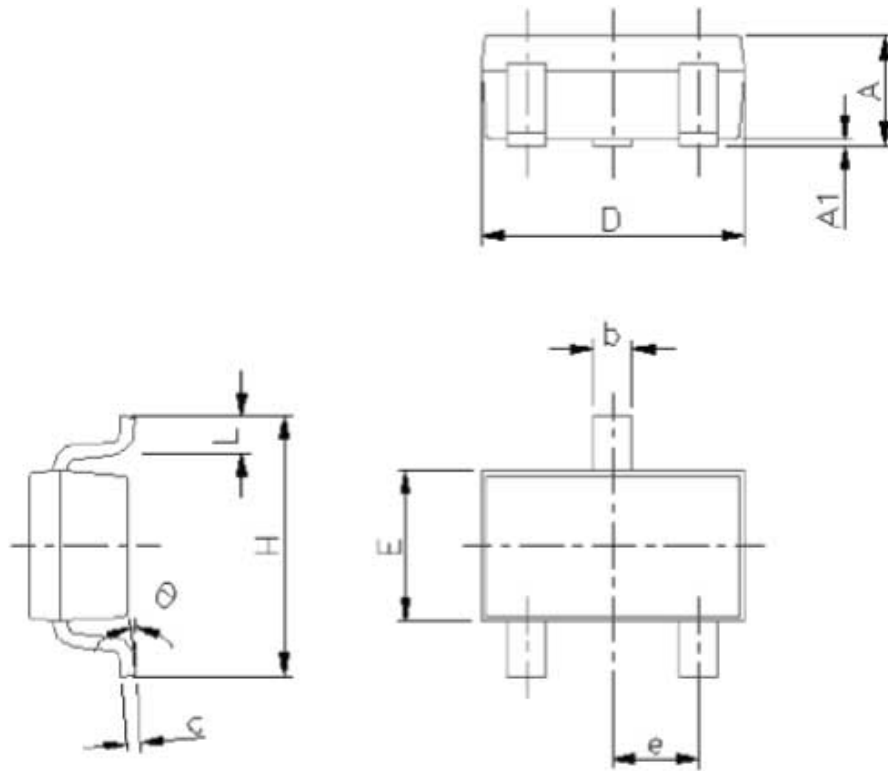
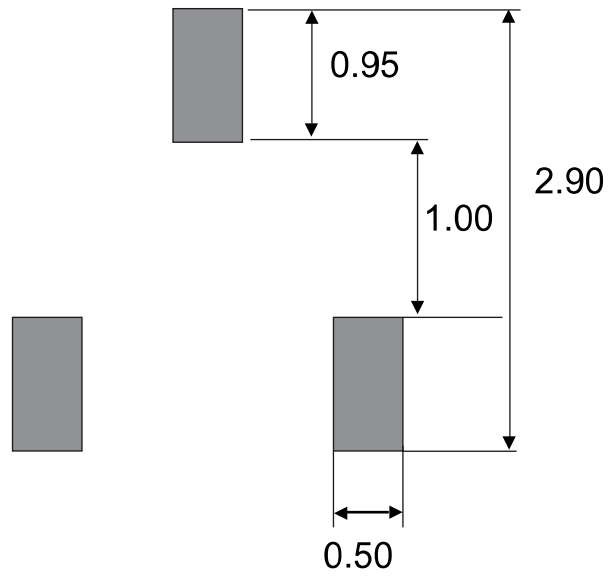

Table 12. SOT323-3L mechanical data

Dim.	mm		
	Min.	Typ.	Max.
A	0.80		1.10
A1	0.00		0.10
b	0.25		0.40
c	0.10		0.18
D	1.80		2.20
E	1.15		1.35
e	0.60	0.65	0.70
H	1.80		2.40
L	0.10		0.30

Figure 24. SOT323-3L recommended footprint



7 Ordering information

Table 13. Order codes

Part number	Output voltage (V)	Precision	Package	Temperature range
TS3312AQPR	1.25	±0.15 %	QFN8	-40 to +125 °C
TS3320AQPR	2.048			
TS3325AQPR	2.5			
TS3330AQPR	3.0			
TS3333AQPR	3.3			
TS3312ACR	1.25	±0.15 %	SOT323-3L	-40 to +125 °C
TS3320ACR	2.048			
TS3325ACR	2.5			
TS3330ACR	3			
TS3333ACR	3.3			
TS3312AMR	1.25	±0.15 %	SOT23-3L	-40 to +125 °C
TS3320AMR	2.048			
TS3325AMR	2.5			
TS3330AMR	3			
TS3333AMR	3.3			

Revision history

Table 14. Document revision history

Date	Revision	Changes
05-Sep-2017	1	Initial release.
26-Sep-2018	2	Added new order codes TS3325AQPR and TS3333AQPR in Table 9. Order codes.
16-Mar-2020	3	Added Table 5. Electrical characteristics for TS3325. Removed footnote in Table 10.
04-Aug-2021	4	Added new packages SOT23-3L and SOT323-3L Section 6.2 , Section 6.3 , new Table 5 new order code in Section 7.
07-Dic-2021	5	Removed footnote Table 13. Order codes

Contents

1	Pin configuration	2
2	Maximum ratings	3
3	Typical application	4
4	Electrical characteristics	5
5	Typical performance characteristics	10
6	Package information	13
	6.1 QFN8 package information	13
	6.2 SOT23-3L package information	15
	6.3 SOT323-3L package information	17
7	Ordering information	19
	Revision history	20
	List of tables	22
	List of figures	23

List of tables

Table 1.	Absolute maximum ratings	3
Table 2.	Thermal data	3
Table 3.	Recommended operating conditions	3
Table 4.	Electrical characteristics for TS3312	5
Table 5.	Electrical characteristics for TS3320	6
Table 6.	Electrical characteristics for TS3325	7
Table 7.	Electrical characteristics for TS3330	8
Table 8.	Electrical characteristics for TS3333	9
Table 9.	QFN8 mechanical data	14
Table 10.	QFN8 tolerance of form and position	14
Table 11.	SOT23-3L mechanical data	16
Table 12.	SOT323-3L mechanical data	17
Table 13.	Order codes	19
Table 14.	Document revision history	20

List of figures

Figure 1.	Pin configuration (top view)	2
Figure 2.	Typical application circuit	4
Figure 3.	Output voltage vs. temperature	10
Figure 4.	Output voltage vs. input voltage	10
Figure 5.	Quiescent current vs. input voltage	10
Figure 6.	Dropout voltage vs. load current	10
Figure 7.	SVR vs. frequency	11
Figure 8.	Low frequency noise	11
Figure 9.	Temperature drift.	11
Figure 10.	Short-circuit current vs. dropout voltage	11
Figure 11.	Startup transient (no load)	11
Figure 12.	Startup transient ($I_{OUT} = 5 \text{ mA}$)	11
Figure 13.	Line transient (no load)	12
Figure 14.	Line transient ($I_{OUT} = 1 \text{ mA}$)	12
Figure 15.	Load transient ($I_{OUT} = +/-1 \text{ mA}$)	12
Figure 16.	Load transient ($I_{OUT} = +/-5 \text{ mA}$)	12
Figure 17.	Short-circuit response	12
Figure 18.	Stability plan	12
Figure 19.	QFN8 package outline	13
Figure 20.	QFN8 recommended footprint.	14
Figure 21.	SOT23-3L package outline	15
Figure 22.	SOT23-3L recommended footprint	16
Figure 23.	SOT323-3L package outline	17
Figure 24.	SOT323-3L recommended footprint.	18

IMPORTANT NOTICE – PLEASE READ CAREFULLY

STMicroelectronics NV and its subsidiaries (“ST”) reserve the right to make changes, corrections, enhancements, modifications, and improvements to ST products and/or to this document at any time without notice. Purchasers should obtain the latest relevant information on ST products before placing orders. ST products are sold pursuant to ST’s terms and conditions of sale in place at the time of order acknowledgement.

Purchasers are solely responsible for the choice, selection, and use of ST products and ST assumes no liability for application assistance or the design of Purchasers’ products.

No license, express or implied, to any intellectual property right is granted by ST herein.

Resale of ST products with provisions different from the information set forth herein shall void any warranty granted by ST for such product.

ST and the ST logo are trademarks of ST. For additional information about ST trademarks, please refer to www.st.com/trademarks. All other product or service names are the property of their respective owners.

Information in this document supersedes and replaces information previously supplied in any prior versions of this document.

© 2021 STMicroelectronics – All rights reserved

X-ON Electronics

Largest Supplier of Electrical and Electronic Components

Click to view similar products for [Voltage References](#) category:

Click to view products by [STMicroelectronics](#) manufacturer:

Other Similar products are found below :

[REF01J/883](#) [5962-8686103XC](#) [NCV431BVDMR2G](#) [LT6654AMPS6-2.048#TRMPBF](#) [SCV431AIDMR2G](#) [LT1019AIS8-2.5](#) [SC431ILPRAG](#)
[AP432AQG-7](#) [NJM2823F-TE1](#) [TL431-A](#) [MCP1502T-18E/CHY](#) [MCP1502T-40E/CHY](#) [TL431ACZ](#) [KA431SLMF2TF](#) [KA431SMF2TF](#)
[KA431SMFTF](#) [LM4040QCEM3-3.0/NOPB](#) [LM4041C12ILPR](#) [LM4120AIM5-2.5/NOP](#) [LM431SCCMFX](#) [TS3330AQPR](#) [REF5040MDREP](#)
[REF3012AIDBZR](#) [LM285BXM3-1.2/NOPB](#) [LM385BM-2.5/NOPB](#) [LM4040AIM3-10.0](#) [LM4040BIM3-4.1](#) [LM4040CIM3-10.0](#)
[LM4040CIM3X-2.0/NOPB](#) [LM4041BSD-122GT3](#) [LM4041QDIM3-ADJ/NO](#) [LM4050QAEM3X4.1/NOPB](#) [LM4051BIM3-ADJ/NOPB](#)
[LM4051CIM3X-1.2/NOPB](#) [LM4128CMF-1.8/NOPB](#) [LM4132DMF-1.8/NOPB](#) [LM4132EMF-1.8/NOPB](#) [LM4132EMF-2.0/NOPB](#)
[LM4140CCMX-1.2/NOPB](#) [LM431CIM](#) [LM385BD-2.5R2G](#) [LM385M-2.5/NOPB](#) [LM4030AMF-4.096/NOPB](#) [LM4040D30ILPR](#)
[LM4051CIM3X-ADJ/NOPB](#) [AP432YG-13](#) [AS431ANTR-G1](#) [AS431BZTR-E1](#) [AN431AN-ATRG1](#) [AP431IBNTR-G1](#)