

Micropower quad CMOS voltage comparator

Datasheet - production data

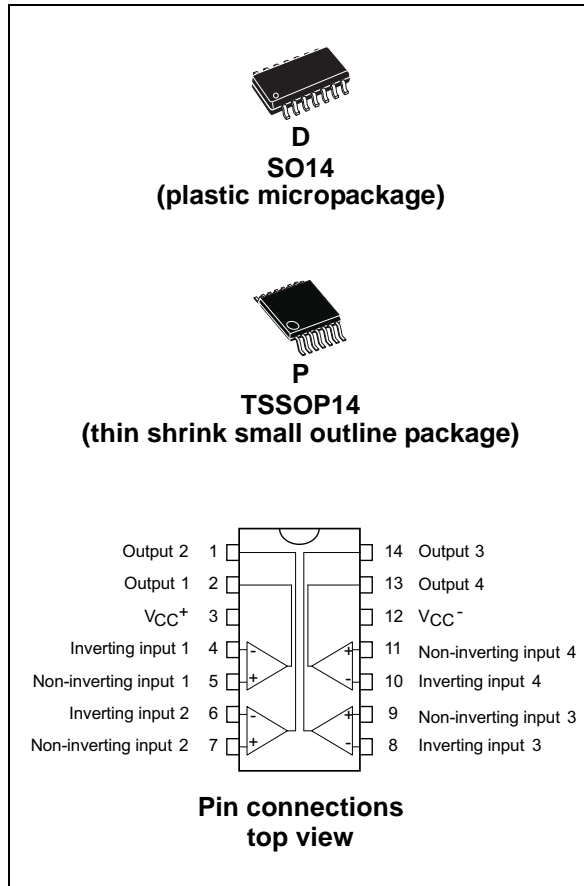

Features

- Extremely low supply current: 9 μ A typ./comparator
- Wide single supply range 2.7 V to 16 V or dual supplies (± 1.35 V to ± 8 V)
- Extremely low input bias current: 1 pA typ.
- Extremely low input offset current: 1 pA typ.
- Input common-mode voltage range includes GND
- High input impedance: 10^{12} Ω typ.
- Fast response time: 1.5 μ s typ. for 5 mV overdrive
- Pin-to-pin and functionally compatible with bipolar LM339 device

Description

The TS339 device is a micro-power, CMOS, quad voltage comparator with extremely low consumption of 9 μ A typ./comparator (20 times less than the bipolar LM339). Similar performances are offered by the quad micro-power comparator TS3704 with a push-pull CMOS output. Thus response times remain similar to the LM339 device.

Table 1. Device summary

Order code	Temperature range	Package	Packaging	Marking
TS339CDT	0 °C, 70 °C	SO14	Tape and reel	S339C
TS339CPT		TSSOP14		
TS339IDT	-40 °C, 125 °C	SO14		S339I
TS339IPT		TSSOP14		

Contents

1	Absolute maximum ratings	3
2	Typical application schematics	4
3	Electrical characteristics	5
4	Package information	7
	4.1 SO14 package	8
	4.2 TSSOP14 package	9
5	Revision history	10



1 Absolute maximum ratings

Table 2. Key parameters and their absolute maximum ratings

Symbol	Parameter	Value	Unit
V_{CC}^+	Supply voltage ⁽¹⁾	18	V
V_{id}	Differential input voltage ⁽²⁾	± 18	
V_i	Input voltage ⁽³⁾	18	
V_o	Output voltage	18	
I_o	Output current	20	mA
I_F	Forward current in ESD protection diodes on inputs ⁽⁴⁾	50	
P_d	Power dissipation ⁽⁵⁾		mW
		SO14 TSSOP14	
T_{stg}	Storage temperature range	-65 to +150	°C
ESD	HBM: human body model ⁽⁶⁾	50	V
	MM: machine model ⁽⁷⁾	40	
	CDM: charged device model	800	

- All voltage values, except the differential voltage, are with respect to network ground terminal.
- Differential voltages are the non-inverting input terminal with respect to the inverting input terminal.
- Excursions of input voltages may exceed the power supply level. As long as the common mode voltage [$V_{icm}=(V_{in}^+ + V_{in}^-)/2$] remains within the specified range, the comparator will provide a stable output state. However, the maximum current through the ESD diodes (I_F) of the input stage must strictly be observed.
- Guaranteed by design.
- P_d is calculated with $T_{amb} = +25\text{ °C}$, $T_j = +150\text{ °C}$ and
 $R_{thja} = 150\text{ °C/W}$ for SO14 package
 $R_{thja} = 175\text{ °C/W}$ for TSSOP14 package.
- Human body model, 100pF discharged through a 1.5 k Ω resistor into pin of device.
- Machine model ESD, a 200 pF cap is charged to the specified voltage, then discharged directly into the IC with no external series resistor (internal resistor < 5 Ω), into pin to pin of device.

2 Typical application schematics

Figure 1. Schematic diagram (for 1/4 TS339)

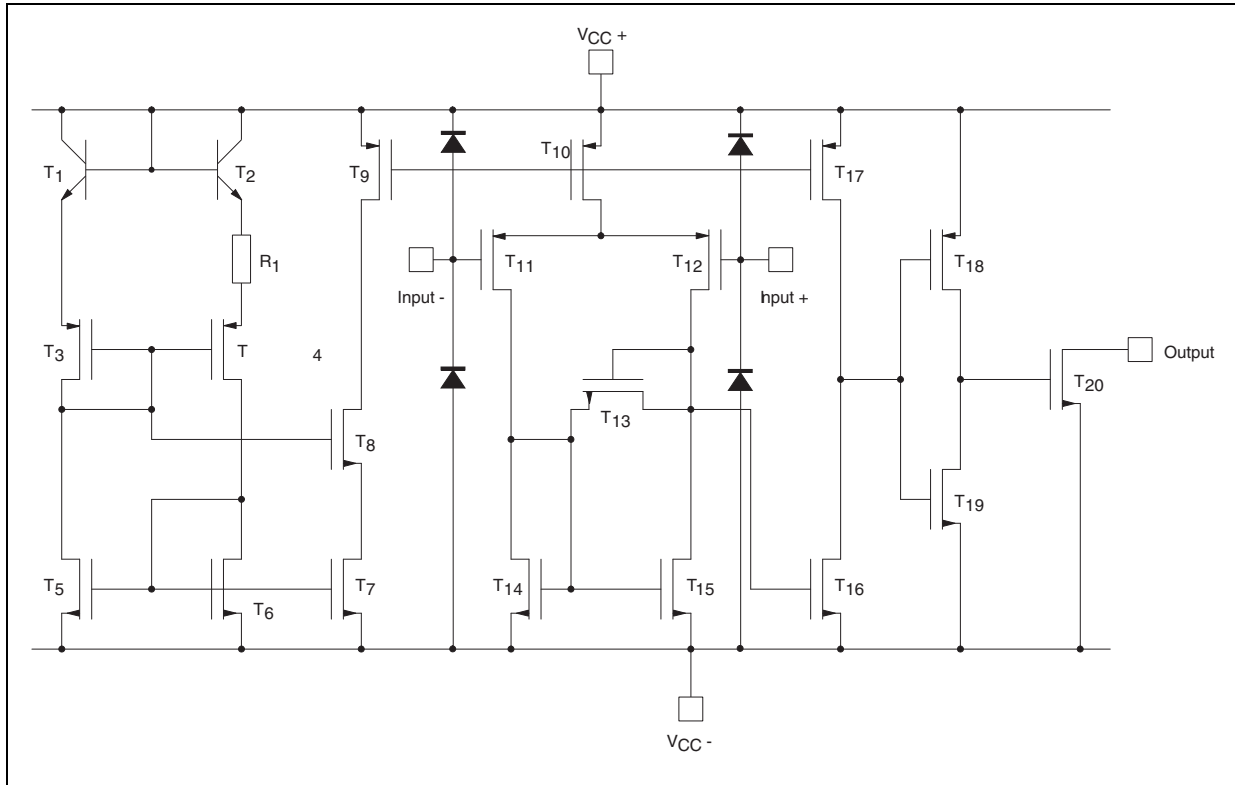

3 Electrical characteristics

Table 3. $V_{CC}^+ = 3\text{ V}$, $V_{CC}^- = 0\text{ V}$, $T_{amb} = 25\text{ }^\circ\text{C}$ (unless otherwise specified)

Symbol	Parameter	Min.	Typ.	Max.	Unit
V_{io}	Input offset voltage ⁽¹⁾ $V_{ic} = 1.5\text{ V}$ $T_{min.} \leq T_{amb} \leq T_{max.}$			5 6.5	mV
I_{io}	Input offset current ⁽²⁾ $V_{ic} = 1.5\text{ V}$ $T_{min.} \leq T_{amb} \leq T_{max.}$		1	300	pA
I_{ib}	Input bias current ⁽²⁾ $V_{ic} = 1.5\text{ V}$ $T_{min.} \leq T_{amb} \leq T_{max.}$		1	600	
V_{icm}	Input common mode voltage range $T_{min.} \leq T_{amb} \leq T_{max.}$	0 0		$V_{CC}^+ - 1.2$ $V_{CC}^+ - 1.5$	V
CMR	Common-mode rejection ratio $V_{ic} = V_{icm\ min.}$		70		dB
SVR	Supply voltage rejection ratio $V_{CC}^+ = 3\text{ V to } 5\text{ V}$		70		
I_{OH}	High level output current $V_{id} = +1\text{ V}$, $V_{OH} = 3\text{ V}$ $T_{min.} \leq T_{amb} \leq T_{max.}$		2	40 1000	nA
V_{OL}	Low level output voltage $V_{id} = -1\text{ V}$, $I_{OL} = +6\text{ mA}$ $T_{min.} \leq T_{amb} \leq T_{max.}$		400	550 800	mV
I_{CC}	Supply current (each comparator) No load - outputs low $T_{min.} \leq T_{amb} \leq T_{max.}$		9	20 25	μA
t_{PLH}	Response time low to high $V_{ic} = 0\text{ V}$, $f = 10\text{ kHz}$, $T_{min.} \leq T_{amb} \leq T_{max.}$, $C_L = 50\text{ pF}$, overdrive = 5 mV TTL input		1.5 0.7		μs
t_{PHL}	Response time high to low $V_{ic} = 0\text{ V}$, $f = 10\text{ kHz}$, $R_L = 5.1\text{ k}\Omega$, $C_L = 50\text{ pF}$, overdrive = 5 mV TTL input		2.5 0.08		

1. The specified offset voltage is the maximum value required to drive the output up to 2.5 V or down to 0.3 V.
2. Maximum values including unavoidable inaccuracies of the industrial test.

Table 4. $V_{CC}^+ = 5\text{ V}$, $V_{CC}^- = 0\text{ V}$, $T_{amb} = 25\text{ }^\circ\text{C}$ (unless otherwise specified)

Symbol	Parameter	Min.	Typ.	Max.	Unit
V_{io}	Input offset voltage ⁽¹⁾ $V_{ic} = 2.5\text{ V}$, $V_{CC}^+ = 5\text{ V to }10\text{ V}$ $T_{min.} \leq T_{amb} \leq T_{max.}$		1.4	5 6.5	mV
I_{io}	Input offset current ⁽²⁾ $V_{ic} = 2.5\text{ V}$ $T_{min.} \leq T_{amb} \leq T_{max.}$		1	300	pA
I_{ib}	Input bias current ⁽²⁾ $V_{ic} = 2.5\text{ V}$ $T_{min.} \leq T_{amb} \leq T_{max.}$		1	600	
V_{icm}	Input common mode voltage range $T_{min.} \leq T_{amb} \leq T_{max.}$	0 0		$V_{CC}^+ - 1.2$ $V_{CC}^+ - 1.5$	V
CMR	Common-mode rejection ratio $V_{ic} = 0\text{ V}$		75		dB
SVR	Supply voltage rejection ratio $V_{CC}^+ = +5\text{ V to }+10\text{ V}$		85		
I_{OH}	High level output voltage $V_{id} = 1\text{ V}$, $V_{OH} = +5\text{ V}$ $T_{min.} \leq T_{amb} \leq T_{max.}$		27	40 1000	nA
V_{OL}	Low level output voltage $V_{id} = -1\text{ V}$, $I_{OL} = 6\text{ mA}$ $T_{min.} \leq T_{amb} \leq T_{max.}$		260	400 650	mV
I_{CC}	Supply current (each comparator) No load - outputs low $T_{min.} \leq T_{amb} \leq T_{max.}$		10	20 25	μA
t_{PLH}	Response time low to high $V_{ic} = 0\text{ V}$, $f = 10\text{ kHz}$, $R_L = 5.1\text{ k}\Omega$, $C_L = 15\text{ pF}$, overdrive = 5 mV Overdrive = 10 mV Overdrive = 20 mV Overdrive = 40 mV TTL input		1.5		μs
			1.2		
			1.1		
			0.9		
			0.8		
t_{PHL}	Response time high to low $V_{ic} = 0\text{ V}$, $f = 10\text{ kHz}$, $R_L = 5.1\text{ k}\Omega$, $C_L = 15\text{ pF}$, overdrive = 5 mV Overdrive = 10 mV Overdrive = 20 mV Overdrive = 40 mV TTL input		2.5		μs
			1.9		
			1.2		
			0.8		
			0.08		
t_f	Fall time $f = 10\text{ kHz}$, $C_L = 50\text{ pF}$, $R_L = 5.1\text{ k}\Omega$, overdrive 50 mV		30		ns

1. The specified offset voltage is the maximum value required to drive the output up to 4.5 V or down to 0.3 V.

2. Maximum values including unavoidable inaccuracies of the industrial test.

4 Package information

In order to meet environmental requirements, ST offers these devices in different grades of ECOPACK® packages, depending on their level of environmental compliance. ECOPACK specifications, grade definitions and product status are available at: www.st.com. ECOPACK is an ST trademark.

4.1 SO14 package information

Figure 2. SO14 package outline

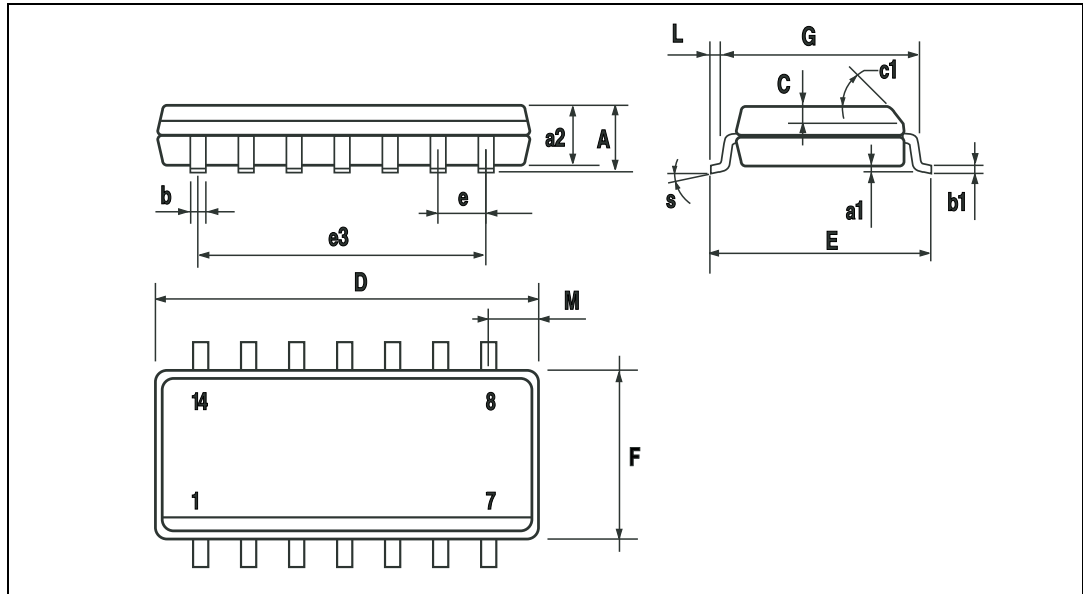

Table 5. SO14 package mechanical data

Symbol	Dimensions					
	mm			inch		
	Min.	Typ.	Max.	Min.	Typ.	Max.
A			1.75			0.068
a1	0.1		0.2	0.003		0.007
a2			1.65			0.064
b	0.35		0.46	0.013		0.018
b1	0.19		0.25	0.007		0.010
C		0.5			0.019	
c1	45° (typ.)					
D	8.55		8.75	0.336		0.344
E	5.8		6.2	0.228		0.244
e		1.27			0.050	
e3		7.62			0.300	
F	3.8		4.0	0.149		0.157
G	4.6		5.3	0.181		0.208
L	0.5		1.27	0.019		0.050
M			0.68			0.026
S	8° (max.)					

4.2 TSSOP14 package information

Figure 3. TSSOP14 package outline

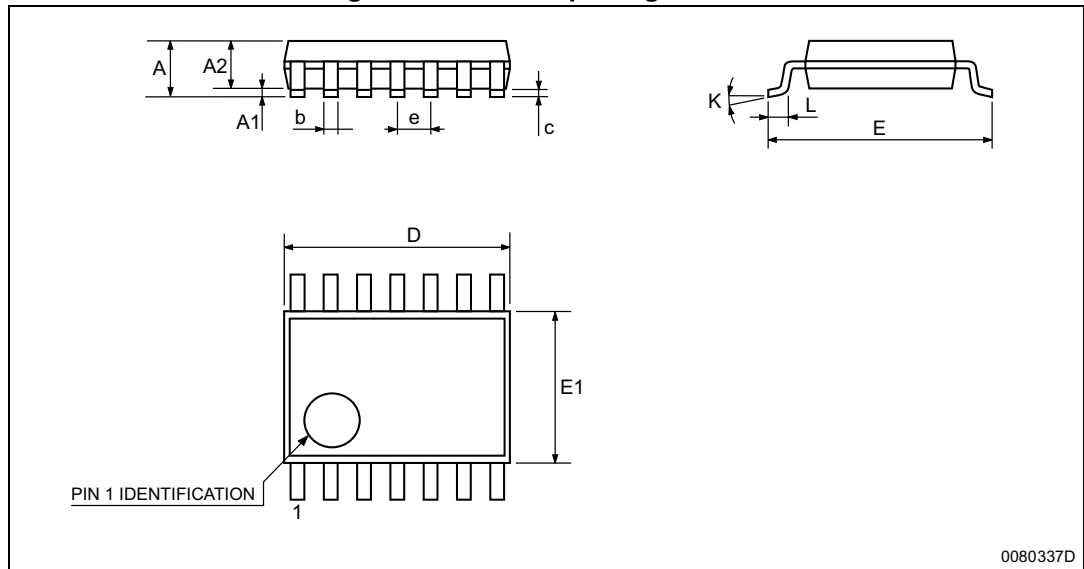

Table 6. TSSOP14 package mechanical data

Symbol	Dimensions					
	mm.			inch		
	Min.	Typ.	Max.	Min.	Typ.	Max.
A			1.2			0.047
A1	0.05		0.15	0.002	0.004	0.006
A2	0.8	1	1.05	0.031	0.039	0.041
b	0.19		0.30	0.007		0.012
c	0.09		0.20	0.004		0.0089
D	4.9	5	5.1	0.193	0.197	0.201
E	6.2	6.4	6.6	0.244	0.252	0.260
E1	4.3	4.4	4.48	0.169	0.173	0.176
e		0.65 BSC			0.0256 BSC	
K	0°		8°	0°		8°
L	0.45	0.60	0.75	0.018	0.024	0.030

5 Revision history

Table 7. Document revision history

Date	Revision	Changes
Jan. 2003	1	Initial release.
Aug. 2005	2	1 - PPAP references inserted in the datasheet see <i>Table 1: Order codes on page 1</i> . 2 - ESD protection inserted in <i>Table 2 Key parameters and their absolute maximum ratings on page 2</i> .
04-Sep-2012	3	Updated <i>Features, Table 1</i> , removed TS339IYD and TS339IYDT from <i>Table 1</i> . Updated ECOPACK text, reformatted <i>Section 4: Package information</i> . Minor corrections throughout document.
21-Feb-2014	4	Removed DIP package <i>Features</i> : updated fast response time <i>Device summary</i> : removed order codes TS339CN, TS339IN, and TS339ID; added temperature range for order codes TS339IDT and TS339IPT
16-Mar-2021	5	Updated the device summary table in cover page.

IMPORTANT NOTICE – PLEASE READ CAREFULLY

STMicroelectronics NV and its subsidiaries (“ST”) reserve the right to make changes, corrections, enhancements, modifications, and improvements to ST products and/or to this document at any time without notice. Purchasers should obtain the latest relevant information on ST products before placing orders. ST products are sold pursuant to ST’s terms and conditions of sale in place at the time of order acknowledgement.

Purchasers are solely responsible for the choice, selection, and use of ST products and ST assumes no liability for application assistance or the design of Purchasers’ products.

No license, express or implied, to any intellectual property right is granted by ST herein.

Resale of ST products with provisions different from the information set forth herein shall void any warranty granted by ST for such product.

ST and the ST logo are trademarks of ST. For additional information about ST trademarks, please refer to www.st.com/trademarks. All other product or service names are the property of their respective owners.

Information in this document supersedes and replaces information previously supplied in any prior versions of this document.

© 2021 STMicroelectronics – All rights reserved

X-ON Electronics

Largest Supplier of Electrical and Electronic Components

Click to view similar products for [Analog Comparators](#) category:

Click to view products by [STMicroelectronics](#) manufacturer:

Other Similar products are found below :

[SC2903VDR2G](#) [LM2901SNG](#) [LM339SNG](#) [55122](#) [5962-8757203IA](#) [NTE911](#) [5962-8751601DA](#) [LM339EDR2G](#) [NTE922](#) [SC2901DR2G](#)
[LM2903M/TR](#) [LM2903F-E2](#) [MCP6544-EP](#) [LM2901EDR2G](#) [TS391SN2T1G](#) [LM111JG](#) [LM239APT](#) [HMC675LC3CTR](#) [5962-8765801PA](#)
[MAX9024AUD+](#) [LT6700HVIS6-2#TRMPBF](#) [5962-8765902CA](#) [ADCMP394ARZ-RL7](#) [LM339AMX](#) [LTC1440IMS8#PBF](#) [AZV331KSTR-](#)
[G1](#) [LTC1841IS8#PBF](#) [LTC1440CN8#PBF](#) [LTC1542CS8#PBF](#) [LTC1445CS#PBF](#) [TL331VSN4T3G](#) [LT6700IDCB-1#TRMPBF](#)
[LTC1042CN8#PBF](#) [LTC1540CMS8#PBF](#) [LT6703CDC-2#TRMPBF](#) [ADCMP607BCPZ-R7](#) [LT1720CDD#PBF](#) [LTC1040CN#PBF](#)
[LT6700MPDCB-1#TRMPBF](#) [LT6700IDCB-3#TRMPBF](#) [LTC1440IS8#PBF](#) [S-89431ACNC-HBVTFG](#) [CMP402GSZ-REEL](#) [NTE1718](#)
[NTE943](#) [NTE943M](#) [NTE943SM](#) [TA75S393F,LF\(T](#) [ALD2301APAL](#) [ALD2302APAL](#)