

Precision low noise dual operational amplifier

Datasheet – production data

Features

- Large output voltage swing: +14.3 V/-14.6 V
- Low input offset voltage 850 μ V max.
- Low voltage noise: 4.5 nV/ $\sqrt{\text{Hz}}$
- High gain bandwidth product: 15 MHz
- High slew rate: 7 V/ μ s
- Low distortion: 0.002%
- ESD internal protection 2 kV
- Excellent frequency stability

Description

The TS522 device is a monolithic dual operational amplifier mainly dedicated to audio applications. The TS522 device offers a very low input offset voltage as well as low voltage noise (4.5 nV/ $\sqrt{\text{Hz}}$) and high dynamic performances (15 MHz gain bandwidth product, 7 V/ μ s slew rate).

The output stage allows a large output voltage swing and symmetrical source and sink currents.

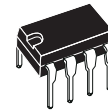

N
DIP8
(plastic package)

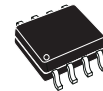

D
SO8
(plastic micropackage)

Pin connections top view

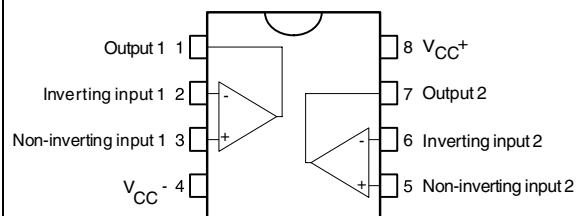

1 Absolute maximum ratings and operating conditions

Table 1. Absolute maximum ratings

Symbol	Parameter	Value	Unit
V_{CC}	Supply voltage	± 18 to 36	V
V_{id}	Differential input voltage ⁽¹⁾	± 30	V
V_i	Input voltage ⁽¹⁾	± 15	V
	Output short-circuit duration ⁽²⁾	Infinite	
T_j	Maximum junction temperature	+ 150	°C
T_{stg}	Storage temperature range	-65 to +150	°C
R_{thja}	Thermal resistance junction-to-ambient ^{(3), (4)}		°C/W
	SO-8	125	
	DIP8	85	
R_{thjc}	Thermal resistance junction-to-case ^{(3), (4)}		°C/W
	SO-8	40	
	DIP8	41	
ESD	HBM: human body model ⁽⁵⁾	2	kV
	MM: machine model ⁽⁶⁾	200	V
	CDM: charged device model ⁽⁷⁾	1.5	kV

1. Either or both input voltages must not exceed the magnitude of V_{CC}^+ or V_{CC}^- .
2. Power dissipation must be considered to ensure maximum junction temperature (T_j) is not exceeded.
3. Short-circuits can cause excessive heating and destructive dissipation.
4. R_{th} are typical values.
5. Human body model: a 100 pF capacitor is charged to the specified voltage, then discharged through a 1.5 k Ω resistor between two pins of the device. This is done for all couples of connected pin combinations while the other pins are floating.
6. Machine model: a 200 pF capacitor is charged to the specified voltage, then discharged directly between two pins of the device with no external series resistor (internal resistor < 5 Ω). This is done for all couples of connected pin combinations while the other pins are floating.
7. Charged device model: all pins and the package are charged together to the specified voltage and then discharged directly to ground through only one pin. This is done for all pins.

Table 2. Operating conditions

Symbol	Parameter	Value	Unit
V_{CC}	Supply voltage	± 2.5 to ± 15	V
T_{oper}	Operating free air temperature range	-40 to 125	°C

2 Schematic diagram

Figure 1. Typical schematic diagram (1/2 TS522)

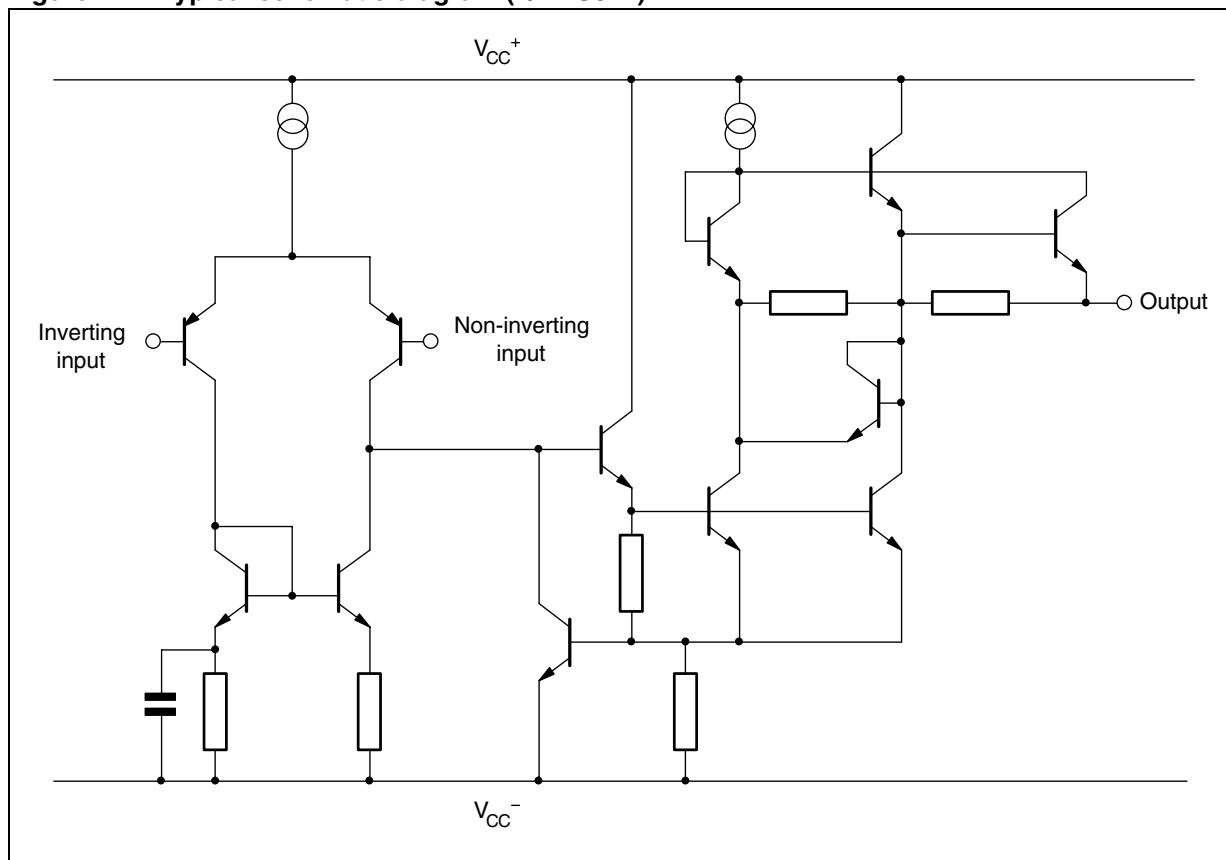

3 Electrical characteristics

Table 3. Electrical characteristics at $V_{CC+} = 15\text{ V}$, $V_{CC-} = -15\text{ V}$, $T_{amb} = 25\text{ °C}$ (unless otherwise specified)

Symbol	Parameter	Min.	Typ.	Max.	Unit
V_{io}	Input offset voltage ($V_o = 0\text{ V}$, $V_{ic} = 0\text{ V}$) $T_{amb} = +25\text{ °C}$ $T_{min} \leq T_{amb} \leq T_{max}$			0.85 1.7	mV
ΔV_{io}	Input offset voltage drift $V_{ic} = 0\text{ V}$, $V_o = 0\text{ V}$, $T_{min} \leq T_{amb} \leq T_{max}$		2		$\mu\text{V}/\text{°C}$
I_{io}	Input offset current ($V_{ic} = 0\text{ V}$, $V_o = 0\text{ V}$) $T_{amb} = +25\text{ °C}$ $T_{min} \leq T_{amb} \leq T_{max}$		10	150 175	nA
I_{ib}	Input bias current ($V_{ic} = 0\text{ V}$, $V_o = 0\text{ V}$) $T_{amb} = +25\text{ °C}$ $T_{min} \leq T_{amb} \leq T_{max}$		250	750 800	nA
V_{icm}	Common mode input voltage range ($\Delta V_{io} = 5\text{ mV}$, $V_o = 0\text{ V}$)	± 13	± 14		V
A_{vd}	Large signal voltage gain ($R_L = 2\text{ k}\Omega$, $V_o = \pm 10\text{ V}$) $T_{amb} = +25\text{ °C}$ $T_{min} \leq T_{amb} \leq T_{max}$	90 85	100		dB
$\pm V_{opp}$	Output voltage swing ($V_{id} = \pm 1\text{ V}$) $R_L = 600\ \Omega$ $R_L = 600\ \Omega$ $R_L = 2.0\text{ k}\Omega$ $R_L = 2.0\text{ k}\Omega$ $R_L = 10\text{ k}\Omega$ $R_L = 10\text{ k}\Omega$		12.2 -12.7 14 -14.2 14.3 -14.6		V
CMR	Common mode rejection ratio ($V_{ic} = \pm 13\text{ V}$)	80	100		dB
SVR	Supply voltage rejection ratio $V_{CC+}/V_{CC-} = +15\text{ V}/-15\text{ V}$ to $+5\text{ V}/-5\text{ V}$	80	105		dB
I_o	Output short-circuit current ($V_{id} = \pm 1\text{ V}$, output to ground) Source Sink	15 20	29 37		mA
I_{CC}	Supply current ($V_o = 0\text{ V}$, all amplifiers) $T_{amb} = +25\text{ °C}$ $T_{min} \leq T_{amb} \leq T_{max}$		4	5 5.5	mA
SR	Slew rate ($V_i = -10\text{ V}$ to $+10\text{ V}$, $R_L = 2\text{ k}\Omega$, $C_L = 100\text{ pF}$, $A_v = +1$)	5	7		V/ μs
GBP	Gain bandwidth product ($f = 100\text{ kHz}$, $R_L = 2\text{ k}\Omega$, $C_L = 100\text{ pF}$)	10	15		MHz
B	Unity gain bandwidth (open loop)		9		MHz

**Table 3. Electrical characteristics at $V_{CC+} = 15\text{ V}$, $V_{CC-} = -15\text{ V}$, $T_{amb} = 25\text{ °C}$
(unless otherwise specified) (continued)**

Symbol	Parameter	Min.	Typ.	Max.	Unit
A_m	Gain margin ($R_L = 2\text{ k}\Omega$) $C_L = 0\text{ pF}$ $C_L = 100\text{ pF}$		-11 -6		dB
\varnothing_m	Phase margin $C_L = 0\text{ pF}$ $C_L = 100\text{ pF}$		55 30		Degrees
e_n	Equivalent input noise voltage ($R_s = 100\ \Omega$, $f = 1\text{ kHz}$)		4.5		$\frac{nV}{\sqrt{Hz}}$
i_n	Equivalent input noise current ($f = 1\text{ kHz}$)		0.5		$\frac{\mu A}{\sqrt{Hz}}$
THD	Total harmonic distortion $R_L = 2\text{ k}\Omega$, $f = 20\text{ Hz to } 20\text{ kHz}$, $V_o = 3\ V_{rms}$, $A_v = +1$		0.002		%
V_{o1}/V_{o2}	Channel separation ($f = 20\text{ Hz to } 20\text{ kHz}$)		120		dB
FPB	Full power bandwidth ($V_o = 27\ V_{pp}$, $R_L = 2\text{ k}\Omega$, $THD \leq 1\%$)		120		kHz
Z_o	Output impedance ($V_o = 0\text{ V}$, $f = 9\text{ MHz}$)		37		Ω
R_i	Input resistance ($V_{ic} = 0\text{ V}$)		175		k Ω
C_i	Input capacitance ($V_{ic} = 0\text{ V}$)		12		pF

Figure 2. Total supply current vs. supply voltage

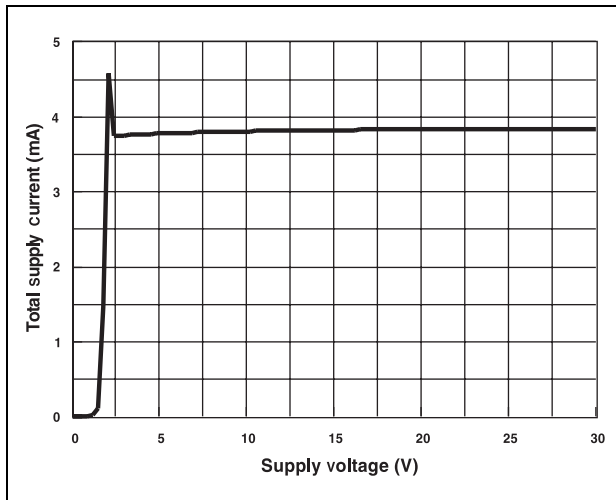

Figure 3. Output short-circuit current vs. output voltage

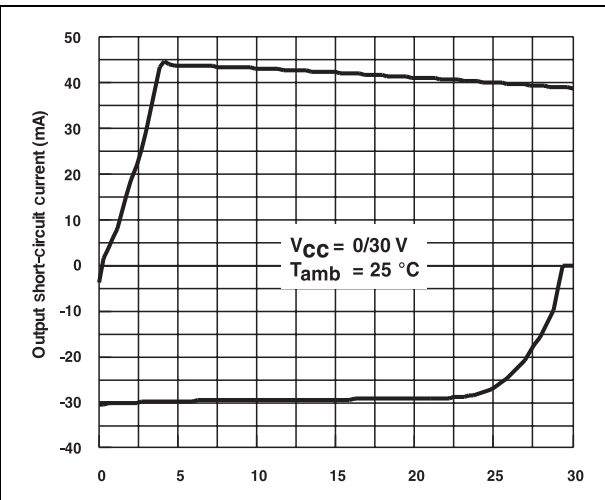

Figure 4. Output voltage vs. supply voltage ($V_{id} = \pm 1\text{ V}$, $R_L = 600\ \Omega$)

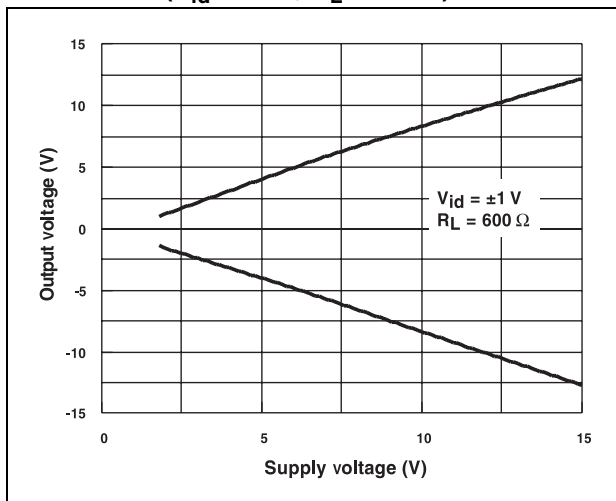

Figure 5. Output voltage vs. supply voltage ($V_{id} = \pm 1\text{ V}$, $R_L = 2\text{ k}\Omega$)

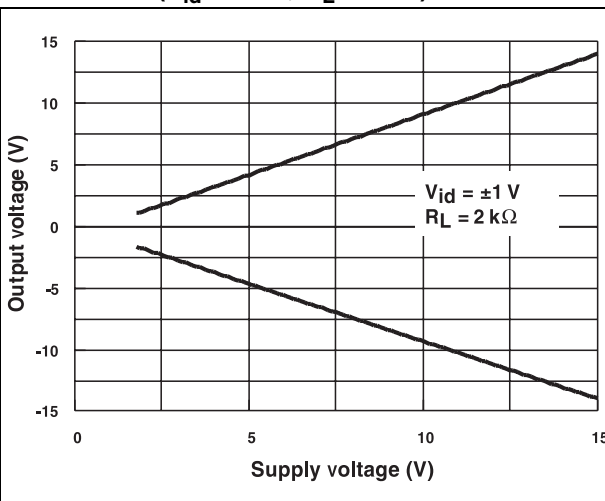

Figure 6. Equivalent input noise voltage vs. frequency

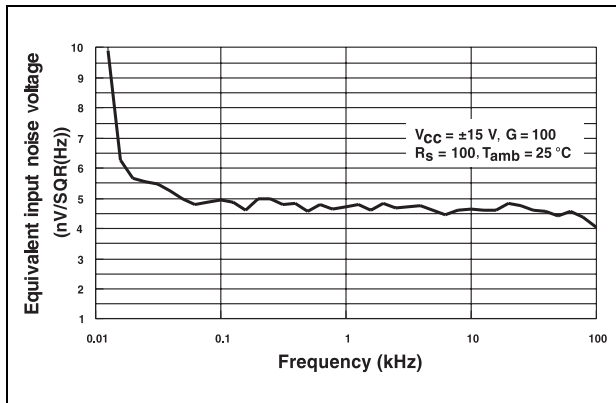

Figure 7. THD + noise vs. frequency

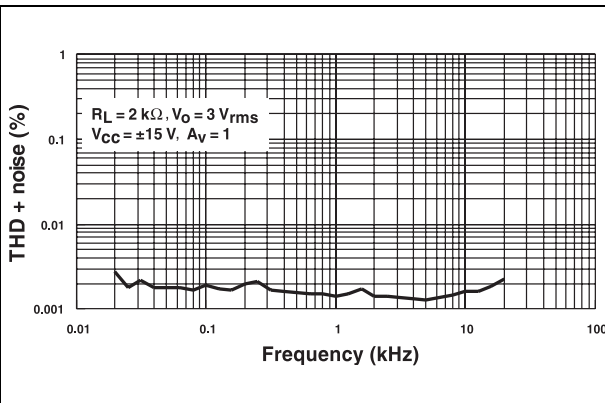

Figure 8. Voltage gain and phase vs. frequency

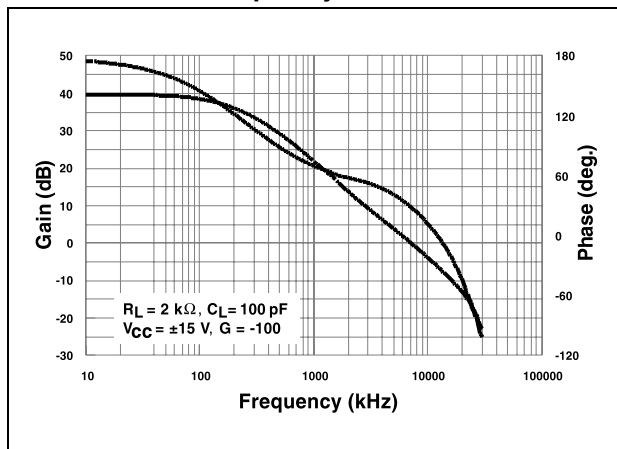
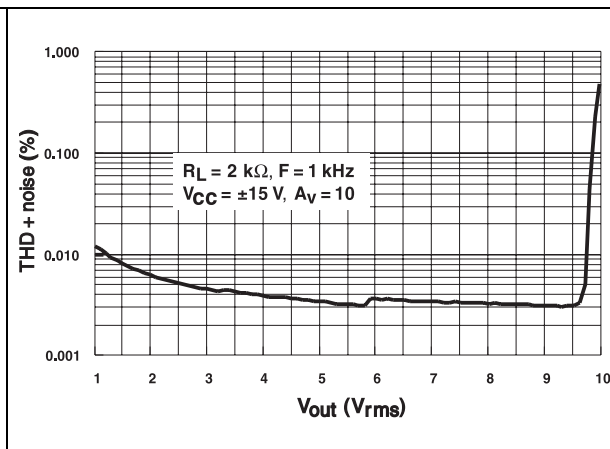

Figure 9. THD + noise vs. V_{out}



4 Package information

In order to meet environmental requirements, ST offers these devices in different grades of ECOPACK® packages, depending on their level of environmental compliance. ECOPACK specifications, grade definitions and product status are available at: www.st.com. ECOPACK is an ST trademark.

Figure 10. DIP8 package outline

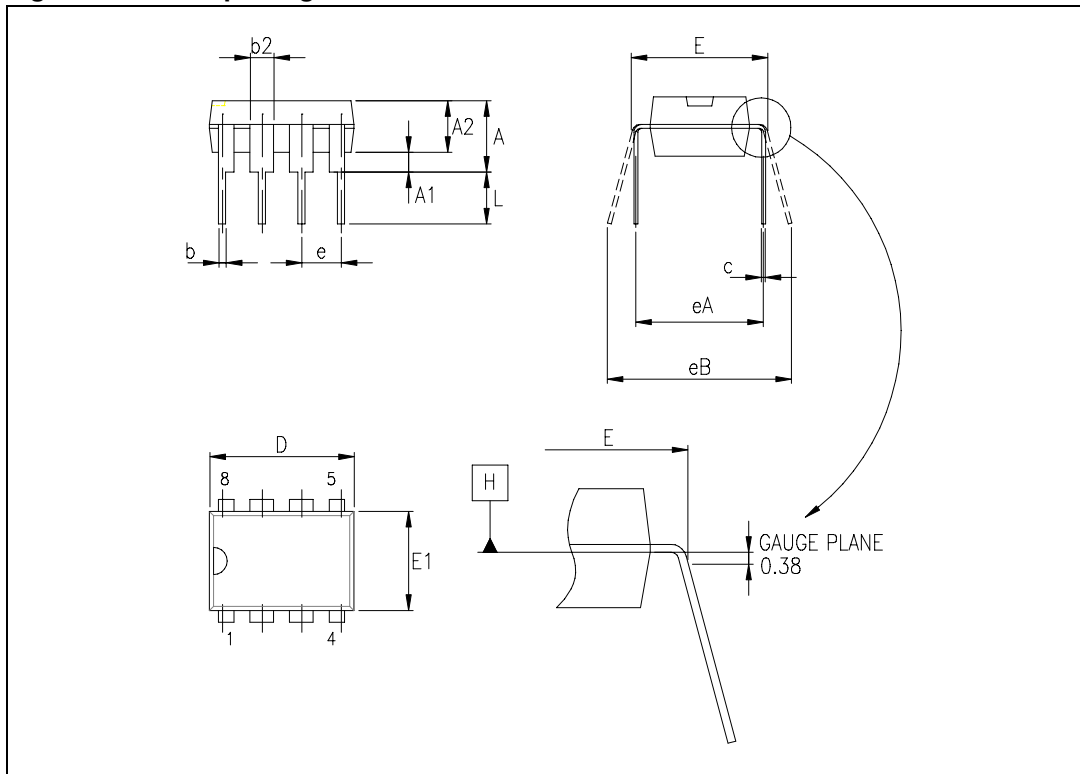

Table 4. DIP8 package mechanical data

Symbol	Dimensions					
	Millimeters			Inches		
	Min.	Typ.	Max.	Min.	Typ.	Max.
A		3.32			0.131	
a1	0.51			0.020		
B	1.15		1.65	0.045		0.065
b	0.356		0.55	0.014		0.022
b1	0.204		0.304	0.008		0.012
D			10.92			0.430
E	7.95		9.75	0.313		0.384
e		2.54			0.100	
e3		7.62			0.300	
e4		7.62			0.300	
F			6.6			0.260
i			5.08			0.200
L	3.18		3.81	0.125		0.150
Z			1.52			0.060

Figure 11. SO-8 package outline

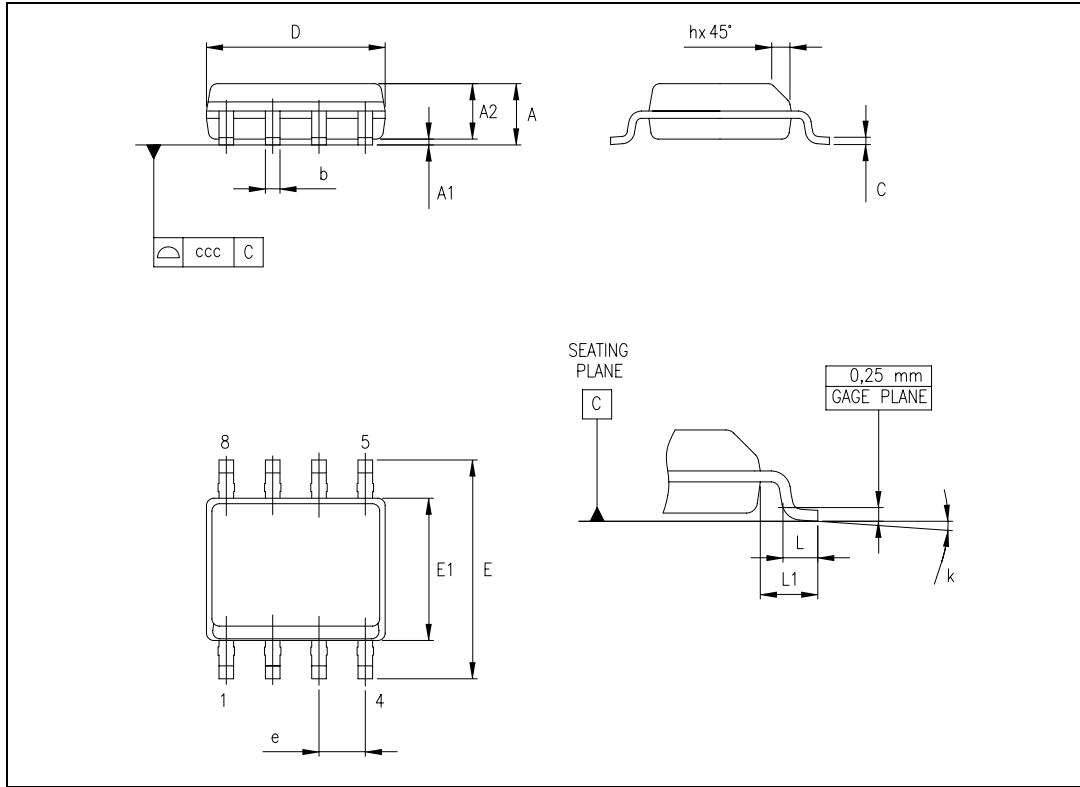

Table 5. SO-8 package mechanical data

Symbol	Dimensions					
	Millimeters			Inches		
	Min.	Typ.	Max.	Min.	Typ.	Max.
A			1.75			0.069
A1	0.10		0.25	0.004		0.010
A2	1.25			0.049		
b	0.28		0.48	0.011		0.019
c	0.17		0.23	0.007		0.010
D	4.80	4.90	5.00	0.189	0.193	0.197
E	5.80	6.00	6.20	0.228	0.236	0.244
E1	3.80	3.90	4.00	0.150	0.154	0.157
e		1.27			0.050	
h	0.25		0.50	0.010		0.020
L	0.40		1.27	0.016		0.050
L1		1.04			0.040	
k	1°		8°	1°		8°
ccc			0.10			0.004

5 Ordering information

Table 6. Order codes

Order code	Temperature range	Package	Packing	Marking
TS522ID/DT	-40 to +125 °C	SO-8	Tube/tape and reel	522I
TS522IN	-40 to +125 °C	DIP8	Tube	TS522IN
TS522IYDT ⁽¹⁾	-40 to +125 °C	SO-8 (automotive grade)	Tube/tape and reel	522IY

1. Qualified and characterized according to AEC Q100 and Q003 or equivalent, advanced screening according to AEC Q001 and Q 002 or equivalent.

6 Revision history

Table 7. Document revision history

Date	Revision	Changes
01-Nov-2001	1	Initial release.
14-Oct-2008	2	Document reformatted. Added automotive grade order codes in Table 6: Order codes . Removed macromodel.
12-Sep-2012	3	Updated Features (removed "Macromodel"). Removed TS522IYD order code from Table 6 . Updated ECOPACK text in Section 4 . Minor corrections throughout document.

Please Read Carefully:

Information in this document is provided solely in connection with ST products. STMicroelectronics NV and its subsidiaries ("ST") reserve the right to make changes, corrections, modifications or improvements, to this document, and the products and services described herein at any time, without notice.

All ST products are sold pursuant to ST's terms and conditions of sale.

Purchasers are solely responsible for the choice, selection and use of the ST products and services described herein, and ST assumes no liability whatsoever relating to the choice, selection or use of the ST products and services described herein.

No license, express or implied, by estoppel or otherwise, to any intellectual property rights is granted under this document. If any part of this document refers to any third party products or services it shall not be deemed a license grant by ST for the use of such third party products or services, or any intellectual property contained therein or considered as a warranty covering the use in any manner whatsoever of such third party products or services or any intellectual property contained therein.

UNLESS OTHERWISE SET FORTH IN ST'S TERMS AND CONDITIONS OF SALE ST DISCLAIMS ANY EXPRESS OR IMPLIED WARRANTY WITH RESPECT TO THE USE AND/OR SALE OF ST PRODUCTS INCLUDING WITHOUT LIMITATION IMPLIED WARRANTIES OF MERCHANTABILITY, FITNESS FOR A PARTICULAR PURPOSE (AND THEIR EQUIVALENTS UNDER THE LAWS OF ANY JURISDICTION), OR INFRINGEMENT OF ANY PATENT, COPYRIGHT OR OTHER INTELLECTUAL PROPERTY RIGHT.

UNLESS EXPRESSLY APPROVED IN WRITING BY TWO AUTHORIZED ST REPRESENTATIVES, ST PRODUCTS ARE NOT RECOMMENDED, AUTHORIZED OR WARRANTED FOR USE IN MILITARY, AIR CRAFT, SPACE, LIFE SAVING, OR LIFE SUSTAINING APPLICATIONS, NOR IN PRODUCTS OR SYSTEMS WHERE FAILURE OR MALFUNCTION MAY RESULT IN PERSONAL INJURY, DEATH, OR SEVERE PROPERTY OR ENVIRONMENTAL DAMAGE. ST PRODUCTS WHICH ARE NOT SPECIFIED AS "AUTOMOTIVE GRADE" MAY ONLY BE USED IN AUTOMOTIVE APPLICATIONS AT USER'S OWN RISK.

Resale of ST products with provisions different from the statements and/or technical features set forth in this document shall immediately void any warranty granted by ST for the ST product or service described herein and shall not create or extend in any manner whatsoever, any liability of ST.

ST and the ST logo are trademarks or registered trademarks of ST in various countries.

Information in this document supersedes and replaces all information previously supplied.

The ST logo is a registered trademark of STMicroelectronics. All other names are the property of their respective owners.

© 2012 STMicroelectronics - All rights reserved

STMicroelectronics group of companies

Australia - Belgium - Brazil - Canada - China - Czech Republic - Finland - France - Germany - Hong Kong - India - Israel - Italy - Japan - Malaysia - Malta - Morocco - Philippines - Singapore - Spain - Sweden - Switzerland - United Kingdom - United States of America

www.st.com

X-ON Electronics

Largest Supplier of Electrical and Electronic Components

Click to view similar products for [Operational Amplifiers - Op Amps](#) category:

Click to view products by [STMicroelectronics](#) manufacturer:

Other Similar products are found below :

[OPA2991IDSGR](#) [OPA607IDCKT](#) [007614D](#) [633773R](#) [635798C](#) [635801A](#) [702115D](#) [709228FB](#) [741528D](#) [NCV33072ADR2G](#)
[SC2902DTBR2G](#) [SC2903DR2G](#) [SC2903VDR2G](#) [LM258AYDT](#) [LM358SNG](#) [430227FB](#) [430228DB](#) [460932C](#) [AZV831KTR-G1](#) [409256CB](#)
[430232AB](#) [LM2904DR2GH](#) [LM358YDT](#) [LT1678IS8](#) [042225DB](#) [058184EB](#) [070530X](#) [SC224DR2G](#) [SC239DR2G](#) [SC2902DG](#)
[SCYA5230DR2G](#) [714228XB](#) [714846BB](#) [873836HB](#) [MIC918YC5-TR](#) [TS912BIYDT](#) [NCS2004MUTAG](#) [NCV33202DMR2G](#)
[M38510/13101BPA](#) [NTE925](#) [SC2904DR2G](#) [SC358DR2G](#) [LM358EDR2G](#) [AZV358MTR-G1](#) [AP4310AUMTR-AG1](#) [HA1630D02MMEL-E](#)
[NJM358CG-TE2](#) [HA1630S01LPEL-E](#) [LM324AWPT](#) [HA1630Q06TELL-E](#)