

Input/output rail-to-rail low-power operational amplifiers

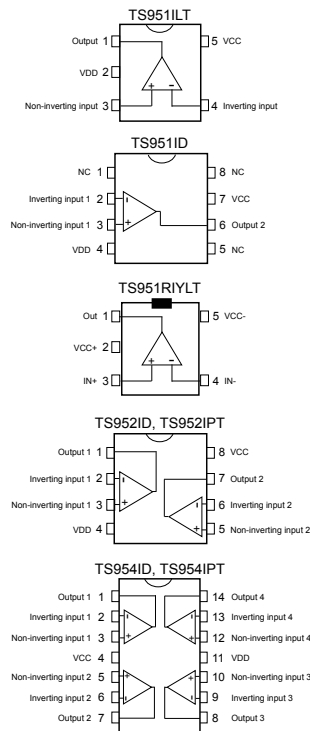

Product status link

[TS951, TS952, TS954](#)

Features

- Rail-to-rail input common mode voltage range
- Rail-to-rail output voltage swing
- Operates from 2.7 V to 12 V
- High-speed (3 MHz, 1 V/μs)
- Low consumption (0.9 mA at 3 V)
- Supply voltage rejection ratio: 80 dB
- Latch-up immunity
- Available in SOT23-5 micropackage, SO8, TSSOP8, SO14, and TSSOP14 packages

Applications

- Industrial and automotive signal conditioning
- Active filtering
- Medical instrumentation
- Digital-to-analog converter buffers
- Portable headphone speaker drivers

Description

The **TS951**, **TS952** and **TS954** family of devices are rail-to-rail BiCMOS operational amplifiers optimized and fully specified for 3 V and 5 V operation.

The **TS951** device is housed in the space-saving 5-pin SOT23 package that makes it well suited for battery powered systems. This micropackage simplifies the PC board design because of its ability to be placed in tight spaces (outside dimensions are: 2.8 mm x 2.9 mm).

1 Absolute maximum ratings and operating conditions

Table 1. Absolute maximum ratings

Symbol	Parameter		Value	Unit	
V_{CC}	Supply voltage ⁽¹⁾		14	V	
V_{id}	Differential input voltage ⁽²⁾		± 1		
V_{in}	Input voltage ⁽³⁾		$V_{DD} - 0.3$ to $V_{CC} + 0.3$		
T_{stg}	Storage temperature range		-65 to 150	°C	
T_j	Maximum junction temperature		150		
R_{thja}	Thermal resistance junction-to-ambient ⁽⁴⁾	SOT23-5	250	°C/W	
		SO8	125		
		TSSOP8	120		
		SO14	103		
		TSSOP14	100		
R_{thjc}	Thermal resistance junction-to-case ⁽⁴⁾	SOT23-5	81		
		SO8	40		
		TSSOP8	37		
		SO14	31		
		TSSOP14	32		
ESD	HBM: human body model ⁽⁵⁾	TS951	1	kV	
		TS952	2		
		TS954	3		
	CDM: charged device model ⁽⁷⁾	MM: machine model ⁽⁶⁾		120	V
			TS951	1.5	kV
			TS952	1.5	
TS954	1				
	Latch-up immunity		200	mA	
	Lead temperature (soldering, 10 s)		260	°C	

1. All voltage values, except differential voltage are with respect to network ground terminal.
2. Differential voltages are the non-inverting input terminal with respect to the inverting input terminal. If $V_{id} > \pm 1$ V, the maximum input current must not exceed ± 1 mA. In this case ($V_{id} > \pm 1$ V), an input series resistor must be added to limit input current.
3. Do not exceed 14 V.
4. Short-circuits can cause excessive heating and destructive dissipation. R_{th} are typical values.
5. Human body model: a 100 pF capacitor is charged to the specified voltage, then discharged through a 1.5 k Ω resistor between two pins of the device. This is done for all couples of connected pin combinations while the other pins are floating.
6. Machine model: a 200 pF capacitor is charged to the specified voltage, then discharged directly between two pins of the device with no external series resistor (internal resistor < 5 Ω). This is done for all couples of connected pin combinations while the other pins are floating.
7. Charged device model: all pins and the package are charged together to the specified voltage and then discharged directly to ground through only one pin. This is done for all pins.

Table 2. Operating conditions

Symbol	Parameter	Value	Unit
V_{CC}	Supply voltage	2.7 to 12	V
V_{icm}	Common mode input voltage range	$V_{DD} - 0.2$ to $V_{CC} + 0.2$	
T_{oper}	Operating free air temperature range	-40 to 125	°C

2 Electrical characteristics

Table 3. Electrical characteristics at $V_{CC} = 3\text{ V}$, $V_{DD} = 0\text{ V}$, R_L connected to $V_{CC}/2$, $T_{amb} = 25\text{ °C}$ (unless otherwise specified)

Symbol	Parameter	Min.	Typ.	Max.	Unit
V_{io}	Input offset voltage			6	mV
	$T_{min} \leq T_{amb} \leq T_{max}$			8	
$\Delta V_{io}/\Delta T$	Input offset voltage drift		2		$\mu\text{V}/\text{°C}$
I_{io}	Input offset current		1	30	nA
		$T_{min} \leq T_{amb} \leq T_{max}$		80	
I_{ib}	Input bias current	$V_{icm} = V_{CC}/2$	35	100	
		$T_{min} \leq T_{amb} \leq T_{max}$		200	
CMR	Common mode rejection ratio	50	80		dB
SVR	Supply voltage rejection ratio, $V_{CC} = 2.7\text{ V}$ to 3.3 V	60	80		
A_{vd}	Large signal voltage gain, $V_o = 2\text{ V}_{pk-pk}$, $R_L = 600\ \Omega$		80		
V_{OH}	High level output voltage, $R_L = 600\ \Omega$	2.8	2.9		V
V_{OL}	Low level output voltage, $R_L = 600\ \Omega$		80	250	mV
I_{sc}	Output short-circuit current	10			mA
I_{CC}	Supply current (per amplifier), no load, $V_{icm} = V_{CC}/2$		0.9	1.3	
GBP	Gain bandwidth product, $R_L = 2\text{ k}\Omega$		3		MHz
SR	Slew rate		1		V/ μs
ϕ_m	Phase margin at unit gain, $R_L = 600\ \Omega$, $C_L = 100\text{ pF}$		60		Degrees
Gm	Gain margin, $R_L = 600\ \Omega$, $C_L = 100\text{ pF}$		10		dB
e_n	Equivalent input noise voltage, $f = 1\text{ kHz}$		25		nV / $\sqrt{\text{Hz}}$
THD	Total harmonic distortion, $V_{out} = 4\text{ V}_{pk-pk}$, $F = 10\text{ kHz}$, $A_v = 2$, $R_L = 10\text{ k}\Omega$		0.01		%

Table 4. Electrical characteristics at $V_{CC} = 5\text{ V}$, $V_{DD} = 0\text{ V}$, R_L connected to $V_{CC}/2$, $T_{amb} = 25\text{ }^\circ\text{C}$ (unless otherwise specified)

Symbol	Parameter	Min.	Typ.	Max.	Unit
V_{io}	Input offset voltage			6	mV
	$T_{min} \leq T_{amb} \leq T_{max}$			8	
$\Delta V_{io}/\Delta T$	Input offset voltage drift		2		$\mu\text{V}/^\circ\text{C}$
I_{io}	Input offset current	$V_{icm} = V_{CC}/2$	1	30	nA
		$T_{min} \leq T_{amb} \leq T_{max}$		80	
I_{ib}	Input bias current	$V_{icm} = V_{CC}/2$	35	100	
		$T_{min} \leq T_{amb} \leq T_{max}$		200	
CMR	Common mode rejection ratio	50	80		dB
SVR	Supply voltage rejection ratio, $V_{CC} = 2.7\text{ V}$ to 3.3 V	60	80		
A_{vd}	Large signal voltage gain, $V_o = 2 V_{pk-pk}$, $R_L = 600\ \Omega$		86		
V_{OH}	High level output voltage, $R_L = 600\ \Omega$	4.7	4.8		V
V_{OL}	Low level output voltage, $R_L = 600\ \Omega$		80	300	mV
I_{sc}	Output short-circuit current	10			mA
I_{CC}	Supply current (per amplifier), no load, $V_{icm} = V_{CC}/2$		0.95	1.4	
GBP	Gain bandwidth product, $R_L = 2\text{ k}\Omega$		3		MHz
SR	Slew rate		1		V/ μs
ϕ_m	Phase margin at unit gain, $R_L = 600\ \Omega$, $C_L = 100\text{ pF}$		60		Degrees
Gm	Gain margin, $R_L = 600\ \Omega$, $C_L = 100\text{ pF}$		10		dB
e_n	Equivalent input noise voltage, $f = 1\text{ kHz}$		25		nV / $\sqrt{\text{Hz}}$
THD	Total harmonic distortion, $V_{out} = 4 V_{pk-pk}$, $F = 10\text{ kHz}$, $A_V = 2$, $R_L = 10\text{ k}\Omega$		0.01		%

3 Electrical characteristic curves

Figure 1. Supply current vs. supply voltage

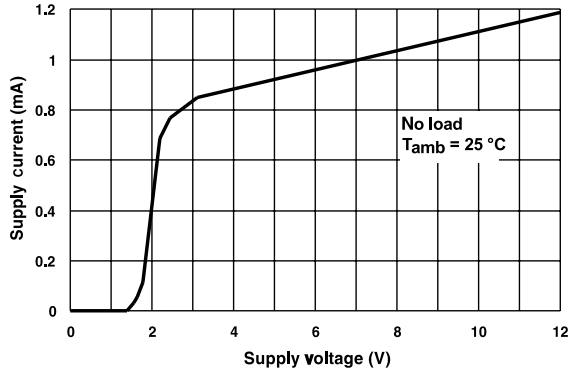

Figure 2. Output short-circuit current vs. output voltage

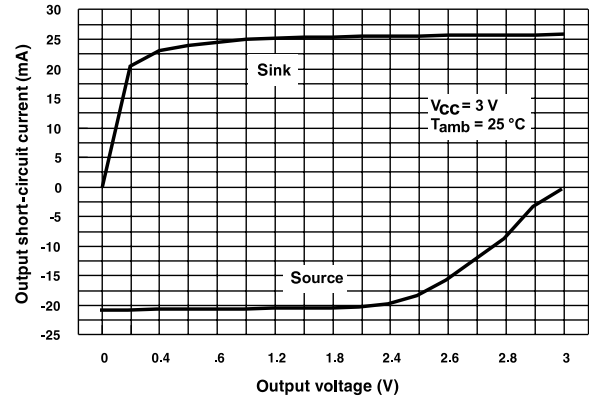

Figure 3. Voltage gain and phase vs. frequency

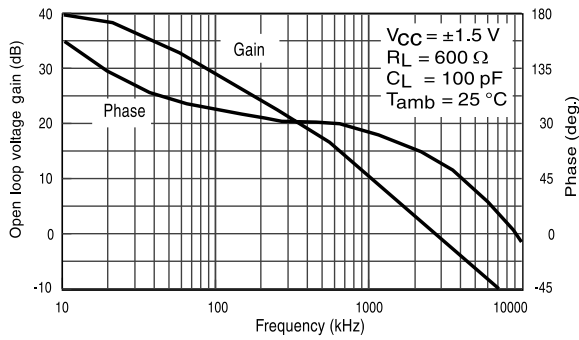

Figure 4. Supply current vs. temperature

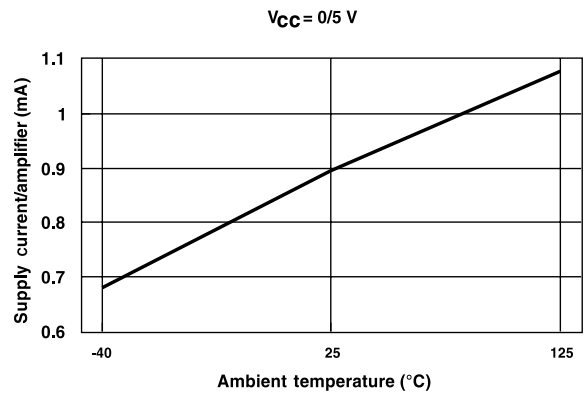

Figure 5. Output short-circuit current vs. temperature

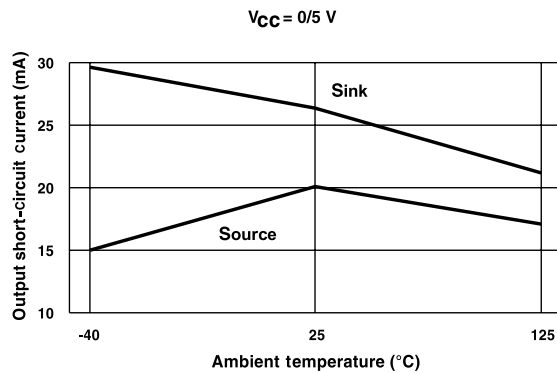

Figure 6. Slew rate vs. temperature

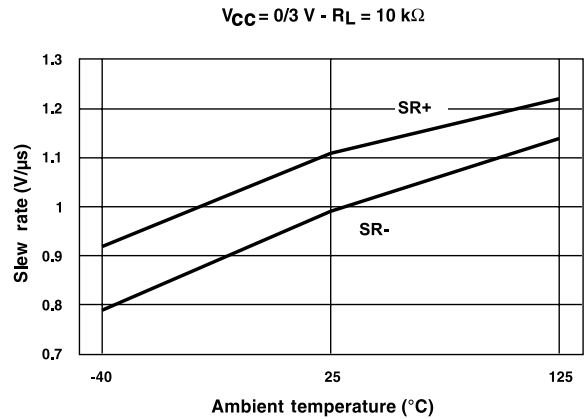

Figure 7. THD + noise vs. Vout (VCC = ± 1.5 V, RL = 600 Ω, f = 1 kHz, G = -1)

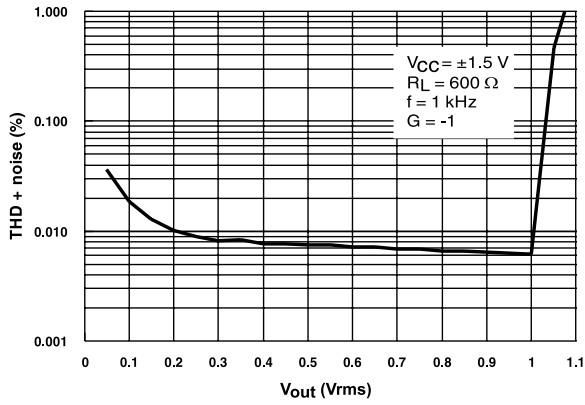

Figure 8. THD + noise vs. frequency

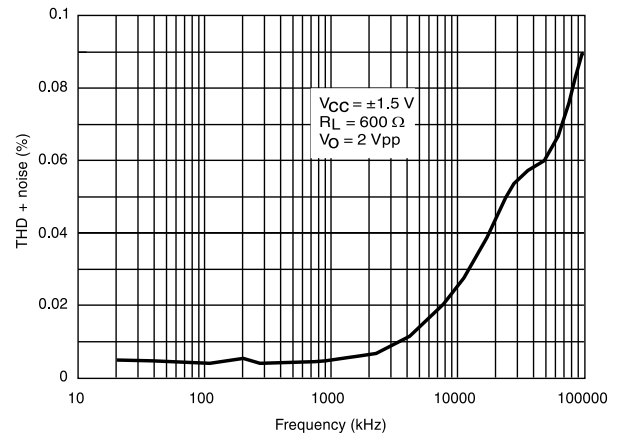

Figure 9. THD + noise vs. Vout (VCC = ± 1.5 V, RL = 2 kΩ, f = 1 kHz, G = -1)

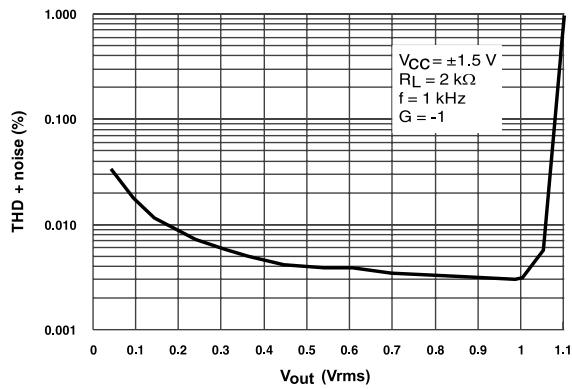
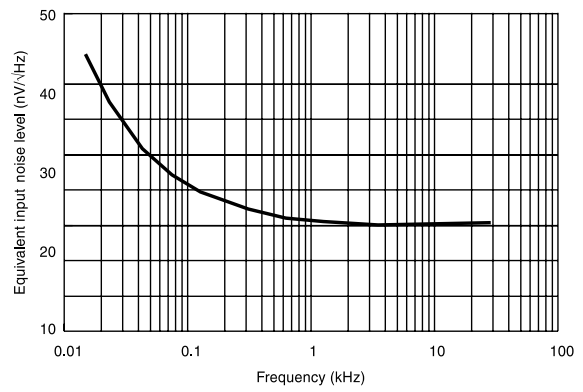

Figure 10. Equivalent input noise voltage vs. frequency



4 Package information

In order to meet environmental requirements, ST offers these devices in different grades of **ECOPACK** packages, depending on their level of environmental compliance. ECOPACK specifications, grade definitions and product status are available at: www.st.com. ECOPACK is an ST trademark.

4.1 SOT23-5 package information

Figure 11. SOT23-5 package outline

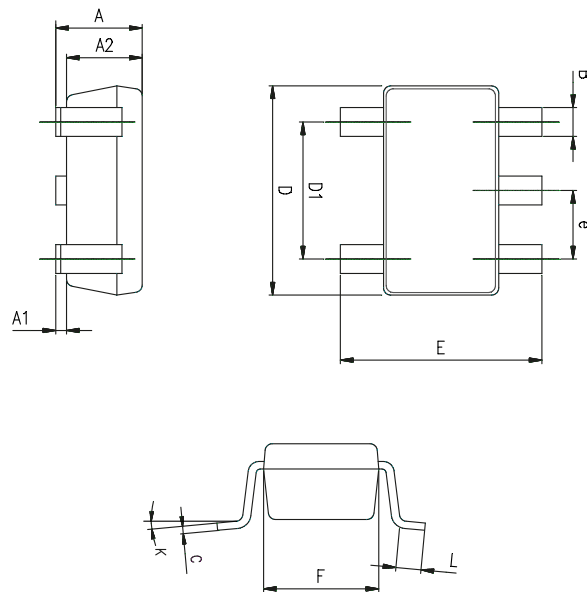

Table 5. SOT23-5 mechanical data

Ref.	Dimensions					
	Millimeters			Inches		
	Min.	Typ.	Max.	Min.	Typ.	Max.
A	0.90	1.20	1.45	0.035	0.047	0.057
A1			0.15			0.006
A2	0.90	1.05	1.30	0.035	0.041	0.051
B	0.35	0.40	0.50	0.014	0.016	0.020
C	0.09	0.15	0.20	0.004	0.006	0.008
D	2.80	2.90	3.00	0.110	0.114	0.118
D1		1.90			0.075	
e		0.95			0.037	
E	2.60	2.80	3.00	0.102	0.110	0.118
F	1.50	1.60	1.75	0.059	0.063	0.069
L	0.10	0.35	0.60	0.004	0.014	0.024
K	0 degrees		10 degrees	0 degrees		10 degrees

4.2 SO8 package information

Figure 12. SO8 package outline

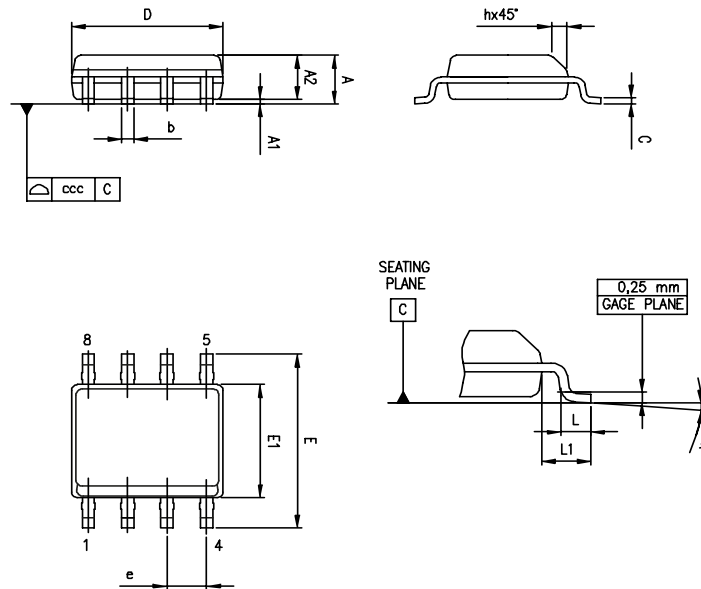
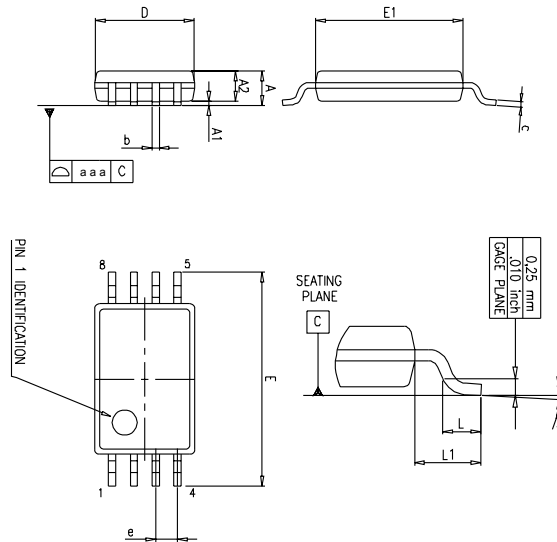

Table 6. SO8 package mechanical data

Ref.	Dimensions					
	Millimeters			Inches		
	Min.	Typ.	Max.	Min.	Typ.	Max.
A			1.75			0.069
A1	0.10		0.25	0.004		0.010
A2	1.25			0.049		
b	0.28		0.48	0.011		0.019
c	0.17		0.23	0.007		0.010
D	4.80	4.90	5.00	0.189	0.193	0.197
E	5.80	6.00	6.20	0.228	0.236	0.244
E1	3.80	3.90	4.00	0.150	0.154	0.157
e		1.27			0.050	
h	0.25		0.50	0.010		0.020
L	0.40		1.27	0.016		0.050
L1		1.04			0.040	
k	0°		8°	0°		8°
ccc			0.10			0.004

4.3 TSSOP8 package information

Figure 13. TSSOP8 package outline

Table 7. TSSOP8 package mechanical data

Ref.	Dimensions					
	Millimeters			Inches		
	Min.	Typ.	Max.	Min.	Typ.	Max.
A			1.20			0.047
A1	0.05		0.15	0.002		0.006
A2	0.80	1.00	1.05	0.031	0.039	0.041
b	0.19		0.30	0.007		0.012
c	0.09		0.20	0.004		0.008
D	2.90	3.00	3.10	0.114	0.118	0.122
E	6.20	6.40	6.60	0.244	0.252	0.260
E1	4.30	4.40	4.50	0.169	0.173	0.177
e		0.65			0.0256	
k	0°		8°	0°		8°
L	0.45	0.60	0.75	0.018	0.024	0.030
L1		1			0.039	
aaa			0.10			0.004

4.4 SO14 package information

Figure 14. SO14 package outline

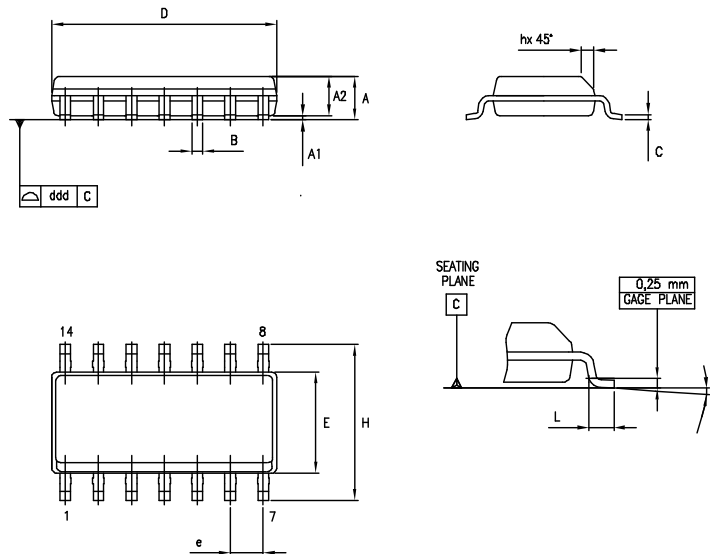

Table 8. SO14 package mechanical data

Ref.	Dimensions					
	Millimeters			Inches		
	Min.	Typ.	Max.	Min.	Typ.	Max.
			1.75			0.069
A	1.35		1.75	0.05		0.068
A1	0.10		0.25	0.004		0.009
A2	1.10		1.65	0.04		0.06
B	0.33		0.51	0.01		0.02
C	0.19		0.25	0.007		0.009
D	8.55		8.75	0.33		0.34
E	3.80		4.0	0.15		0.15
e		1.27			0.05	
H	5.80		6.20	0.22		0.24
h	0.25		0.50	0.009		0.02
L	0.40		1.27	0.015		0.05
k	8° (max.)					
ddd			0.10			0.004

4.5 TSSOP14 package information

Figure 15. TSSOP14 package outline

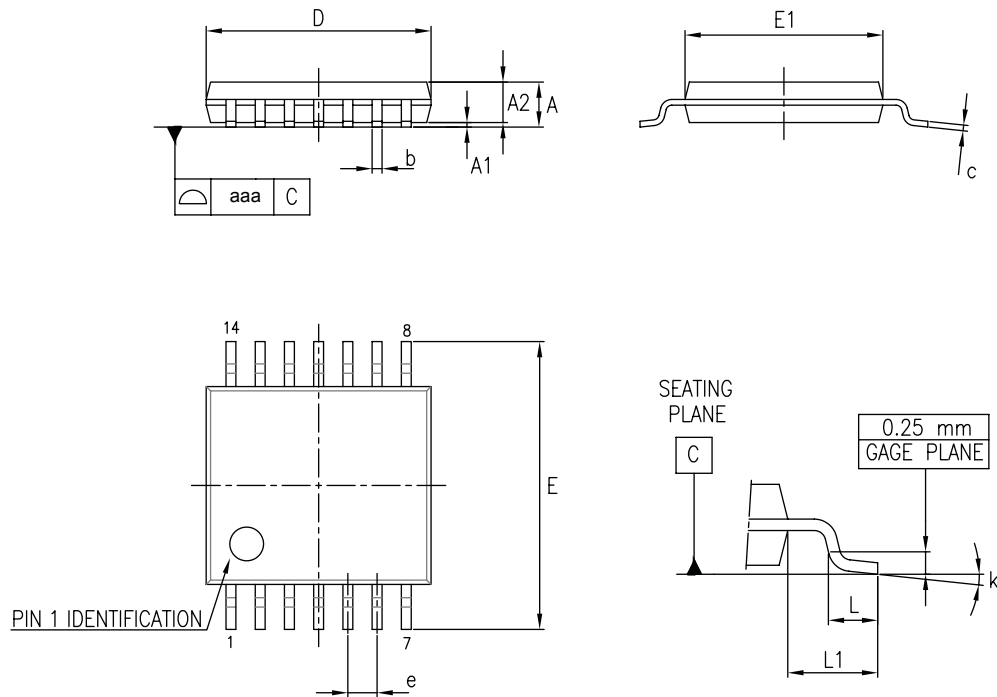

Table 9. TSSOP14 package mechanical data

Ref.	Dimensions					
	Millimeters			Inches		
	Min.	Typ.	Max.	Min.	Typ.	Max.
A			1.20			0.047
A1	0.05		0.15	0.002	0.004	0.006
A2	0.80	1.00	1.05	0.031	0.039	0.041
b	0.19		0.30	0.007		0.012
c	0.09		0.20	0.004		0.0089
D	4.90	5.00	5.10	0.193	0.197	0.201
E	6.20	6.40	6.60	0.244	0.252	0.260
E1	4.30	4.40	4.50	0.169	0.173	0.176
e		0.65			0.0256	
L	0.45	0.60	0.75	0.018	0.024	0.030
L1		1.00			0.039	
k	0°		8°	0°		8°
aaa			0.10			0.004

5 Ordering information

Table 10. Order codes

Order code	Temperature range	Package	Packaging	Marking
TS951IDT	-40 °C to 125 °C	SO8	Tape and reel	951I
TS951ILT		SOT23-5		K101
TS951IYLT ⁽¹⁾		SOT23-5		K102
TS951RIYLT		(automotive grade)		K103
TS952IDT		SO8		952I
TS952IYDT ⁽¹⁾		SO8 (automotive grade)		952IY
TS952IPT		TSSOP8		952I
TS952IYPT ⁽¹⁾		TSSOP8 (automotive grade)		952Y
TS954IDT		SO14		954I
TS954IYDT ⁽¹⁾		SO14 (automotive grade)		954IY
TS954IPT		TSSOP14		954I
TS954IYPT ⁽¹⁾		TSSOP14 (automotive grade)		954IY

1. Qualified and characterized according to AEC Q100 and Q003 or equivalent, advanced screening according to AEC Q001 and Q002 or equivalent.

Revision history

Table 11. Document revision history

Date	Revision	Changes
01-May-2001	1	Initial release.
02-Jan-2005	2	Modifications on AMR Table 1: "Absolute maximum ratings" (explanation of Vid and Vi limits, ESD MM and CDM values added, Rthja added).
03-Jul-2005	3	PPAP references inserted in the datasheet see Table 10: "Order codes".
04-Aug-2005	4	Table data was badly formatted, see Table 4.
15-Dec-2005	5	TS951IYLT PPAP reference added, see Table 10: "Order codes".
10-Dec-2007	6	Added missing order codes, and automotive grade status in Table 10: "Order codes". Updated footnotes for ESD parameters in Table 1: "Absolute maximum ratings". Reformatted package information.
10-Mar-2009	7	Removed TS951IN and TS951IYD/DT from Table 10: "Order codes".
24-Feb-2011	8	Changed TS951IYLT marking and updated automotive grade status in in Table 10: "Order codes".
21-Nov-2012	9	Updated Features (added DIP8, SO-8, TSSOP8, DIP14, SO-14, and TSSOP14 packages). Updated Table 1: "Absolute maximum ratings" (added values of DIP8 and DIP14 packages for R _{thja} and R _{thjc} symbols). Updated title of Figure 7 and Figure 9 (added conditions). <i>Note that these figures were subsequently removed in revision 10 below.</i> Updated Table 10: "Order codes" (removed TS952IYD and TS954IYD order codes, qualified status of TS954IYPT and TS952IYPT order codes). Minor corrections throughout document.
11-Sep-2013	10	Removed DIP8 and DIP14 packages and all information pertaining to them. Table 10: "Order codes"; updated marking of order code TS951IYLT from K1A2 to K102.
27-Jun-2014	11	Updated ESD(MM) in Table 1: "Absolute maximum ratings" Updated Table 10: "Order codes"
13-Mar-2015	12	Added order code TS951RIYLT throughout document
16-Oct-2019	13	Updated applications in cover page and Table 10. Order codes .

IMPORTANT NOTICE – PLEASE READ CAREFULLY

STMicroelectronics NV and its subsidiaries (“ST”) reserve the right to make changes, corrections, enhancements, modifications, and improvements to ST products and/or to this document at any time without notice. Purchasers should obtain the latest relevant information on ST products before placing orders. ST products are sold pursuant to ST’s terms and conditions of sale in place at the time of order acknowledgement.

Purchasers are solely responsible for the choice, selection, and use of ST products and ST assumes no liability for application assistance or the design of Purchasers’ products.

No license, express or implied, to any intellectual property right is granted by ST herein.

Resale of ST products with provisions different from the information set forth herein shall void any warranty granted by ST for such product.

ST and the ST logo are trademarks of ST. For additional information about ST trademarks, please refer to www.st.com/trademarks. All other product or service names are the property of their respective owners.

Information in this document supersedes and replaces information previously supplied in any prior versions of this document.

© 2019 STMicroelectronics – All rights reserved

X-ON Electronics

Largest Supplier of Electrical and Electronic Components

Click to view similar products for [Operational Amplifiers - Op Amps](#) category:

Click to view products by [STMicroelectronics](#) manufacturer:

Other Similar products are found below :

[NCV33072ADR2G](#) [LM358SNG](#) [430227FB](#) [UPC824G2-A](#) [LT1678IS8](#) [042225DB](#) [058184EB](#) [UPC822G2-A](#) [UPC259G2-A](#) [UPC258G2-A](#)
[NCV33202DMR2G](#) [NTE925](#) [AZV358MTR-G1](#) [AP4310AUMTR-AG1](#) [HA1630D02MMEL-E](#) [HA1630S01LPEL-E](#) [SCY33178DR2G](#)
[NJU77806F3-TE1](#) [NCV5652MUTWG](#) [NCV20034DR2G](#) [LM324EDR2G](#) [LM2902EDR2G](#) [NTE7155](#) [NTE778S](#) [NTE871](#) [NTE924](#) [NTE937](#)
[MCP6V17T-E/MNY](#) [MCP6V19-E/ST](#) [MXD8011HF](#) [MCP6V17T-E/MS](#) [SCY6358ADR2G](#) [ADA4523-1BCPZ](#) [LTC2065HUD#PBF](#)
[ADA4523-1BCPZ-RL7](#) [2SD965T-R](#) [RS6332PXK](#) [BDM8551](#) [BDM321](#) [MD1324](#) [COS8052SR](#) [COS8552SR](#) [COS8554SR](#) [COS2177SR](#)
[COS2353SR](#) [COS724TR](#) [ASOPD4580S-R](#) [RS321BKXF](#) [ADA4097-1HUIJZ-RL7](#) [NCS20282FCTTAG](#)