



# TSH110-TSH111-TSH112-TSH113-TSH114

## Wide band low noise operational amplifiers

### Features

- Low noise:  $3\text{nV}/\sqrt{\text{Hz}}$
- Low supply current:  $3.2\text{mA}$
- $47\text{mA}$  output current
- Bandwidth:  $100\text{MHz}$
- $5\text{V}$  to  $12\text{V}$  supply voltage
- Slew rate:  $450\text{V}/\mu\text{s}$
- Specified for  $100\Omega$  load
- Very low distortion
- Tiny SOT23-5, TSSOP and SO packages

### Applications

- High-end video drivers
- Receiver for xDSL
- A/D converter driver
- High-end audio applications

### Description

The single TSH110 and TSH111, the dual TSH112, the triple TSH113 and the quad TSH114 are current feedback operational amplifiers featuring a very high slew rate of  $450\text{V}/\mu\text{s}$  and a large bandwidth of  $100\text{MHz}$ , with only a  $3.2\text{mA}$  quiescent supply current. The TSH111 and TSH113 feature a Standby function for each operator. This function is a power-down mode with a high output impedance.

These devices operate from  $\pm 2.5\text{V}$  to  $\pm 6\text{V}$  dual supply voltage or from  $5\text{V}$  to  $12\text{V}$  single supply voltage. They are able to drive a  $100\Omega$  load with a swing of  $9\text{V}$  minimum (for a  $12\text{V}$  power supply).

The harmonic and intermodulation distortions of these devices are very low, making this circuit a good choice for applications requiring wide bandwidth with multiple carriers.

For board space and weight saving, the TSH110 comes in miniature SOT23-5 package.

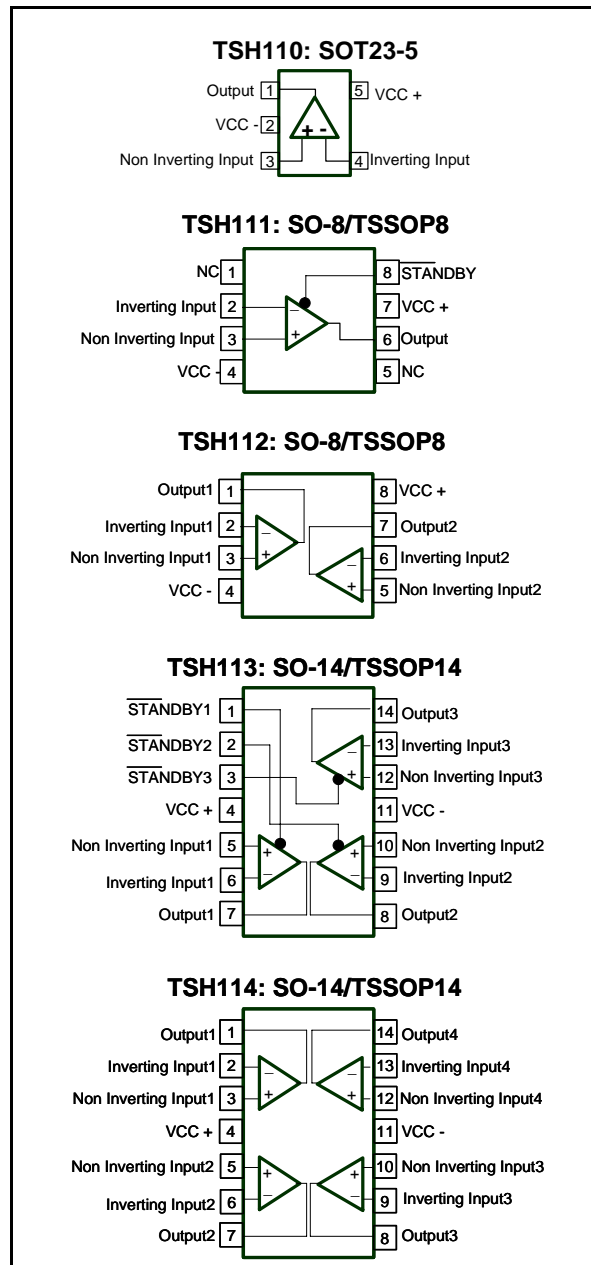

The TSH111 comes in SO-8 and TSSOP8 packages, the TSH112 comes in SO-8 and TSSOP8 packages, the TSH113 and TSH114 come in SO-14 and TSSOP14 packages.

# 1 Absolute maximum ratings and operating conditions

**Table 1. Absolute maximum ratings (AMR)**

Symbol	Parameter	Value	Unit
$V_{CC}$	Supply voltage <sup>(1)</sup>	14	V
$V_{id}$	Differential input voltage <sup>(2)</sup>	±1	V
$V_i$	Input voltage <sup>(3)</sup>	±6	V
$T_{oper}$	Operating free air temperature range	-40 to +85	°C
$T_{stg}$	Storage temperature	-65 to +150	°C
$T_j$	Maximum junction temperature	150	°C
$R_{thjc}$	Thermal resistance junction to case		
	SOT23-5	80	°C/W
	SO-8	28	
	SO-14	22	
	TSSOP8	37	
TSSOP14	32		
$R_{thja}$	Thermal resistance junction to ambient area		
	SOT23-5	250	°C/W
	SO-8	157	
	SO-14	125	
	TSSOP8	130	
TSSOP14	110		
ESD	HBM: human body model <sup>(4)</sup>	2.0	kV
	MM: machine model <sup>(5)</sup>	0.2	
	CDM: charged device model <sup>(6)</sup>	1.5	
	Output short circuit duration <sup>(7)</sup>		

1. All voltage values, except differential voltage, are with respect to network ground terminal.
2. Differential voltages are the non-inverting input terminal with respect to the inverting terminal.
3. The magnitude of input and output voltages must never exceed  $V_{CC} + 0.3V$
4. Human body model: A 100pF capacitor is charged to the specified voltage, then discharged through a 1.5kΩ resistor between two pins of the device. This is done for all couples of connected pin combinations while the other pins are floating.
5. Machine model: A 200pF capacitor is charged to the specified voltage, then discharged directly between two pins of the device with no external series resistor (internal resistor < 5Ω). This is done for all couples of connected pin combinations while the other pins are floating.
6. Charged device model: all pins and the package are charged together to the specified voltage and then discharged directly to the ground through only one pin. This is done for all pins.
7. Short-circuits can cause excessive heating and can result in destructive dissipation.

**Table 2. Operating conditions**

Symbol	Parameter	Value	Unit
$V_{CC}$	Supply voltage	5 to 12	V
$V_{icm}$	Common mode input voltage range	$V_{CC}^- + 1.5$ to $V_{CC}^+ - 1.5$	V

## 2 Electrical characteristics

**Table 3. Dual supply voltage,  $V_{CC} = \pm 2.5V$ ,  $R_{fb}^{(1)} = 680\Omega$ ,  $T_{amb} = 25^\circ C$  (unless otherwise specified)**

Symbol	Parameter	Test conditions	Min.	Typ.	Max.	Unit
<b>DC performance</b>						
$V_{io}$	Input offset voltage	$T_{amb}$	-1.5	0.3	2.0	mV
		$T_{min} < T_{amb} < T_{max}$		1		mV
$\Delta V_{io}$	Input offset voltage drift vs. temperature	$T_{min} < T_{amb} < T_{max}$		5		$\mu V/^\circ C$
$I_{ib+}$	Non inverting input bias current	$T_{amb}$	-10	1.4	13	$\mu A$
		$T_{min} < T_{amb} < T_{max}$		2.5		$\mu A$
$I_{ib-}$	Inverting input bias current	$T_{amb}$	-3	1.9	7	$\mu A$
		$T_{min} < T_{amb} < T_{max}$		2.5		$\mu A$
$R_{OL}$	Transimpedance	$R_L = 100\Omega$	500	750		$k\Omega$
$I_{CC}$	Supply current per operator	$T_{amb}$		3.2	4	mA
		$T_{min} < T_{amb} < T_{max}$		3.5		mA
CMR	Common mode rejection ratio ( $\Delta V_{ic}/\Delta V_{io}$ )		56	60		dB
SVR	Supply voltage rejection ratio ( $\Delta V_{CC}/\Delta V_{io}$ )		70	80		dB
PSR	Power supply rejection ratio ( $\Delta V_{CC}/\Delta V_{out}$ )	Gain=1, $R_{load}=3.9k\Omega$		48		dB
<b>Dynamic performance and output characteristics</b>						
$V_{oh}$	High level output voltage	$T_{amb}$ $R_L = 100\Omega$	1.4	2		V
		$T_{min} < T_{amb} < T_{max}$ $R_L = 100\Omega$ GND		1.9		V
$V_{ol}$	Low level output voltage	$T_{amb}$ $R_L = 100\Omega$		-1.8	-1.3	V
		$T_{min} < T_{amb} < T_{max}$ $R_L = 100\Omega$		-1.7		V
$ I_{sink} $	Output sink current	$T_{min} < T_{amb} < T_{max}$		20		mA
$I_{source}$	Output source current	$T_{min} < T_{amb} < T_{max}$		18		mA
BW	-3dB bandwidth	$V_{out}=1V_{pk}$ , $R_{fb}^{(1)}=820\Omega/2pF$ Load=100 $\Omega$				
		$A_{VCL}=+2$		81		MHz
SR	Slew rate	$A_{VCL}=+2$ , 2V step Load=100 $\Omega$	160	230		V/ $\mu s$

**Table 3. Dual supply voltage,  $V_{CC} = \pm 2.5V$ ,  $R_{fb}^{(1)} = 680\Omega$ ,  $T_{amb} = 25^\circ C$  (unless otherwise specified) (continued)**

Symbol	Parameter	Test conditions	Min.	Typ.	Max.	Unit
$T_r$	Rise time	for 200mV step $A_{VCL}=+2$ , $R_{fb}^{(1)}=820\Omega/2pF$ Load=100 $\Omega$		9		ns
$T_f$	Fall time			9		ns
Ov	Overshoot			16		%
St	Settling time @ 0.05%			60		ns
$\Delta G$	Differential gain	$A_{VCL}=+2$ , $R_L=100\Omega$		0.05		%
$\Delta\phi$	Differential phase	$F=4.5MHz$ , $V_{out}=1V_{peak}$		0.05		°
<b>Noise and harmonic performance</b>						
en	Equivalent input voltage noise	Frequency : 1MHz		3		nV/ $\sqrt{Hz}$
in	Equivalent input current noise			8.5		pA/ $\sqrt{Hz}$
THD	Total harmonic distortion	$A_{VCL}=+2$ , $F=2MHz$ $R_L=100\Omega$ $V_{out}=2V_{peak}$		64.4		dB
IM3	Third order inter modulation product	$A_{VCL}=+2$ , $V_{out}=2V_{pp}$ $R_L=100\Omega$ $F1=1MHz$ , $F2=1.1MHz$				dBc
		@900kHz		90		
		@1.2MHz		90		
		@3.1MHz		86		
		@3.2MHz		83		
<b>Matching characteristics</b>						
Gf	Gain flatness	$F=(DC)$ to 6MHz $A_{VCL}=+2$ , $V_{out}=2V_{pp}$		0.1		dB
Vo1/Vo2	Channel separation	$F=1MHz$ to 10MHz		65		dB

1.  $R_{fb}$  is the feedback resistance between the output and the inverting input of the amplifier.

Table 4. Dual supply voltage,  $V_{CC}=\pm 6V$ ,  $R_{fb}^{(1)}=680\Omega$ ,  $T_{amb}=25^{\circ}C$  (unless otherwise specified)

Symbol	Parameter	Test conditions	Min.	Typ.	Max.	Unit
<b>DC performance</b>						
$V_{io}$	Input offset voltage	$T_{amb}$	-1.0	0.9	3.0	mV
		$T_{min} < T_{amb} < T_{max}$		1.3		mV
$\Delta V_{io}$	Input offset voltage drift vs temperature	$T_{min} < T_{amb} < T_{max}$		5		$\mu V/^{\circ}C$
$I_{ib+}$	Non inverting input bias current	$T_{amb}$	-12	1	14	$\mu A$
		$T_{min} < T_{amb} < T_{max}$		1.7		$\mu A$
$I_{ib-}$	Inverting input bias current	$T_{amb}$	-4	3	10	$\mu A$
		$T_{min} < T_{amb} < T_{max}$		3.4		$\mu A$
$R_{OL}$	Transimpedance	$R_L=100\Omega$	600	900		k $\Omega$
$I_{CC}$	Supply current per operator	$T_{amb}$		4	5	mA
		$T_{min} < T_{amb} < T_{max}$		4.1		mA
CMR	Common mode rejection ratio ( $\Delta V_{io}/\Delta V_{io}$ )		58	63		dB
SVR	Supply voltage rejection ratio ( $\Delta V_{CC}/\Delta V_{io}$ )		72	80		dB
PSR	Power supply rejection ratio ( $\Delta V_{CC}/\Delta V_{out}$ )	Gain=1, $R_{load}=3.9k\Omega$		49		dB
<b>Dynamic performance and output characteristics</b>						
$V_{oh}$	High level output voltage	$T_{amb}$ $R_L = 100\Omega$	4.5	4.7		V
		$T_{min} < T_{amb} < T_{max}$ $R_L = 100\Omega$		4.6		V
$V_{ol}$	Low level output voltage	$T_{amb}$ $R_L = 100\Omega$		-4.7	-4.3	V
		$T_{min} < T_{amb} < T_{max}$ $R_L = 100\Omega$		-4.6		V
$ I_{sink} $	Output sink current	$T_{min} < T_{amb} < T_{max}$		47		mA
$I_{source}$	Output source current	$T_{min} < T_{amb} < T_{max}$		46		mA
Bw	-3dB bandwidth	$V_{out}=1V_{pk}$ , $R_{fb}^{(1)}=680\Omega/2pF$ Load=100 $\Omega$				
		$A_{VCL}=+2$		100		MHz
SR	Slew rate	$A_{VCL}=+2$ , 6V step Load=100 $\Omega$	240	450		V/ $\mu s$
$T_r$	Rise time	for 200mV step $A_{VCL}=+2$ , $R_{fb}^{(1)}=680\Omega/2pF$ Load=100 $\Omega$		10.4		ns
$T_f$	Fall time			12.2		ns
Ov	Overshoot			17		%
St	Settling time @ 0.05%			40		ns

**Table 4. Dual supply voltage,  $V_{CC}=\pm 6V$ ,  $R_{fb}^{(1)}= 680\Omega$ ,  $T_{amb} = 25^{\circ}C$  (unless otherwise specified)**

Symbol	Parameter	Test conditions	Min.	Typ.	Max.	Unit
$\Delta G$	Differential gain	$A_{VCL}=+2$ , $R_L=100\Omega$ $F=4.5MHz$ , $V_{out}=2V_{peak}$		0.05		%
$\Delta\phi$	Differential phase			0.05		°
<b>Noise and harmonic performance</b>						
en	Equivalent input voltage noise	Frequency : 1MHz		3		nV/ $\sqrt{Hz}$
in	Equivalent input current noise			8.6		pA/ $\sqrt{Hz}$
THD	Total harmonic distortion	$A_{VCL}=+2$ , $F=2MHz$ $R_L=100\Omega$ $V_{out}=4V_{pp}$		67.7		dB
IM3	Third order inter modulation product	$A_{VCL}=+2$ , $V_{out}=4V_{pp}$ $R_L=100\Omega$ $F1=1MHz$ , $F2=1.1MHz$				dBc
		@900kHz		82		
		@1.2MHz		84		
		@3.1MHz		77		
		@3.2MHz		73		
<b>Matching characteristics</b>						
Gf	Gain flatness	$F=(DC)$ to 6MHz $A_{VCL}=+2$ , $V_{out}=4V_{pp}$		0.1		dB
Vo1/Vo2	Channel separation	$F=1MHz$ to 10MHz		65		dB

1.  $R_{fb}$  is the feedback resistance between the output and the inverting input of the amplifier.

### 3 Standby mode

**Table 5.**  $T_{amb} = 25^{\circ}\text{C}$  (unless otherwise specified),  $V_{CC} = \pm 6\text{V}$

Symbol	Parameter	Test conditions	Min.	Typ.	Max.	Unit
$V_{low}$	Standby low level		$V_{CC}^{-}$		$(V_{CC}^{-} + 0.8)$	V
$V_{high}$	Standby high level		$(V_{CC}^{-} + 2)$		$(V_{CC}^{+})$	V
$I_{CC-STBY}$	Current consumption per operator in Standby mode			26	40	$\mu\text{A}$
$I_{sol}$	Input/output isolation	$F=1\text{MHz}$		-90		dB
$Z_{out}$	Output impedance ( $R_{out} // C_{out}$ )	$R_{out}$ $C_{out}$		31 25		$\text{M}\Omega$ $\text{pF}$
$T_{on}$	Time from Standby mode to active mode			2		$\mu\text{s}$
$T_{off}$	Time from active mode to Standby mode	Down to $I_{CC-STBY}=40\mu\text{A}$		13		$\mu\text{s}$

**Table 6.** TSH111 standby control pin status

TSH111 standby control pin 8 ( $\overline{\text{SBY}}$ )	Operator status
$V_{low}$	Standby
$V_{high}$	Active

**Table 7.** TSH113 standby control pin status

TSH113 standby control			Operator status		
pin 1 ( $\overline{\text{SBY}} \text{ OP1}$ )	pin 2 ( $\overline{\text{SBY}} \text{ OP2}$ )	pin 3 ( $\overline{\text{SBY}} \text{ OP}$ )	OP1	OP1	OP3
$V_{low}$	x	x	Standby	x	x
$V_{high}$	x	x	Active	x	x
x	$V_{low}$	x	x	Standby	x
x	$V_{high}$		x	Active	x
x	x	$V_{low}$	x	x	Standby
x	x	$V_{high}$	x	x	Active

## 4 Package information

In order to meet environmental requirements, STMicroelectronics offers these devices in ECOPACK<sup>®</sup> packages. These packages have a lead-free second level interconnect. The category of second level interconnect is marked on the package and on the inner box label, in compliance with JEDEC Standard JESD97. The maximum ratings related to soldering conditions are also marked on the inner box label. ECOPACK is an STMicroelectronics trademark. ECOPACK specifications are available at: [www.st.com](http://www.st.com).



## 4.1 SO-8 package mechanical data

Figure 1. SO-8 package mechanical data

Ref.	Dimensions					
	Millimeters			Inches		
	Min.	Typ.	Max.	Min.	Typ.	Max.
A			1.75			0.069
A1	0.10		0.25	0.004		0.010
A2	1.25			0.049		
b	0.28		0.48	0.011		0.019
c	0.17		0.23	0.007		0.010
D	4.80	4.90	5.00	0.189	0.193	0.197
H	5.80	6.00	6.20	0.228	0.236	0.244
E1	3.80	3.90	4.00	0.150	0.154	0.157
e		1.27			0.050	
h	0.25		0.50	0.010		0.020
L	0.40		1.27	0.016		0.050
k	1°		8°	1°		8°
ccc			0.10			0.004

## 4.2 TSSOP8 package mechanical data

Figure 2. TSSOP8 package mechanical data

Ref.	Dimensions					
	Millimeters			Inches		
	Min.	Typ.	Max.	Min.	Typ.	Max.
A			1.2			0.047
A1	0.05		0.15	0.002		0.006
A2	0.80	1.00	1.05	0.031	0.039	0.041
b	0.19		0.30	0.007		0.012
c	0.09		0.20	0.004		0.008
D	2.90	3.00	3.10	0.114	0.118	0.122
E	6.20	6.40	6.60	0.244	0.252	0.260
E1	4.30	4.40	4.50	0.169	0.173	0.177
e		0.65			0.0256	
k	0°		8°	0°		8°
L	0.45	0.60	0.75	0.018	0.024	0.030
L1		1			0.039	
aaa		0.1			0.004	

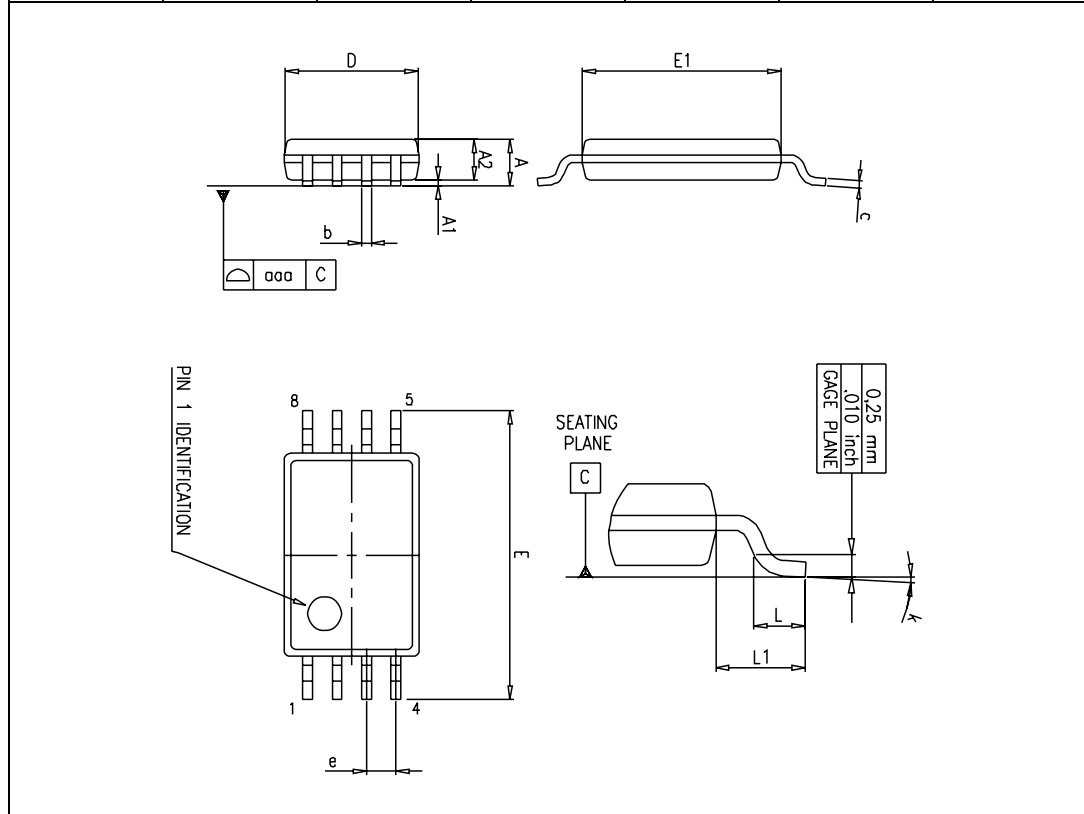

### 4.3 SO-14 package mechanical data

Figure 3. SO-14 package mechanical data

Ref.	Dimensions					
	Millimeters			Inches		
	Min.	Typ.	Max.	Min.	Typ.	Max.
A			1.75			0.068
a1	0.1		0.2	0.003		0.007
a2			1.65			0.064
b	0.35		0.46	0.013		0.018
b1	0.19		0.25	0.007		0.010
C		0.5			0.019	
c1	45° (typ.)					
D	8.55		8.75	0.336		0.344
E	5.8		6.2	0.228		0.244
e		1.27			0.050	
e3		7.62			0.300	
F	3.8		4.0	0.149		0.157
G	4.6		5.3	0.181		0.208
L	0.5		1.27	0.019		0.050
M			0.68			0.026
S	8° (max.)					

### 4.4 TSSOP14 package mechanical data

Figure 4. TSSOP14 package mechanical data

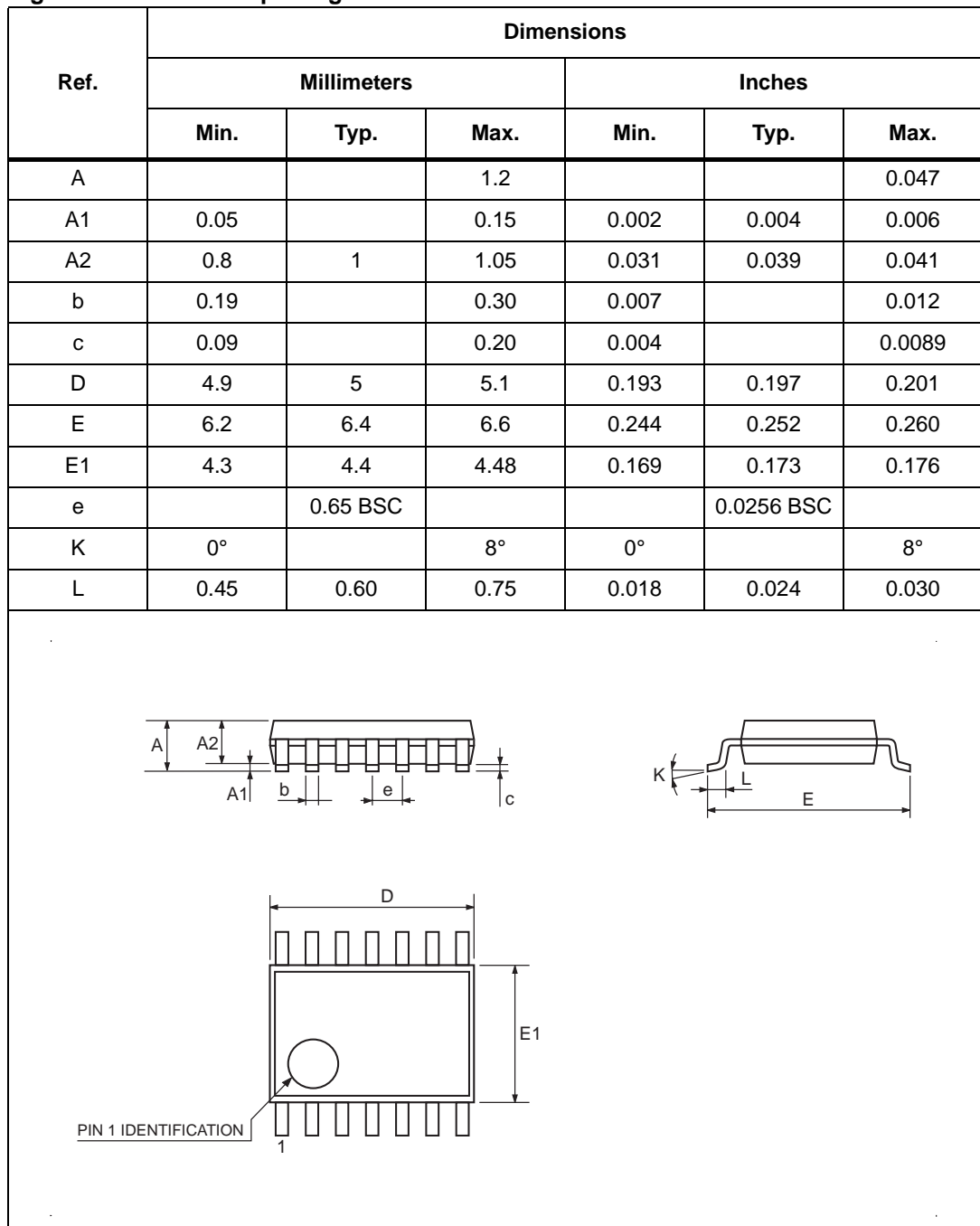

## 4.5 SOT23-5 package mechanical data

Figure 5. SOT23-5 package (Inches)

Ref.	Dimensions					
	Millimeters			Inches		
	Min.	Typ.	Max.	Min.	Typ.	Max.
A	0.90		1.45	0.035		0.057
A1	0.00		0.15	0.00		0.006
A2	0.90		1.30	0.035		0.051
b	0.35		0.50	0.014		0.02
C	0.09		0.20	0.003		0.008
D	2.80		3.00	0.110		0.118
H	2.60		3.00	0.102		0.118
E	1.50		1.75	0.059		0.069
e		0.95			0.037	
e1		1.9			0.075	
L	0.35		0.55	0.014		0.022

## 5 Ordering information

**Table 8. Order codes**

Part number	Temperature range	Package	Packing	Marking
TSH110ILT	-40°C to +85°C	SOT23-5	Tape & reel	K302
TSH110IYLT <sup>(1)</sup>		SOT23-5 (Automotive grade level)	Tape & reel	K309
TSH111ID TSH111IDT		SO-8	Tube or Tape & reel	H111I
TSH111IPT		TSSOP8 (Thin shrink outline package)	Tape & reel	H111I
TSH112ID TSH112IDT		SO-8	Tube or Tape & reel	H112I
TSH112IPT		TSSOP8 (Thin shrink outline package)	Tape & reel	H112I
TSH113ID TSH113IDT		SO-14	Tube or Tape & reel	TSH113I
TSH113IPT		TSSOP14	Tape & reel	TSH113I
TSH114ID TSH114IDT		SO-14	Tube or Tape & reel	TSH114I
TSH114IPT		TSSOP14	Tape & reel	TSH114I

1. Qualification and characterization according to AEC Q100 and Q003 or equivalent, advanced screening according to AEC Q001 & Q 002 or equivalent are on-going.

## 6 Revision history

**Table 9. Document revision history**

Date	Revision	Changes
4-Oct-2001	1	Initial release.
22-Oct-2007	2	Added TSH110ILT/TSH110IYLT order codes to <a href="#">Table 8: Order codes</a> . Document reformatted.

**Please Read Carefully:**

Information in this document is provided solely in connection with ST products. STMicroelectronics NV and its subsidiaries ("ST") reserve the right to make changes, corrections, modifications or improvements, to this document, and the products and services described herein at any time, without notice.

All ST products are sold pursuant to ST's terms and conditions of sale.

Purchasers are solely responsible for the choice, selection and use of the ST products and services described herein, and ST assumes no liability whatsoever relating to the choice, selection or use of the ST products and services described herein.

No license, express or implied, by estoppel or otherwise, to any intellectual property rights is granted under this document. If any part of this document refers to any third party products or services it shall not be deemed a license grant by ST for the use of such third party products or services, or any intellectual property contained therein or considered as a warranty covering the use in any manner whatsoever of such third party products or services or any intellectual property contained therein.

**UNLESS OTHERWISE SET FORTH IN ST'S TERMS AND CONDITIONS OF SALE ST DISCLAIMS ANY EXPRESS OR IMPLIED WARRANTY WITH RESPECT TO THE USE AND/OR SALE OF ST PRODUCTS INCLUDING WITHOUT LIMITATION IMPLIED WARRANTIES OF MERCHANTABILITY, FITNESS FOR A PARTICULAR PURPOSE (AND THEIR EQUIVALENTS UNDER THE LAWS OF ANY JURISDICTION), OR INFRINGEMENT OF ANY PATENT, COPYRIGHT OR OTHER INTELLECTUAL PROPERTY RIGHT.**

**UNLESS EXPRESSLY APPROVED IN WRITING BY AN AUTHORIZED ST REPRESENTATIVE, ST PRODUCTS ARE NOT RECOMMENDED, AUTHORIZED OR WARRANTED FOR USE IN MILITARY, AIR CRAFT, SPACE, LIFE SAVING, OR LIFE SUSTAINING APPLICATIONS, NOR IN PRODUCTS OR SYSTEMS WHERE FAILURE OR MALFUNCTION MAY RESULT IN PERSONAL INJURY, DEATH, OR SEVERE PROPERTY OR ENVIRONMENTAL DAMAGE. ST PRODUCTS WHICH ARE NOT SPECIFIED AS "AUTOMOTIVE GRADE" MAY ONLY BE USED IN AUTOMOTIVE APPLICATIONS AT USER'S OWN RISK.**

Resale of ST products with provisions different from the statements and/or technical features set forth in this document shall immediately void any warranty granted by ST for the ST product or service described herein and shall not create or extend in any manner whatsoever, any liability of ST.

ST and the ST logo are trademarks or registered trademarks of ST in various countries.

Information in this document supersedes and replaces all information previously supplied.

The ST logo is a registered trademark of STMicroelectronics. All other names are the property of their respective owners.

© 2007 STMicroelectronics - All rights reserved

STMicroelectronics group of companies

Australia - Belgium - Brazil - Canada - China - Czech Republic - Finland - France - Germany - Hong Kong - India - Israel - Italy - Japan - Malaysia - Malta - Morocco - Singapore - Spain - Sweden - Switzerland - United Kingdom - United States of America

[www.st.com](http://www.st.com)



## X-ON Electronics

Largest Supplier of Electrical and Electronic Components

*Click to view similar products for [Operational Amplifiers - Op Amps](#) category:*

*Click to view products by [STMicroelectronics](#) manufacturer:*

Other Similar products are found below :

[OPA2991IDSGR](#) [OPA607IDCKT](#) [007614D](#) [633773R](#) [635798C](#) [635801A](#) [702115D](#) [709228FB](#) [741528D](#) [NCV33072ADR2G](#)  
[SC2903VDR2G](#) [LM258AYDT](#) [LM358SNG](#) [430227FB](#) [430228DB](#) [460932C](#) [AZV831KTR-G1](#) [409256CB](#) [430232AB](#) [LM2904DR2GH](#)  
[LM358YDT](#) [LT1678IS8](#) [042225DB](#) [058184EB](#) [070530X](#) [714228XB](#) [714846BB](#) [873836HB](#) [MIC918YC5-TR](#) [TS912BIYDT](#)  
[NCS2004MUTAG](#) [NCV33202DMR2G](#) [M38510/13101BPA](#) [NTE925](#) [SC2904DR2G](#) [SC358DR2G](#) [LM358EDR2G](#) [AP4310AUMTR-AG1](#)  
[HA1630D02MMEL-E](#) [NJM358CG-TE2](#) [HA1630S01LPEL-E](#) [LM324AWPT](#) [HA1630Q06TELL-E](#) [NJM4558CG-TE2](#) [AZV358MMTR-G1](#)  
[SCY33178DR2G](#) [NCS4325DR2G](#) [LM7301SN1T1G](#) [NJU77806F3-TE1](#) [NCV833DR2G](#)