



TSH345

Triple video buffer with selectable filter for HD and SD video applications

Features

- Selectable 6th order filtering of 36 MHz, 18 MHz and 9 MHz
- 5 V single-supply operation
- Internal input DC level shifter
- No input capacitor required
- 3 matched 6 dB amplifiers
- AC or DC output-coupled
- Very low harmonic distortion
- Specified for 150 Ω loads
- Data min. and max. are tested during production

Applications

- High-end video systems
- High definition TV (HDTV)
- Broadcast and graphic video
- Multimedia products

Description

The TSH345 is a triple single-supply video buffer featuring an internal gain of 6 dB and selectable filtering for HD and SD video outputs on 75 Ω video lines. The TSH345 is ideal to drive YC, CVBS, YUV, YPbPr or RGB signals from video DAC outputs.

The main advantage of this circuit is its input DC level shifter. It allows driving video signals on 75 Ω video lines without damaging the synchronization tip and without input or output capacitors when using a single 5 V power supply. The DC level shifter is internally fixed and optimized to keep the output video signals between low and high output rails in the best position for the greatest linearity.

The TSH345 is available in SO-14 and TSSOP-14 plastic packages for optimum space saving.

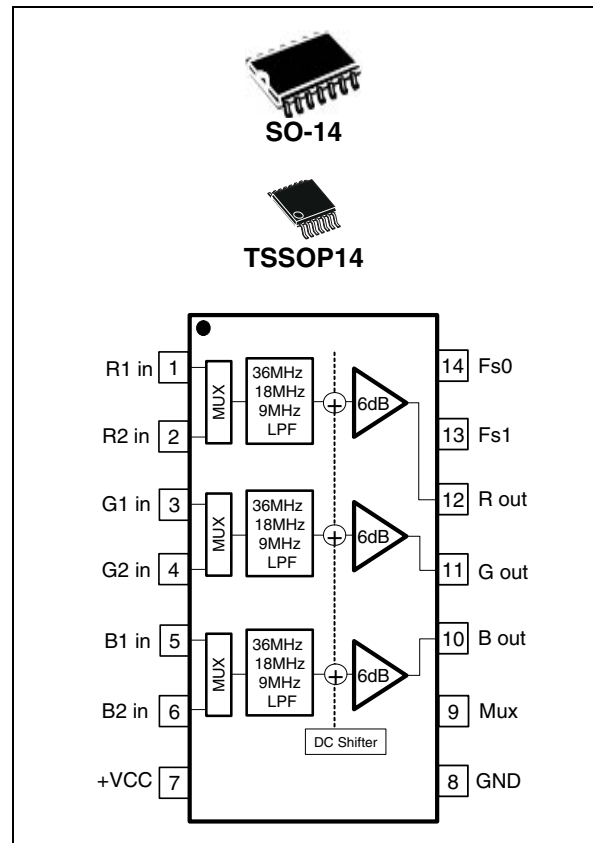

1 Absolute maximum ratings and operating conditions

Table 1. Absolute maximum ratings

Symbol	Parameter	Value	Unit
V_{CC}	Supply voltage ⁽¹⁾	6	V
V_{in}	Input voltage range	2.5	V
T_{oper}	Operating free air temperature range	-40 to +85	°C
T_{stg}	Storage temperature	-65 to +150	°C
T_j	Maximum junction temperature	150	°C
R_{thjc}	Thermal resistance junction to case		
	SO-14 TSSOP14	22 32	°C/W
R_{thja}	Thermal resistance junction to ambient area		
	SO-14 TSSOP14	125 110	°C/W
P_{max}	Maximum power dissipation (at $T_{amb} = 25^\circ\text{C}$) for $T_j = 150^\circ\text{C}$		
	SO-14 TSSOP14	1 1.1	W
ESD	CDM: charged device model	250	V
	HBM: human body model	2	kV
	MM: machine model	100	V

1. All voltage values, except differential voltage, are with respect to network terminal.

Table 2. Operating conditions

Symbol	Parameter	Value	Unit
V_{CC}	Power supply voltage	4.5 to 5.5 ⁽¹⁾	V

1. Tested in full production with +5 V single power supply.

2 Electrical characteristics

Table 3. Electrical characteristics at $V_{CC} = +5\text{ V}$ single supply, $T_{amb} = 25^\circ\text{C}$ (unless otherwise specified)

Symbol	Test conditions	Min.	Typ.	Max.	Unit
DC performance					
V_{DC}	Output DC shift $R_L = 150\ \Omega$, T_{amb} $-40^\circ\text{C} < T_{amb} < +85^\circ\text{C}$	100	240 310	440	mV
I_{ib}	Input bias current T_{amb} , input to GND $-40^\circ\text{C} < T_{amb} < +85^\circ\text{C}$		1.3 1.4	3.6	μA
R_{in}	Input resistance, T_{amb}		1		$\text{M}\Omega$
C_{in}	Input capacitance, T_{amb}		0.1		pF
I_{CC}	Total supply current (3 x operators) No load, input to GND $-40^\circ\text{C} < T_{amb} < +85^\circ\text{C}$		44.6 45	51.6	mA
G	DC voltage gain $R_L = 150\ \Omega$, $V_{in} = 1.4\text{V}$ $-40^\circ\text{C} < T_{amb} < +85^\circ\text{C}$	1.96	2 1.96	2.05	V/V
Output characteristics					
V_{OH}	High level output voltage $R_L = 150\ \Omega$ $-40^\circ\text{C} < T_{amb} < +85^\circ\text{C}$	3.4	3.9 3.8		V
V_{OL}	Low level output voltage $R_L = 150\ \Omega$		47		mV
I_{out}	I_{source} T_{amb} $-40^\circ\text{C} < T_{amb} < +85^\circ\text{C}$	76	100 91		mA
	I_{sink} $-40^\circ\text{C} < T_{amb} < +85^\circ\text{C}$	106	134 126		mA
Filtering					
Standard definition	Bandwidth F1 selected, small signal, $V_{ICM} = 0.5\text{ V}$, $R_L = 150\ \Omega$ -3 dB bandwidth -1 dB bandwidth				MHz
	Attenuation F1 selected/F=27 MHz, small signal, $V_{ICM} = 0.5\text{ V}$, $R_L = 150\ \Omega$	5	9 5.7		dB

Table 3. Electrical characteristics at $V_{CC} = +5\text{ V}$ single supply, $T_{amb} = 25^\circ\text{C}$ (unless otherwise specified) (continued)

Symbol	Test conditions	Min.	Typ.	Max.	Unit
Standard definition with progressive scanning	Bandwidth F2 selected, small signal, $V_{ICM} = 0.5\text{ V}$, $R_L = 150\ \Omega$ -3 dB bandwidth -1 dB bandwidth	13	21 18		MHz
	Attenuation F2 selected/ $F = 54\text{ MHz}$, small signal, $V_{ICM} = 0.5\text{ V}$, $R_L = 150\ \Omega$	32	38		dB
High definition	Bandwidth F3 selected, small signal, $V_{ICM} = 0.5\text{ V}$, $R_L = 150\ \Omega$ -3 dB bandwidth -1 dB bandwidth	25	36 32		MHz
	Attenuation F3 selected/ $F = 74.25\text{ MHz}$, small signal, $V_{ICM} = 0.5\text{ V}$, $R_L = 150\ \Omega$	25	32		dB
D	Delay between each channel		0.5		ns
gd	Group delay variation F1 selected/ $F = 0$ to 6 MHz		11		ns
Δg	Differential gain F1 selected/ $F = 6\text{ MHz}$, $R_L = 150\ \Omega$		0.38		%
$\Delta\Phi$	Differential phase F1 selected/ $F = 6\text{ MHz}$, $R_L = 150\ \Omega$		0.5		°
Noise					
eN	Total input voltage noise in Standard Definition $F = 100\text{ kHz}$, $R_{IN} = 50\ \Omega$		74		nV/ $\sqrt{\text{Hz}}$
	Total input voltage noise in High Definition $F = 100\text{ kHz}$, $R_{IN} = 50\ \Omega$		86		
Standby mode					
I_{STBY}	Total current consumption in standby mode $Fs1 = 1$, $Fs0 = 1$ T_{amb} $-40^\circ\text{ C} < T_{amb} < +85^\circ\text{ C}$		440 480	690	μA
T_{on}	Time from standby to active mode		5		μs
T_{off}	Time from active to standby mode		5		μs
Fs1, Fs0 and Mux features					
V_{high}	High level	0.9			V
V_{low}	Low level			0.3	V

Table 4. Filter and standby settings, $V_{CC} = +5\text{ V}$ single supply, $T_{amb} = 25^\circ\text{C}$

Fs1⁽¹⁾	Fs0⁽¹⁾	Settings	
0	0	F3	Filtering for high definition (HD)
0	1	F2	Filtering for progressive video (PV)
1	0	F3	Filtering for standard definition (SD)
1	1	Standby	TSH345 in standby mode

1. Fs1 and Fs0 pins must never be left floating.

Table 5. Mux settings, $V_{CC} = +5\text{ V}$ single supply, $T_{amb} = 25^\circ\text{C}$

Mux⁽¹⁾	Settings	
0	R1 G1 B1	Video1 selected
1	R2 G2 B2	Video2 selected

1. The MUX pin must never be left floating.

Figure 1. Filtering

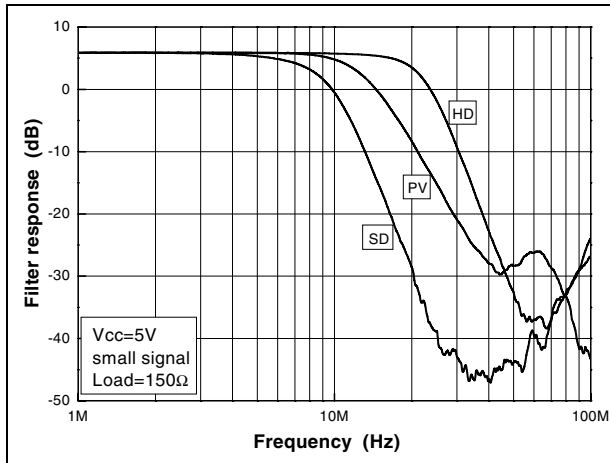

Figure 2. Gain flatness

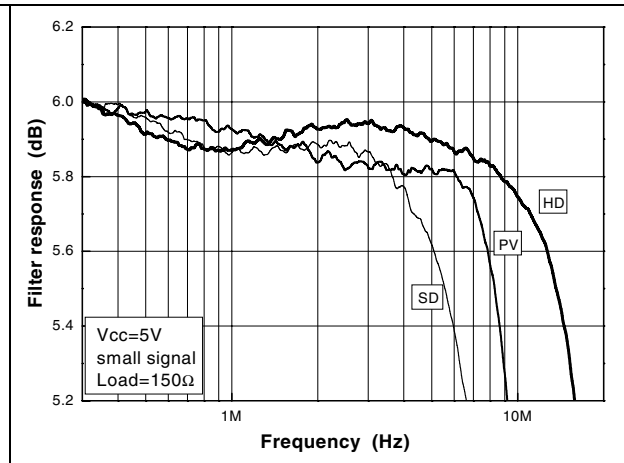

Figure 3. Distortion 1 MHz (HD)

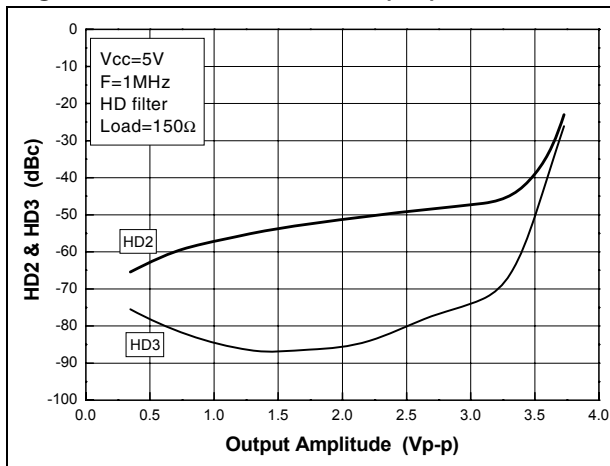

Figure 4. Distortion 10 MHz (HD)

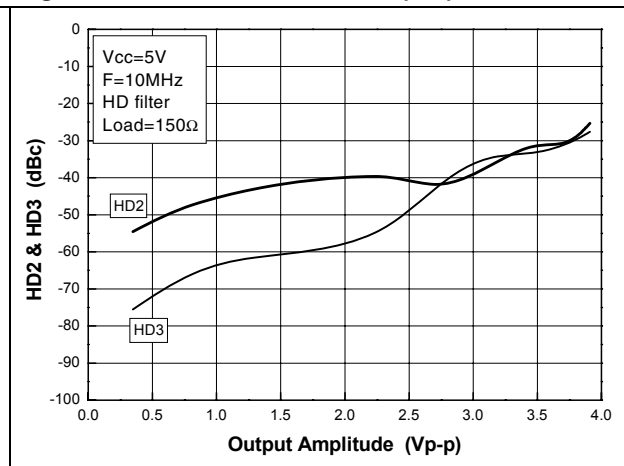

Figure 5. Distortion 1 MHz (PV)

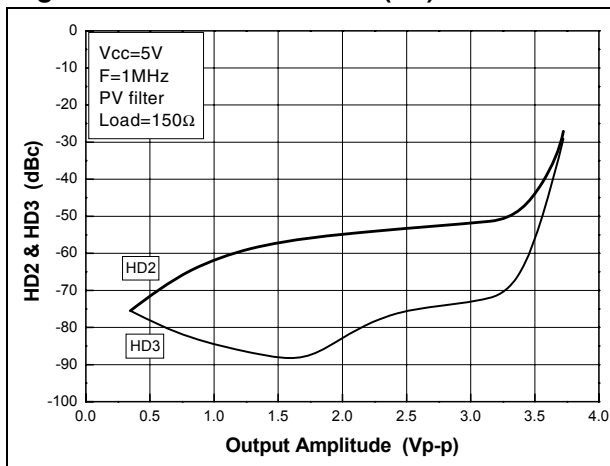

Figure 6. Distortion 10 MHz (PV)

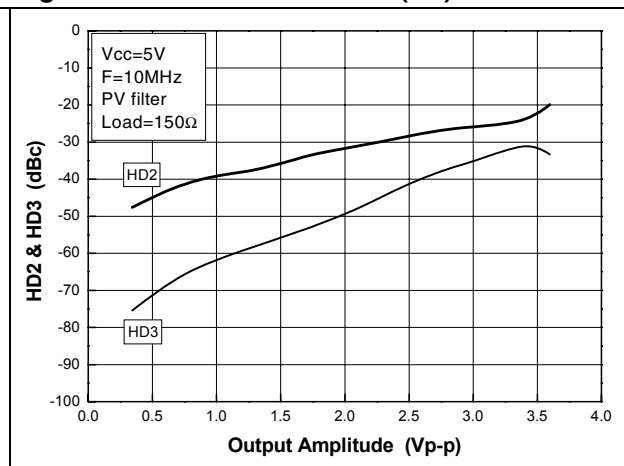

Figure 7. Distortion 1 MHz (SD filter)

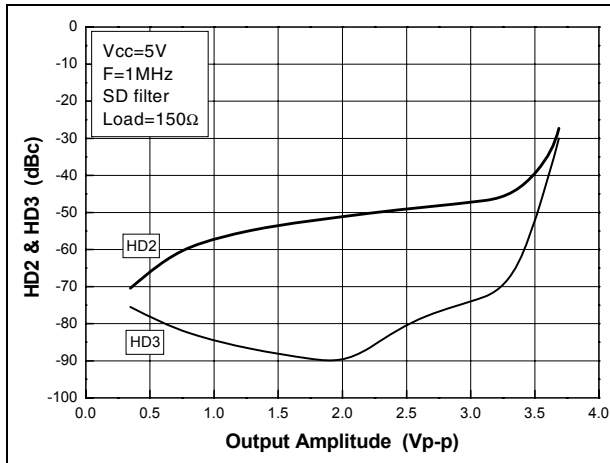

Figure 8. Input noise vs. frequency

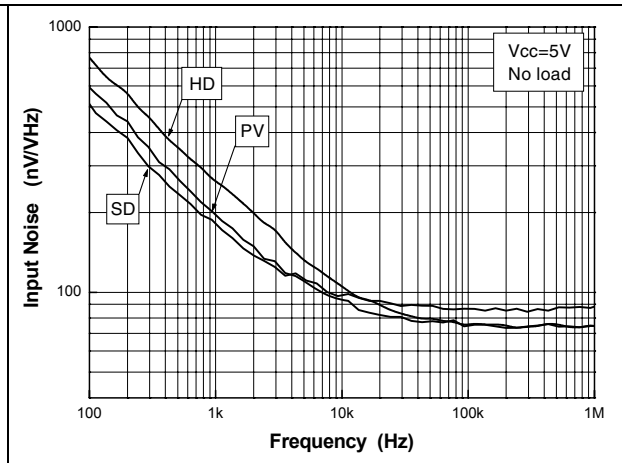

Figure 9. Gain vs. input amplitude

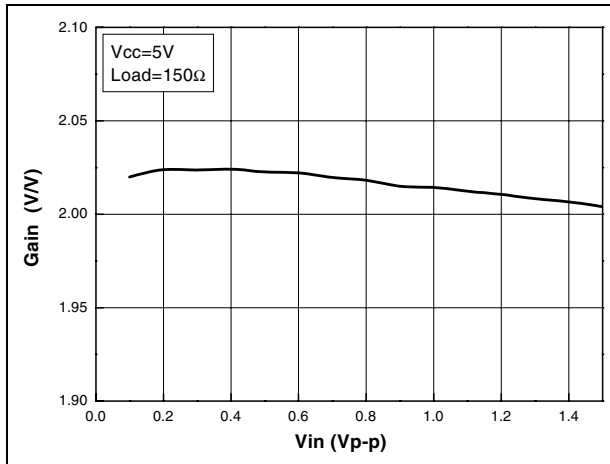

Figure 10. Channel crosstalk vs. frequency

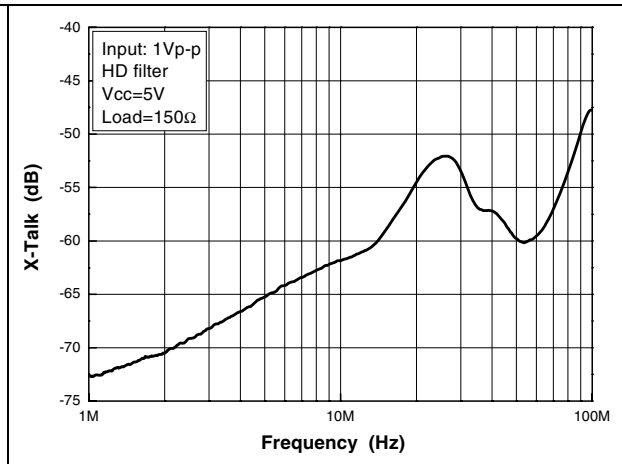

Figure 11. Output vs input amplitude

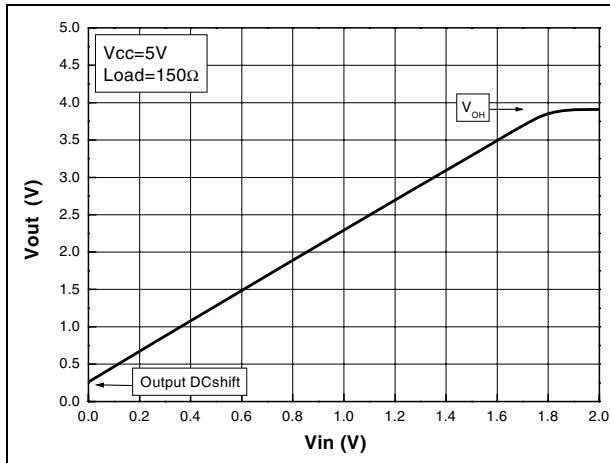

Figure 12. MUX isolation

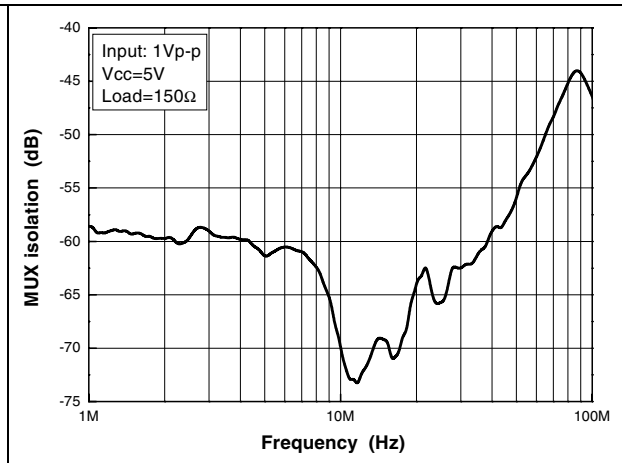

Figure 13. Current consumption vs. supply

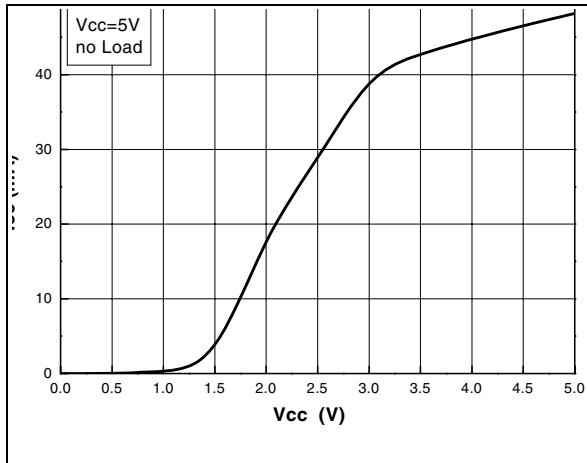

Figure 14. Supply current vs. temperature

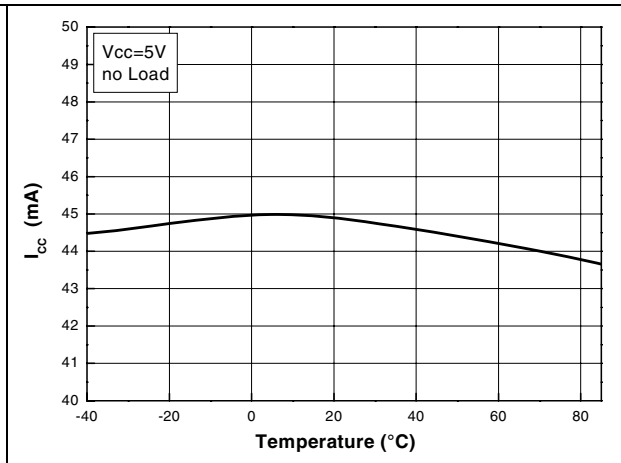

Figure 15. Filtering vs. temperature

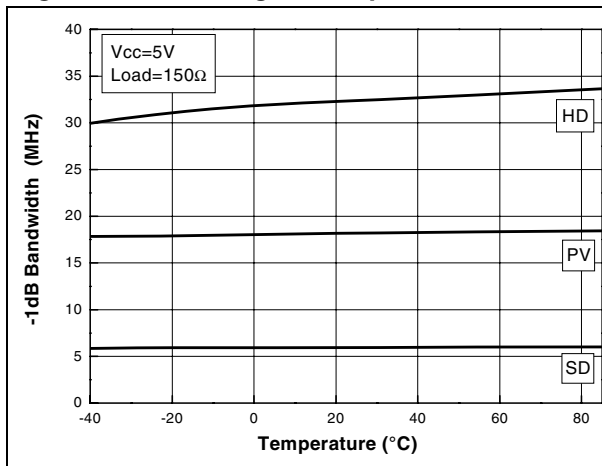

Figure 16. Filter attenuation vs. temperature

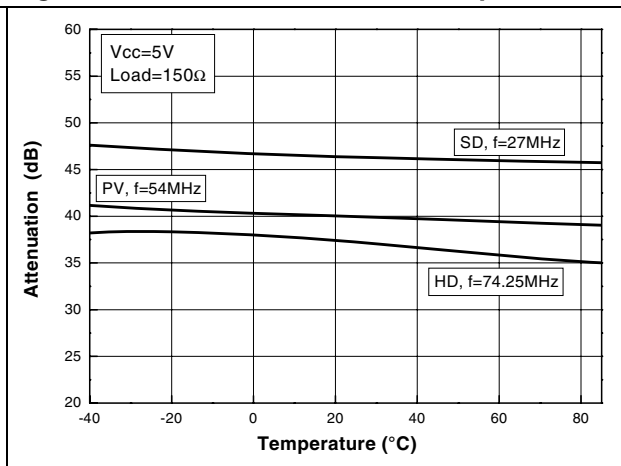

Figure 17. Gain matching vs. temperature

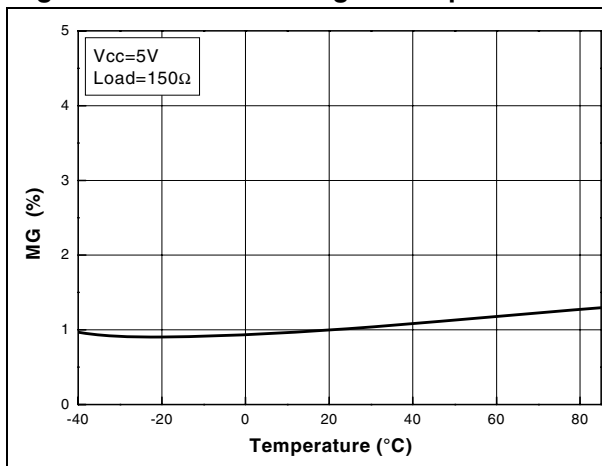

Figure 18. Output DC shift vs. temperature

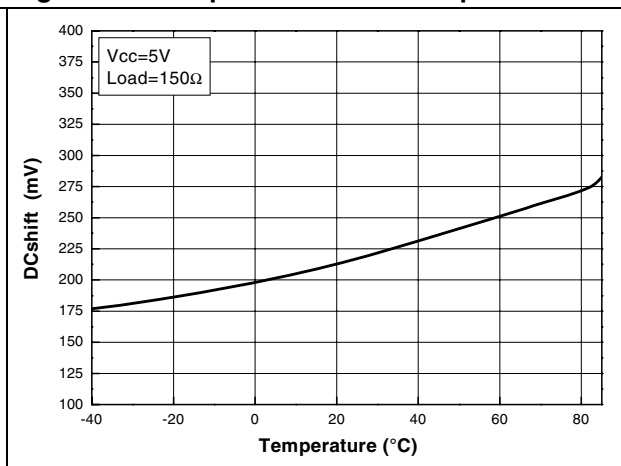

Figure 19. Standby current vs. temperature

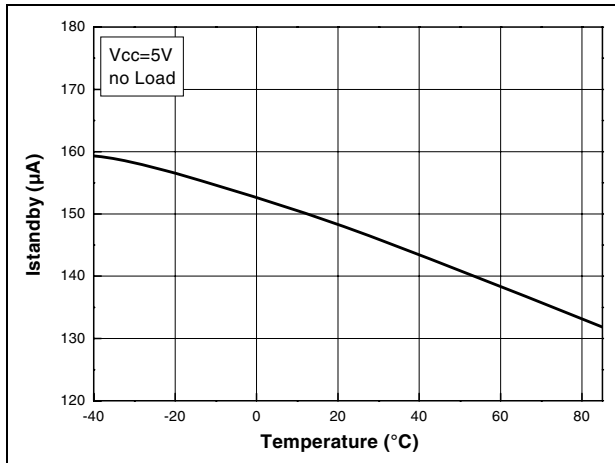

Figure 20. Isink vs. temperature

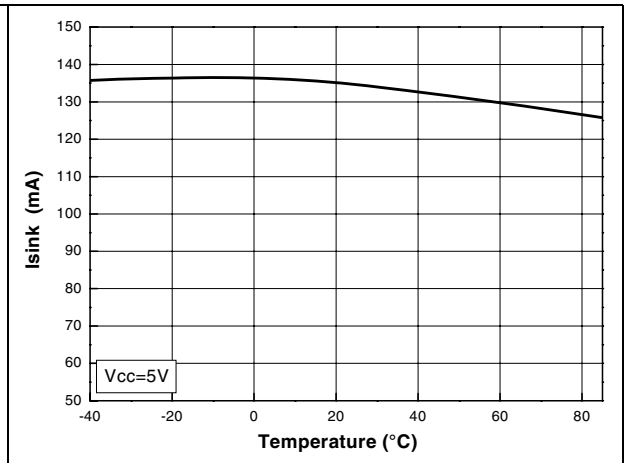

Figure 21. Isource vs. temperature

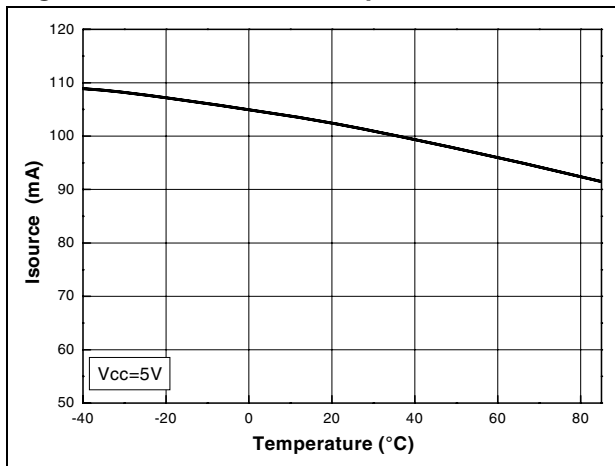

Figure 22. Ibias vs. temperature

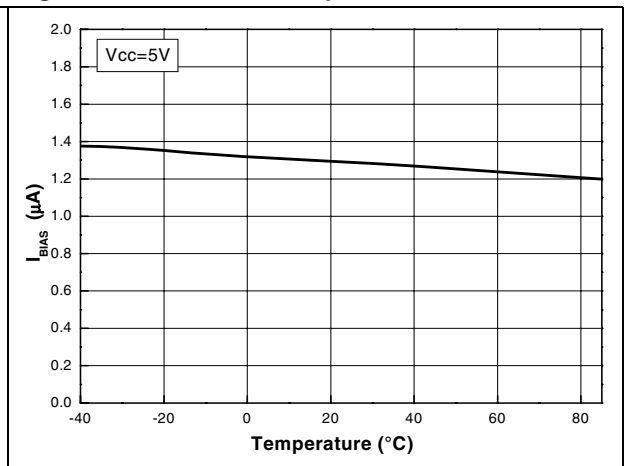

Figure 23. VOL vs. temperature

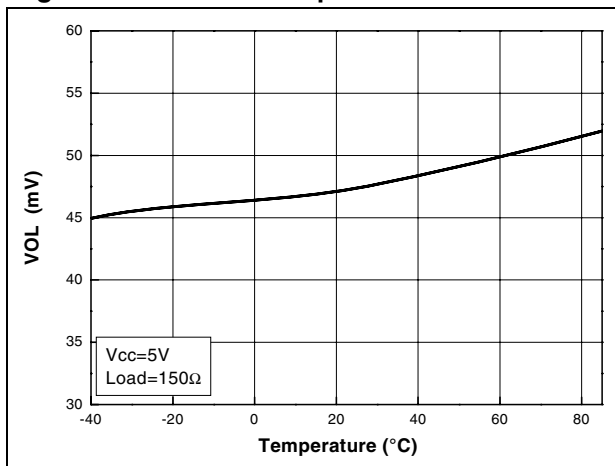

Figure 24. VOH vs. temperature

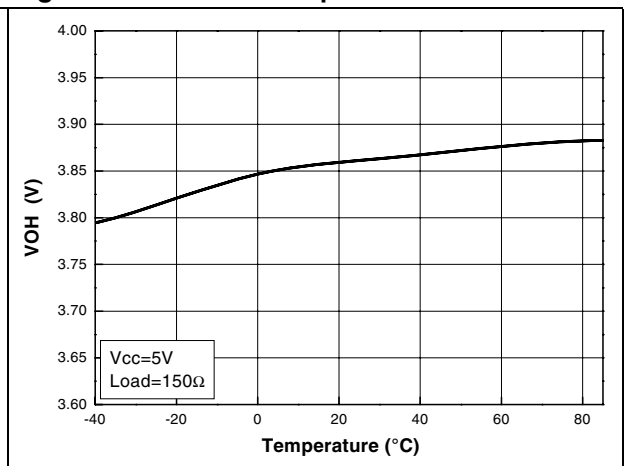
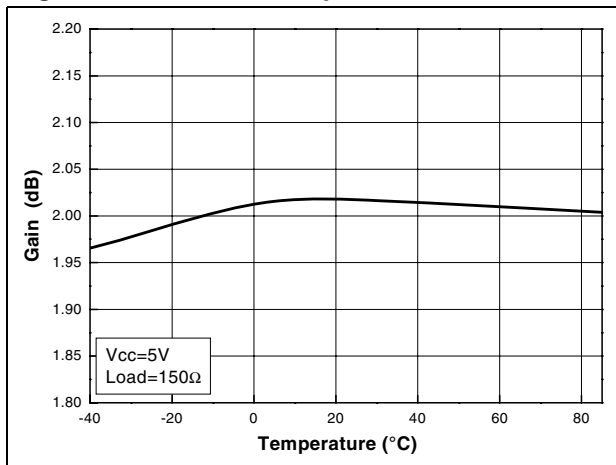

Figure 25. Gain vs. temperature



2.1 Power supply considerations: improving the power supply noise rejection

Correct power supply bypassing is very important to optimize performance in low- and high-frequency ranges. Bypass capacitors should be placed as close as possible to the IC pin (pin 4) to improve high-frequency bypassing. A capacitor (C_{LF}) greater than $10\ \mu\text{F}$ is necessary to improve the PSRR in low frequencies. For better quality bypassing, you can add a capacitor of $100\ \text{nF}$ (C_{HF}). C_{HF} must be placed as close as possible to the IC pin to improve the noise supply rejection in the higher frequencies. A coil can be added in order to better reject the noise from the supply and to prevent current peaks as much as possible.

Figure 26. Circuit for power supply bypassing

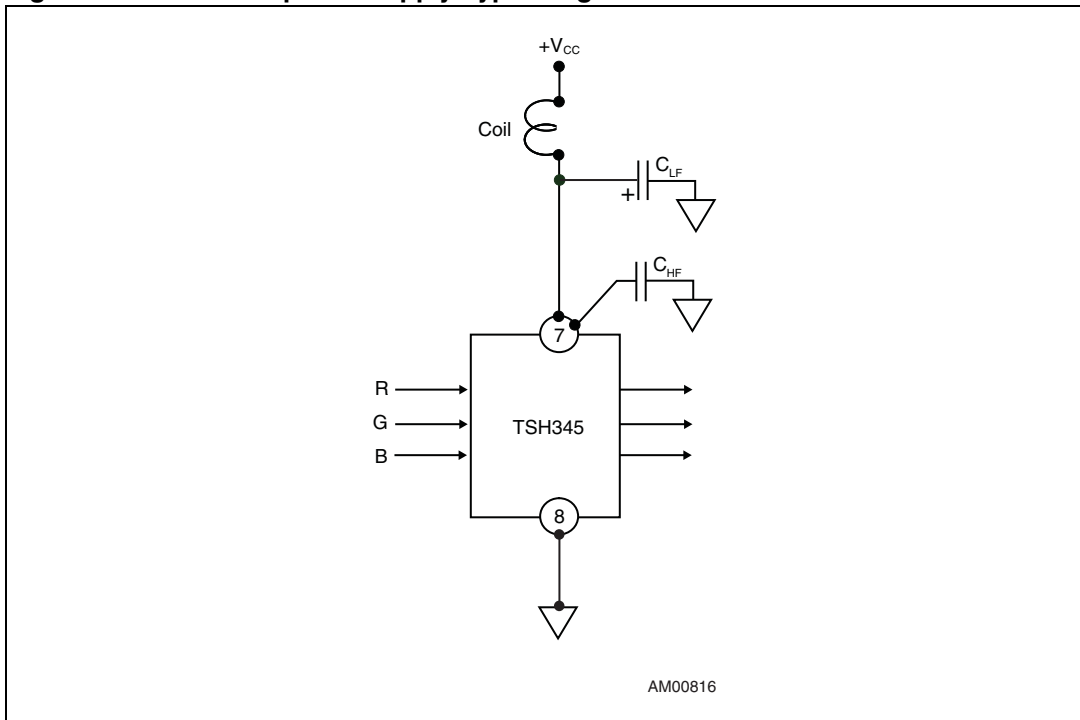

Figure 27. Circuit for noise rejection improvement measurement

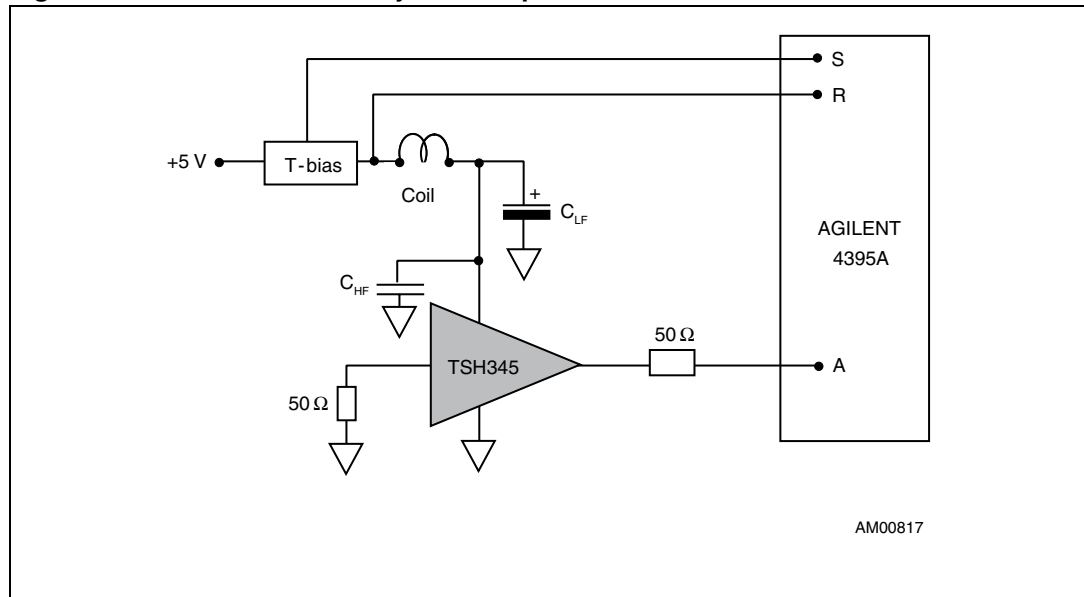
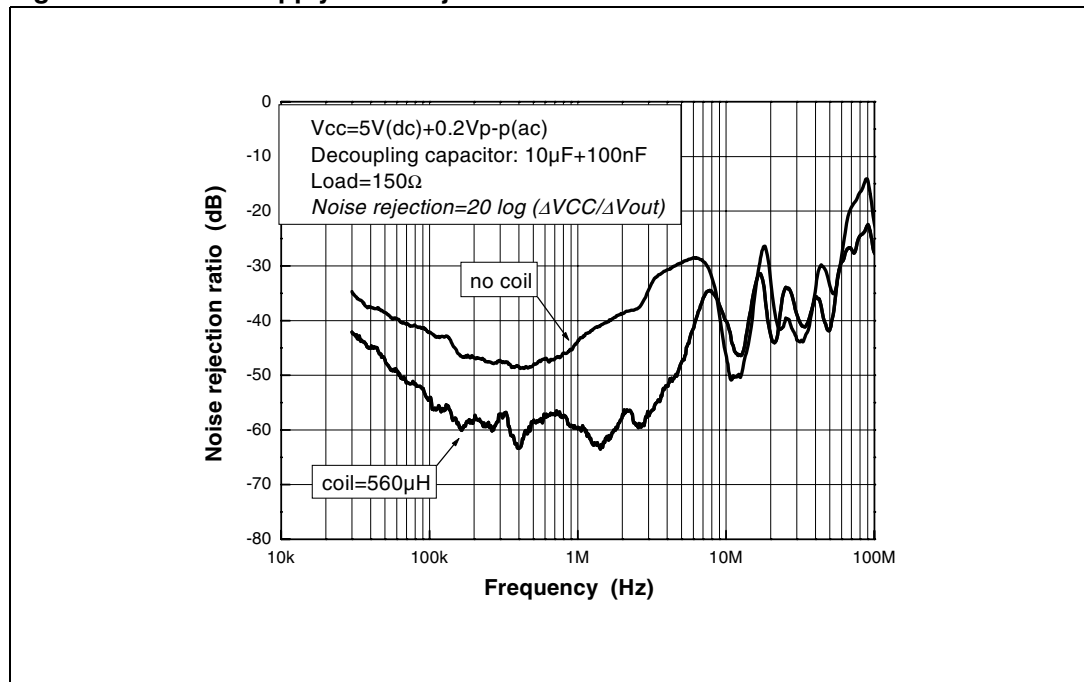

Figure 28 shows how the power supply noise rejection evolves according to the frequency and depending on how carefully power supply decoupling is achieved.

Figure 28. Power supply noise rejection



3 Using the TSH345 to drive YC, CVBS, YUV, YPbPr and RGB video components

Figure 29. Implementation of the video driver on output video DACs

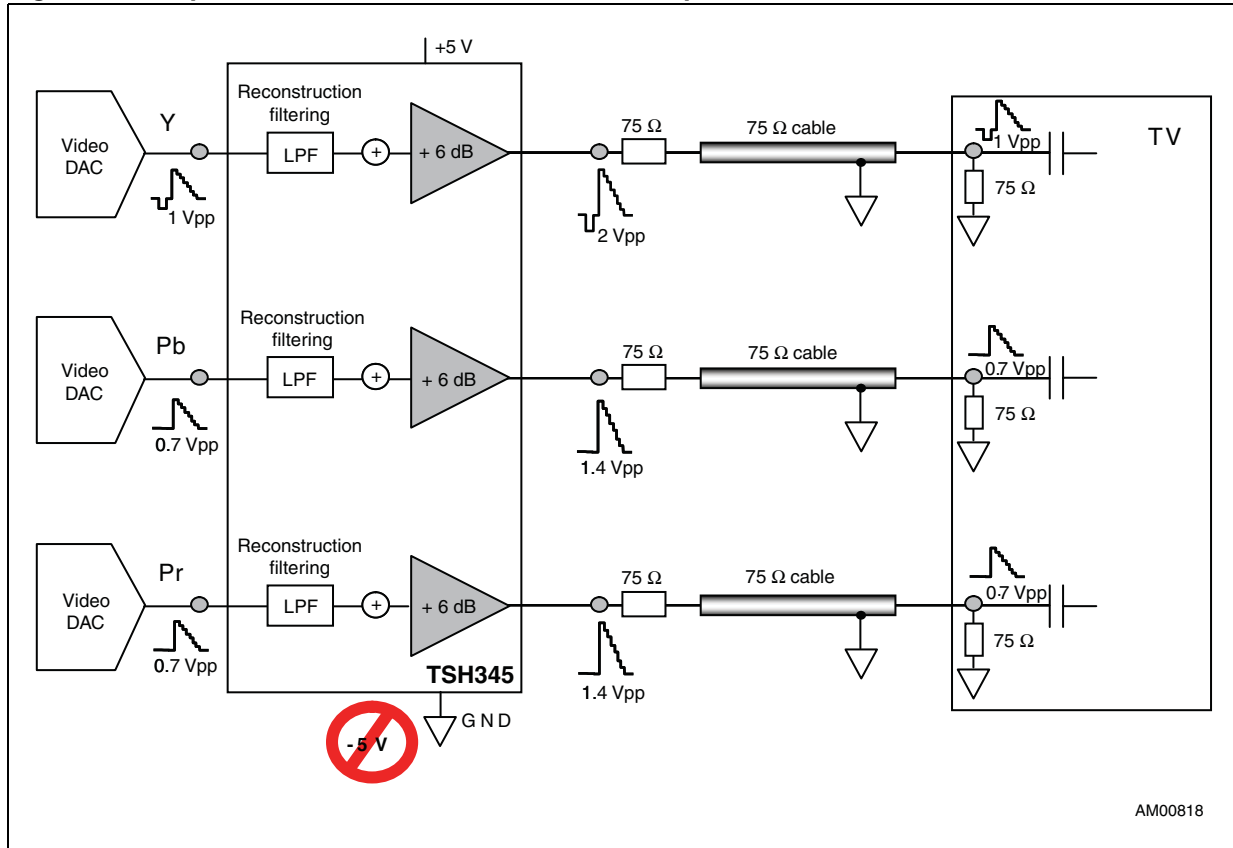

Figure 30. Synchronization details (example for a black picture)

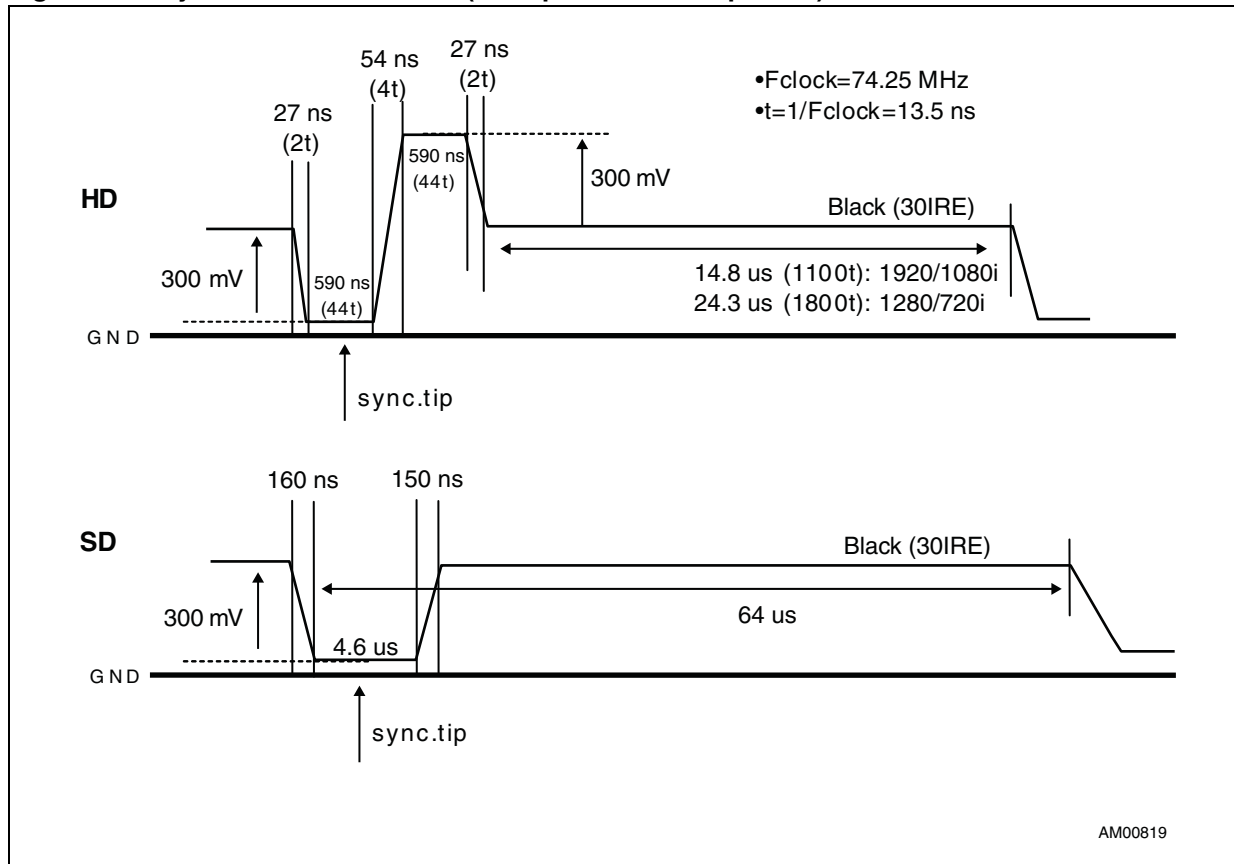

Figure 31. HD video signal

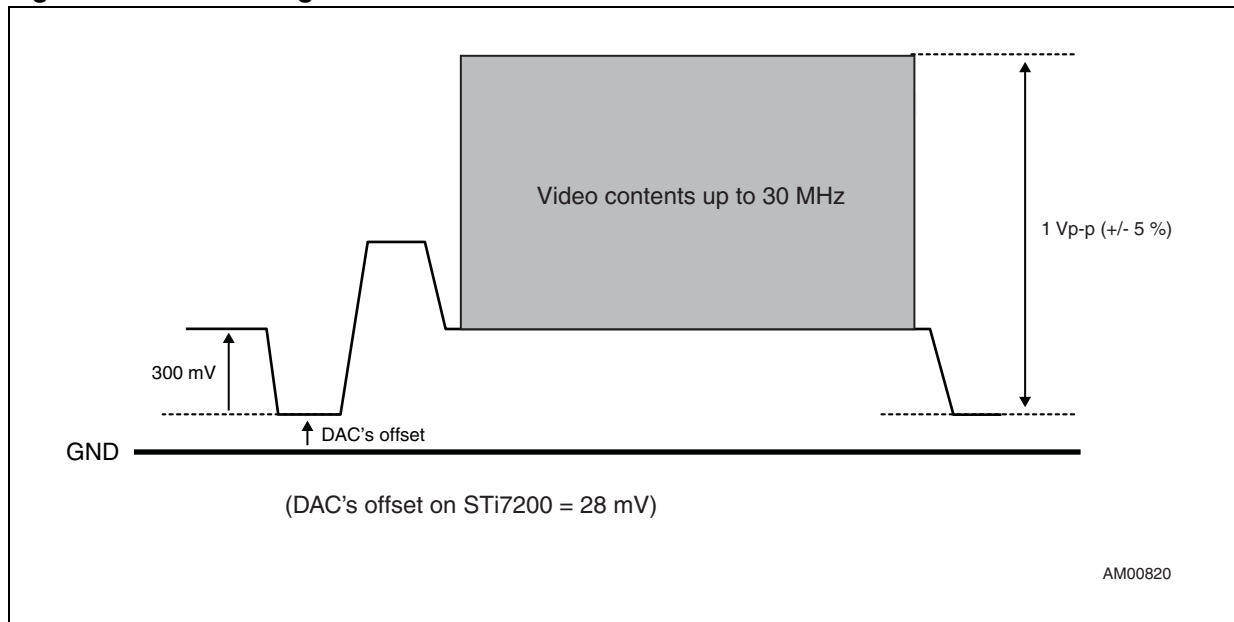

Figure 32. Standard video signal

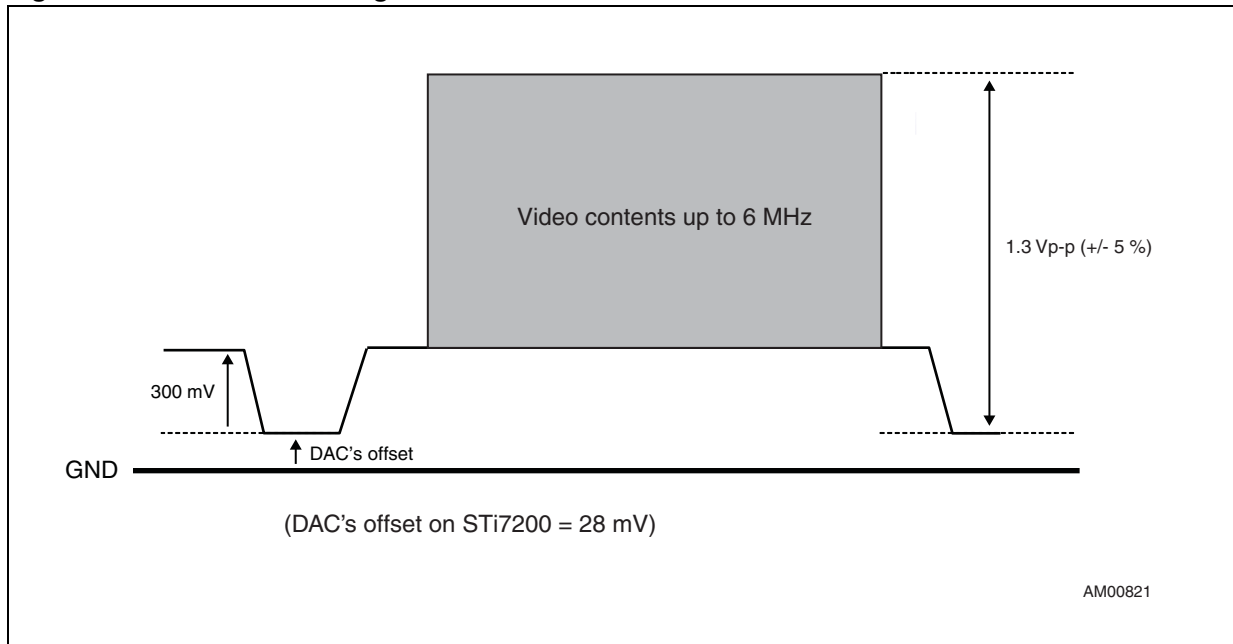
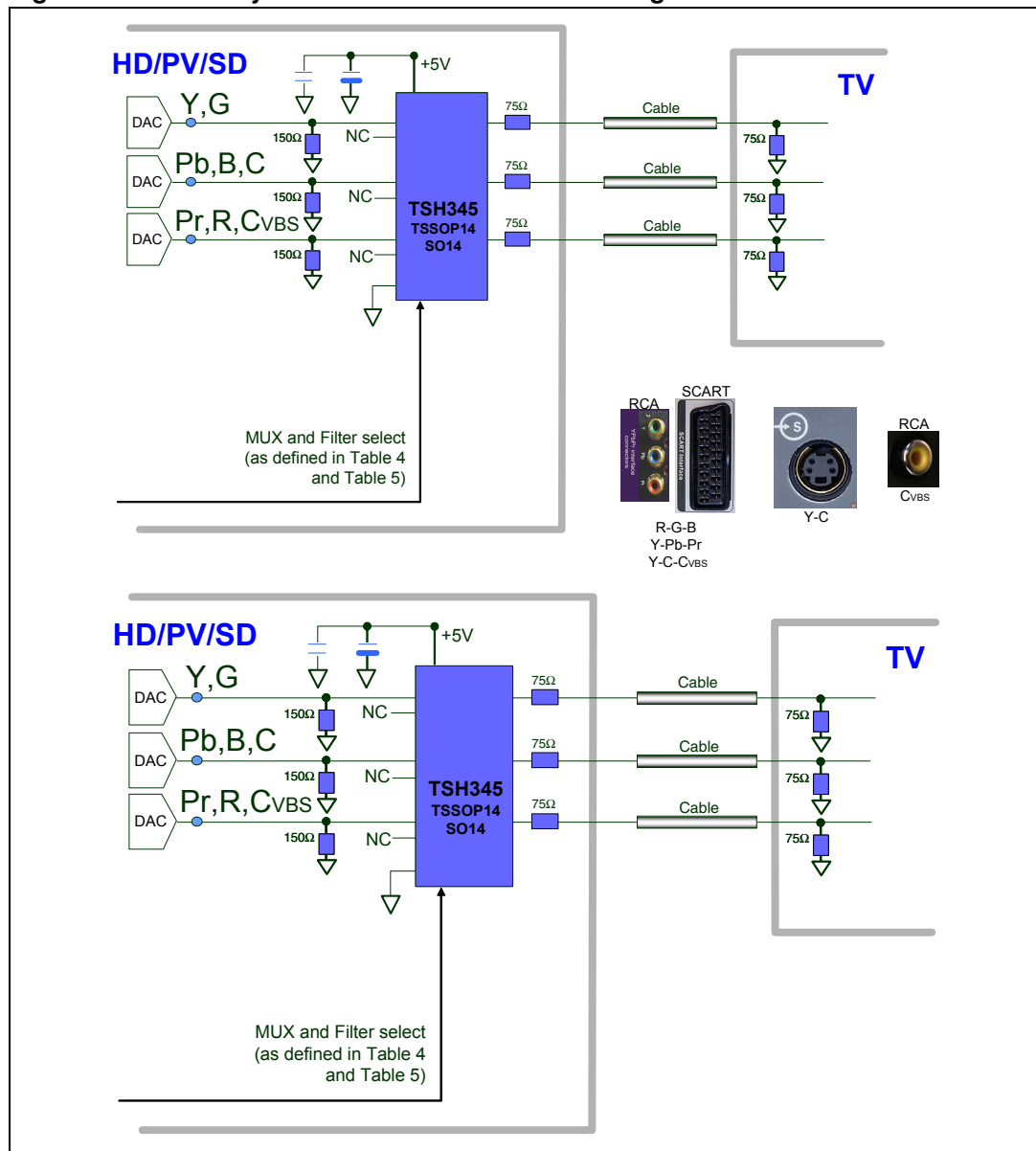

Figure 33. Flexibility of the TSH345 for SD and HD signals



The TSH345 is used to drive either high-definition video signals up to 30 MHz or progressive and interlaced standard definition video signals on 75-Ω video lines. It can drive a large panel of signals such as YC and CVBS, YUV, YPbPr and RGB, where the bottom of the signal (the synchronization tip in the case of Y and CVBS signals) is close to zero volts. An internal input DC value is added to the video signal in order to shift the bottom from GND.

The shift is not based on the average of the signal, but is an analog summation of a DC component to the video signal. Therefore, no input capacitors are required, which provides a real advantage in terms of cost and board space.

Under these conditions, it is possible to drive the signal in single supply without any saturation of the driver against the lower rail.

Since half of the signal is lost through output impedance matching, in order to properly drive the video line the shifted signal is multiplied by a gain of 2 or +6 dB.

3.1 Output capacitor

The output can be either DC-coupled or AC-coupled. The output can be directly connected to the line via a 75-Ω resistor (see [Figure 34](#)), or an output capacitor can be used to remove any DC components in the load. Assuming the load is 150 Ω, a coupling capacitor of 220 μF can be used to provide a very low cut-off frequency close to 5 Hz (see [Figure 35](#)).

Figure 34. DC output coupling for SD, PV and HD

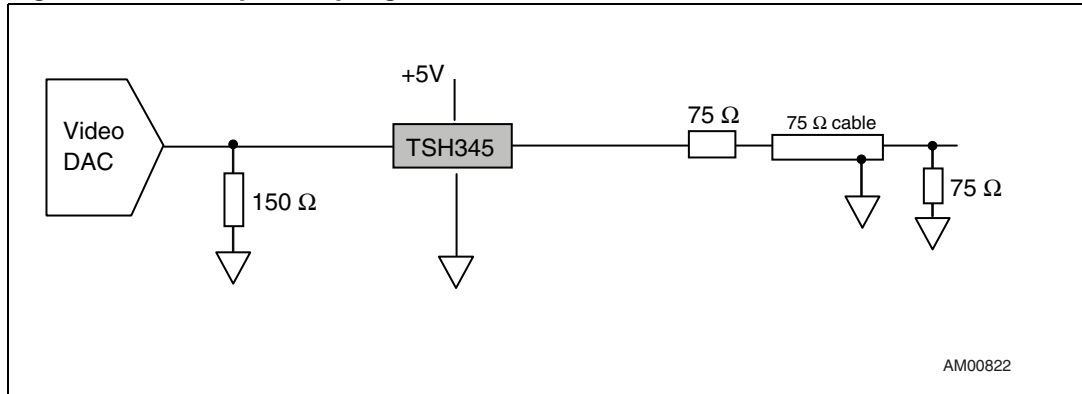
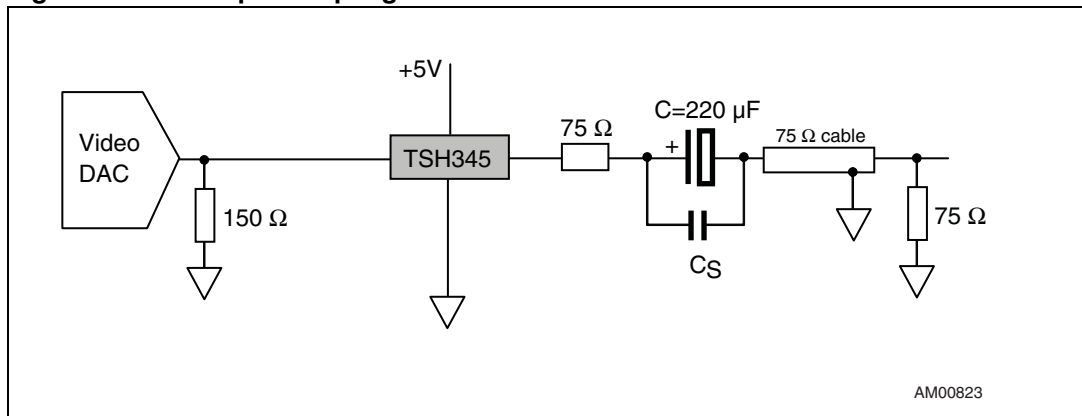

Figure 35. AC output coupling



1. C_S is 100 nF used to decrease the parasitic components of C in high frequencies. It is preferable to limit the use of this output AC-coupling to the standard definition only.
2. The 75-Ω resistor must be as close as possible to the output of the driver to minimize the effect of parasitic capacitance.

4 Package information

In order to meet environmental requirements, ST offers these devices in different grades of ECOPACK[®] packages, depending on their level of environmental compliance. ECOPACK[®] specifications, grade definitions and product status are available at: www.st.com. ECOPACK[®] is an ST trademark.

4.1 SO-14 package information

Figure 36. SO-14 package mechanical drawing

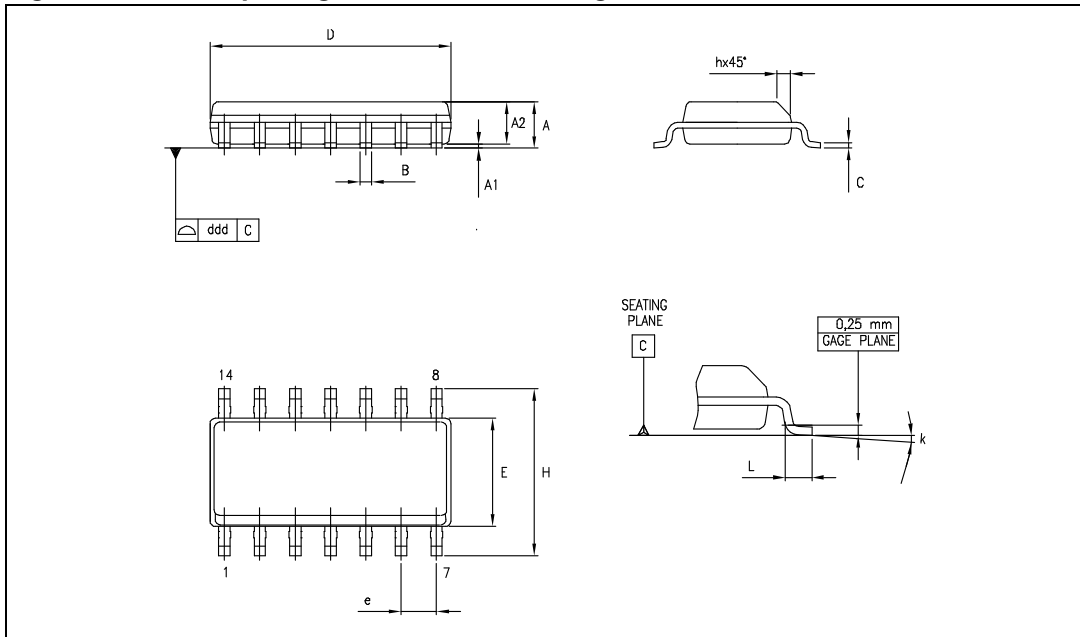

Table 6. SO-14 package mechanical data

Ref.	Dimensions					
	Millimeters			Inches		
	Min.	Typ.	Max.	Min.	Typ.	Max.
A	1.35		1.75	0.05		0.068
A1	0.10		0.25	0.004		0.009
A2	1.10		1.65	0.04		0.06
B	0.33		0.51	0.01		0.02
C	0.19		0.25	0.007		0.009
D	8.55		8.75	0.33		0.34
E	3.80		4.0	0.15		0.15
e		1.27			0.05	
H	5.80		6.20	0.22		0.24
h	0.25		0.50	0.009		0.02
L	0.40		1.27	0.015		0.05
k	8° (max.)					
ddd			0.10			0.004

Note: D and F dimensions do not include mold flash or protrusions. Mold flash or protrusions must not exceed 0.15 mm.

4.2 TSSOP14 package information

Figure 37. TSSOP14 package mechanical drawing

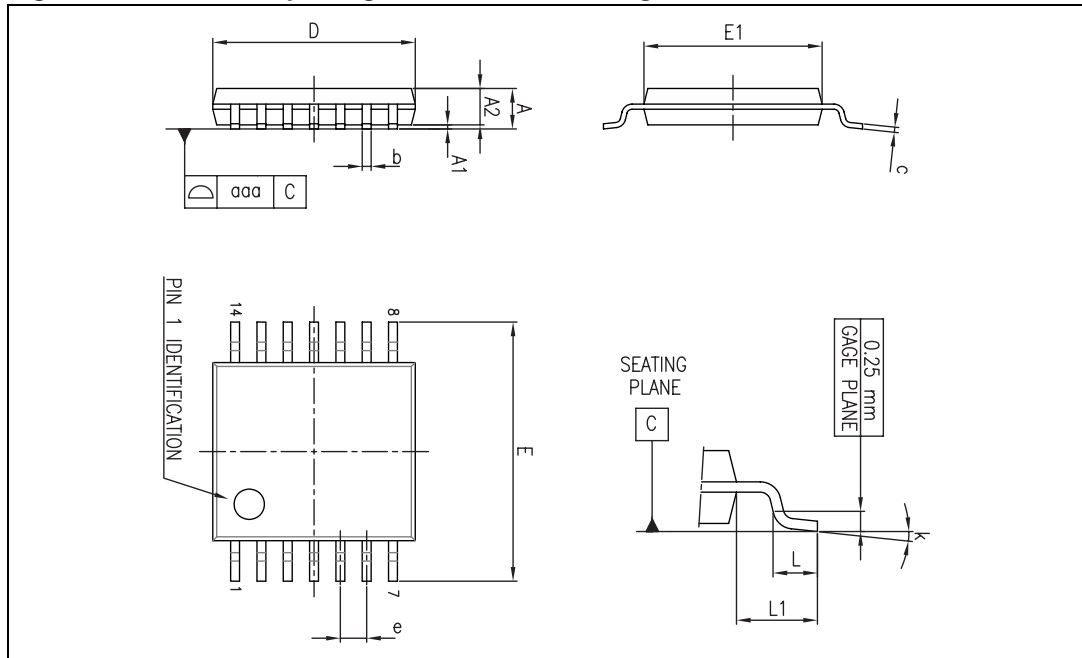

Table 7. TSSOP14 package mechanical data

Ref.	Dimensions					
	Millimeters			Inches		
	Min.	Typ.	Max.	Min.	Typ.	Max.
A			1.20			0.047
A1	0.05		0.15	0.002	0.004	0.006
A2	0.80	1.00	1.05	0.031	0.039	0.041
b	0.19		0.30	0.007		0.012
c	0.09		0.20	0.004		0.0089
D	4.90	5.00	5.10	0.193	0.197	0.201
E	6.20	6.40	6.60	0.244	0.252	0.260
E1	4.30	4.40	4.50	0.169	0.173	0.176
e		0.65			0.0256	
L	0.45	0.60	0.75	0.018	0.024	0.030
L1		1.00			0.039	
k	0°		8°	0°		8°
aaa			0.10			0.004

5 Ordering information

Table 8. Order codes

Part number	Temperature range	Package	Packing	Marking
TSH345ID	-40°C to +85°C	SO-14	Tube	TSH345I
TSH345IDT			Tape & reel	TSH345I
TSH345IPT		TSSOP14	Tape & reel	TSH345I

6 Revision history

Table 9. Document revision history

Date	Revision	Changes
29-May-2007	1	Initial release.
18-Dec-2008	2	Added curves in Chapter 2: Electrical characteristics . Added all test limits in Chapter Table 3 .

Please Read Carefully:

Information in this document is provided solely in connection with ST products. STMicroelectronics NV and its subsidiaries ("ST") reserve the right to make changes, corrections, modifications or improvements, to this document, and the products and services described herein at any time, without notice.

All ST products are sold pursuant to ST's terms and conditions of sale.

Purchasers are solely responsible for the choice, selection and use of the ST products and services described herein, and ST assumes no liability whatsoever relating to the choice, selection or use of the ST products and services described herein.

No license, express or implied, by estoppel or otherwise, to any intellectual property rights is granted under this document. If any part of this document refers to any third party products or services it shall not be deemed a license grant by ST for the use of such third party products or services, or any intellectual property contained therein or considered as a warranty covering the use in any manner whatsoever of such third party products or services or any intellectual property contained therein.

UNLESS OTHERWISE SET FORTH IN ST'S TERMS AND CONDITIONS OF SALE ST DISCLAIMS ANY EXPRESS OR IMPLIED WARRANTY WITH RESPECT TO THE USE AND/OR SALE OF ST PRODUCTS INCLUDING WITHOUT LIMITATION IMPLIED WARRANTIES OF MERCHANTABILITY, FITNESS FOR A PARTICULAR PURPOSE (AND THEIR EQUIVALENTS UNDER THE LAWS OF ANY JURISDICTION), OR INFRINGEMENT OF ANY PATENT, COPYRIGHT OR OTHER INTELLECTUAL PROPERTY RIGHT.

UNLESS EXPRESSLY APPROVED IN WRITING BY AN AUTHORIZED ST REPRESENTATIVE, ST PRODUCTS ARE NOT RECOMMENDED, AUTHORIZED OR WARRANTED FOR USE IN MILITARY, AIR CRAFT, SPACE, LIFE SAVING, OR LIFE SUSTAINING APPLICATIONS, NOR IN PRODUCTS OR SYSTEMS WHERE FAILURE OR MALFUNCTION MAY RESULT IN PERSONAL INJURY, DEATH, OR SEVERE PROPERTY OR ENVIRONMENTAL DAMAGE. ST PRODUCTS WHICH ARE NOT SPECIFIED AS "AUTOMOTIVE GRADE" MAY ONLY BE USED IN AUTOMOTIVE APPLICATIONS AT USER'S OWN RISK.

Resale of ST products with provisions different from the statements and/or technical features set forth in this document shall immediately void any warranty granted by ST for the ST product or service described herein and shall not create or extend in any manner whatsoever, any liability of ST.

ST and the ST logo are trademarks or registered trademarks of ST in various countries.

Information in this document supersedes and replaces all information previously supplied.

The ST logo is a registered trademark of STMicroelectronics. All other names are the property of their respective owners.

© 2008 STMicroelectronics - All rights reserved

STMicroelectronics group of companies

Australia - Belgium - Brazil - Canada - China - Czech Republic - Finland - France - Germany - Hong Kong - India - Israel - Italy - Japan - Malaysia - Malta - Morocco - Singapore - Spain - Sweden - Switzerland - United Kingdom - United States of America

www.st.com



X-ON Electronics

Largest Supplier of Electrical and Electronic Components

Click to view similar products for [Video Amplifiers](#) category:

Click to view products by [STMicroelectronics](#) manufacturer:

Other Similar products are found below :

[LT1193CN8](#) [LT6552IDD#PBF](#) [ADA4856-3YCPZ-R7](#) [LT1253CN8#PBF](#) [ADA4859-3ACPZ-R7](#) [AD829SQ/883B](#) [AD8001ANZ](#) [AD8001AQ](#)
[AD8001AR](#) [AD8001ARTZ-REEL7](#) [AD8002ARMZ](#) [AD8011ANZ](#) [AD8072ARMZ](#) [AD8072JNZ](#) [AD810ANZ](#) [AD811ANZ](#) [AD8123ACPZ](#)
[AD8123ACPZ-R7](#) [AD812ANZ](#) [AD813ANZ](#) [AD8141ACPZ-R2](#) [AD818ANZ](#) [AD828ANZ](#) [AD829JNZ](#) [AD8134ACPZ-R2](#) [AD8134ACPZ-](#)
[REEL7](#) [ADA4310-1ARHZ](#) [ADA4310-1ARHZ-R7](#) [ADA4433-1BCPZ-R2](#) [ADA4433-1BCPZ-R7](#) [ADA4433-1WBCPZ-R7](#) [ADA4853-](#)
[2YCPZ-R2](#) [ADA4853-3YRUZ](#) [ADA4859-3ACPZ-R2](#) [ADA4310-1ACPZ-R2](#) [AD8073JRZ](#) [AD8023ARZ](#) [AD813ARZ-14](#) [AD8013ARZ-14](#)
[AD813ARZ-14-REEL7](#) [AD8145YCPZ-R7](#) [AD8143ACPZ-REEL7](#) [AD8372ACPZ-R7](#) [ADA4853-2YCPZ-RL7](#) [AD8002ARZ-R7](#) [AD8072JRZ](#)
[AD8001ARZ](#) [AD8002ARZ](#) [AD812ARZ-REEL7](#) [AD828ARZ](#)