

Dual Comparator and Voltage Reference

COMPARATOR

- Low supply current (1.1ma) independent of supply voltage
- Low input bias current: 25nA typ
- Low input offset voltage: $\pm 1\text{mV}$ typ
- Input common-mode voltage range includes ground
- Low output saturation voltage: 250mV typ ($I_o = 4\text{mA}$)
- Differential input voltage range equal to the supply voltage
- Wide power supply range: $\pm 1\text{V}$ to $\pm 18\text{V}$

VOLTAGE REFERENCE

- Fixed V_{ref} to 2.5V
- 0.4% and 1% voltage precision
- Sink current capability: 1 to 100mA

DESCRIPTION

The TSM109 is a monolithic IC that includes two comparators and a shunt voltage reference. This device offers space and cost savings in many applications including power supply management or data acquisition systems.

Package Reference

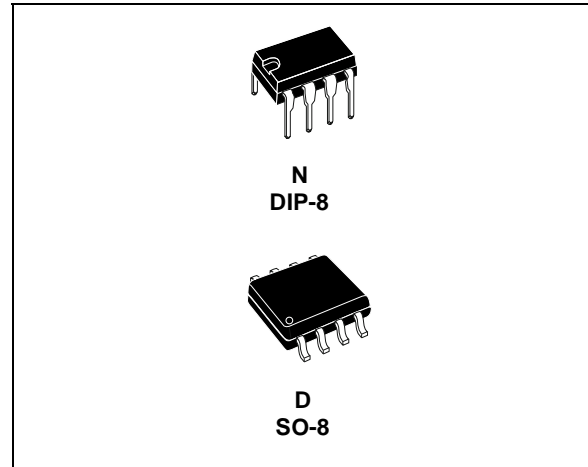

ORDER CODE

| Part Number | Temperature Range | Package | |
|-------------|-------------------|---------|---|
| | | N | D |
| TSM109 | -40°C, +105°C | • | • |
| TSM109A | -40°C, +105°C | • | • |

Note: N = Dual in Line Package (DIP)
 D = Small Outline Package (SO) - also available in Tape & Reel (DT)

PIN CONNECTIONS (top view)

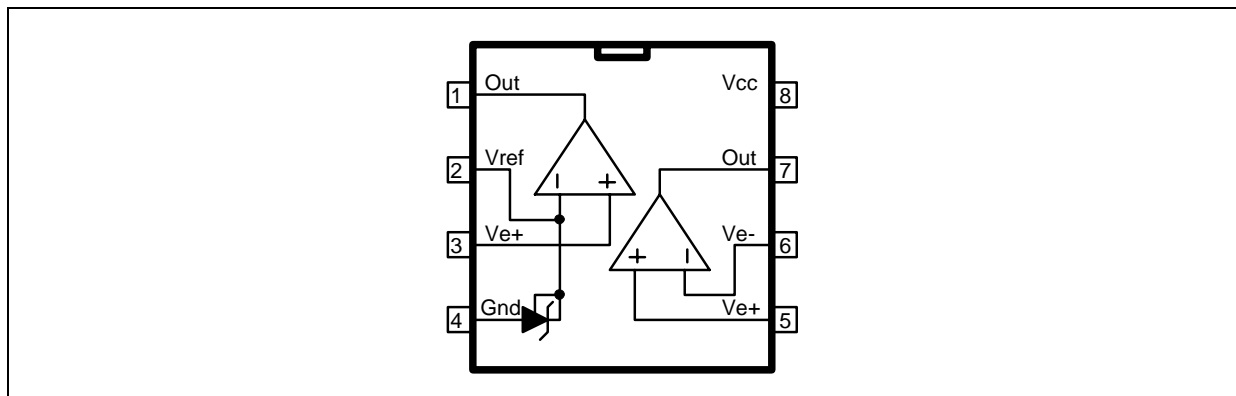

1 ABSOLUTE MAXIMUM RATINGS

| Symbol | Parameter | Value | Unit |
|-------------------|---|------------------------------|------|
| V _{CC} | Supply voltage | 36 | V |
| V _{in} | Input Voltage | -0.3 to V _{CC} +0.3 | V |
| I _k | Continuous Cathode current range | -100 to 150 | mA |
| T _j | Maximum Junction Temperature | 150 | °C |
| R _{thja} | Thermal Resistance Junction to Ambient (SO package) | 175 | °C/W |
| ESD | Electrostatic Discharge Protection | 1.5 | kV |

OPERATING CONDITIONS

| Symbol | Parameter | Value | Unit |
|-------------------|-------------------------|------------|------|
| V _{CC} | DC Supply Conditions | 2 to 36 | V |
| T _{oper} | Operational temperature | -40 to 105 | °C |

ELECTRICAL CHARACTERISTICS

V_{CC}⁺ = 5V, V_{CC}⁻ = 0V, T_{amb} = 25°C (unless otherwise specified)

| Symbol | Parameter | Min | Typ | Max | Unit |
|-----------------|---|-----|----------|----------|------|
| I _{CC} | Total Supply Current, excluding current in the Voltage Reference V _{CC} = +5V, no load V _{CC} = +30V, no load | | 0.4 1 | 1 2.5 | mA |

2 ELECTRICAL CHARACTERISTICS

COMPARATOR (independent comparator)

$V_{CC^+} = +5V$, $V_{CC^-} = GND$, $T_{amb} = +25^{\circ}C$ (unless otherwise specified)

| Symbol | Parameter | TSM109 | | | Unit |
|------------|--|--------|------|------------------------------------|---------------|
| | | Min. | Typ. | Max. | |
| V_{io} | Input Offset Voltage - note ¹ $T_{amb} = +25^{\circ}C$ $T_{min} \leq T_{amb} \leq T_{max}$ | | 1 | 5 9 | mV |
| I_{io} | Input Offset Current $T_{amb} = +25^{\circ}C$ $T_{min} \leq T_{amb} \leq T_{max}$ | | 3 | 25 100 | nA |
| I_{ib} | Input Bias Current (I^+ or I^-) - note ² $T_{amb} = +25^{\circ}C$ $T_{min} \leq T_{amb} \leq T_{max}$ | | 25 | 250 400 | nA |
| A_{vd} | Large Signal Voltage Gain $V_{CC} = 15V$, $R_L = 15k\Omega$, $V_o = 1V$ to $11V$ | 50 | 200 | | V/mV |
| V_{icm} | Input Common Mode Voltage Range - note ³ $V_{CC} = 30V$ $T_{amb} = +25^{\circ}C$ $T_{min} \leq T_{amb} \leq T_{max}$ | 0 0 | | $V_{CC^+} - 1.5$ $V_{CC^+} - 2$ | V |
| V_{id} | Differential Input Voltage - note ⁴ | | | V_{CC^+} | |
| V_{OL} | Low Level Output Voltage $V_{id} = -1V$, $I_{sink} = 4mA$ $T_{amb} = +25^{\circ}C$ $T_{min} \leq T_{amb} \leq T_{max}$ | | 250 | 400 700 | mV |
| I_{OH} | High Level Output Current ($V_{id} = 1V$) $V_{CC} = V_o = 30V$ $T_{amb} = +25^{\circ}C$ $T_{min} \leq T_{amb} \leq T_{max}$ | | 30 | 150 1 | nA μA |
| I_{sink} | Output Sink Current $V_{id} = 1V$, $V_o = 1.5V$ | 10 | 20 | | mA |
| t_{re} | Response Time - note ⁵ $R_L = 5.1k\Omega$ connected to V_{CC^+} | | 1.3 | | μs |
| t_{rel} | Large Signal Response Time $R_L = 5.1k\Omega$ connected to V_{CC^+} , $e_1 = TTL$, $V_{(ref)} = +1.4V$ | | 300 | | ns |

- 1) At output switch point, $V_o \approx 1.4V$, $R_s = 0$ with V_{CC^+} from 5V to 30V, and over the full common-mode range (0V to $V_{CC^+} - 1.5V$).
- 2) The direction of the input current is out of the IC due to the PNP input stage. This current is essentially constant, independent of the state of the output, so no loading charge exists on the reference of input lines.
- 3) The input common-mode voltage of either input signal voltage should not be allowed to go negative by more than 0.3V. The upper end of the common-mode voltage range is $V_{CC^+} - 1.5V$.
- 4) Positive voltage excursions of one input may exceed the power supply level. As long as the other input voltage remains within the common-mode range, the comparator will provide an appropriate output state. The low input voltage state must not be less than -0.3V (or 0.3V below the negative power supply, if used).
- 5) The response time specified is for a 100mV input step with 5mV overdrive. For larger overdrive signals, 300ns can be obtained

COMPARATOR (comparator with inverting input connected to the internal Vref)) $V_{CC}^+ = +5V$, $V_{CC}^- = GND$, $T_{amb} = +25^\circ C$ (unless otherwise specified)

| Symbol | Parameter | TSM109 | | | Unit |
|------------|---|--------|------|---------------------|---------------|
| | | Min. | Typ. | Max. | |
| V_{io} | Input Offset Voltage - note ¹ $T_{amb} = +25^\circ C$ $T_{min} \leq T_{amb} \leq T_{max}$ | | 1 | 5 9 | mV |
| I_{ib} | Input Bias Current for positive input note ² $T_{amb} = +25^\circ C$ $T_{min} \leq T_{amb} \leq T_{max}$ | | 25 | 250 400 | nA |
| A_{vd} | Large Signal Voltage Gain $V_{CC} = 15V$, $R_L = 15k\Omega$, $V_o = 1V$ to $11V$ | 50 | 200 | | V/mV |
| V_{id} | Differential Input Voltage -note | | | V_{CC}^+ -2.5V | V |
| V_{OL} | Low Level Output Voltage $V_{id} = -1V$, $I_{sink} = 4mA$ $T_{amb} = +25^\circ C$ $T_{min} \leq T_{amb} \leq T_{max}$ | | 250 | 400 700 | mV |
| I_{OH} | High Level Output Current ($V_{id} = 1V$) $V_{CC} = V_o = 30V$ $T_{amb} = +25^\circ C$ $T_{min} \leq T_{amb} \leq T_{max}$ | | 30 | 150 1 | nA μA |
| I_{sink} | Output Sink Current $V_{id} = 1V$, $V_o = 1.5V$ | 10 | 20 | | mA |
| t_{re} | Response Time - note ³ $R_L = 5.1k\Omega$ connected to V_{CC}^+ | | 1.3 | | μs |
| t_{rel} | Large Signal Response Time $R_L = 5.1k\Omega$ connected to V_{CC}^+ , $e_1 = TTL$, $V_{(ref)} = +1.4V$ | | 300 | | ns |

- 1) At output switch point, $V_o \approx 1.4V$, $R_s = 0$ with V_{CC}^+ from $5V$ to $30V$, and over the full common-mode range ($0V$ to $V_{CC}^+ - 1.5V$).
- 2) The direction of the input current is out of the IC due to the PNP input stage. This current is essentially constant, independent of the state of the output, so no loading charge exists on the reference of input lines.
- 3) The response time specified is for a $100mV$ input step with $5mV$ overdrive. For larger overdrive signals, $300ns$ can be obtained.

ELECTRICAL CHARACTERISTICS

VOLTAGE REFERENCE

| Symbol | Conditions | Value | Unit |
|--------|-----------------|----------|------|
| I_K | Cathode Current | 1 to 100 | mA |

$T_{amb} = 25^\circ\text{C}$ (unless otherwise specified)

| Symbol | Parameter | TSM109A | | | TSM109 | | | Unit |
|---|---|---------------|----------|---------------|---------------|----------|---------------|-----------------------|
| | | Min. | Typ. | Max. | Min. | Typ. | Max. | |
| V_{ref} | Reference Input Voltage, $I_K = 10\text{ mA}$ $T_{amb} = 25^\circ\text{C}$ $T_{min} \leq T_{amb} \leq T_{max}$ | 2.490 2.48 | 2.500 | 2.510 2.52 | 2.475 2.45 | 2.500 | 2.525 2.55 | V |
| ΔV_{ref} | Reference Input Voltage Deviation Over Temperature Range $I_K = 10\text{ mA}$ $T_{min} \leq T_{amb} \leq T_{max}$ | | 7 | 30 | | 7 | 30 | mV |
| $\frac{\Delta V_{ref}}{V_{ref} \Delta T}$ | Temperature Coefficient of Reference Input Voltage $I_K = 10\text{ mA}$, $T_{min} \leq T_{amb} \leq T_{max}$ | | ± 13 | ± 90 | | ± 13 | ± 90 | ppm/ $^\circ\text{C}$ |
| I_{min} | Minimum Cathode Current for Regulation | | 0.5 | 1 | | 0.5 | 1 | mA |
| $ Z_{Vref} $ | Dynamic Impedance - note ¹ ΔV_{ref} , $\Delta I_K = 1\text{ to }100\text{ mA}$, $f < 1\text{ KHz}$ | | 0.3 | 0.65 | | 0.3 | 0.65 | Ω |

1) The dynamic impedance is defined as $|Z_{Vref}| = \Delta V_{Vref} / \Delta I_K$

3 PACKAGE MECHANICAL DATA

| Plastic DIP-8 MECHANICAL DATA | | | | | | |
|-------------------------------|------|------|------|-------|-------|-------|
| DIM. | mm. | | | inch | | |
| | MIN. | TYP. | MAX. | MIN. | TYP. | MAX. |
| A | | 3.3 | | | 0.130 | |
| a1 | 0.7 | | | 0.028 | | |
| B | 1.39 | | 1.65 | 0.055 | | 0.065 |
| B1 | 0.91 | | 1.04 | 0.036 | | 0.041 |
| b | | 0.5 | | | 0.020 | |
| b1 | 0.38 | | 0.5 | 0.015 | | 0.020 |
| D | | | 9.8 | | | 0.386 |
| E | | 8.8 | | | 0.346 | |
| e | | 2.54 | | | 0.100 | |
| e3 | | 7.62 | | | 0.300 | |
| e4 | | 7.62 | | | 0.300 | |
| F | | | 7.1 | | | 0.280 |
| l | | | 4.8 | | | 0.189 |
| L | | 3.3 | | | 0.130 | |
| Z | 0.44 | | 1.6 | 0.017 | | 0.063 |

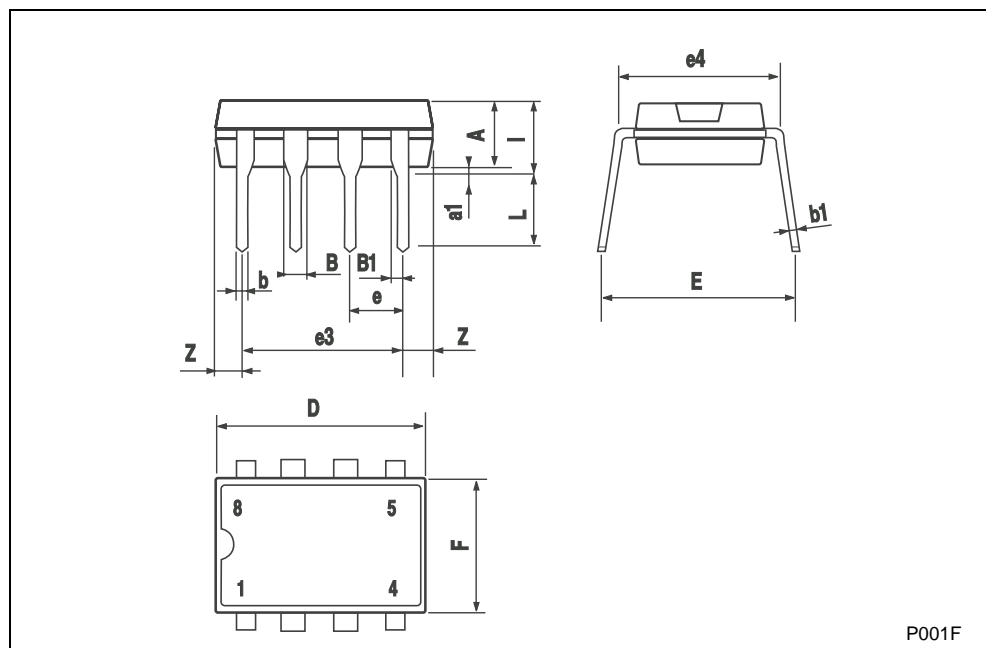

PACKAGE MECHANICAL DATA

| SO-8 MECHANICAL DATA | | | | | | |
|----------------------|-----------|------|------|-------|-------|-------|
| DIM. | mm. | | | inch | | |
| | MIN. | TYP. | MAX. | MIN. | TYP. | MAX. |
| A | 1.35 | | 1.75 | 0.053 | | 0.069 |
| A1 | 0.10 | | 0.25 | 0.04 | | 0.010 |
| A2 | 1.10 | | 1.65 | 0.043 | | 0.065 |
| B | 0.33 | | 0.51 | 0.013 | | 0.020 |
| C | 0.19 | | 0.25 | 0.007 | | 0.010 |
| D | 4.80 | | 5.00 | 0.189 | | 0.197 |
| E | 3.80 | | 4.00 | 0.150 | | 0.157 |
| e | | 1.27 | | | 0.050 | |
| H | 5.80 | | 6.20 | 0.228 | | 0.244 |
| h | 0.25 | | 0.50 | 0.010 | | 0.020 |
| L | 0.40 | | 1.27 | 0.016 | | 0.050 |
| k | 8° (max.) | | | | | |
| ddd | | | 0.1 | | | 0.04 |

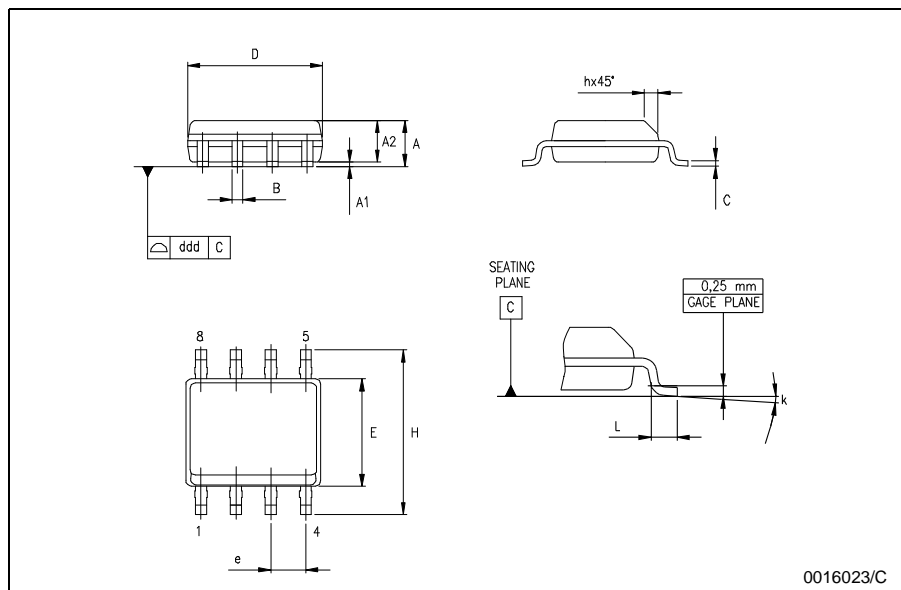

Information furnished is believed to be accurate and reliable. However, STMicroelectronics assumes no responsibility for the consequences of use of such information nor for any infringement of patents or other rights of third parties which may result from its use. No license is granted by implication or otherwise under any patent or patent rights of STMicroelectronics. Specifications mentioned in this publication are subject to change without notice. This publication supersedes and replaces all information previously supplied. STMicroelectronics products are not authorized for use as critical components in life support devices or systems without express written approval of STMicroelectronics.

The ST logo is a registered trademark of STMicroelectronics
 All other names are the property of their respective owners.

© 2004 STMicroelectronics - All Rights Reserved

STMicroelectronics GROUP OF COMPANIES

Australia - Belgium - Brazil - Canada - China - Czech Republic - Finland - France - Germany
 Hong Kong - India - Israel - Italy - Japan - Malaysia - Malta - Morocco - Singapore - Spain
 Sweden - Switzerland - United Kingdom - United States

<http://www.st.com>



STMicroelectronics

[About ST](#) [Products](#) [Applications](#) [Support](#) [Buy](#) [News & Events](#) [ST Worldwide](#)



SEARCH



Part Number Search

Search For Part #:

TSM109AIDT

Example: [*74*00*](#)

Matching Documents: 1 - 1 of 1

| Generic Part Number(s) | Orderable Part Number(s) | Status | Product Page/ Datasheet | Description |
|------------------------|----------------------------|--------|---|--|
| TSM109 | TSM109AIDT | Active |   | DUAL COMPARATOR AND VOLTAGE REFERENCE Power Management AC-DC Conversion Voltage |

Search time: 0.074s

STMicroelectronics

[About ST](#) [Products](#) [Applications](#) [Support](#) [Buy](#) [News & Events](#) [ST Worldwide](#)



SEARCH



Part Number Search

Search For Part #:

TSM109AID

Example: [*74*00*](#)

Matching Documents: 1 - 1 of 1

| Generic Part Number(s) | Orderable Part Number(s) | Status | Product Page/ Datasheet | Description |
|------------------------|---|------------------|---|--|
| TSM109 | TSM109AID TSM109AIDT | Active Active |   | DUAL COMPARATOR AND VOLTAGE REFERENCE Power Management AC-DC Conversion Voltage |

Search time: 0.073s

STMicroelectronics

[About ST](#) [Products](#) [Applications](#) [Support](#) [Buy](#) [News & Events](#) [ST Worldwide](#)



SEARCH



Part Number Search

Search For Part #:

TSM109AIN

Example: [*74*00*](#)

Matching Documents: 1 - 1 of 1

| Generic Part Number(s) | Orderable Part Number(s) | Status | Product Page/ Datasheet | Description |
|------------------------|---------------------------|--------|---|--|
| TSM109 | TSM109AIN | NRND |   | DUAL COMPARATOR AND VOLTAGE REFERENCE Power Management AC-DC Conversion Voltage |

Search time: 0.074s

STMicroelectronics

[About ST](#) [Products](#) [Applications](#) [Support](#) [Buy](#) [News & Events](#) [ST Worldwide](#)



SEARCH



Part Number Search

Search For Part #:

TSM109IDT

Example: [*74*00*](#)

Matching Documents: 1 - 1 of 1

| Generic Part Number(s) | Orderable Part Number(s) | Status | Product Page/ Datasheet | Description |
|------------------------|---------------------------|--------|---|--|
| TSM109 | TSM109IDT | Active |   | DUAL COMPARATOR AND VOLTAGE REFERENCE Power Management AC-DC Conversion Voltage |

Search time: 0.074s





Part Number Search

Search For Part #:

TSM109ID

Example: [*74*00*](#)

Matching Documents: 1 - 1 of 1

| Generic Part Number(s) | Orderable Part Number(s) | Status | Product Page/ Datasheet | Description |
|------------------------|---|------------------|---|--|
| TSM109 | TSM109ID TSM109IDT | Active Active |   | DUAL COMPARATOR AND VOLTAGE REFERENCE Power Management AC-DC Conversion Voltage |

Search time: 0.074s

STMicroelectronics

[About ST](#) [Products](#) [Applications](#) [Support](#) [Buy](#) [News & Events](#) [ST Worldwide](#)



SEARCH



Part Number Search

Search For Part #:

TSM109IN

Example: [*74*00*](#)

Matching Documents: 1 - 1 of 1

| Generic Part Number(s) | Orderable Part Number(s) | Status | Product Page/ Datasheet | Description |
|------------------------|--------------------------|--------|---|--|
| TSM109 | TSM109IN | NRND |   | DUAL COMPARATOR AND VOLTAGE REFERENCE Power Management AC-DC Conversion Voltage |

Search time: 0.074s

X-ON Electronics

Largest Supplier of Electrical and Electronic Components

Click to view similar products for [Analog Comparators](#) category:

Click to view products by [STMicroelectronics](#) manufacturer:

Other Similar products are found below :

[SC2903VDR2G](#) [LM2901SNG](#) [LM339SNG](#) [55122](#) [5962-8757203IA](#) [NTE911](#) [5962-8751601DA](#) [LM339EDR2G](#) [NTE922](#) [SC2901DR2G](#)
[LM2903M/TR](#) [LM2903F-E2](#) [MCP6544-EP](#) [LM2901EDR2G](#) [TS391SN2T1G](#) [LM111JG](#) [LM239APT](#) [HMC675LC3CTR](#) [5962-8765801PA](#)
[MAX9024AUD+](#) [LT6700HVIS6-2#TRMPBF](#) [5962-8765902CA](#) [ADCMP394ARZ-RL7](#) [LM339AMX](#) [LTC1440IMS8#PBF](#) [AZV331KSTR-](#)
[G1](#) [LTC1841IS8#PBF](#) [LTC1440CN8#PBF](#) [LTC1542CS8#PBF](#) [LTC1445CS#PBF](#) [TL331VSN4T3G](#) [LT6700IDCB-1#TRMPBF](#)
[LTC1042CN8#PBF](#) [LTC1540CMS8#PBF](#) [LT6703CDC-2#TRMPBF](#) [ADCMP607BCPZ-R7](#) [LT1720CDD#PBF](#) [LTC1040CN#PBF](#)
[LT6700MPDCB-1#TRMPBF](#) [LT6700IDCB-3#TRMPBF](#) [LTC1440IS8#PBF](#) [S-89431ACNC-HBVTFG](#) [CMP402GSZ-REEL](#) [NTE1718](#)
[NTE943](#) [NTE943M](#) [NTE943SM](#) [TA75S393F,LF\(T](#) [ALD2301APAL](#) [ALD2302APAL](#)