

## 16 MHz rail-to-rail CMOS 16 V operational amplifiers

Datasheet - production data

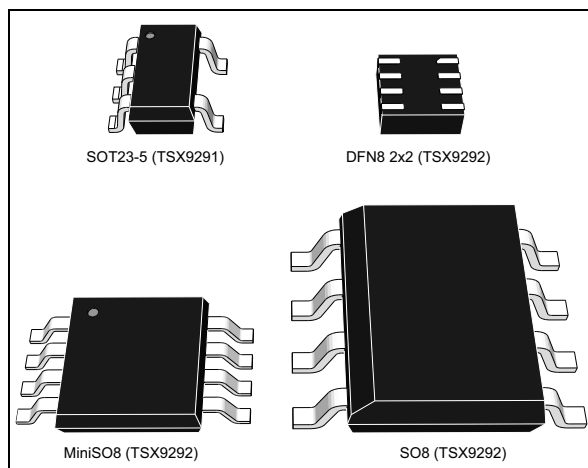

### Applications

- Communications
- Process control
- Active filtering
- Test equipment

### Description

The TSX9291 and TSX9292 operational amplifiers (op-amps) offer excellent AC characteristics such as 16 MHz gain bandwidth, 27 V/ $\mu$ s slew rate, and 0.0003 % THD+N. They are decompensated amplifiers which are stable when used with a gain higher than 2 or lower than -1. The rail-to-rail input and output capability of these devices operates on a wide supply voltage range of 4 V to 16 V. These last two features make the TSX929x series particularly well-adapted for a wide range of applications such as communications, I/V amplifiers for ADCs, and active filtering applications.

### Features

- Rail-to-rail input and output
- Wide supply voltage: 4 V - 16 V
- Gain bandwidth product: 16 MHz typ at 16 V
- Low power consumption: 2.8 mA typ at 16 V
- Slew rate: 27 V/ $\mu$ s
- Stable when used in gain configuration
- Low input bias current: 10 pA typ
- High tolerance to ESD: 4 kV HBM
- Extended temperature range: -40° C to +125° C
- Automotive qualification

Table 1. Device summary

	Single	Dual
Op-amp version	TSX9291	TSX9292

### Related products

- See the TSX5 series for low power features
- See the TSX6 series for micro power features
- See the TSX92 series for unity gain stability
- See the TSV9 series for lower voltage

# Contents

<b>1</b>	<b>Package pin connections</b> .....	<b>3</b>
<b>2</b>	<b>Absolute maximum ratings and operating conditions</b> .....	<b>4</b>
<b>3</b>	<b>Electrical characteristics</b> .....	<b>5</b>
<b>4</b>	<b>Application information</b> .....	<b>17</b>
4.1	Operating voltages .....	17
4.2	Rail-to-rail input .....	17
4.3	Input pin voltage range .....	17
4.4	Stability for gain = -1 .....	18
4.5	Input offset voltage drift over temperature .....	19
4.6	Long-term input offset voltage drift .....	20
4.7	Capacitive load .....	21
4.8	High side current sensing .....	23
4.9	High speed photodiode .....	24
<b>5</b>	<b>Package information</b> .....	<b>25</b>
5.1	SOT23-5 package mechanical data .....	26
5.2	DFN8 2x2 package information .....	27
5.3	MiniSO8 package information .....	28
5.4	SO8 package information .....	29
<b>6</b>	<b>Ordering information</b> .....	<b>30</b>
<b>7</b>	<b>Revision history</b> .....	<b>30</b>

# 1 Package pin connections

Figure 1. Pin connections (top view)

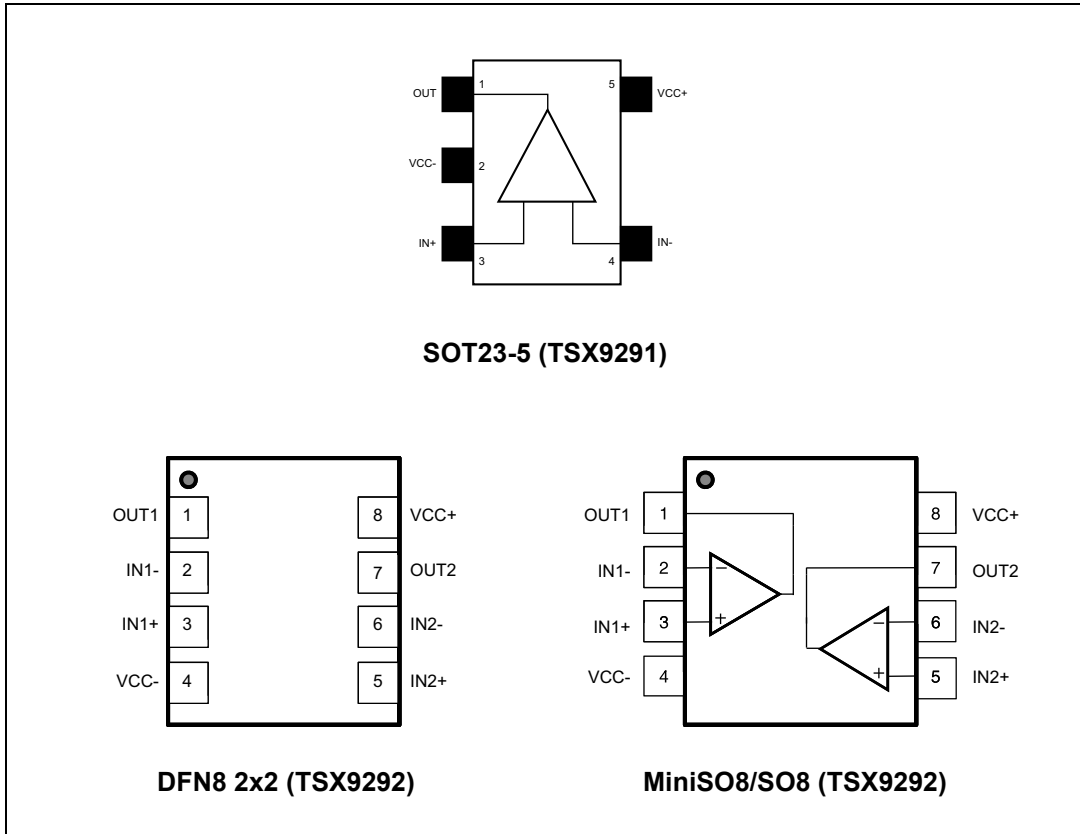

## 2 Absolute maximum ratings and operating conditions

**Table 2. Absolute maximum ratings (AMR)**

Symbol	Parameter	Value	Unit
$V_{CC}$	Supply voltage <sup>(1)</sup>	18	V
$V_{id}$	Differential input voltage <sup>(2)</sup>	$\pm V_{CC}$	mV
$V_{in}$	Input voltage	$V_{CC-} - 0.2$ to $V_{CC+} + 0.2$	V
$I_{in}$	Input current <sup>(3)</sup>	10	mA
$T_{stg}$	Storage temperature	-65 to +150	°C
$R_{thja}$	Thermal resistance junction to ambient <sup>(4)(5)</sup>		°C/W
	SOT23-5	250	
	DFN8 2x2	57	
	MiniSO8	190	
	SO8	125	
$T_j$	Maximum junction temperature	150	°C
ESD	HBM: human body model <sup>(6)</sup>	4000	V
	MM: machine model <sup>(7)</sup>	100	
	CDM: charged device model <sup>(8)</sup>	1500	
	Latch-up immunity	200	mA

1. All voltage values, except the differential voltage are with respect to network ground terminal.
2. The differential voltage is the non-inverting input terminal with respect to the inverting input terminal.
3. Input current must be limited by a resistor in series with the inputs.
4. Short-circuits can cause excessive heating and destructive dissipation.
5.  $R_{th}$  are typical values.
6. According to JEDEC standard JESD22-A114F
7. According to JEDEC standard JESD22-A115A
8. According to ANSI/ESD STM5.3.1

**Table 3. Operating conditions**

Symbol	Parameter	Value	Unit
$V_{CC}$	Supply voltage	4 to 16	V
$V_{icm}$	Common mode input voltage range	$V_{CC-} - 0.1$ to $V_{CC+} + 0.1$	
$T_{oper}$	Operating free air temperature range	-40 to +125	°C

### 3 Electrical characteristics

**Table 4. Electrical characteristics at  $V_{CC+} = +4.5\text{ V}$  with  $V_{CC-} = 0\text{ V}$ ,  $V_{icm} = V_{CC}/2$ ,  $T_{amb} = 25\text{ }^\circ\text{C}$ , and  $R_L = 10\text{ k}\Omega$  connected to  $V_{CC}/2$  (unless otherwise specified)**

Symbol	Parameter	Conditions	Min.	Typ.	Max.	Unit
$V_{io}$	Input offset voltage	$V_{icm} = 2\text{ V}$ $T_{min} < T_{op} < T_{max}$			4 5	mV
$\Delta V_{io}/\Delta T$	Input offset voltage drift			2	10	$\mu\text{V}/^\circ\text{C}$
$\Delta V_{io}$	Long-term input offset voltage drift <sup>(1)(2)</sup>	TSX9291 TSX9292		6 9		$\frac{\text{nV}}{\sqrt{\text{month}}}$
$I_{ib}$	Input bias current	$V_{out} = V_{CC}/2$ $T_{min} < T_{op} < T_{max}$		10	100 200	pA
$I_{io}$	Input offset current	$V_{out} = V_{CC}/2$ $T_{min} < T_{op} < T_{max}$		10	100 200	
$R_{IN}$	Input resistance			1		$\text{T}\Omega$
$C_{IN}$	Input capacitance			8		pF
CMR	Common mode rejection ratio $20\log(\Delta V_{ic}/\Delta V_{io})$	$V_{icm} = -0.1\text{ V to } 2\text{ V}$ , $V_{OUT} = V_{CC}/2$ $T_{min} < T_{op} < T_{max}$	61 59	82		dB
		$V_{icm} = -0.1\text{ V to } 4.6\text{ V}$ , $V_{OUT} = V_{CC}/2$ $T_{min} < T_{op} < T_{max}$	59 57	72		
$A_{vd}$	Large signal voltage gain	$R_L = 2\text{ k}\Omega$ , $V_{out} = 0.3\text{ V to } 4.2\text{ V}$ $T_{min} < T_{op} < T_{max}$	100 90	108		
		$R_L = 10\text{ k}\Omega$ , $V_{out} = 0.2\text{ V to } 4.3\text{ V}$ $T_{min} < T_{op} < T_{max}$	100 90	112		
$V_{OH}$	High level output voltage	$R_L = 2\text{ k}\Omega$ to $V_{CC}/2$ $T_{min} < T_{op} < T_{max}$		50	80 100	mV from $V_{CC+}$
		$R_L = 10\text{ k}\Omega$ to $V_{CC}/2$ $T_{min} < T_{op} < T_{max}$		10	16 20	
$V_{OL}$	Low level output voltage	$R_L = 2\text{ k}\Omega$ to $V_{CC}/2$ $T_{min} < T_{op} < T_{max}$		42	80 100	mV
		$R_L = 10\text{ k}\Omega$ to $V_{CC}/2$ $T_{min} < T_{op} < T_{max}$		9	16 20	
$I_{out}$	$I_{sink}$	$V_{out} = 4.5\text{ V}$ $T_{min} < T_{op} < T_{max}$	16 13	21		mA
	$I_{source}$	$V_{out} = 0\text{ V}$ $T_{min} < T_{op} < T_{max}$	16 13	21		
$I_{CC}$	Supply current (per amplifier)	No load, $V_{out} = V_{CC}/2$ $T_{min} < T_{op} < T_{max}$		2.9	3.4 3.5	
GBP	Gain bandwidth product	$R_L = 10\text{ k}\Omega$ , $C_L = 20\text{ pF}$ , $G = 20\text{ dB}$		15.6		MHz
$F_U$	Unity gain frequency	$R_L = 10\text{ k}\Omega$ , $C_L = 20\text{ pF}$		14.2		

**Table 4. Electrical characteristics at  $V_{CC+} = +4.5\text{ V}$  with  $V_{CC-} = 0\text{ V}$ ,  $V_{icm} = V_{CC}/2$ ,  $T_{amb} = 25\text{ }^{\circ}\text{C}$ , and  $R_L = 10\text{ k}\Omega$  connected to  $V_{CC}/2$  (unless otherwise specified) (continued)**

Symbol	Parameter	Conditions	Min.	Typ.	Max.	Unit
Gain	Minimum gain for stability	Phase margin = $60\text{ }^{\circ}$ , $R_g = R_f = 1\text{ k}\Omega$ $R_L = 10\text{ k}\Omega$ , $C_L = 20\text{ pF}$		-1 +2		
SR+	Positive slew rate	$A_v = +1$ , $V_{out} = 0.5\text{ to }4.0\text{ V}$ Measured between 10 % to 90 %		27		V/ $\mu\text{s}$
SR-	Negative slew rate	$A_v = +1$ , $V_{out} = 4.0\text{ to }0.5\text{ V}$ Measured between 90 % to 10 %		22		
$e_n$	Equivalent input noise voltage	$f = 10\text{ kHz}$ $f = 100\text{ kHz}$		17.9 12.9		$\frac{\text{nV}}{\sqrt{\text{Hz}}}$
$\int e_n$	Low-frequency peak-to-peak input noise	Bandwidth: $f = 0.1\text{ to }10\text{ Hz}$		8.1		$\mu\text{V}_{pp}$
THD+N	Total harmonic distortion + noise	$f = 1\text{ kHz}$ , $A_v = +1$ , $R_L = 10\text{ k}\Omega$ , $V_{out} = 2\text{ }V_{rms}$		0.002		%

1. Typical value is based on the  $V_{io}$  drift observed after 1000h at  $125\text{ }^{\circ}\text{C}$  extrapolated to  $25\text{ }^{\circ}\text{C}$  using the Arrhenius law and assuming an activation energy of 0.7 eV. The operational amplifier is aged in follower mode configuration. See [Section 4.6: Long-term input offset voltage drift](#).
2. When used in comparator mode, with high differential input voltage, during a long period of time with  $V_{CC}$  close to 16V and  $V_{icm} > V_{CC}/2$ ,  $V_{io}$  can experience a permanent drift of few mV drift. The phenomenon is particularly worsen at low temperatures.

**Table 5. Electrical characteristics at  $V_{CC+} = +10\text{ V}$  with  $V_{CC-} = 0\text{ V}$ ,  $V_{icm} = V_{CC}/2$ ,  $T_{amb} = 25\text{ }^\circ\text{C}$ , and  $R_L = 10\text{ k}\Omega$  connected to  $V_{CC}/2$  (unless otherwise specified)**

Symbol	Parameter	Conditions	Min.	Typ.	Max.	Unit
$V_{io}$	Input offset voltage	$T_{min} < T_{op} < T_{max}$			4 5	mV
$\Delta V_{io}/\Delta T$	Input offset voltage drift			2	10	$\mu\text{V}/^\circ\text{C}$
$\Delta V_{io}$	Long-term input offset voltage drift <sup>(1) (2)</sup>	TSX9291 TSX9292		92 128		$\frac{\text{nV}}{\sqrt{\text{month}}}$
$I_{ib}$	Input bias current	$V_{out} = V_{CC}/2$ $T_{min} < T_{op} < T_{max}$		10	100 200	pA
$I_{io}$	Input offset current	$V_{out} = V_{CC}/2$ $T_{min} < T_{op} < T_{max}$		10	100 200	
$R_{IN}$	Input resistance			1		$\text{T}\Omega$
$C_{IN}$	Input capacitance			8		pF
CMR	Common mode rejection ratio $20 \log (\Delta V_{ic}/\Delta V_{io})$	$V_{icm} = -0.1\text{ V to } 7\text{ V}$ , $V_{OUT} = V_{CC}/2$ $T_{min} < T_{op} < T_{max}$	72 70	85		dB
		$V_{icm} = -0.1\text{ V to } 10.1\text{ V}$ , $V_{OUT} = V_{CC}/2$ $T_{min} < T_{op} < T_{max}$	64 62	75		
$A_{vd}$	Large signal voltage gain	$R_L = 2\text{ k}\Omega$ , $V_{out} = 0.3\text{ V to } 9.7\text{ V}$ $T_{min} < T_{op} < T_{max}$	100 90	107		
		$R_L = 10\text{ k}\Omega$ , $V_{out} = 0.2\text{ V to } 9.8\text{ V}$ $T_{min} < T_{op} < T_{max}$	100 90	117		
$V_{OH}$	High level output voltage	$R_L = 2\text{ k}\Omega$ to $V_{CC}/2$ $T_{min} < T_{op} < T_{max}$  $R_L = 10\text{ k}\Omega$ to $V_{CC}/2$ $T_{min} < T_{op} < T_{max}$		94  31	110 130  40 50	mV from $V_{CC+}$
$V_{OL}$	Low level output voltage	$R_L = 2\text{ k}\Omega$ to $V_{CC}/2$ $T_{min} < T_{op} < T_{max}$		80	110 130	mV
		$R_L = 10\text{ k}\Omega$ to $V_{CC}/2$ $T_{min} < T_{op} < T_{max}$		14	40 50	
$I_{out}$	$I_{sink}$	$V_{out} = 10\text{ V}$ $T_{min} < T_{op} < T_{max}$	50 42	55		mA
	$I_{source}$	$V_{out} = 0\text{ V}$ $T_{min} < T_{op} < T_{max}$	75 70	82		
$I_{CC}$	Supply current (per amplifier)	No load, $V_{out} = V_{CC}/2$ $T_{min} < T_{op} < T_{max}$		3.1	3.6 3.6	
GBP	Gain bandwidth product	$R_L = 10\text{ k}\Omega$ , $C_L = 20\text{ pF}$ , $G = 20\text{ dB}$		16		MHz
$F_U$	Unity gain frequency	$R_L = 10\text{ k}\Omega$ , $C_L = 20\text{ pF}$		15.4		
Gain	Minimum gain for stability	Phase margin = $60^\circ$ , $R_g = R_f = 1\text{ k}\Omega$ $R_L = 10\text{ k}\Omega$ , $C_L = 20\text{ pF}$		-1 +2		

**Table 5. Electrical characteristics at  $V_{CC+} = +10\text{ V}$  with  $V_{CC-} = 0\text{ V}$ ,  $V_{icm} = V_{CC}/2$ ,  $T_{amb} = 25\text{ }^{\circ}\text{C}$ , and  $R_L = 10\text{ k}\Omega$  connected to  $V_{CC}/2$  (unless otherwise specified) (continued)**

Symbol	Parameter	Conditions	Min.	Typ.	Max.	Unit
SR+	Positive slew rate	$A_v = +1$ , $V_{out} = 0.5\text{ to }9.5\text{ V}$ Measured between 10 % to 90 %		29		V/ $\mu\text{s}$
SR-	Negative slew rate	$A_v = +1$ , $V_{out} = 9.5\text{ to }0.5\text{ V}$ Measured between 90 % to 10 %		30		
$e_n$	Equivalent input noise voltage	$f = 10\text{ kHz}$ $f = 100\text{ kHz}$		16.8 12		$\frac{\text{nV}}{\sqrt{\text{Hz}}}$
$\int e_n$	Low-frequency peak-to-peak input noise	Bandwidth: $f = 0.1\text{ to }10\text{ Hz}$		8.64		$\mu\text{V}_{pp}$
THD+N	Total harmonic distortion + noise	$f = 1\text{ kHz}$ , $A_v = +1$ , $R_L = 10\text{ k}\Omega$ , $V_{out} = 2\text{ V}_{rms}$		0.0006		%

1. Typical value is based on the  $V_{io}$  drift observed after 1000h at 125°C extrapolated to 25°C using the Arrhenius law and assuming an activation energy of 0.7 eV. The operational amplifier is aged in follower mode configuration. See [Section 4.6: Long-term input offset voltage drift](#).
2. When used in comparator mode, with high differential input voltage, during a long period of time with  $V_{CC}$  close to 16V and  $V_{icm} > V_{CC}/2$ ,  $V_{io}$  can experience a permanent drift of few mV drift. The phenomenon is particularly worsen at low temperatures.



**Table 6. Electrical characteristics at  $V_{CC+} = +16\text{ V}$  with  $V_{CC-} = 0\text{ V}$ ,  $V_{icm} = V_{CC}/2$ ,  $T_{amb} = 25\text{ }^{\circ}\text{C}$ , and  $R_L = 10\text{ k}\Omega$  connected to  $V_{CC}/2$  (unless otherwise specified)**

Symbol	Parameter	Conditions	Min.	Typ.	Max.	Unit
$V_{io}$	Input offset voltage	$T_{min} < T_{op} < T_{max}$			4 5	mV
$\Delta V_{io}/\Delta T$	Input offset voltage drift			2	10	$\mu\text{V}/^{\circ}\text{C}$
$\Delta V_{io}$	Long-term input offset voltage drift <sup>(1) (2)</sup>	TSX9291 TSX9292		1.73 2.26		$\frac{\mu\text{V}}{\sqrt{\text{month}}}$
$I_{ib}$	Input bias current	$V_{out} = V_{CC}/2$ $T_{min} < T_{op} < T_{max}$		10	100 200	pA
$I_{io}$	Input offset current	$V_{out} = V_{CC}/2$ $T_{min} < T_{op} < T_{max}$		10	100 200	
$R_{IN}$	Input resistance			1		T $\Omega$
$C_{IN}$	Input capacitance			8		pF
CMR	Common mode rejection ratio $20 \log (\Delta V_{ic}/\Delta V_{io})$	$V_{icm} = -0.1\text{ V to } 13\text{ V}$ , $V_{OUT} = V_{CC}/2$ $T_{min} < T_{op} < T_{max}$	73 71	85		dB
		$V_{icm} = -0.1\text{ V to } 16.1\text{ V}$ , $V_{OUT} = V_{CC}/2$ $T_{min} < T_{op} < T_{max}$	67 65	76		
SVR	Supply voltage rejection ratio	$V_{cc} = 4.5\text{ V to } 16\text{ V}$ $T_{min} < T_{op} < T_{max}$	73 71	85		
$A_{vd}$	Large signal voltage gain	$R_L = 2\text{ k}\Omega$ , $V_{out} = 0.3\text{ V to } 15.7\text{ V}$ $T_{min} < T_{op} < T_{max}$	100 90	105		
		$R_L = 10\text{ k}\Omega$ , $V_{out} = 0.2\text{ V to } 15.8\text{ V}$ $T_{min} < T_{op} < T_{max}$	100 90	113		
$V_{OH}$	High level output voltage	$R_L = 2\text{ k}\Omega$ to $V_{CC}/2$ $T_{min} < T_{op} < T_{max}$		150	200 230	mV from $V_{CC+}$
		$R_L = 10\text{ k}\Omega$ to $V_{CC}/2$ $T_{min} < T_{op} < T_{max}$		43	50 70	
$V_{OL}$	Low level output voltage	$R_L = 2\text{ k}\Omega$ to $V_{CC}/2$ $T_{min} < T_{op} < T_{max}$		140	200 230	mV
		$R_L = 10\text{ k}\Omega$ to $V_{CC}/2$ $T_{min} < T_{op} < T_{max}$		30	50 70	
$I_{out}$	$I_{sink}$	$V_{out} = 16\text{ V}$ $T_{min} < T_{op} < T_{max}$	45 40	50		mA
	$I_{source}$	$V_{out} = 0\text{ V}$ $T_{min} < T_{op} < T_{max}$	65 60	74		
$I_{CC}$	Supply current (per amplifier)	No load, $V_{out} = V_{CC}/2$ $T_{min} < T_{op} < T_{max}$		2.8	3.4 3.4	
GBP	Gain bandwidth product	$R_L = 10\text{ k}\Omega$ , $C_L = 20\text{ pF}$ , $G = 20\text{ dB}$		16		MHz
$F_U$	Unity gain frequency	$R_L = 10\text{ k}\Omega$ , $C_L = 20\text{ pF}$		15.7		

**Table 6. Electrical characteristics at  $V_{CC+} = +16\text{ V}$  with  $V_{CC-} = 0\text{ V}$ ,  $V_{icm} = V_{CC}/2$ ,  $T_{amb} = 25\text{ ° C}$ , and  $R_L = 10\text{ k}\Omega$  connected to  $V_{CC}/2$  (unless otherwise specified) (continued)**

Symbol	Parameter	Conditions	Min.	Typ.	Max.	Unit
Gain	Minimum gain for stability	Phase margin = 60 °, $R_g = R_f = 1\text{ k}\Omega$ $R_L = 10\text{ k}\Omega$ , $C_L = 20\text{ pF}$		-1 +2		
SR+	Positive slew rate	$A_v = +1$ , $V_{out} = 0.5\text{ to }15.5\text{ V}$ Measured between 10 % to 90 %		26		V/ $\mu$ s
SR-	Negative slew rate	$A_v = +1$ , $V_{out} = 15.5\text{ to }0.5\text{ V}$ Measured between 90 % to 10 %		27		
$e_n$	Equivalent input noise voltage	$f = 10\text{ kHz}$ $f = 100\text{ kHz}$		16.5 11.8		$\frac{nV}{\sqrt{Hz}}$
$\int e_n$	Low-frequency peak-to-peak input noise	Bandwidth: $f = 0.1\text{ to }10\text{ Hz}$		8.58		$\mu V_{pp}$
THD+N	Total harmonic distortion + Noise	$f = 1\text{ kHz}$ , $A_v = +1$ , $R_L = 10\text{ k}\Omega$ , $V_{out} = 4V_{rms}$		0.0003		%
$t_s$	Settling time	Gain = +1, 100 mV input voltage 0.1 % of final value 1 % of final value		245 178		ns

1. Typical value is based on the  $V_{io}$  drift observed after 1000h at 125°C extrapolated to 25°C using the Arrhenius law and assuming an activation energy of 0.7 eV. The operational amplifier is aged in follower mode configuration. See [Section 4.6: Long-term input offset voltage drift](#).
2. When used in comparator mode, with high differential input voltage, during a long period of time with  $V_{CC}$  close to 16V and  $V_{icm} > V_{CC}/2$ ,  $V_{io}$  can experience a permanent drift of few mV drift. The phenomenon is particularly worsen at low temperatures.

Figure 2. Supply current vs. supply voltage

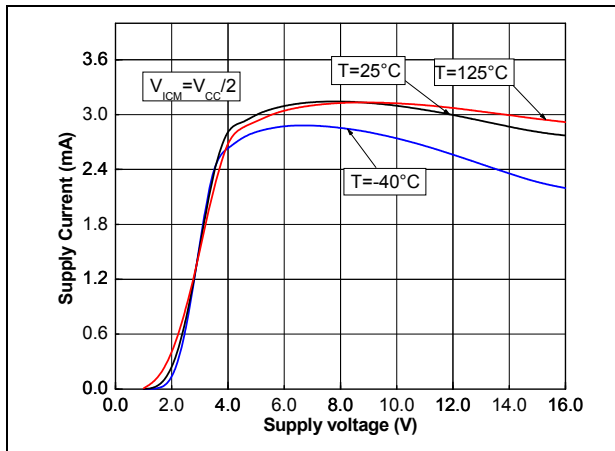

Figure 3. Distribution of input offset voltage at  $V_{CC} = 4.5\text{ V}$

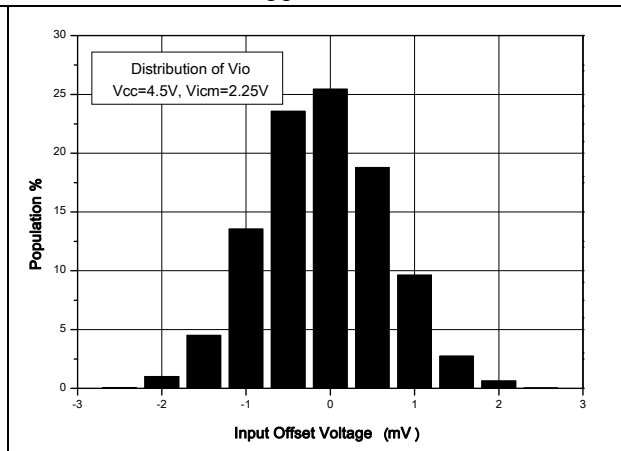

Figure 4. Distribution of input offset voltage at  $V_{CC} = 16\text{ V}$

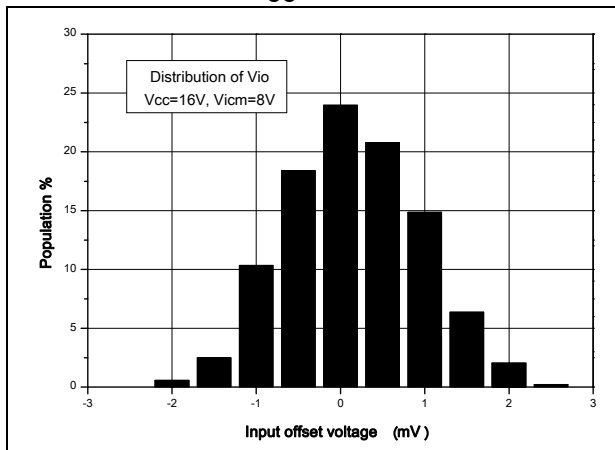

Figure 5. Input offset voltage vs. temperature at  $V_{CC} = 16\text{ V}$

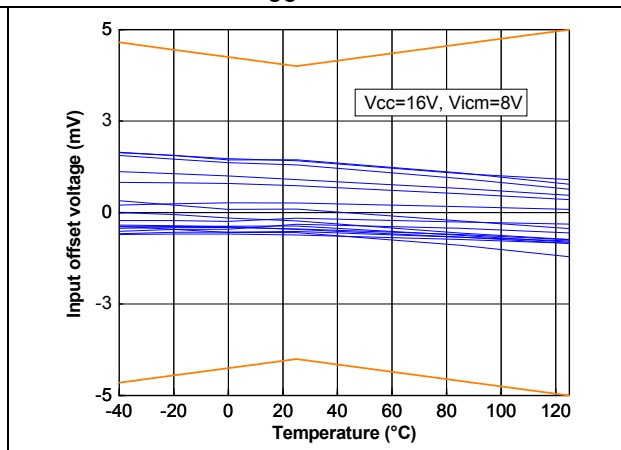

Figure 6. Distribution of input offset voltage drift over temperature

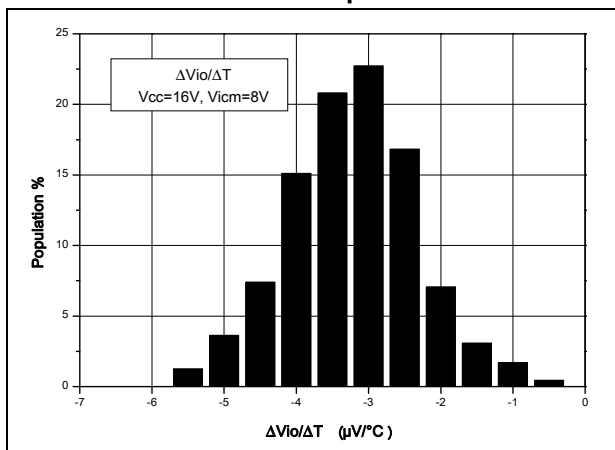

Figure 7. Input offset voltage vs. common mode voltage at  $V_{CC} = 4\text{ V}$

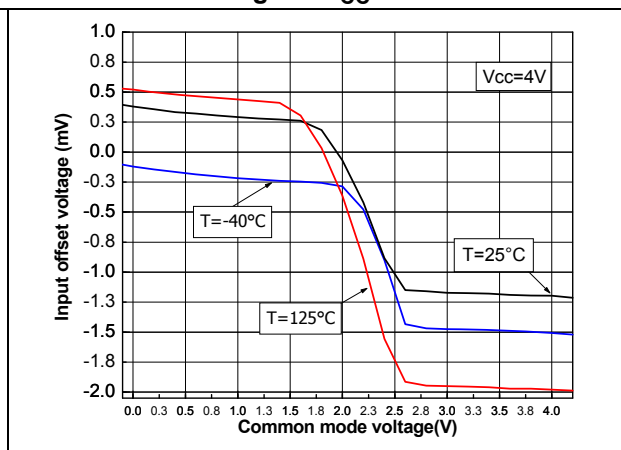

Figure 8. Input offset voltage vs. common mode voltage at  $V_{CC} = 16\text{ V}$

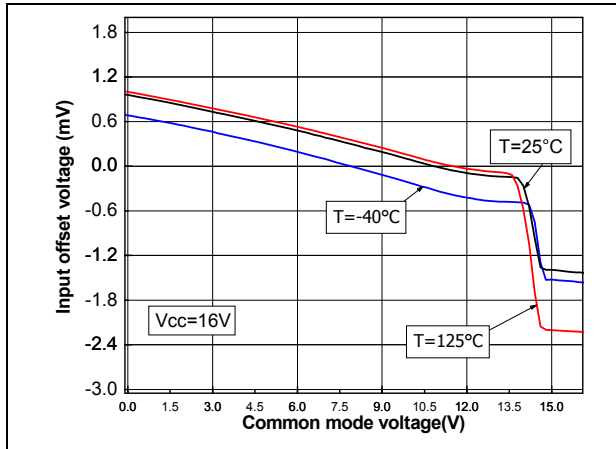

Figure 9. Output current vs. output voltage at  $V_{CC} = 4\text{ V}$

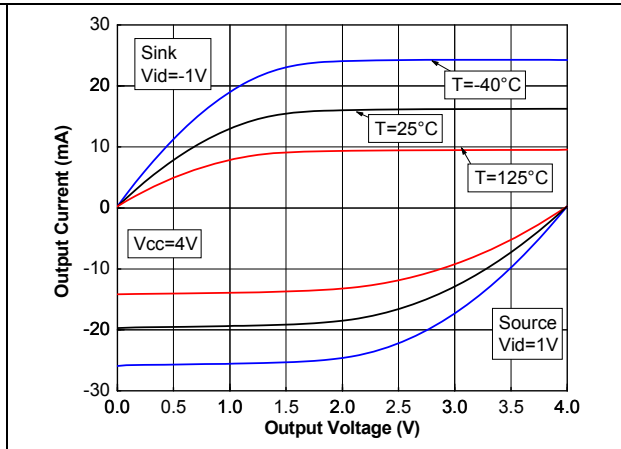

Figure 10. Output current vs. output voltage at  $V_{CC} = 10\text{ V}$

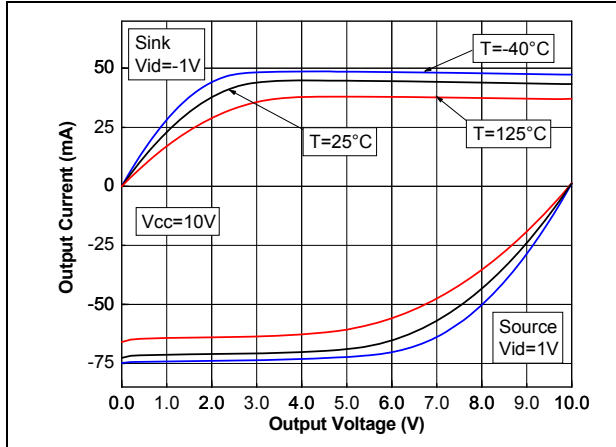

Figure 11. Output current vs. output voltage at  $V_{CC} = 16\text{ V}$

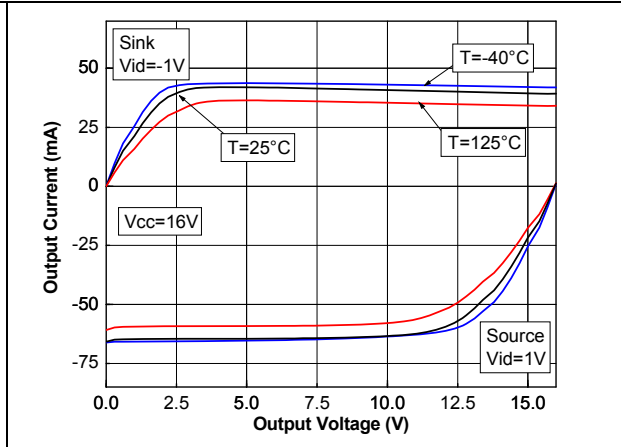

Figure 12. Output rail linearity

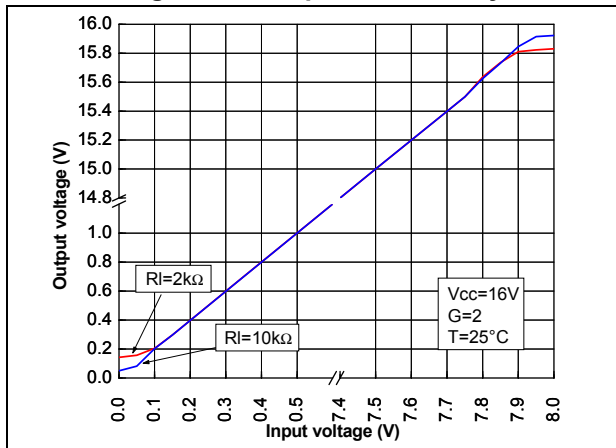

Figure 13. Open loop gain vs. frequency

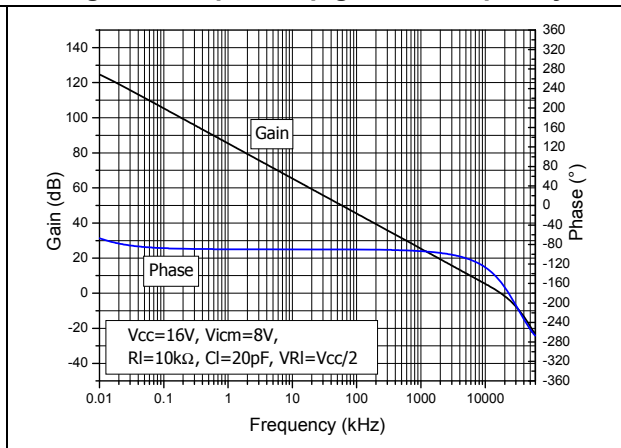

Figure 14. Bode diagram vs. temperature for  $V_{CC} = 4\text{ V}$

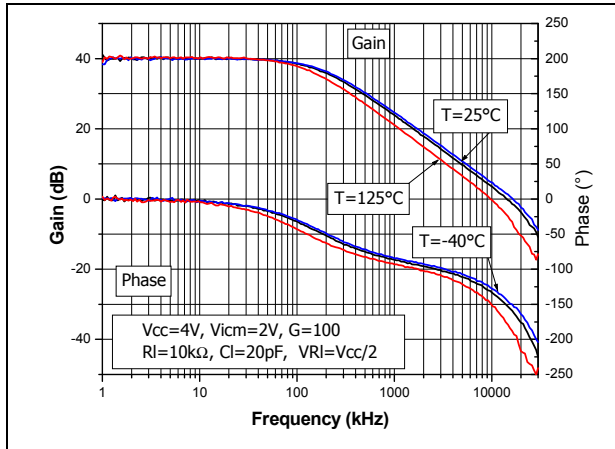

Figure 15. Bode diagram vs. temperature for  $V_{CC} = 10\text{ V}$

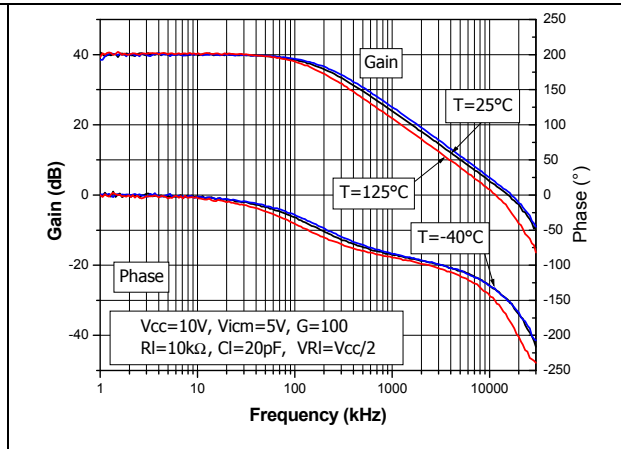

Figure 16. Bode diagram vs. temperature for  $V_{CC} = 16\text{ V}$

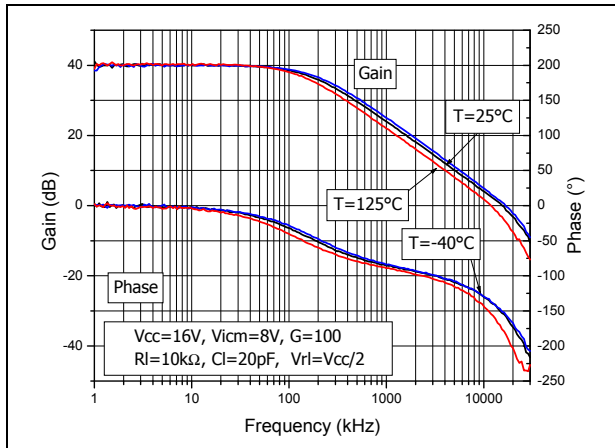

Figure 17. Bode diagram at  $V_{CC} = 16\text{ V}$  with low common mode voltage

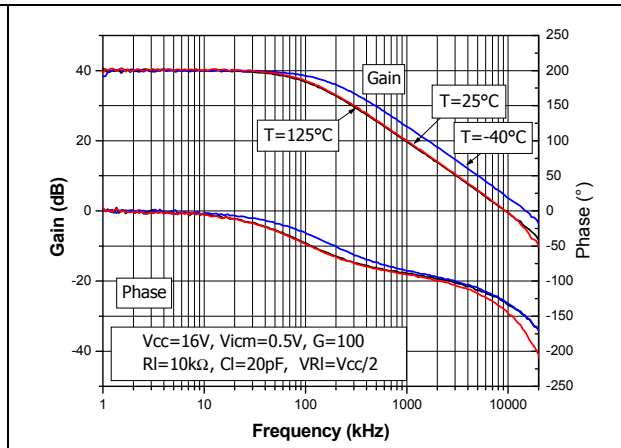

Figure 18. Bode diagram at  $V_{CC} = 16\text{ V}$  with high common mode voltage

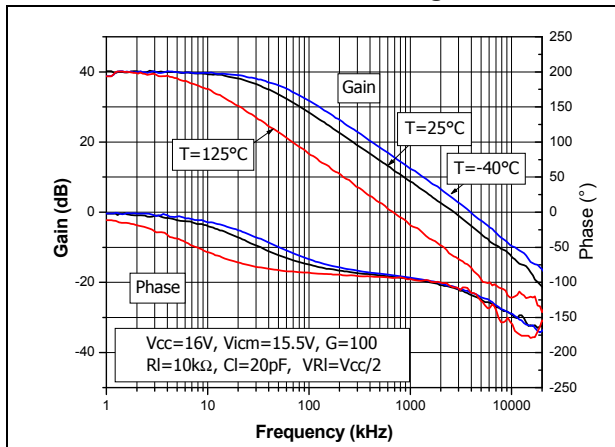

Figure 19. Bode diagram at  $V_{CC} = 16\text{ V}$  and  $R_L = 10\text{ k}\Omega$ ,  $C_L = 47\text{ pF}$

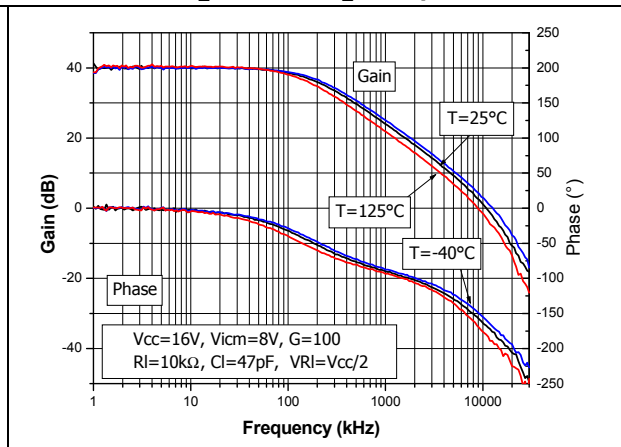

Figure 20. Bode diagram at  $V_{CC} = 16\text{ V}$  and  $R_L = 2\text{ k}\Omega$ ,  $C_L = 20\text{ pF}$

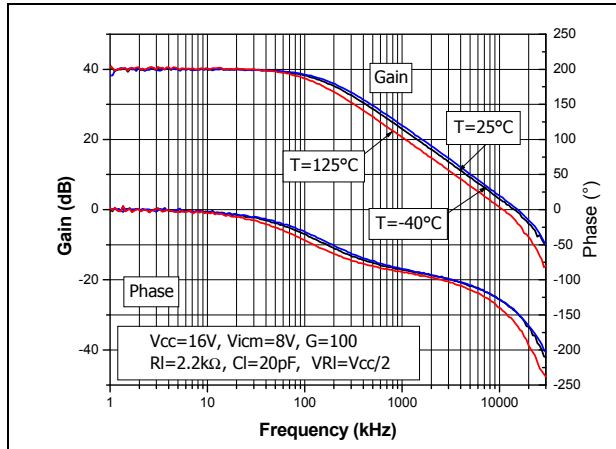

Figure 21. Slew rate vs. supply voltage and temperature

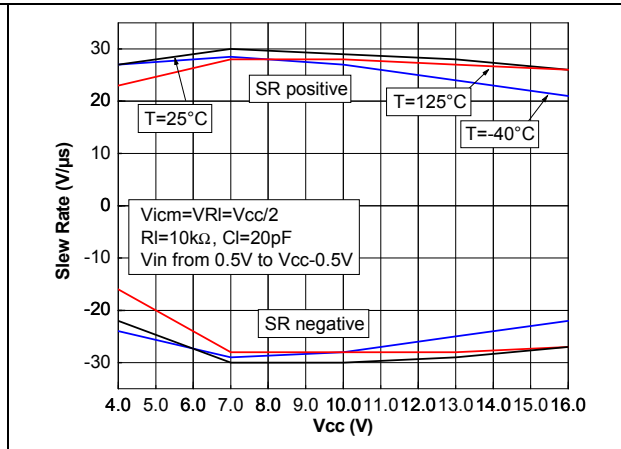

Figure 22. Small signal overshoot vs capacitive load without feedback capacitor  $C_f$

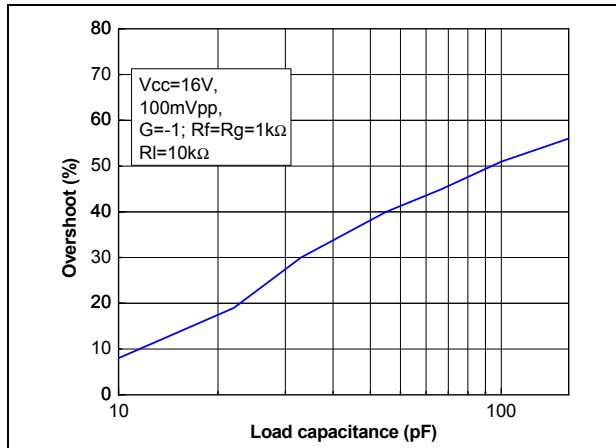

Figure 23. Small step response with  $G = +2$

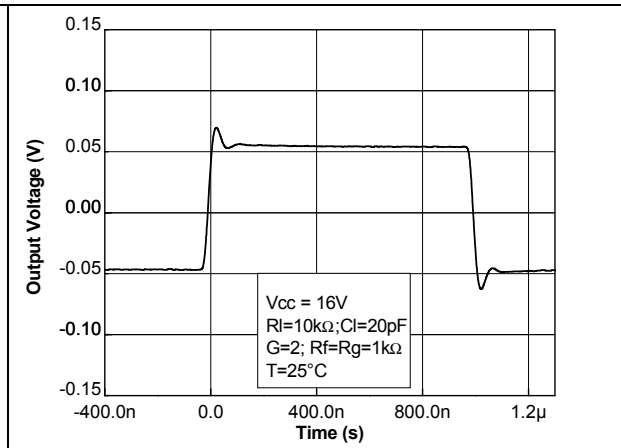

Figure 24. Small step response with feedback capacitor

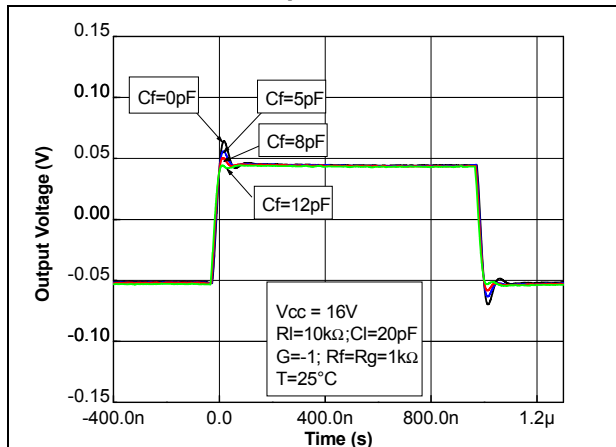

Figure 25. Large step response

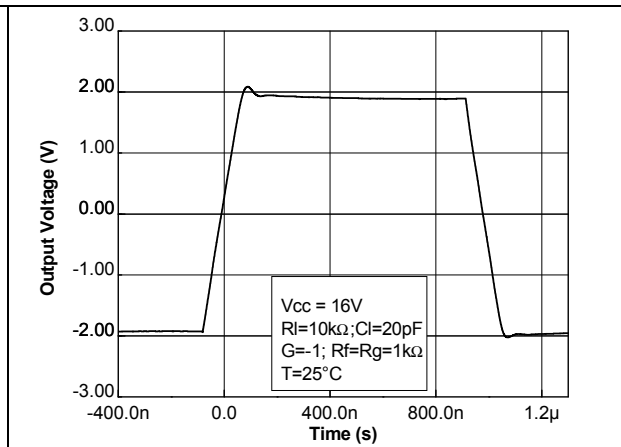

Figure 26. Desaturation time

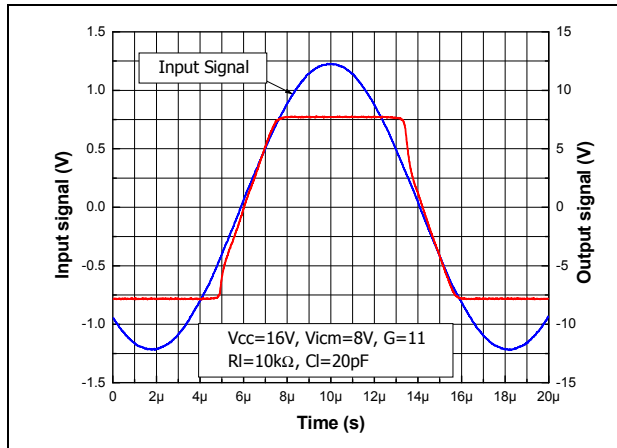

Figure 27. Peaking close loop with different  $R_i$

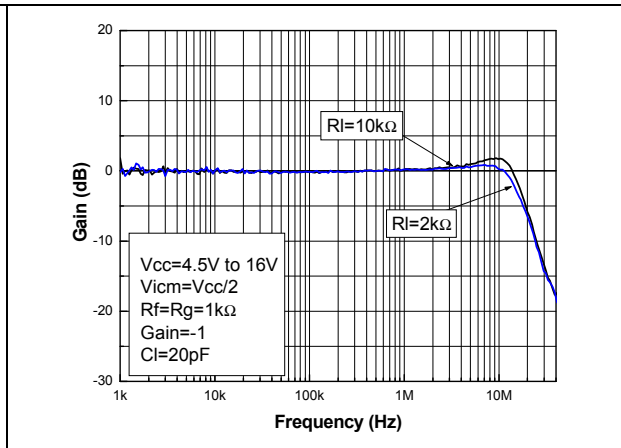

Figure 28. Output impedance vs frequency in close loop configuration

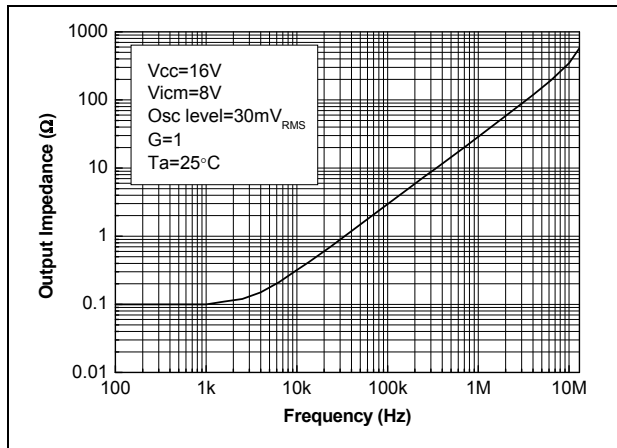

Figure 29. Noise vs. frequency with 16 V supply voltage

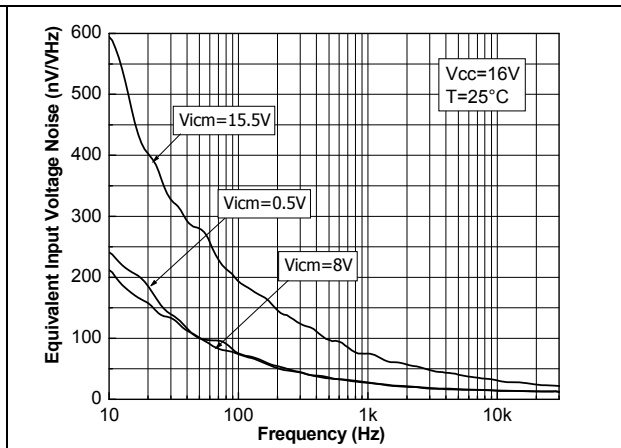

Figure 30. 0.1 to 10 Hz noise with 16 V supply voltage

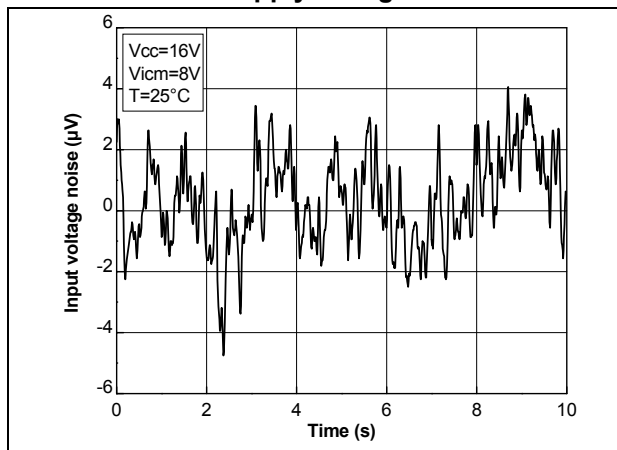

Figure 31. THD+N vs. frequency at  $V_{CC} = 16 V$

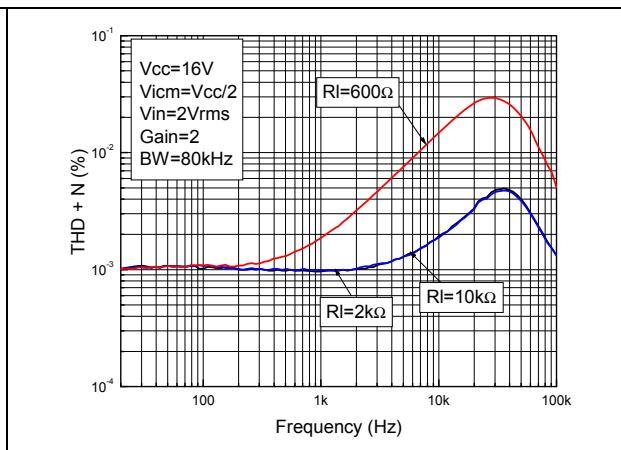

Figure 32. THD+N vs. output voltage at  $V_{CC} = 16\text{ V}$

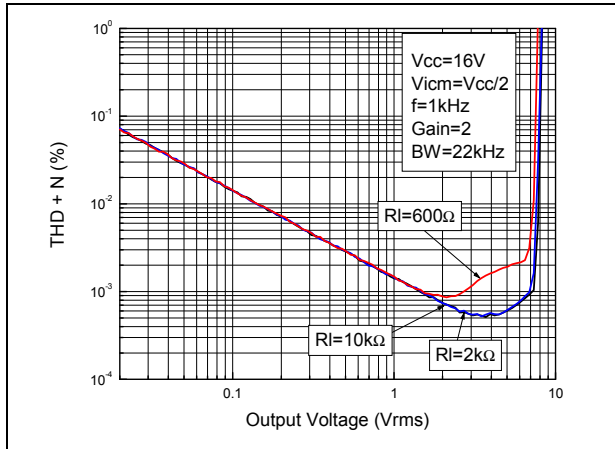

Figure 33. Power supply rejection ratio (PSRR) vs. frequency

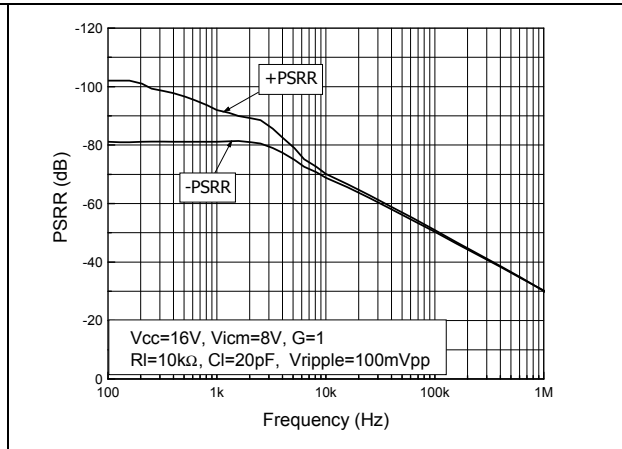
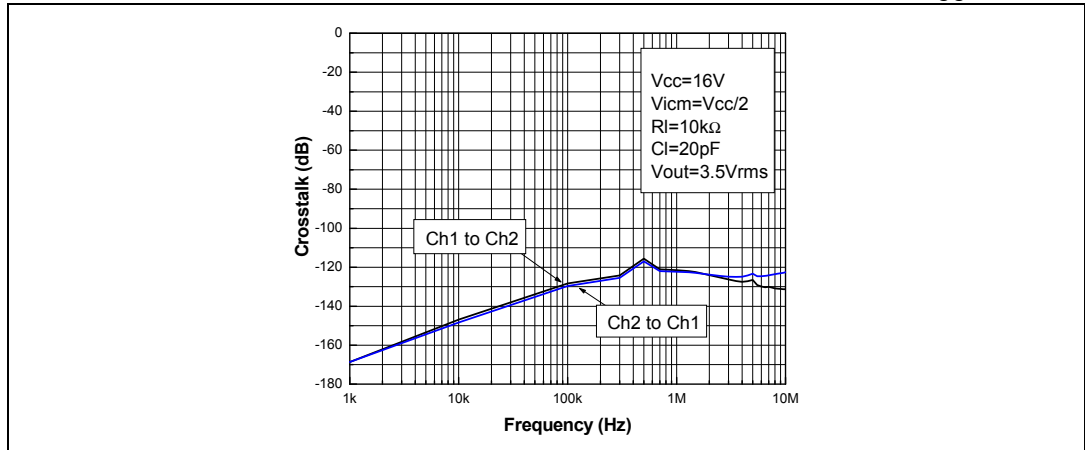

Figure 34. Crosstalk vs. frequency between operators on TSX9292 at  $V_{CC} = 16\text{ V}$





## 4 Application information

### 4.1 Operating voltages

The TSX929x series of operation amplifiers can operate from 4 V to 16 V. Parameters are fully specified at 4.5 V, 10 V, and 16 V power supplies. However, parameters are very stable in the full  $V_{CC}$  range. Additionally, the main specifications are guaranteed in the extended temperature range of -40 to +125 °C.

### 4.2 Rail-to-rail input

The TSX9291 and TSX9292 are designed with two complementary PMOS and NMOS input differential pairs. The devices have a rail-to-rail input and the input common mode range is extended from  $(V_{CC-}) - 0.1$  V to  $(V_{CC+}) + 0.1$  V. However, the performance of these devices is clearly optimized for the PMOS differential pairs (which means from  $(V_{CC-}) - 0.1$  V to  $(V_{CC+}) - 2$  V).

Beyond  $(V_{CC+}) - 2$  V, the operational amplifiers are still functional but with downgraded performances (see [Figure 19](#)). Performances are still suitable for a large number of applications requiring the rail-to-rail input feature.

TSX9291 and TSX9292 are designed to prevent phase reversal.

### 4.3 Input pin voltage range

The TSX929x series has internal ESD diode protection on the inputs. These diodes are connected between the input and each supply rail to protect MOSFETs inputs from electrostatic discharges.

Thus, if the input pin voltage exceeds the power supply by 0.5 V, the ESD diodes become conductive and excessive current could flow through them. To prevent any permanent damage, this current must be limited to 10 mA. This can be done by adding a resistor,  $R_s$ , in series with the input pin ([Figure 35](#)). The  $R_s$  resistor value has to be calculated for a 10 mA current limitation on the input pins.

**Figure 35. Limiting input current with a series resistor**

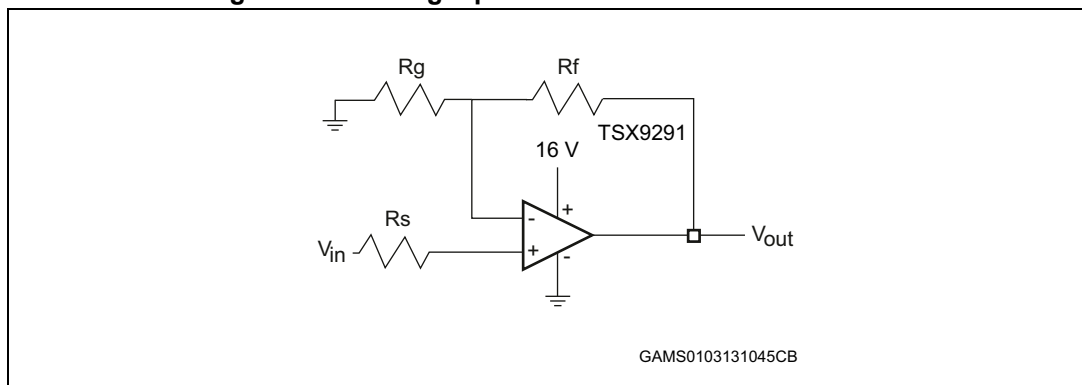

### 4.4 Stability for gain = -1

TSX9291 and TSX9292 can be used in gain = -1 configuration (see [Figure 36](#)). However some precautions must be taken regarding the setting of the Rg and Rf resistors. Effectively, the input capacitance of the TSX929x series creates a pole with Rf and Rg. In high frequency, this pole decreases the phase margin and also causes gain peaking. This effect has a direct impact on the stability.

[Figure 37](#) shows the peaking, depending on the values of the gain and feedback resistances.

**Figure 36. Configuration for gain = -1**

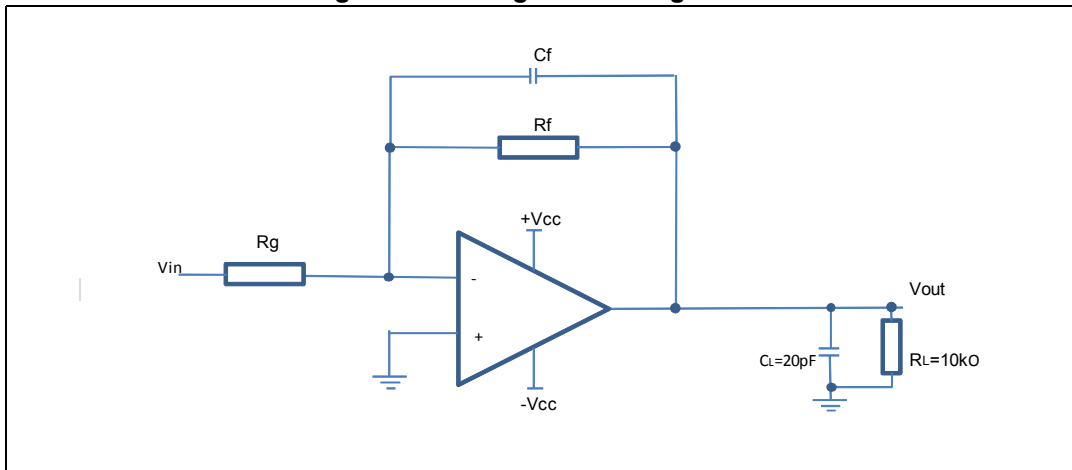

**Figure 37. Close loop gain vs. frequency**

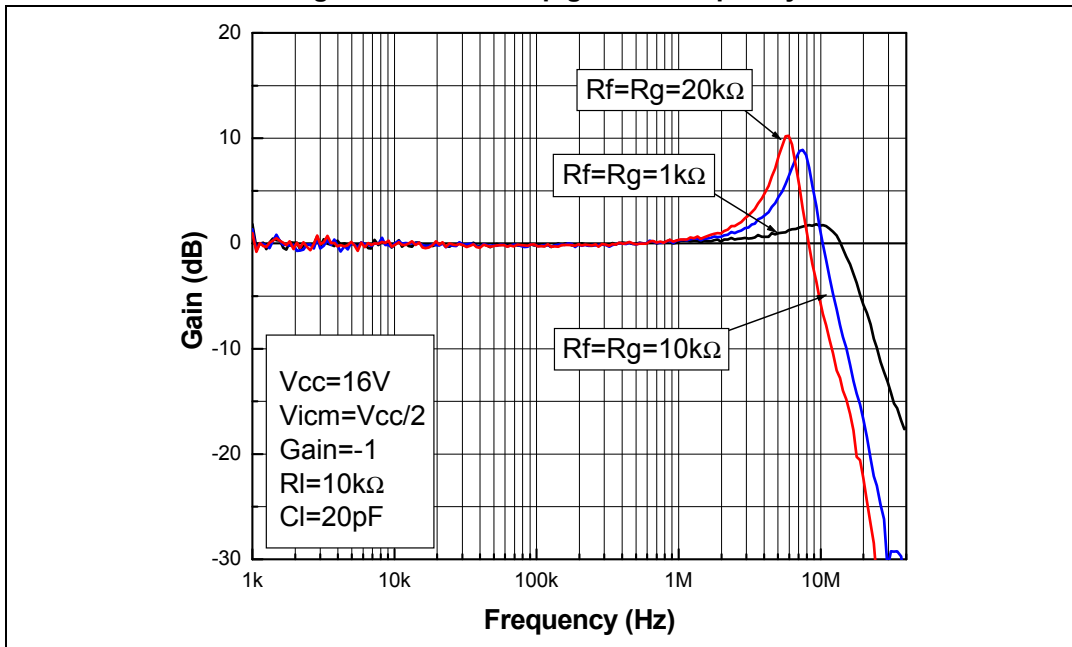

Whenever possible, it is best to choose smaller feedback resistors. It is recommended to use 1 kΩ gain and feedback resistance (Rf and Rg) when gain = -1 is necessary. In the application, if a large value of Rf and Rg has to be used, a feedback capacitance can be added in parallel with Rf, to reduce or eliminate the gain peaking. Additionally, Cf helps to compensate the input capacitance and to increase stability.

Figure 38 shows how Cf reduces the gain peaking.

**Figure 38. Close loop gain vs. frequency with capacitive compensation**

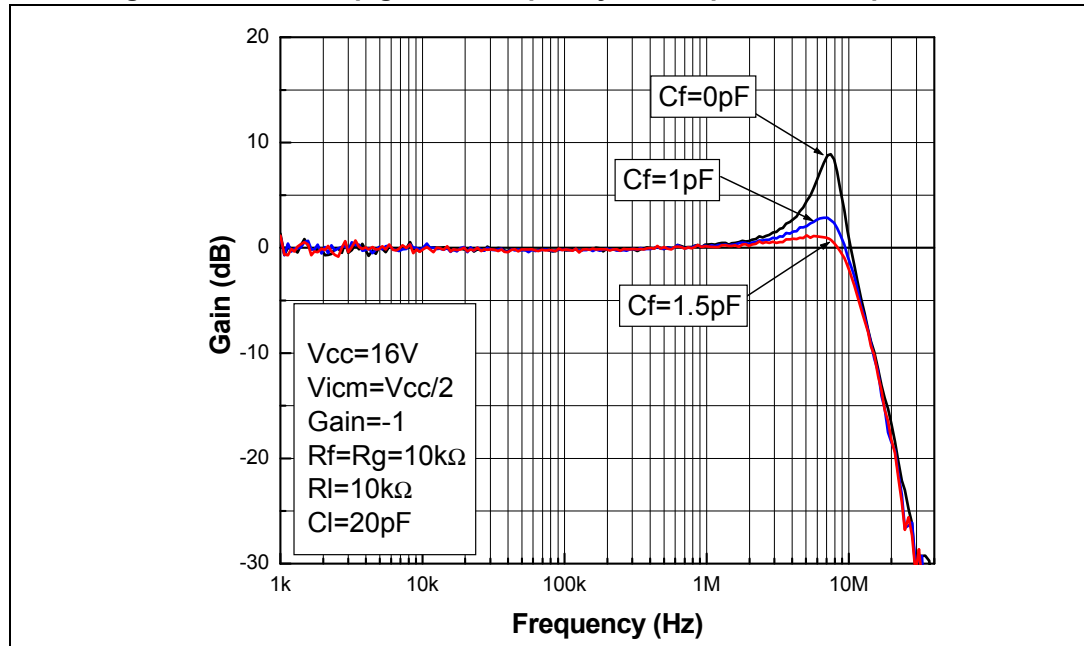

### 4.5 Input offset voltage drift over temperature

The maximum input voltage drift over the temperature variation is defined as the offset variation related to offset value measured at 25 °C. The operational amplifier is one of the main circuits of the signal conditioning chain, and the amplifier input offset is a major contributor to the chain accuracy. The signal chain accuracy at 25 °C can be compensated during production at application level. The maximum input voltage drift over temperature enables the system designer to anticipate the effect of temperature variations.

The maximum input voltage drift over temperature is computed using Equation 1.

**Equation 1**

$$\frac{\Delta V_{io}}{\Delta T} = \max \left| \frac{V_{io}(T) - V_{io}(25^\circ \text{C})}{T - 25^\circ \text{C}} \right|$$

with T = -40 °C and 125 °C.

The datasheet maximum value is guaranteed by a measurement on a representative sample size ensuring a C<sub>pk</sub> (process capability index) greater than 2.

## 4.6 Long-term input offset voltage drift

To evaluate product reliability, two types of stress acceleration are used:

- Voltage acceleration, by changing the applied voltage
- Temperature acceleration, by changing the die temperature (below the maximum junction temperature allowed by the technology) with the ambient temperature.

The voltage acceleration has been defined based on JEDEC results, and is defined using [Equation 2](#).

### Equation 2

$$A_{FV} = e^{\beta \cdot (V_S - V_U)}$$

Where:

$A_{FV}$  is the voltage acceleration factor

$\beta$  is the voltage acceleration constant in  $1/V$ , constant technology parameter ( $\beta = 1$ )

$V_S$  is the stress voltage used for the accelerated test

$V_U$  is the voltage used for the application

The temperature acceleration is driven by the Arrhenius model, and is defined in [Equation 3](#).

### Equation 3

$$A_{FT} = e^{\frac{E_a}{k} \cdot \left( \frac{1}{T_U} - \frac{1}{T_S} \right)}$$

Where:

$A_{FT}$  is the temperature acceleration factor

$E_a$  is the activation energy of the technology based on the failure rate

$k$  is the Boltzmann constant ( $8.6173 \times 10^{-5} \text{ eV.K}^{-1}$ )

$T_U$  is the temperature of the die when  $V_U$  is used (K)

$T_S$  is the temperature of the die under temperature stress (K)

The final acceleration factor,  $A_F$ , is the multiplication of the voltage acceleration factor and the temperature acceleration factor ([Equation 4](#)).

### Equation 4

$$A_F = A_{FT} \times A_{FV}$$

$A_F$  is calculated using the temperature and voltage defined in the mission profile of the product. The  $A_F$  value can then be used in [Equation 5](#) to calculate the number of months of use equivalent to 1000 hours of reliable stress duration.

**Equation 5**

$$\text{Months} = A_F \times 1000 \text{ h} \times 12 \text{ months} / (24 \text{ h} \times 365.25 \text{ days})$$

To evaluate the op-amp reliability, a follower stress condition is used where  $V_{CC}$  is defined as a function of the maximum operating voltage and the absolute maximum rating (as recommended by JEDEC rules).

The  $V_{io}$  drift (in  $\mu\text{V}$ ) of the product after 1000 h of stress is tracked with parameters at different measurement conditions (see [Equation 6](#)).

**Equation 6**

$$V_{CC} = \max V_{op} \text{ with } V_{icm} = V_{CC} / 2$$

The long-term drift parameter ( $\Delta V_{io}$ ), estimating the reliability performance of the product, is obtained using the ratio of the  $V_{io}$  (input offset voltage value) drift over the square root of the calculated number of months ([Equation 7](#)).

**Equation 7**

$$\Delta V_{io} = \frac{V_{io} \text{ drift}}{\sqrt{(\text{months})}}$$

where  $V_{io}$  drift is the measured drift value in the specified test conditions after 1000 h stress duration.

**4.7 Capacitive load**

Driving a large capacitive load can cause stability issues. Increasing the load capacitance produces gain peaking in the frequency response, with overshooting and ringing in the step response. It is usually considered that with a gain peaking higher than 2.3 dB the op-amp might become unstable. Generally, the unity gain configuration is the worst configuration for stability and the ability to drive large capacitive loads. [Figure 39](#) shows the serial resistor (Riso) that must be added to the output, to make the system stable. [Figure 40](#) shows the test configuration for Riso.

Figure 39. Stability criteria with a serial resistor

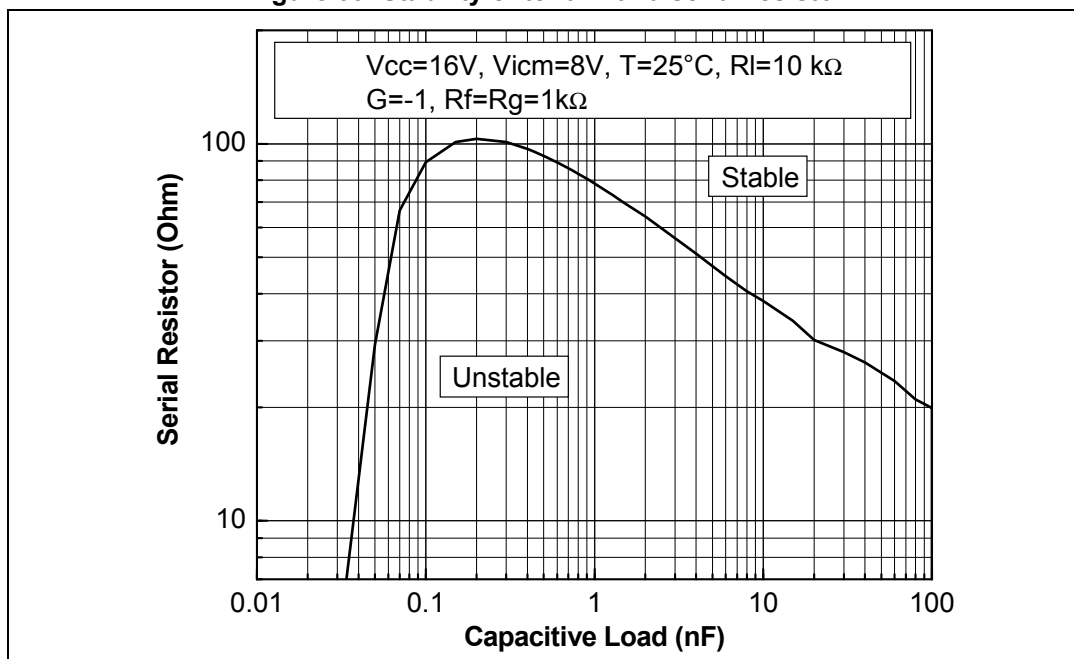
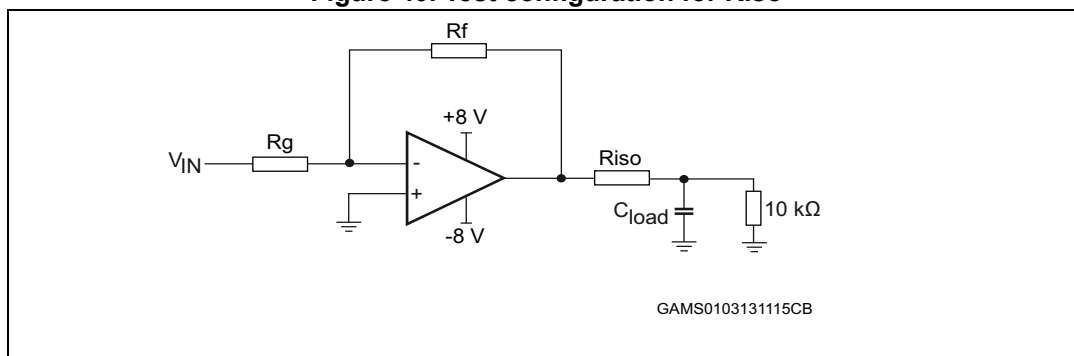

Figure 40. Test configuration for Riso



### 4.8 High side current sensing

TSX9291 and TSX9292 rail to rail input devices can be used to measure a small differential voltage on a high side shunt resistor and translate it into a ground referenced output voltage. The gain is fixed by external resistance.

**Figure 41. High side current sensing configuration**

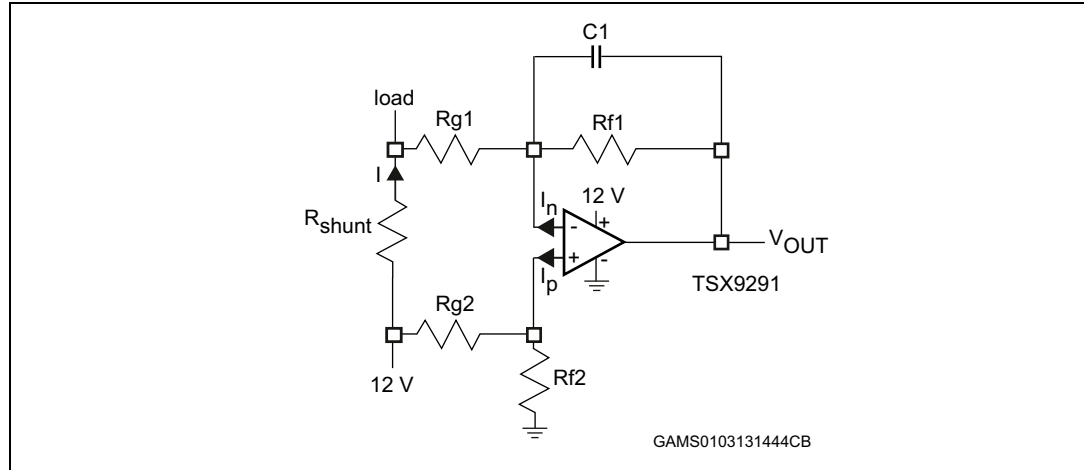

$V_{OUT}$  can be expressed as shown in [Equation 8](#).

**Equation 8**

$$V_{out} = R_{shunt} \times I \left( 1 - \frac{R_{g2}}{R_{g2} + R_{f2}} \right) \left( 1 + \frac{R_{f1}}{R_{g1}} \right) + I_p \left( \frac{R_{g2} R_{f2}}{R_{g2} + R_{f2}} \right) \times \left( 1 + \frac{R_{f1}}{R_{g1}} \right) - I_n \times R_{f1} - V_{io} \left( 1 + \frac{R_{f1}}{R_{g1}} \right)$$

Assuming that  $R_{f2} = R_{f1} = R_f$  and  $R_{g2} = R_{g1} = R_g$ , [Equation 8](#) can be simplified as [Equation 9](#).

**Equation 9**

$$V_{out} = R_{shunt} \times I \left( \frac{R_f}{R_g} \right) - V_{io} \left( 1 + \frac{R_f}{R_g} \right) + R_f \times I_{io}$$

With the TSX929x series, the high side current measurement must be made by respecting the common mode voltage of the amplifier:  $(V_{CC-}) - 0.1V$  to  $(V_{CC+}) + 0.1V$ . If the application requires a higher common voltage, please refer to the TSC high side current sensing family.

### 4.9 High speed photodiode

The TSX929x series is an excellent choice for current to voltage (I-V) conversions. Due to the CMOS technology, the input bias currents are extremely low. Moreover, the low noise and high unity-gain bandwidth of TSX9291 TSX9292 make them particularly suitable for high-speed photodiode preamplifier applications.

The photodiode is considered as a capacitive current source. The input capacitance,  $C_{IN}$ , includes the parasitic input common mode capacitance,  $C_{CM}$  (3pF), and the input differential mode capacitance,  $C_{DIFF}$  (8pF).  $C_{IN}$  acts in parallel with the intrinsic capacitance of the photodiode,  $C_D$ . At higher frequencies, the capacitors affect the circuit response. The output capacitance of a current sensor has a strong effect on the stability of the op-amp feedback loop.

$C_F$  stabilizes the gain and limits the transimpedance bandwidth. To ensure good stability and to obtain good noise performance,  $C_F$  can be set as shown in [Equation 10](#).

**Equation 10**

$$C_F > \sqrt{\frac{C_{IN} + C_D}{2 \cdot \pi \cdot R_F \cdot F_{GBP}}} - C_{SMR}$$

where,

- $C_{IN} = C_{CM} + C_{DIFF} = 11$  pF
- $C_{DIFF}$  is the differential input capacitance: 8 pF typical
- $C_{CM}$  is the Common mode input capacitance: 3 pF typical
- $C_D$  is the intrinsic capacitance of the photodiode
- $C_{SMR}$  is the parasitic capacitance of the surface mount  $R_F$  resistor: 0.2 pF typical
- $F_{GBP}$  is the gain bandwidth product: 10 MHz at 16 V

$R_F$  fixes the gain as shown in [Equation 11](#).

**Equation 11**

$$V_{OUT} = R_F \times I_D$$

**Figure 42. High speed photodiode**

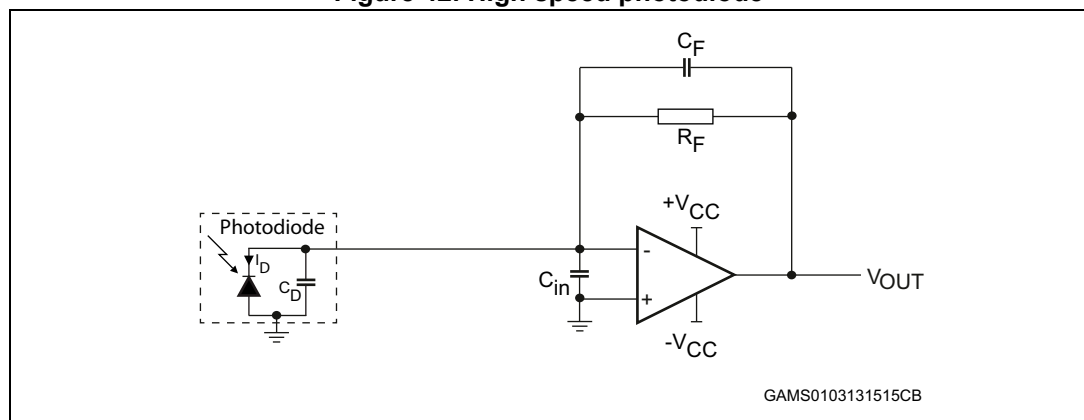



## 5 Package information

In order to meet environmental requirements, ST offers these devices in different grades of ECOPACK<sup>®</sup> packages, depending on their level of environmental compliance. ECOPACK<sup>®</sup> specifications, grade definitions and product status are available at: [www.st.com](http://www.st.com). ECOPACK<sup>®</sup> is an ST trademark.

### 5.1 SOT23-5 package mechanical data

Figure 43. SOT23-5 package mechanical drawing

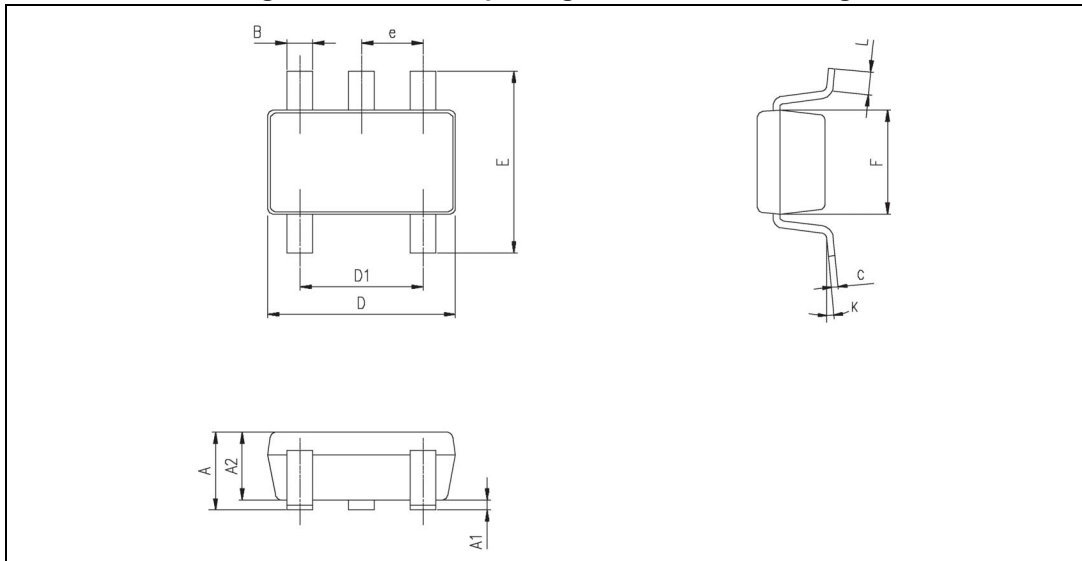

Table 7. SOT23-5 package mechanical data

Ref.	Dimensions					
	Millimeters			Inches		
	Min.	Typ.	Max.	Min.	Typ.	Max.
A	0.90	1.20	1.45	0.035	0.047	0.057
A1			0.15			0.006
A2	0.90	1.05	1.30	0.035	0.041	0.051
B	0.35	0.40	0.50	0.013	0.015	0.019
C	0.09	0.15	0.20	0.003	0.006	0.008
D	2.80	2.90	3.00	0.110	0.114	0.118
D1		1.90			0.075	
e		0.95			0.037	
E	2.60	2.80	3.00	0.102	0.110	0.118
F	1.50	1.60	1.75	0.059	0.063	0.069
L	0.10	0.35	0.60	0.004	0.013	0.023
K	0 °		10 °	0 °		10 °

## 5.2 DFN8 2x2 package information

Figure 44. DFN8 2x2 package mechanical drawing

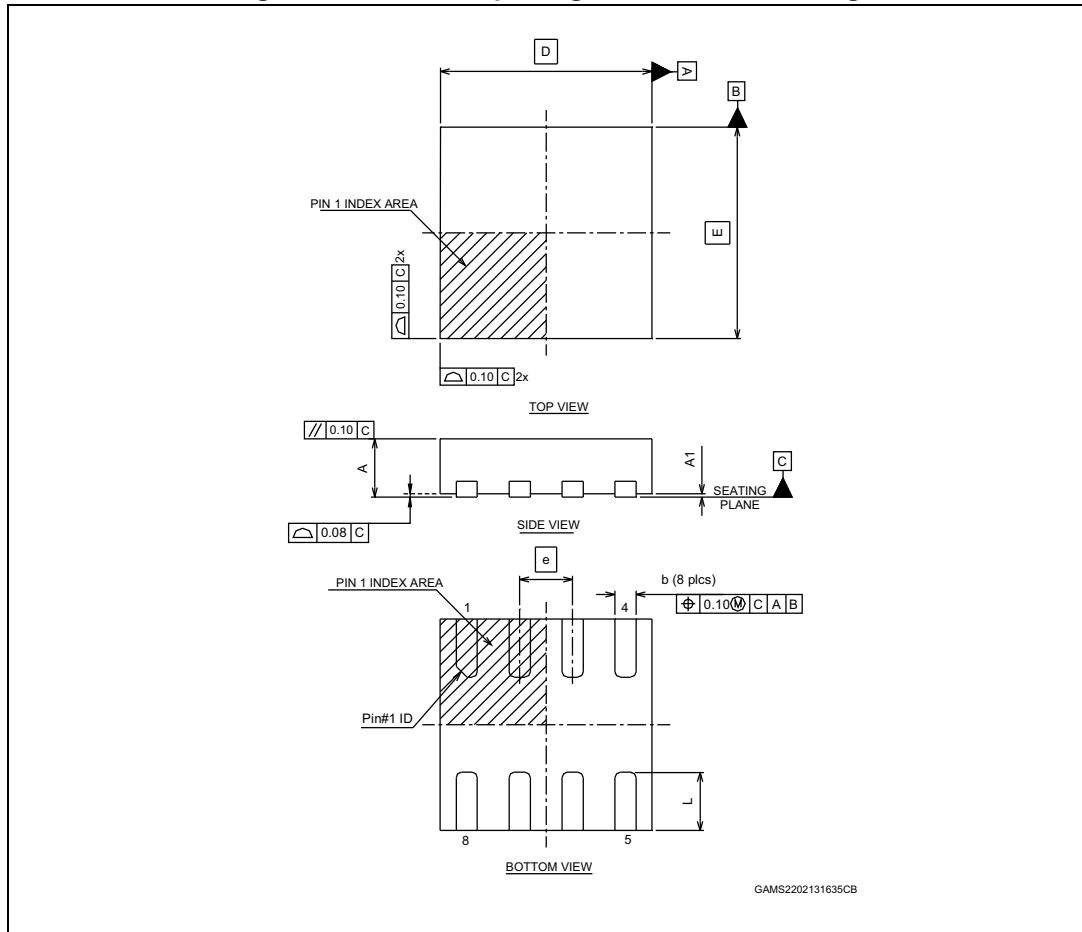

Table 8. DFN8 2x2 package mechanical data

Ref.	Dimensions					
	Millimeters			Inches		
	Min.	Typ.	Max.	Min.	Typ.	Max.
A	0.70	0.75	0.80	0.028	0.030	0.031
A1	0.00	0.02	0.05	0.000	0.001	0.002
b	0.15	0.20	0.25	0.006	0.008	0.010
D		2.00			0.079	
E		2.00			0.079	
e		0.50			0.020	
L	0.045	0.55	0.65	0.018	0.022	0.026
N	8					

### 5.3 MiniSO8 package information

Figure 45. MiniSO8 package mechanical drawing

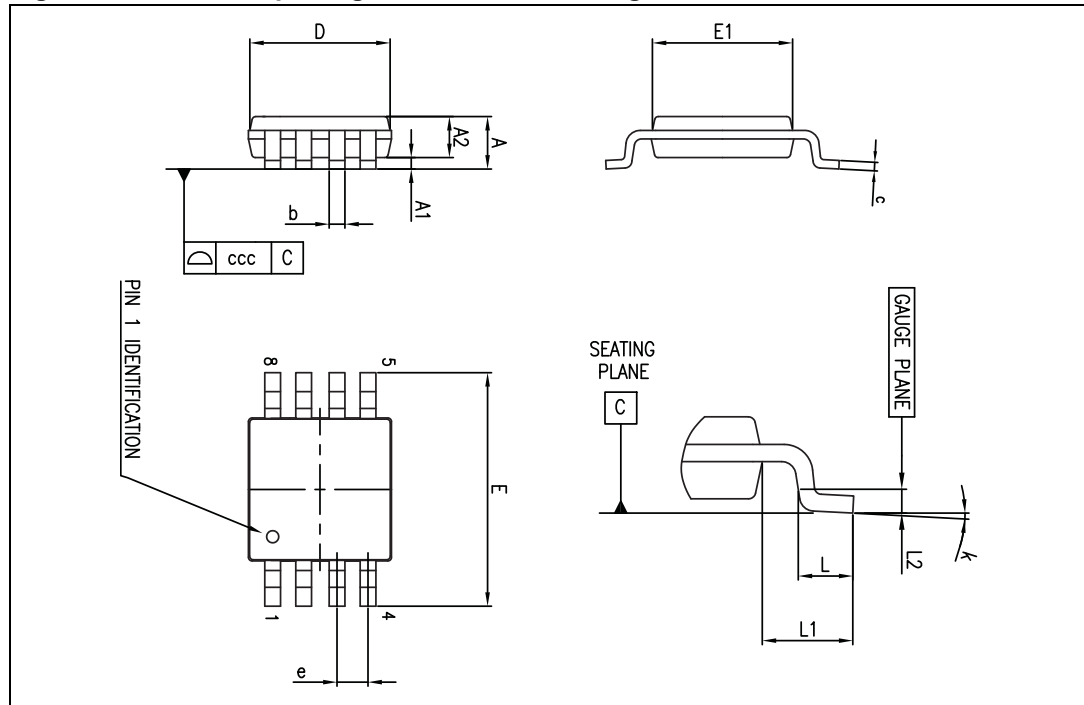

Table 9. MiniSO8 package mechanical data

Ref.	Dimensions					
	Millimeters			Inches		
	Min.	Typ.	Max.	Min.	Typ.	Max.
A			1.1			0.043
A1	0		0.15	0		0.006
A2	0.75	0.85	0.95	0.030	0.033	0.037
b	0.22		0.40	0.009		0.016
c	0.08		0.23	0.003		0.009
D	2.80	3.00	3.20	0.11	0.118	0.126
E	4.65	4.90	5.15	0.183	0.193	0.203
E1	2.80	3.00	3.10	0.11	0.118	0.122
e		0.65			0.026	
L	0.40	0.60	0.80	0.016	0.024	0.031
L1		0.95			0.037	
L2		0.25			0.010	
k	0°		8°	0°		8°
ccc			0.10			0.004

### 5.4 SO8 package information

Figure 46. SO8 package mechanical drawing

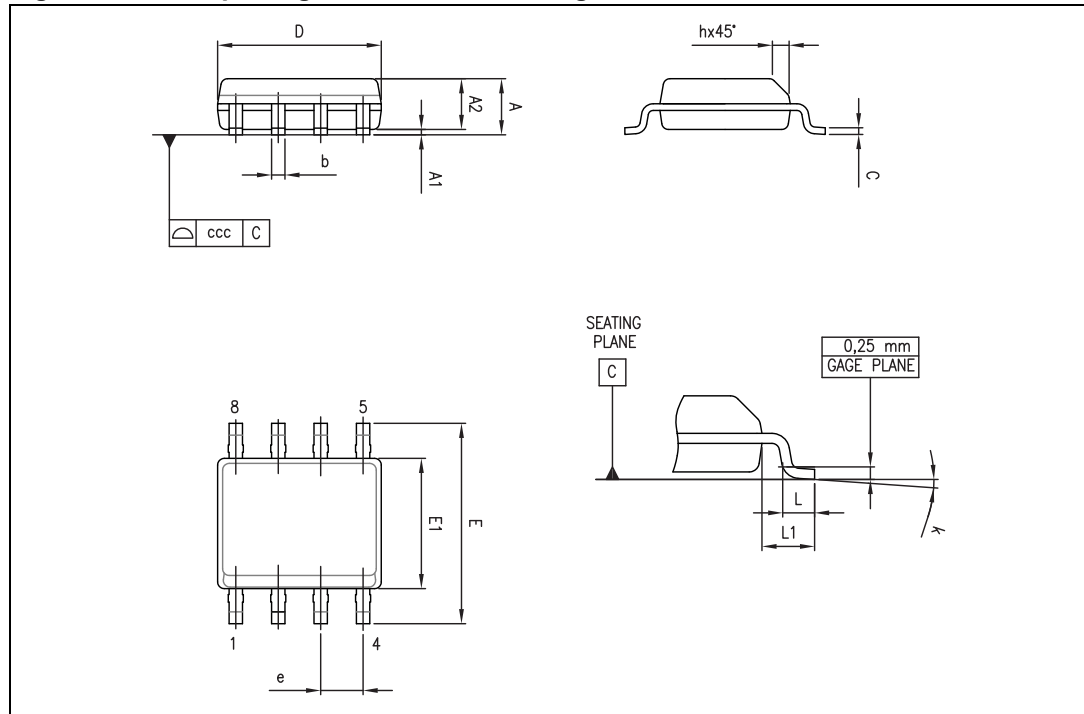

Table 10. SO8 package mechanical data

Ref.	Dimensions					
	Millimeters			Inches		
	Min.	Typ.	Max.	Min.	Typ.	Max.
A			1.75			0.069
A1	0.10		0.25	0.004		0.010
A2	1.25			0.049		
b	0.28		0.48	0.011		0.019
c	0.17		0.23	0.007		0.010
D	4.80	4.90	5.00	0.189	0.193	0.197
E	5.80	6.00	6.20	0.228	0.236	0.244
E1	3.80	3.90	4.00	0.150	0.154	0.157
e		1.27			0.050	
h	0.25		0.50	0.010		0.020
L	0.40		1.27	0.016		0.050
L1		1.04			0.040	
k	0°		8°	1°		8°
ccc			0.10			0.004

## 6 Ordering information

Table 11. Order codes

Order code	Temperature range	Package	Packing	Marking
TSX9291ILT	-40° C to +125° C	SOT23-5	Tape and reel	K28
TSX9291IYLT <sup>(1)</sup>				K209
TSX9292IQ2T		DFN8 2x2		K28
TSX9292IST		MiniSO8		
TSX9292IDT		SO8		TSX9292I
TSX9292IYDT <sup>(1)</sup>				SX9292IY

1. Qualified and characterized according to AEC Q100 and Q003 or equivalent, advanced screening according to AEC Q001 & Q 002 or equivalent.

## 7 Revision history

Table 12. Document revision history

Date	Revision	Changes
24-Apr-2013	1	Initial release
01-Jul-2013	2	Added the dual version op-amp (TSX9292) and updated the datasheet accordingly. Added the silhouettes, pin connections, and package information for DFN8 2x2, MiniSO8, and SO8; updated <a href="#">Table 2</a> . Added <a href="#">Figure 34</a> .
10-Dec-2013	3	Added long-term input offset voltage drift parameter in <a href="#">Table 4</a> , <a href="#">Table 5</a> , and <a href="#">Table 6</a> . Added <a href="#">Section 4.5: Input offset voltage drift over temperature</a> in <a href="#">Section 4: Application information</a> . Added <a href="#">Section 4.6: Long-term input offset voltage drift</a> in <a href="#">Section 4: Application information</a> . Corrected <a href="#">Figure 15: Bode diagram vs. temperature for VCC = 10 V</a> .
28-Apr-2014	4	<a href="#">Table 4</a> , <a href="#">Table 5</a> , and <a href="#">Table 6</a> : updated phase margin condition for the gain parameter. <a href="#">Section 4.3: Input pin voltage range</a> : added information concerning an Rs resistor; updated <a href="#">Figure 35</a> . <a href="#">Table 11</a> : updated markings of order codes TSX9291IYLT and TSX9291IQ2T.

**Please Read Carefully:**

Information in this document is provided solely in connection with ST products. STMicroelectronics NV and its subsidiaries ("ST") reserve the right to make changes, corrections, modifications or improvements, to this document, and the products and services described herein at any time, without notice.

All ST products are sold pursuant to ST's terms and conditions of sale.

Purchasers are solely responsible for the choice, selection and use of the ST products and services described herein, and ST assumes no liability whatsoever relating to the choice, selection or use of the ST products and services described herein.

No license, express or implied, by estoppel or otherwise, to any intellectual property rights is granted under this document. If any part of this document refers to any third party products or services it shall not be deemed a license grant by ST for the use of such third party products or services, or any intellectual property contained therein or considered as a warranty covering the use in any manner whatsoever of such third party products or services or any intellectual property contained therein.

**UNLESS OTHERWISE SET FORTH IN ST'S TERMS AND CONDITIONS OF SALE ST DISCLAIMS ANY EXPRESS OR IMPLIED WARRANTY WITH RESPECT TO THE USE AND/OR SALE OF ST PRODUCTS INCLUDING WITHOUT LIMITATION IMPLIED WARRANTIES OF MERCHANTABILITY, FITNESS FOR A PARTICULAR PURPOSE (AND THEIR EQUIVALENTS UNDER THE LAWS OF ANY JURISDICTION), OR INFRINGEMENT OF ANY PATENT, COPYRIGHT OR OTHER INTELLECTUAL PROPERTY RIGHT.**

**ST PRODUCTS ARE NOT DESIGNED OR AUTHORIZED FOR USE IN: (A) SAFETY CRITICAL APPLICATIONS SUCH AS LIFE SUPPORTING, ACTIVE IMPLANTED DEVICES OR SYSTEMS WITH PRODUCT FUNCTIONAL SAFETY REQUIREMENTS; (B) AERONAUTIC APPLICATIONS; (C) AUTOMOTIVE APPLICATIONS OR ENVIRONMENTS, AND/OR (D) AEROSPACE APPLICATIONS OR ENVIRONMENTS. WHERE ST PRODUCTS ARE NOT DESIGNED FOR SUCH USE, THE PURCHASER SHALL USE PRODUCTS AT PURCHASER'S SOLE RISK, EVEN IF ST HAS BEEN INFORMED IN WRITING OF SUCH USAGE, UNLESS A PRODUCT IS EXPRESSLY DESIGNATED BY ST AS BEING INTENDED FOR "AUTOMOTIVE, AUTOMOTIVE SAFETY OR MEDICAL" INDUSTRY DOMAINS ACCORDING TO ST PRODUCT DESIGN SPECIFICATIONS. PRODUCTS FORMALLY ESCC, QML OR JAN QUALIFIED ARE DEEMED SUITABLE FOR USE IN AEROSPACE BY THE CORRESPONDING GOVERNMENTAL AGENCY.**

Resale of ST products with provisions different from the statements and/or technical features set forth in this document shall immediately void any warranty granted by ST for the ST product or service described herein and shall not create or extend in any manner whatsoever, any liability of ST.

ST and the ST logo are trademarks or registered trademarks of ST in various countries.

Information in this document supersedes and replaces all information previously supplied.

The ST logo is a registered trademark of STMicroelectronics. All other names are the property of their respective owners.

© 2014 STMicroelectronics - All rights reserved

STMicroelectronics group of companies

Australia - Belgium - Brazil - Canada - China - Czech Republic - Finland - France - Germany - Hong Kong - India - Israel - Italy - Japan - Malaysia - Malta - Morocco - Philippines - Singapore - Spain - Sweden - Switzerland - United Kingdom - United States of America

[www.st.com](http://www.st.com)



## X-ON Electronics

Largest Supplier of Electrical and Electronic Components

*Click to view similar products for [Operational Amplifiers - Op Amps](#) category:*

*Click to view products by [STMicroelectronics](#) manufacturer:*

Other Similar products are found below :

[NCV33072ADR2G](#) [LM358SNG](#) [430227FB](#) [UPC824G2-A](#) [LT1678IS8](#) [042225DB](#) [058184EB](#) [UPC822G2-A](#) [UPC259G2-A](#) [UPC258G2-A](#)  
[NCV33202DMR2G](#) [NTE925](#) [AZV358MTR-G1](#) [AP4310AUMTR-AG1](#) [HA1630D02MMEL-E](#) [HA1630S01LPEL-E](#) [SCY33178DR2G](#)  
[NJU77806F3-TE1](#) [NCV5652MUTWG](#) [NCV20034DR2G](#) [LM324EDR2G](#) [LM2902EDR2G](#) [NTE7155](#) [NTE778S](#) [NTE871](#) [NTE924](#) [NTE937](#)  
[MCP6V17T-E/MNY](#) [MCP6V19-E/ST](#) [MXD8011HF](#) [MCP6V17T-E/MS](#) [SCY6358ADR2G](#) [ADA4523-1BCPZ](#) [LTC2065HUD#PBF](#)  
[ADA4523-1BCPZ-RL7](#) [2SD965T-R](#) [RS6332PXK](#) [BDM8551](#) [BDM321](#) [MD1324](#) [COS8052SR](#) [COS8552SR](#) [COS8554SR](#) [COS2177SR](#)  
[COS2353SR](#) [COS724TR](#) [ASOPD4580S-R](#) [RS321BKXF](#) [ADA4097-1HUIJZ-RL7](#) [NCS20282FCTTAG](#)