

## High voltage converter

Datasheet - production data



### Applications

- Auxiliary SMPS for:
  - home appliances
  - consumer goods
  - industrial
  - lighting

### Description

The device is a high performance high voltage converter that combines a 730 V rugged power MOSFET with PWM control. The device embeds high voltage startup and current sense circuitry, which helps reduce the number of components in a BoM. Frequency jittering spreads the EMI and allows the use of a smaller filter. The burst mode feature provides very low input power consumption at light loads.

### Features

- 730 V avalanche rugged power MOSFET
- PWM controller
- 3.3 V reference voltage
- Frequency jittering
- 40 mW no load input power at 230 V<sub>AC</sub>
- Short-circuit protection
- Thermal shutdown

Figure 1. VIPER122 block diagram

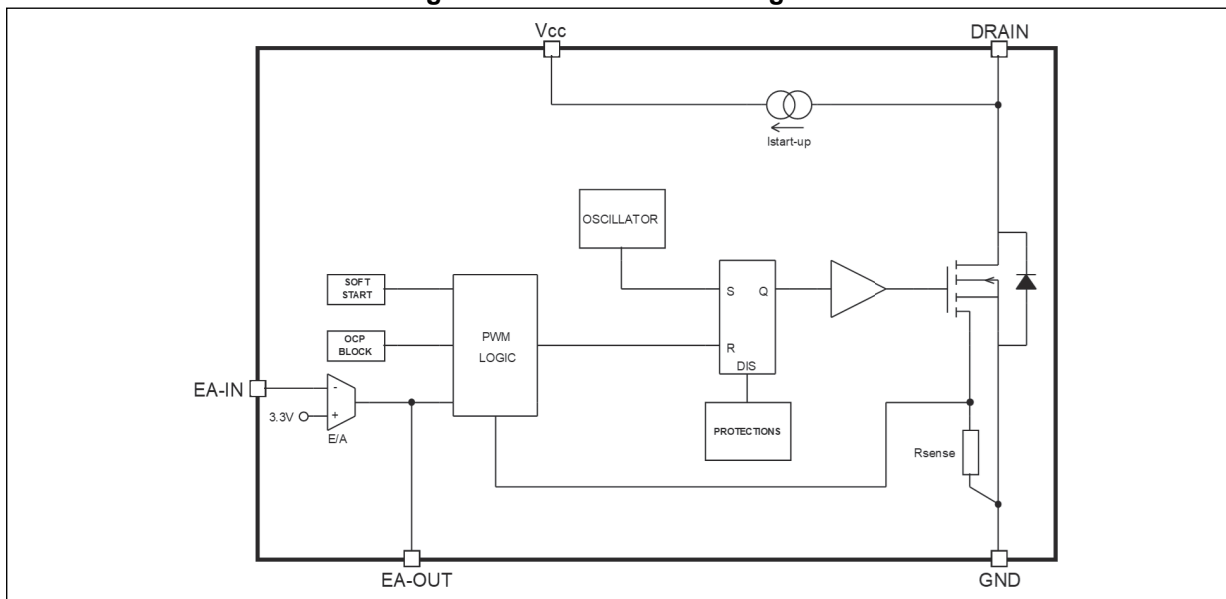

# Contents

<b>1</b>	<b>Pin settings</b> .....	<b>5</b>
<b>2</b>	<b>Typical power capability</b> .....	<b>6</b>
<b>3</b>	<b>Electrical and thermal ratings</b> .....	<b>7</b>
<b>4</b>	<b>Electrical characteristics</b> .....	<b>9</b>
<b>5</b>	<b>Typical electrical characteristics</b> .....	<b>11</b>
<b>6</b>	<b>General description</b> .....	<b>12</b>
6.1	Startup .....	12
6.2	Feedback loop .....	12
6.2.1	Resistor divider .....	12
6.2.2	Optocoupler .....	13
6.3	Burst mode at light load .....	13
6.4	Short-circuit protection .....	13
6.5	VCC clamp protection .....	13
<b>7</b>	<b>Basic application schematics</b> .....	<b>14</b>
<b>8</b>	<b>Package information</b> .....	<b>17</b>
8.1	SSOP10 package information .....	17
<b>9</b>	<b>Ordering information</b> .....	<b>19</b>
<b>10</b>	<b>Revision history</b> .....	<b>20</b>

## List of tables

Table 1.	Pin descriptions . . . . .	5
Table 2.	Typical power . . . . .	6
Table 3.	Absolute maximum rating . . . . .	7
Table 4.	Thermal data . . . . .	7
Table 5.	Electrical characteristics . . . . .	9
Table 6.	SSOP10 mechanical data . . . . .	18
Table 7.	Order code . . . . .	19
Table 8.	Document revision history . . . . .	20

## List of figures

Figure 1.	VIPER122 block diagram	1
Figure 2.	Connection diagram	5
Figure 3.	$R_{th}$ vs. area	8
Figure 4.	$I_{LIM}$ vs. $T_J$	11
Figure 5.	$V_{REF}$ vs. $T_J$	11
Figure 6.	$I_{CC0}$ vs. $T_J$	11
Figure 7.	$I_{CC1}$ vs. $T_J$	11
Figure 8.	$R_{DS(on)}$ vs. $T_J$	11
Figure 9.	$V_{BVDSS}$ vs. $T_J$	11
Figure 10.	Non-isolated flyback converter	14
Figure 11.	Primary side flyback converter	14
Figure 12.	Isolated flyback converter	15
Figure 13.	Buck converter	15
Figure 14.	Buck-boost converter	16
Figure 15.	SSOP10 package outline	17
Figure 16.	SSOP10 recommended footprint	18

# 1 Pin settings

Figure 2. Connection diagram

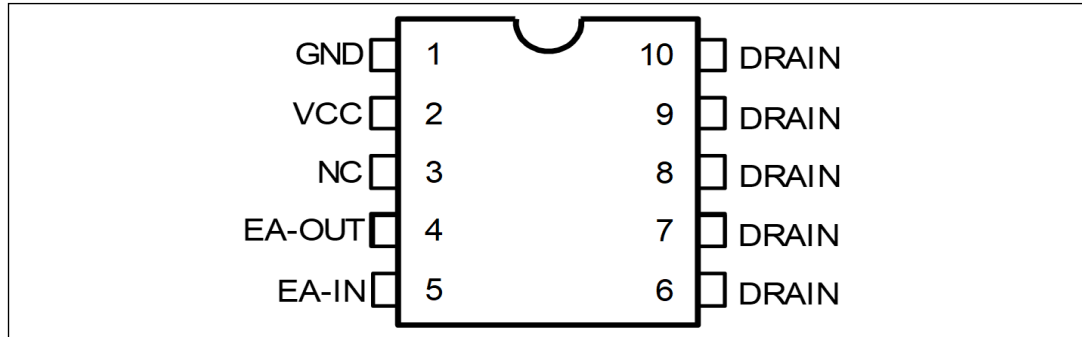

Table 1. Pin descriptions

SSOP10	Name	Function
1	GND	Connected to the source of the internal power MOSFET and controller ground reference.
2	VCC	Supply voltage of the control section. This pin provides the charging current of the external capacitor.
3	NC	Not connected. The pin must be left floating.
4	EA-OUT	Output of the error amplifier.
5	EA-IN	Input of the error amplifier.
6-10	DRAIN	High voltage drain pin. The built-in high voltage switched start-up bias current is drawn from this pin too. Connect to a PCB copper area to facilitate heat dissipation.

## 2 Typical power capability

Table 2. Typical power

$V_{IN}: 230 V_{AC}$		$V_{IN}: 85 - 265 V_{AC}$	
Adapter <sup>(1)</sup>	Open frame <sup>(2)</sup>	Adapter <sup>(1)</sup>	Open frame <sup>(2)</sup>
9 W	11 W	5 W	6 W

1. Typical continuous power in non-ventilated enclosed adapter measured at 50 °C ambient temperature.
2. Maximum practical continuous power in an open frame design at 50 °C ambient temperature, with adequate heat-sinking.

### 3 Electrical and thermal ratings

**Table 3. Absolute maximum rating**

Symbol	Pin	Parameter	Value		Unit
			Min.	Max.	
$V_{DS}$	6-10	Drain-to-source (ground) voltage	-	730	V
$I_D$	6-10	Pulse drain current (limited by $T_J = 150\text{ °C}$ )	-	2	A
$V_{EA-IN}$	5	Input pin voltage	-0.3	4.8	V
$V_{EA-OUT}$	4	Out pin voltage	-0.3	3.5	V
$V_{CC}$	2	Supply voltage	-0.3	Self limited	V
$I_{CC}$	2	Input current	-	20	mA
$P_{TOT}$	-	Power dissipation at $T_A < 50\text{ °C}$	-	1	W
$T_J$	-	Junction temperature range	-40	150	°C
$T_{STG}$	-	Storage temperature	-55	150	°C

**Table 4. Thermal data**

Symbol	Parameter	Max. value	Unit
$R_{TH-JC}$	Thermal resistance junction to case <sup>(1)</sup> (Dissipated power = 1 W)	10	°C/W
$R_{TH-JA}$	Thermal resistance junction ambient <sup>(1)</sup> (Dissipated power = 1 W)	155	°C/W
$R_{TH-JC}$	Thermal resistance junction to case <sup>(2)</sup> (Dissipated power = 1 W)	5	°C/W
$R_{TH-JA}$	Thermal resistance junction ambient <sup>(2)</sup> (Dissipated power = 1 W)	95	°C/W

1. When mounted on a standard single side FR4 board with minimum copper area.
2. When mounted on a standard single side FR4 board with 100 mm<sup>2</sup> (0.155 sq in) of Cu (35 µm thick).

Figure 3. Rth vs. area

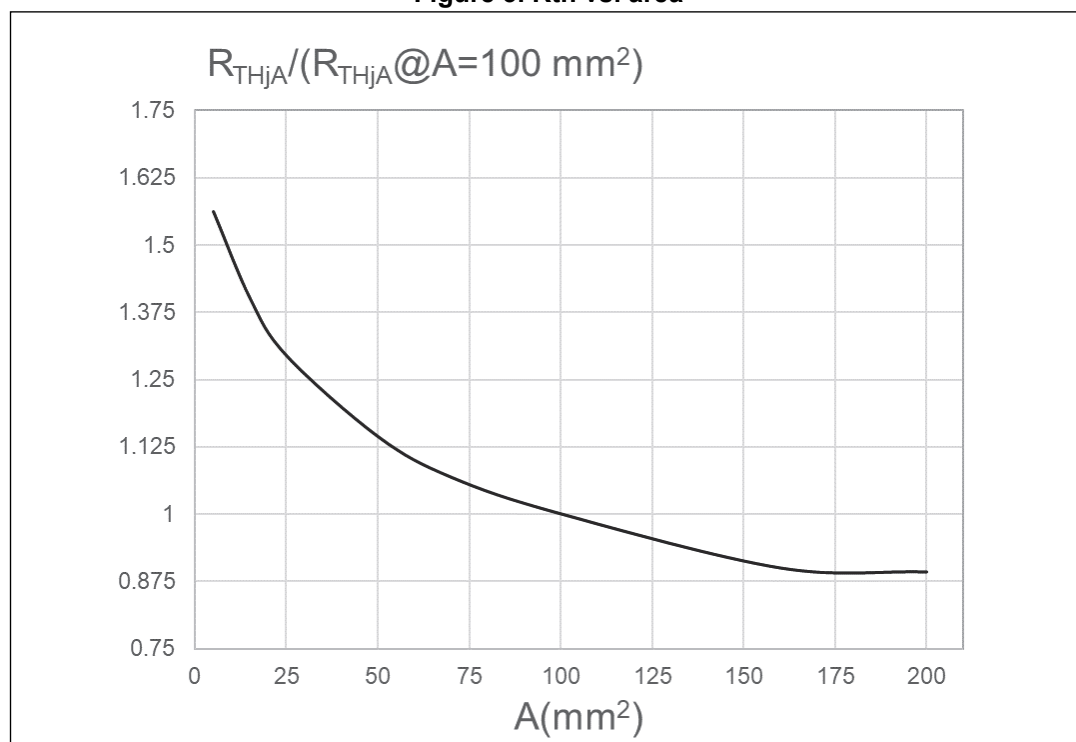



## 4 Electrical characteristics

( $T_J = 25\text{ °C}$ ,  $V_{CC} = 14\text{ V}$ , unless otherwise specified.)

**Table 5. Electrical characteristics**

Symbol	Parameter	Test Condition	Min.	Typ.	Max.	Unit
$V_{BVDSS}$	Breakdown voltage	$I_D = 1\text{ mA}$ , EA-OUT = GND	730	-	-	V
$R_{DS(on)}$	Drain-source ON state resistance	$I_D = 0.2\text{ A}$ ; $T_J = 25\text{ °C}$	-	-	27	$\Omega$
$C_{OSS}$	Effective (energy related) output capacitance	$V_{DRAIN} = 100\text{ V}^{(1)}$	-	12	-	pF
$I_{DSS}$	OFF state DRAIN leakage current	$V_{DRAIN} = 730\text{ V}$	-	-	70	$\mu\text{A}$
$V_{START}$	Drain-source start voltage	-	-	-	45	V
$I_{CH1}$	Startup charging current	$V_{DRAIN} = 100\text{ V}$ $V_{CC} = 4\text{ V}$	-0.6	-	-1.8	mA
$I_{CH2}$	Charging current during operation	$V_{DRAIN} = 100\text{ V}$ $V_{CC} = 9\text{ V}$ falling edge	-7	-	-14	mA
$V_{CC}$	Operating voltage range	-	11.5	-	23.5	V
$V_{CLAMP}$	$V_{CC}$ clamp voltage	$I_{CC} = 15\text{ mA}$	23.5	-	-	V
$V_{ON}$	$V_{CC}$ ON threshold	-	12	13	14	V
$V_{CCL}$	$V_{CC}$ low value	-	9.5	10.5	11.5	V
$V_{OFF}$	UVLO	-	7	8	9	V
$I_{CC0}$	Operating supply current, not switching	Not switching	-	-	0.7	mA
$I_{CC1}$	Operating supply current, switching	Switching	-	-	1.6	mA
$I_{CC2}$	Operating supply current, with $V_{CC} < V_{OFF}$	$V_{CC} = 6\text{ V}$	-	-	0.35	mA
$I_{CC\_FAIL}$	$V_{CC}$ clamp protection	$V_{CC} = V_{CLAMP}$ $V_{EA-OUT} = 3.3\text{ V}$	4	-	-	mA
$I_{LIM}$	Drain current limit (OCP)	$V_{EA-OUT} = 3.3\text{ V}$	0.4	0.45	0.5	A
$T_{ON(MIN)}$	Minimum turn ON time	-	-	-	450	ns
$F_{OSC}$	-	-	54	60	66	kHz
$F_D$	Modulation depth	-	-	$\pm 4$	-	kHz
$F_M$	Modulation frequency	-	-	230	-	Hz
$D_{MAX}$	Max. duty cycle	<sup>(1)</sup>	70	-	80	%
$V_{REF}$	E/A reference voltage	-	3.2	3.3	3.4	V
$I_{PULL\ UP}$	EA-IN pin current pull up	-	-	-1	-	$\mu\text{A}$

Table 5. Electrical characteristics (continued)

Symbol	Parameter	Test Condition	Min.	Typ.	Max.	Unit
$G_M$	E/A Trans conductance	(1)	-	2	-	mA/V
$V_{EA-SAT}$	EA-OUT pin saturation limit	-	-	3	-	V
$V_{EA-BM}$	Burst mode threshold	-	1	1.1	1.2	V
$V_{HYST}$	Burst mode hysteresis	-	-	40	-	mV
$R_{DYN}$	Dynamic resistance	$V_{EA-IN} = GND$	-	15	-	k $\Omega$
$H_{EA-OUT}$	$\Delta V_{EA-OUT} / \Delta I_D$	(1)	3	-	6	V/A
$I_{EA-OUT}$	EA-OUT pin source / sink current	-	-	150	-	$\mu A$
$I_{EA-OUT\_MAX}$	EA-OUT pin max. source current	-	-	220	-	$\mu A$
$T_{SD}$	Thermal shutdown temperature	(1)	150	160	-	$^{\circ}C$
$T_{HYST}$	Thermal shutdown hysteresis	(1)	-	30	-	$^{\circ}C$

1. Specification assured by characterization.

## 5 Typical electrical characteristics

Figure 4.  $I_{LIM}$  vs.  $T_J$

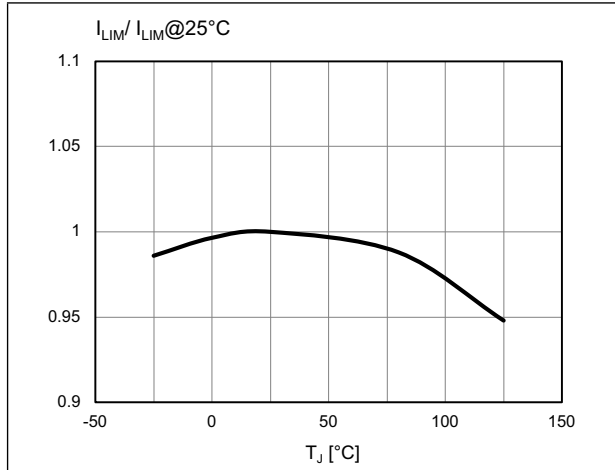

Figure 5.  $V_{REF}$  vs.  $T_J$

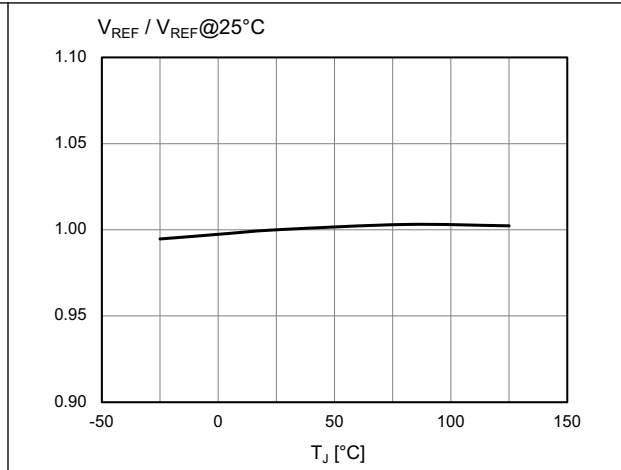

Figure 6.  $I_{CC0}$  vs.  $T_J$

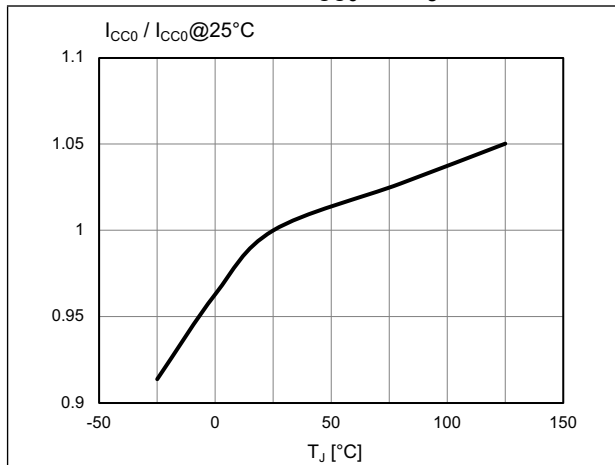

Figure 7.  $I_{CC1}$  vs.  $T_J$

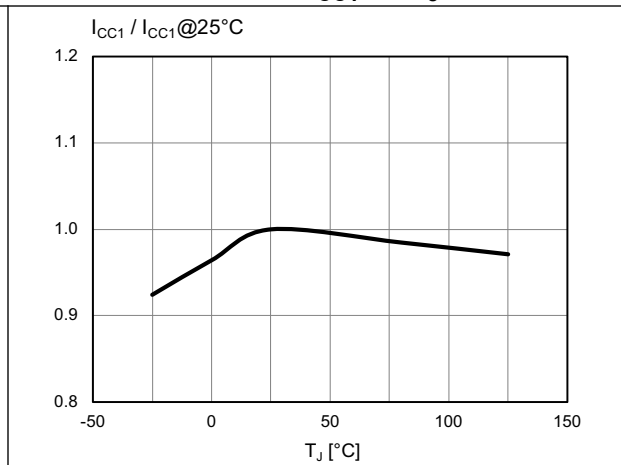

Figure 8.  $R_{DS(on)}$  vs.  $T_J$

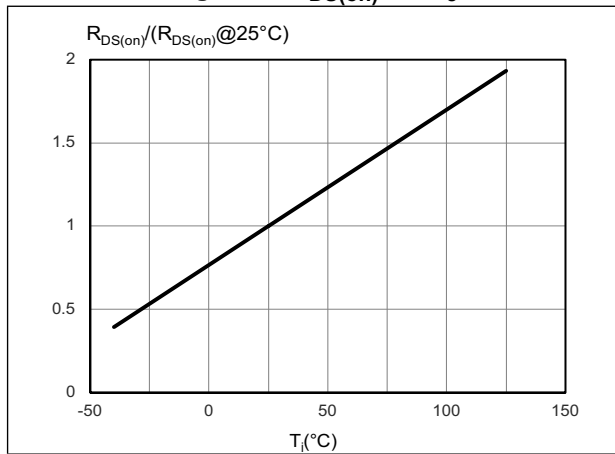
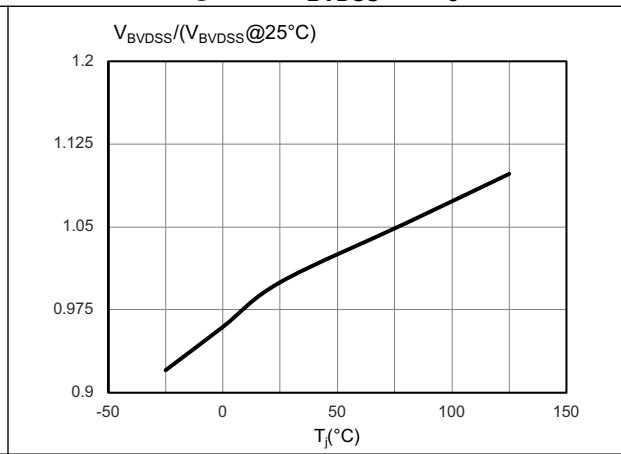

Figure 9.  $V_{BDSS}$  vs.  $T_J$



## 6 General description

The VIPER122 is a 730 V high voltage converter optimized for flyback and buck topologies that operates at 60 kHz switching frequency and integrates jittering in order to reduce EMI levels.

The low IC consumption combined with Burst Mode allows very low input power at no load and very good efficiency at light load.

### 6.1 Startup

On initial startup, the integrated high voltage current source charges the VCC capacitor. The charge current  $I_{CH1}$  is stopped as soon as the VCC voltage reaches  $V_{ON}$ .

As soon as the VCC capacitor is charged up to the  $V_{ON}$  threshold, the power MOSFET starts switching in soft-start mode and the device is either supplied from an external source (auxiliary winding or directly from the output voltage through a diode) or internally from the high voltage startup that is reactivated whenever the VCC voltage drops to the  $V_{CCL}$  level.

Soft-start is staggered over 16 steps up to the default current limit value ( $I_{LIM}$ ), over a period of 8.5 ms.

In case of fault detection, the VCC voltage moves between  $V_{ON}$  (13 V) and  $V_{CCL}$  (10.5 V) and power MOSFET switching is only interrupted if the VCC voltage falls below the  $V_{OFF}$  ( $V_{OFF}$ ) threshold, which typically occurs if the DRAIN voltage is removed.

### 6.2 Feedback loop

The device operates in current mode, so the primary current is internally sensed and converted into voltage that is applied to the non-inverting pin of the PWM comparator. The sensed voltage is compared through a voltage divider on a cycle-by-cycle basis with the voltage on the EA-IN pin.

The OCP comparator works in parallel with the PWM comparator and limits the primary current below the  $I_{LIM}$  threshold.

There are two ways to close the loop and regulate the output: through a resistor divider or an optocoupler.

#### 6.2.1 Resistor divider

For non-isolated topologies (flyback, buck or buck-boost converters), the output voltage can be directly regulated by connecting a resistor divider to the EA-IN pin that is the inverting input of the integrated error amplifier (EA).

Primary side regulation can be achieved by connecting the resistor divider from the auxiliary winding of the transformer to the EA-IN pin.

The loop compensation network is connected on the EA-OUT pin.

### 6.2.2 Optocoupler

For an isolated flyback, the EA-IN pin must be connected to ground and the optocoupler connected to the EA-OUT pin.

The EA-OUT pin dynamics range between the values  $V_{EA-SAT}$  and  $V_{EA-BM}$ : above the  $V_{EA-SAT}$  level, the primary drain current reaches its limit; below the  $V_{EA-BM}$  level, the device enters Burst Mode.

### 6.3 Burst mode at light load

When the load decreases, the feedback loop reacts by lowering the EA-OUT pin voltage. If it falls below the  $V_{EA-BM}$  threshold, power MOSFET switching is interrupted until it returns above  $V_{EA-BM} + V_{HYST}$ .

During Burst Mode, the drain current peak is clamped to about 85 mA in order to avoid audible noise due to the low switching frequency.

### 6.4 Short-circuit protection

The protection for a short-circuit is only tripped if the event persists for 50 ms. If the protection is tripped, the device stops switching for 1 second and then restarts automatically.

### 6.5 VCC clamp protection

A fault condition is detected if both of the following conditions are verified:

1. The primary drain current reaches the  $I_{LIM}$  threshold value.
2. The clamp current injected on the VCC pin reaches the  $I_{CC\_FAIL}$  threshold value.

When the protection is tripped, the device stops switching for 1 second and then restarts automatically. The device is protected in case of failure of the feedback network.

# 7 Basic application schematics

Figure 10. Non-isolated flyback converter

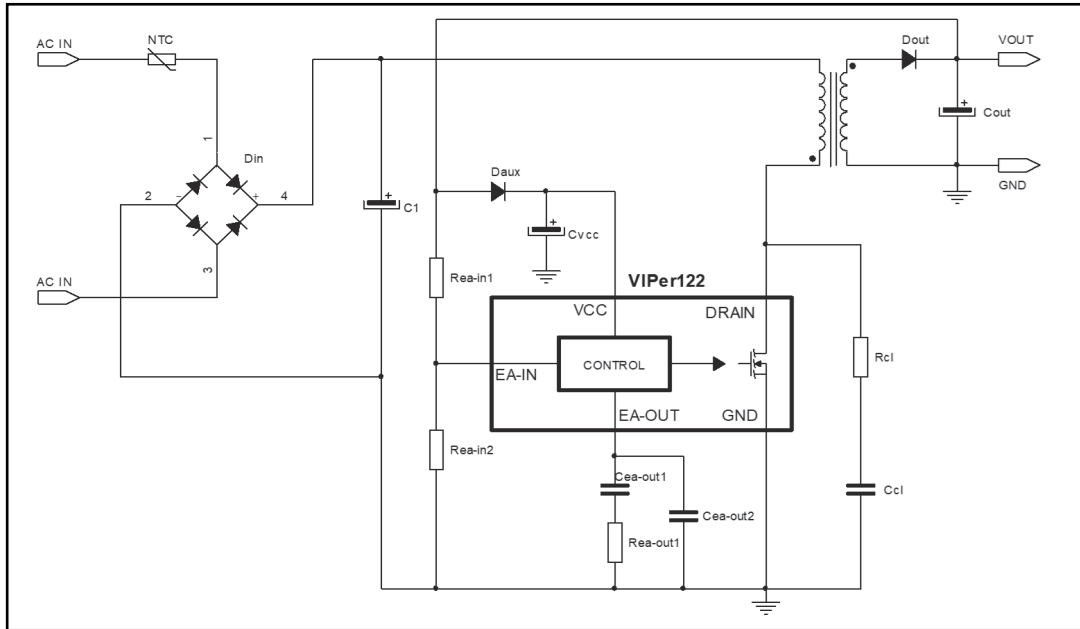

Figure 11. Primary side flyback converter

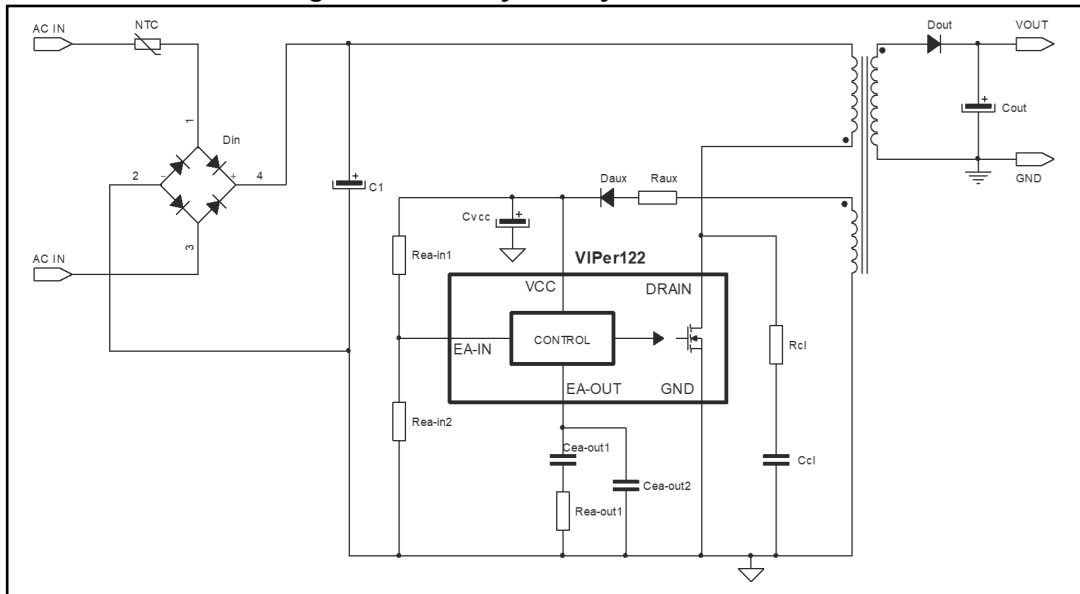

Figure 12. Isolated flyback converter

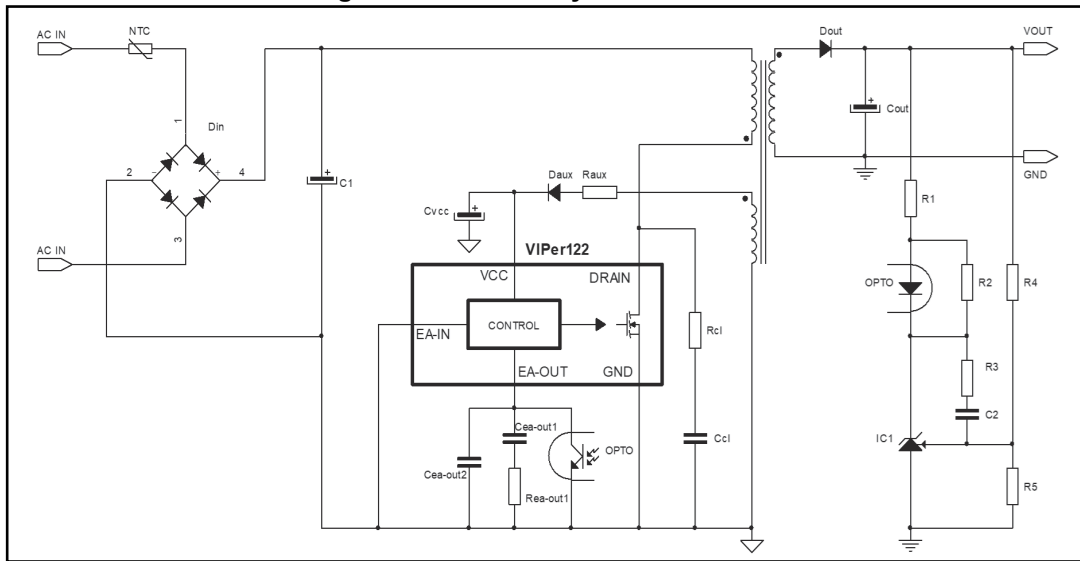

Figure 13. Buck converter

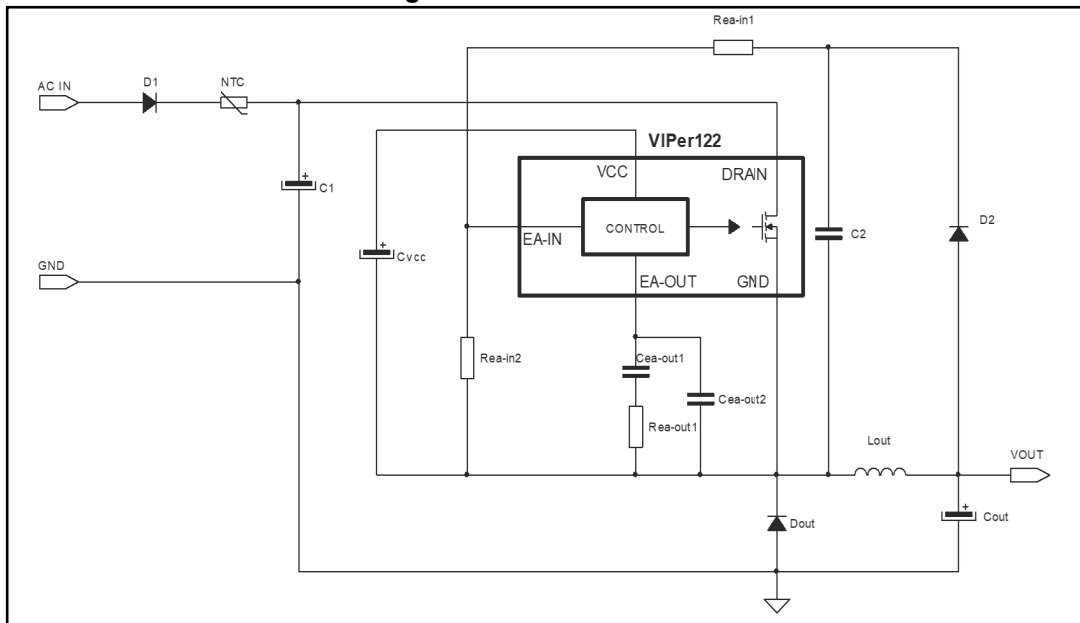
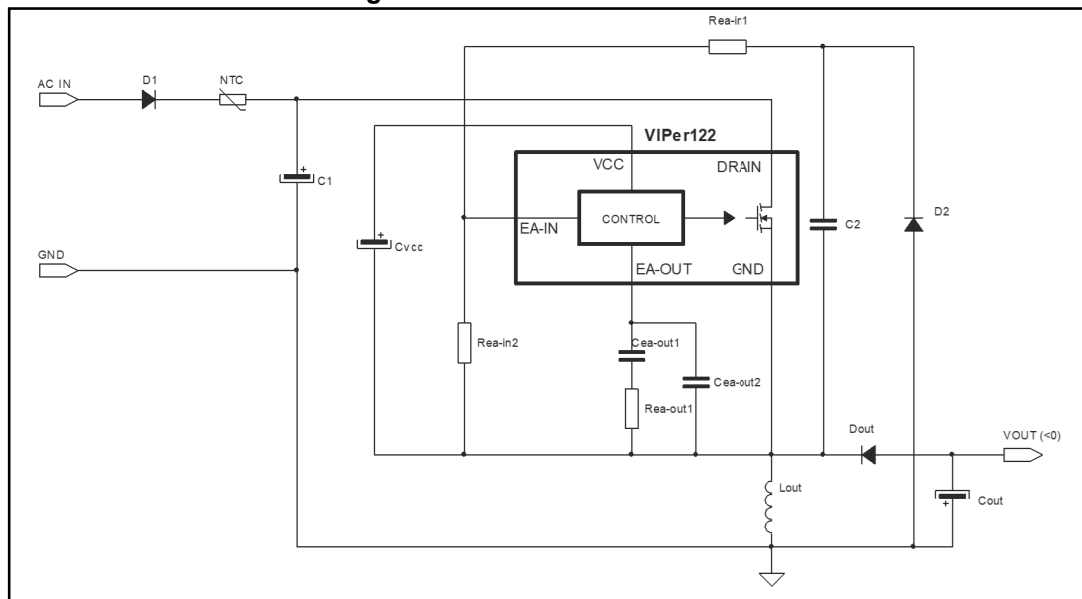

Figure 14. Buck-boost converter





## 8 Package information

In order to meet environmental requirements, ST offers these devices in different grades of ECOPACK<sup>®</sup> packages, depending on their level of environmental compliance. ECOPACK<sup>®</sup> specifications, grade definitions and product status are available at: [www.st.com](http://www.st.com). ECOPACK<sup>®</sup> is an ST trademark.

### 8.1 SSOP10 package information

Figure 15. SSOP10 package outline

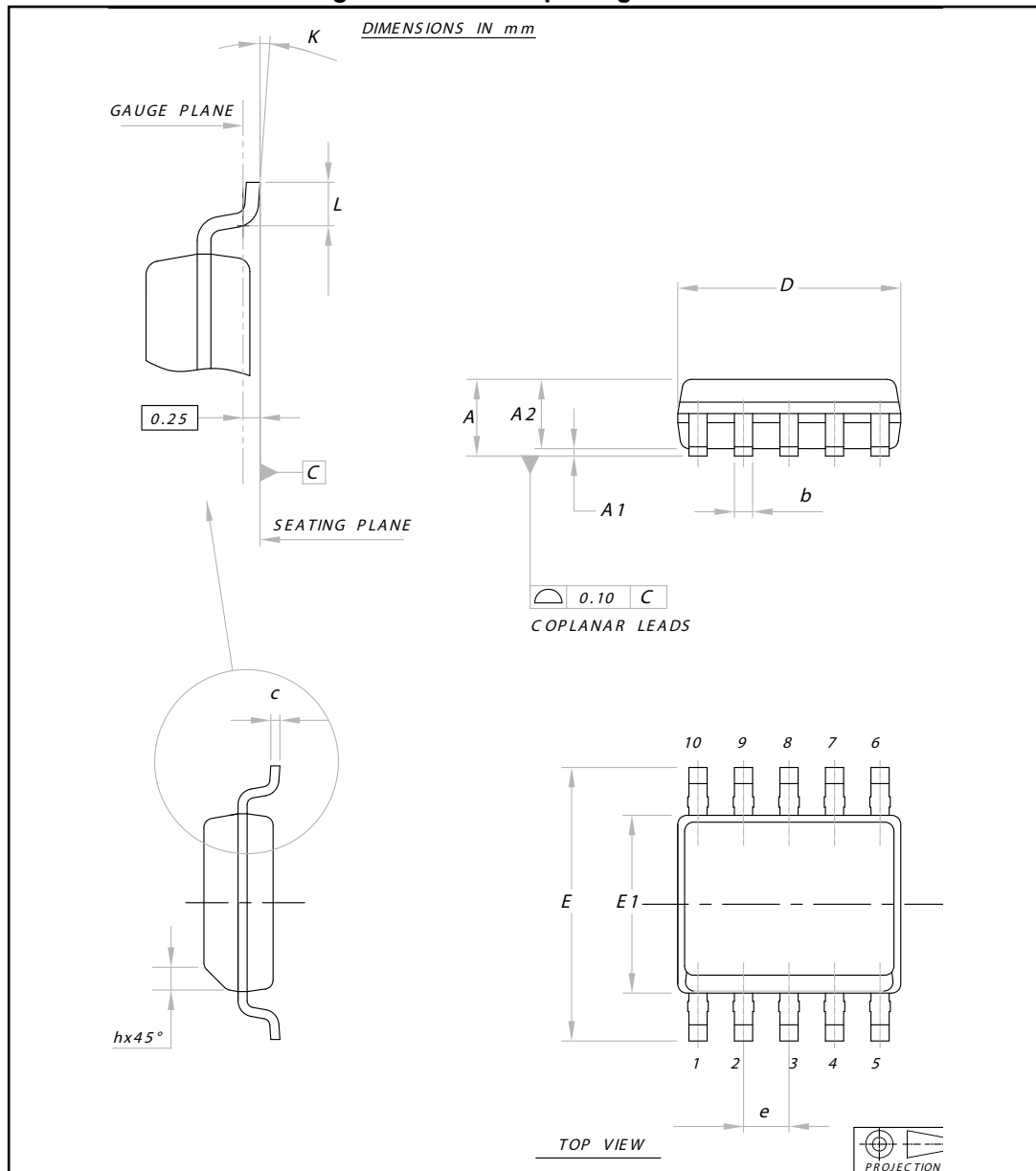
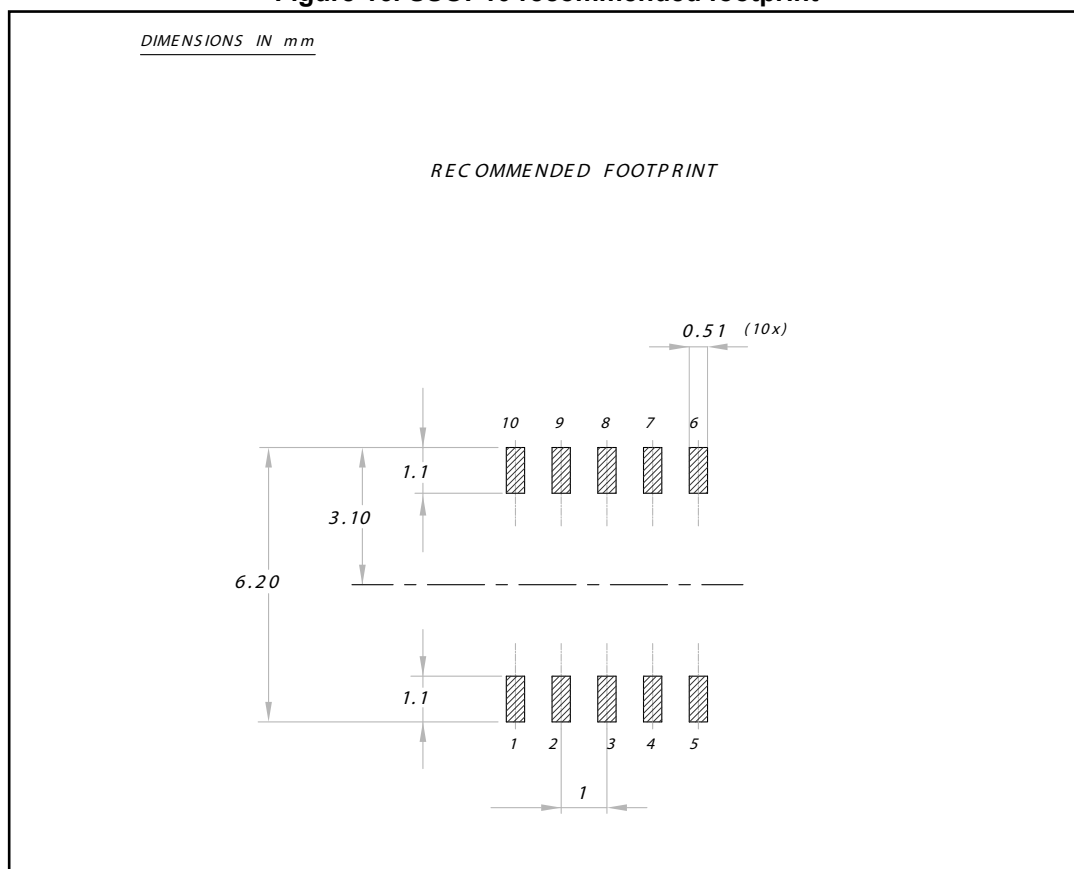

Table 6. SSOP10 mechanical data

Dim	mm		
	Min.	Typ.	Max.
A			1.75
A1	0.10		0.25
A2	1.25		
b	0.31		0.51
c	0.17		0.25
D	4.80	4.90	5
E	5.80	6	6.20
E1	3.80	3.90	4
e		1	
h	0.25		0.50
L	0.40		0.90
K	0°		8°

Figure 16. SSOP10 recommended footprint



## 9 Ordering information

Table 7. Order code

Order code	Package	Packaging
VIPER122LSTR	SSOP10	Tape & Reel

## 10 Revision history

Table 8. Document revision history

Date	Revision	Changes
4-Jun-2019	1	Initial release.

**IMPORTANT NOTICE – PLEASE READ CAREFULLY**

STMicroelectronics NV and its subsidiaries ("ST") reserve the right to make changes, corrections, enhancements, modifications, and improvements to ST products and/or to this document at any time without notice. Purchasers should obtain the latest relevant information on ST products before placing orders. ST products are sold pursuant to ST's terms and conditions of sale in place at the time of order acknowledgement.

Purchasers are solely responsible for the choice, selection, and use of ST products and ST assumes no liability for application assistance or the design of Purchasers' products.

No license, express or implied, to any intellectual property right is granted by ST herein.

Resale of ST products with provisions different from the information set forth herein shall void any warranty granted by ST for such product.

ST and the ST logo are trademarks of ST. All other product or service names are the property of their respective owners.

Information in this document supersedes and replaces information previously supplied in any prior versions of this document.

© 2019 STMicroelectronics – All rights reserved

## X-ON Electronics

Largest Supplier of Electrical and Electronic Components

*Click to view similar products for [AC/DC Converters](#) category:*

*Click to view products by [STMicroelectronics](#) manufacturer:*

Other Similar products are found below :

[ICE3AR0680VJZ](#) [ICE3AR2280CJZ](#) [ICE3BR0680JZ](#) [ICE3BR2280JZ](#) [SEA01](#) [FAN7621SSJX](#) [BP5011](#) [BP5055-12](#) [ICE2QR4780Z](#)  
[NCP1124BP100G](#) [AP3983EP7-G1](#) [ICE2QR4765](#) [TEA19363T/1J](#) [AP3125CMKTR-G1](#) [ICE3AR10080CJZ](#) [SC1076P065G](#) [47132](#) [47220](#)  
[47225](#) [APR3415BMTR-G1](#) [NCP1126BP100G](#) [HF500GP-40](#) [TNY179PN](#) [ICE3AR10080JZXKLA1](#) [BM2P0361-Z](#) [BM2P249Q-Z](#)  
[BM521Q25F-GE2](#) [INN3164C-H107-TL](#) [HR1001LGS-P](#) [BM2P131X-Z](#) [BM2P161X-Z](#) [BM2P181X-Z](#) [BM2P201X-Z](#) [BM2P241X-Z](#)  
[LNK576DG-TL](#) [INN3278C-H215-TL](#) [INN3278C-H217-TL](#) [INN3678C-H605-TL](#) [NCP1342BMDCDD1R2G](#) [AP3304AW6-7](#) [APR34910S-13](#)  
[RAC05E-05SKT](#) [TNY286PG](#) [TNY287PG](#) [TNY288DG-TL](#) [TNY288PG](#) [MP100GN](#) [HR1000AGS](#) [ICE2QR2280Z1XKLA1](#)  
[ICE2QS02GXUMA1](#)