

Breakout boards based on the VL53L1X long distance ranging Time-of-Flight sensor

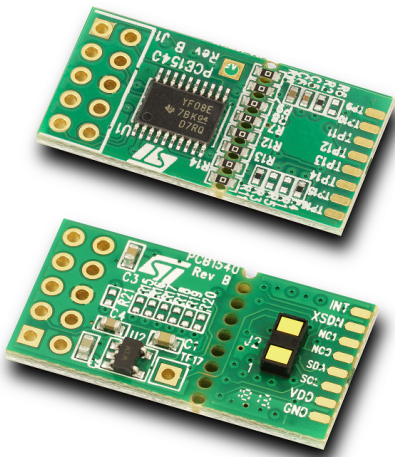

Features

- Two breakout boards, integrating:
 - VL53L1X long distance ranging Time-of-Flight (ToF) sensor
 - Regulator: 5 to 2.8 V range input voltage (output voltage: 2.8 V)
 - VL53L1X signal interface level shifter
- True distance measurement independent of target size and reflectance
- Divisible board enabling use as mini PCB breakout board, easy to integrate in customer device

Description

The VL53L1X-SATEL breakout boards can be used for easy integration into customer devices.

Thanks to the voltage regulator and level shifters, the VL53L1X breakout boards can be used in any application with a 2.8 V to 5 V supply.

The PCB section supporting the VL53L1X module is perforated so that developers can break off the mini PCB for use in a 2.8 V supply application using flying leads. This makes it easier to integrate the VL53L1X-SATEL breakout boards into development and evaluation devices due to their small form factor.

Product status link

[VL53L1X-SATEL](#)

1 VL53L1X overview

The VL53L1X is the latest product based on ST's patented FlightSense™ technology. This is a ground-breaking technology allowing absolute distance to be measured independent of target reflectance. Instead of estimating the distance by measuring the amount of light reflected back from an object (which is significantly influenced by color and surface), the VL53L1X precisely measures the time the light takes to travel to the nearest object and reflect back to the sensor (Time-of-Flight).

Combining an IR emitter and a range sensor, the VL53L1X is easy to integrate and saves OEMs long and costly optical and mechanical design optimizations.

The module is designed for low-power operations. Ranging measurements can be automatically performed at user defined intervals. Multiple threshold and interrupt schemes are supported to minimize host operations.

Note: The VL53L1X is delivered with a liner, to prevent potential foreign material to penetrate inside the module holes during the assembly process. The liner must be removed at the latest possible step during final assembly and before module calibration.

2 Breakable board

For 2.8 V supply applications, the breakout boards can be broken along the red dotted line as shown in the figure below, to use the “mini PCB”. This set up is easier to integrate into a customer device due to its small form factor.

Figure 1. Breakout board layout

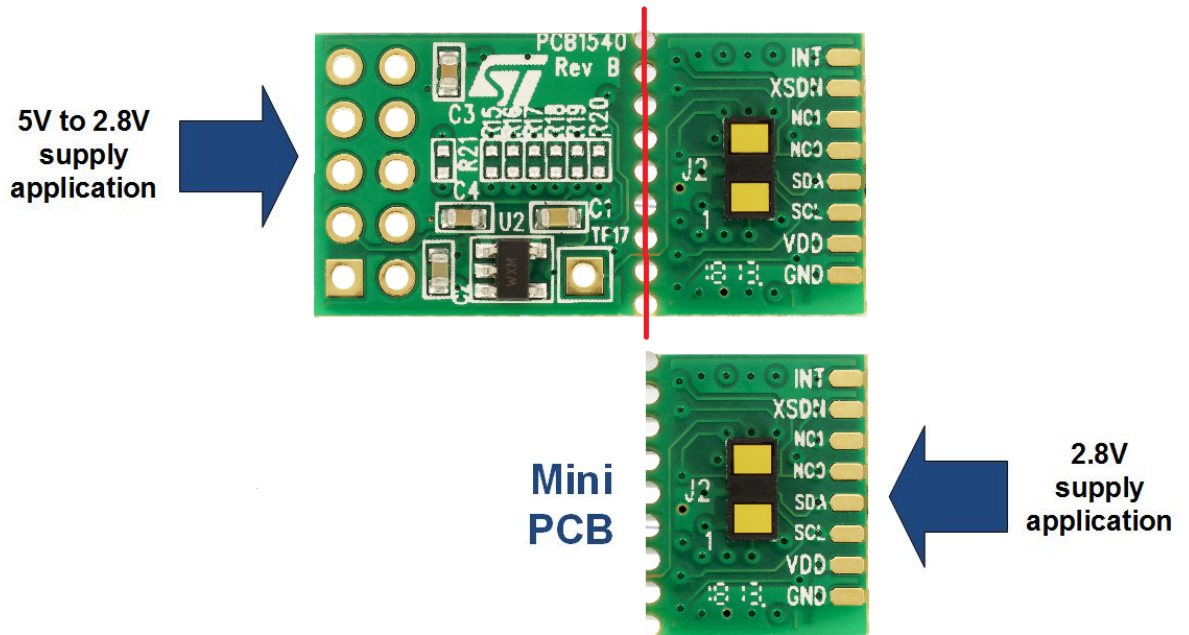

3 Schematic and list of materials

Figure 2. Satellite schematic and list of materials

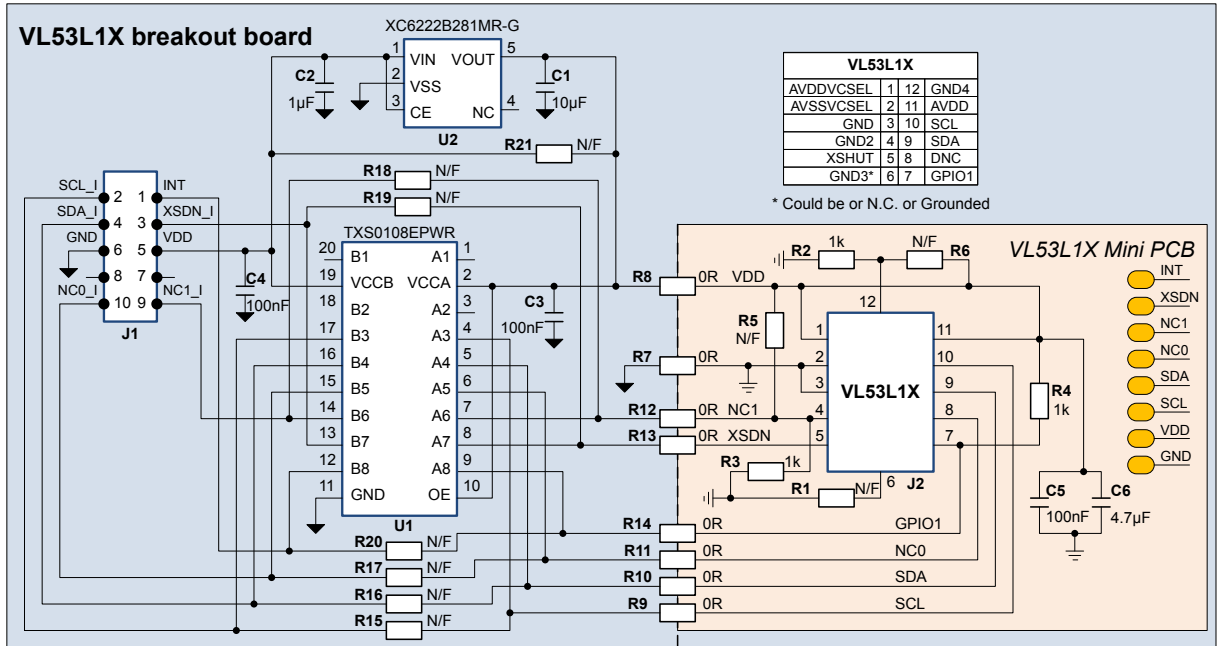

4 Ordering information

Table 1. Ordering information

Order code	Description
VL53L1X-SATEL	Two VL53L1X breakout boards

Revision history

Table 2. Document revision history

Date	Version	Changes
03-May-2018	1	Initial release
20-Feb-2019	2	Updated cover image and Figure 1. Breakout board layout .

IMPORTANT NOTICE – PLEASE READ CAREFULLY

STMicroelectronics NV and its subsidiaries (“ST”) reserve the right to make changes, corrections, enhancements, modifications, and improvements to ST products and/or to this document at any time without notice. Purchasers should obtain the latest relevant information on ST products before placing orders. ST products are sold pursuant to ST’s terms and conditions of sale in place at the time of order acknowledgement.

Purchasers are solely responsible for the choice, selection, and use of ST products and ST assumes no liability for application assistance or the design of Purchasers’ products.

No license, express or implied, to any intellectual property right is granted by ST herein.

Resale of ST products with provisions different from the information set forth herein shall void any warranty granted by ST for such product.

ST and the ST logo are trademarks of ST. All other product or service names are the property of their respective owners.

Information in this document supersedes and replaces information previously supplied in any prior versions of this document.

© 2019 STMicroelectronics – All rights reserved

X-ON Electronics

Largest Supplier of Electrical and Electronic Components

Click to view similar products for [Distance Sensor Development Tool](#) category:

Click to view products by [STMicroelectronics](#) manufacturer:

Other Similar products are found below :

[SEN0004](#) [MIKROE-2509](#) [172](#) [DFR0315](#) [SEN0006](#) [SEN0007](#) [SEN0008](#) [SEN0187](#) [SEN0202](#) [SEN0208](#) [DM160234](#) [SEN0143](#) [3316](#) [SEN-08504](#) [SEN-08502](#) [DFR0445](#) [3317](#) [984](#) [SEN0014](#) [SEN0001](#) [SEN0171](#) [3942](#) [979](#) [981](#) [982](#) [985](#) [AFBR-S50MV85G-EK](#) [TMF8701-DB](#) [TMF8801-DB](#) [TMF8801-EVM](#) [AD8283CP-EBZ](#) [AD8285CP-EBZ](#) [ADUX1020-EVAL-SDP](#) [SEN0245](#) [EVALBGT24LTR22TOBO1](#) [DM160238](#) [MIKROE-3339](#) [MIKROE-3439](#) [MIKROE-1589](#) [MIKROE-1991](#) [MIKROE-2086](#) [MIKROE-3103](#) [SECO-RANGEFINDER-GEVK](#) [PIM058](#) [PIM062](#) [PIM373](#) [101020083](#) [101020353](#) [101020532](#) [101020617](#)