

## Single channel high-side driver with analog current sense for automotive applications

Datasheet - production data

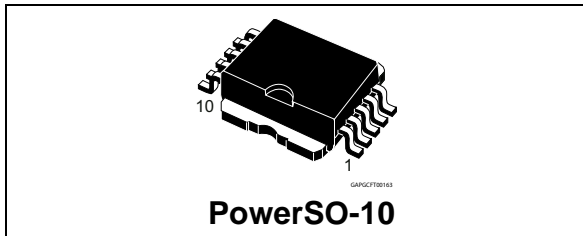

### Features

Max transient supply voltage	$V_{CC}$	41 V
Operating voltage range	$V_{CC}$	4.5 to 28 V
Max on-state resistance (per ch.)	$R_{ON}$	6 m $\Omega$
Current limitation (typ)	$I_{LIMH}$	90 A
Off-state supply current	$I_S$	2 $\mu$ A <sup>(1)</sup>

1. Typical value with all loads connected.

- General
  - Very low standby current
  - 3.0 V CMOS compatible inputs
  - Optimized electromagnetic emissions
  - Very low electromagnetic susceptibility
  - Compliance with European directive 2002/95/EC
  - Very low current sense leakage
- Diagnostic functions
  - Proportional load current sense
  - High current sense precision for wide currents range
  - Diagnostic enable pin
  - Off-state open-load detection
  - Output short to  $V_{CC}$  detection
  - Overload and short to ground (power limitation) indication
  - Thermal shutdown indication
- Protection
  - Inrush current active management by power limitation

- Undervoltage shutdown
- Overvoltage clamp
- Load current limitation
- Self limiting of fast thermal transients
- Protection against loss of ground and loss of  $V_{CC}$
- Overtemperature shutdown with auto restart (thermal shutdown)
- Reverse battery protected with self switch of the Power MOSFET
- Electrostatic discharge protection

### Applications

- All types of resistive, inductive and capacitive loads

### Description

The VN5E006ASP-E is a single channel high-side driver manufactured using ST proprietary VIPower<sup>®</sup> M0-5 technology and housed in PowerSO-10 package. The device is designed to drive 12 V automotive grounded loads delivering protection, diagnostics. It also implements a 3 V and 5 V CMOS-compatible interface for use with any microcontroller.

The device integrates advanced protective functions such as load current limitation, inrush and overload active management by power limitation, overtemperature shut-off with auto-restart and overvoltage active clamp. A dedicated analog current sense pin is associated with every output channel providing enhanced diagnostic functions including fast detection of overload and short-circuit to ground through power limitation indication, over-temperature indication, short-circuit to  $V_{CC}$  diagnosis and on-state and off-state open-load detection. The current sensing and diagnostic feedback of the whole device can be disabled by pulling the DE pin low to share the external sense resistor with similar devices.

# Contents

<b>1</b>	<b>Block diagram and pin description</b>	<b>5</b>
<b>2</b>	<b>Electrical specifications</b>	<b>7</b>
2.1	Absolute maximum ratings	7
2.2	Thermal data	8
2.3	Electrical characteristics	9
2.4	Waveforms	18
2.5	Electrical characteristics curves	21
<b>3</b>	<b>Application information</b>	<b>24</b>
3.1	MCU I/Os protection	24
3.2	Load dump protection	24
3.3	Current sense and diagnostic	25
3.3.1	Short to VCC and off-state open-load detection	26
3.4	Maximum demagnetization energy ( $V_{CC} = 13.5\text{ V}$ )	27
<b>4</b>	<b>Package and PCB thermal data</b>	<b>28</b>
4.1	PowerSO-10 thermal data	28
<b>5</b>	<b>Package information</b>	<b>31</b>
5.1	ECOPACK <sup>®</sup> packages	31
5.2	PowerSO-10 mechanical data	32
5.3	Packing information	34
<b>6</b>	<b>Order codes</b>	<b>35</b>
<b>7</b>	<b>Revision history</b>	<b>36</b>

## List of tables

Table 1.	Pin function . . . . .	5
Table 2.	Suggested connections for unused and not connected pins . . . . .	6
Table 3.	Absolute maximum ratings . . . . .	7
Table 4.	Thermal data . . . . .	8
Table 5.	Power section . . . . .	9
Table 6.	Switching ( $V_{CC} = 13\text{ V}$ ; $T_j = 25\text{ °C}$ ) . . . . .	9
Table 7.	Logic inputs . . . . .	10
Table 8.	Protections and diagnostic . . . . .	10
Table 9.	Current sense ( $8\text{ V} < V_{CC} < 18\text{ V}$ ) . . . . .	11
Table 10.	Open-load detection ( $8\text{ V} < V_{CC} < 18\text{ V}$ , $V_{DE} = 5\text{ V}$ ) . . . . .	12
Table 11.	Truth table . . . . .	16
Table 12.	Electrical transient requirements (part 1) . . . . .	17
Table 13.	Electrical transient requirements (part 2) . . . . .	17
Table 14.	Electrical transient requirements (part 3) . . . . .	17
Table 15.	Thermal parameter . . . . .	30
Table 16.	PowerSO-10 mechanical data . . . . .	33
Table 17.	Device summary . . . . .	35
Table 18.	Document revision history . . . . .	36

## List of figures

Figure 1.	Block diagram . . . . .	5
Figure 2.	Configuration diagram (top view) . . . . .	6
Figure 3.	Current and voltage conventions . . . . .	7
Figure 4.	Current sense delay characteristics . . . . .	13
Figure 5.	Open load Off-state delay timing . . . . .	13
Figure 6.	Switching characteristics . . . . .	13
Figure 7.	Delay response time between rising edge of output current and rising edge of current sense (CS enabled) . . . . .	14
Figure 8.	Output voltage drop limitation . . . . .	14
Figure 9.	$I_{OUT}/I_{SENSE}$ vs $I_{OUT}$ . . . . .	15
Figure 10.	Maximum current sense ratio drift vs load current . . . . .	15
Figure 11.	Normal operation . . . . .	18
Figure 12.	Overload or short to GND . . . . .	18
Figure 13.	Intermittent overload . . . . .	19
Figure 14.	OFF-state open load with external circuitry . . . . .	19
Figure 15.	Short to $V_{CC}$ . . . . .	20
Figure 16.	$T_j$ evolution in overload or short to GND . . . . .	20
Figure 17.	Off-state output current . . . . .	21
Figure 18.	High level input current . . . . .	21
Figure 19.	Input clamp voltage . . . . .	21
Figure 20.	Input high level . . . . .	21
Figure 21.	Input low level . . . . .	21
Figure 22.	Input hysteresis voltage . . . . .	21
Figure 23.	On-state resistance vs $T_{case}$ . . . . .	22
Figure 24.	On state resistance vs $V_{CC}$ . . . . .	22
Figure 25.	Undervoltage shutdown . . . . .	22
Figure 26.	$I_{LIMH}$ vs $T_{case}$ . . . . .	22
Figure 27.	Turn-on voltage slope . . . . .	22
Figure 28.	Turn-off voltage slope . . . . .	22
Figure 29.	DE clamp voltage . . . . .	23
Figure 30.	Low level DE voltage . . . . .	23
Figure 31.	High level DE voltage . . . . .	23
Figure 32.	Application schematic . . . . .	24
Figure 33.	Current sense and diagnostics . . . . .	25
Figure 34.	Maximum turn-off current versus inductance . . . . .	27
Figure 35.	PowerSO-10 PC board . . . . .	28
Figure 36.	$R_{thj-amb}$ vs PCB copper area in open box free air condition (one channel on) . . . . .	28
Figure 37.	PowerSO-10 thermal impedance junction ambient single pulse (one channel on) . . . . .	29
Figure 38.	Thermal fitting model of a single channel HSD in PowerSO-10 . . . . .	29
Figure 39.	PowerSO-10 package dimensions . . . . .	32
Figure 40.	PowerSO-10 suggested pad layout and tube shipment (no suffix) . . . . .	34
Figure 41.	PowerSO-10 tape and reel shipment (suffix "TR") . . . . .	34

# 1 Block diagram and pin description

Figure 1. Block diagram

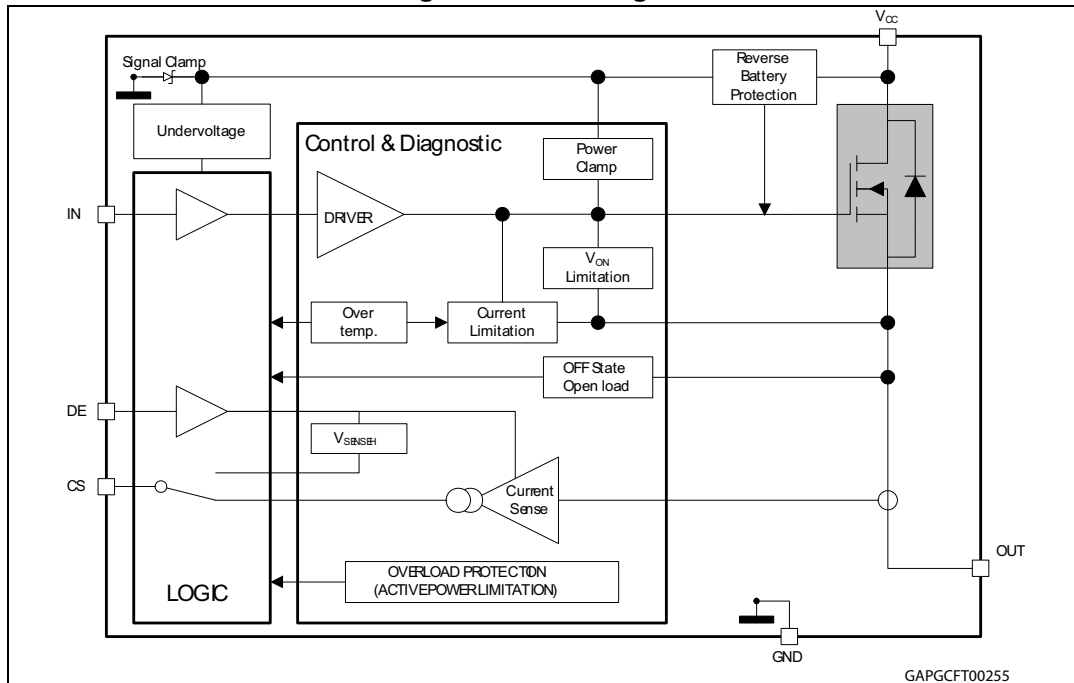

Table 1. Pin function

Name	Function
V <sub>CC</sub>	Battery connection.
OUTPUT	Power output.
GND	Ground connection.
INPUT	Voltage controlled input pin with hysteresis, CMOS compatible. Controls output switch state.
CURRENT SENSE	Analog current sense pin, delivers a current proportional to the load current.
DE	Active high diagnostic enable pin.

Figure 2. Configuration diagram (top view)

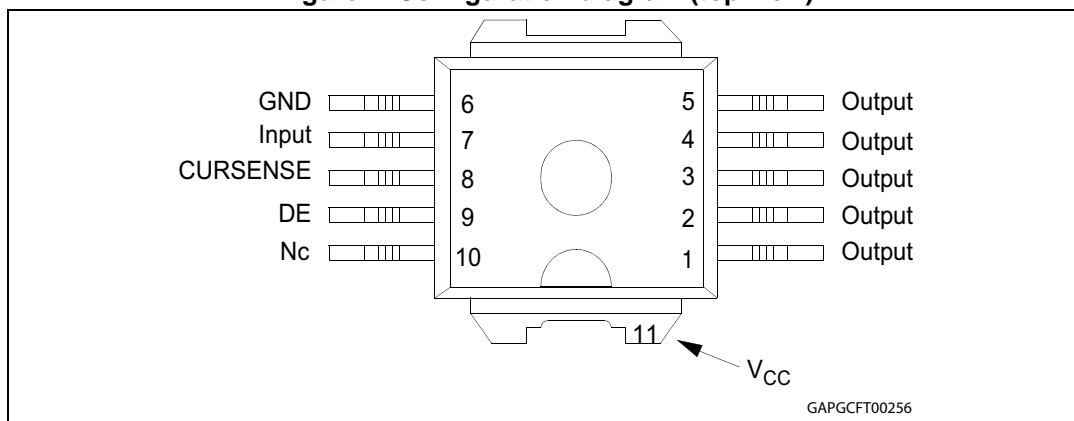
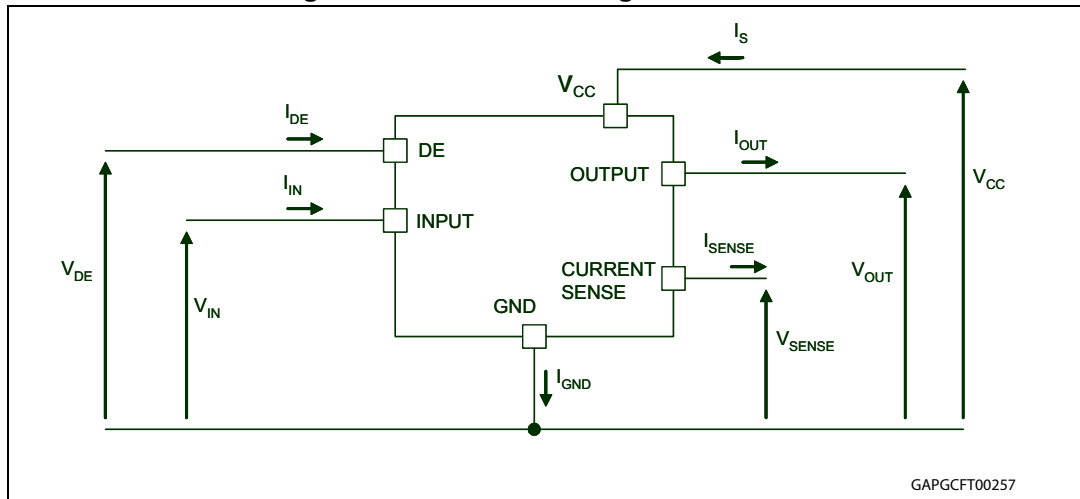

Table 2. Suggested connections for unused and not connected pins

Connection / pin	Current sense	N.C.	Output	Input	DE
Floating	Not allowed	X	X	X	X
To ground	Through 1K $\Omega$ resistor	X	Not allowed	Through 10K $\Omega$ resistor	Through 10K $\Omega$ resistor

## 2 Electrical specifications

Figure 3. Current and voltage conventions



### 2.1 Absolute maximum ratings

Stressing the device above the ratings listed in [Table 3](#) may cause permanent damage to the device. These are stress ratings only and operation of the device at these or any other conditions above those indicated in the Operating sections of this specification is not implied. Exposure to the conditions in this section for extended periods may affect device reliability.

Table 3. Absolute maximum ratings

Symbol	Parameter	Value	Unit
$V_{CC}$	DC supply voltage	28	V
$V_{CCPK}$	Transient supply voltage ( $T < 400$ ms, $R_{LOAD} > 0.5 \Omega$ )	41	V
$-V_{CC}$	Reverse DC supply voltage	16	V
$I_{OUT}$	DC output current	Internally limited	A
$-I_{OUT}$	Reverse DC output current	60	A
$I_{IN}$	DC input current	-1 to 10	mA
$I_{DE}$	DC diagnostic enable input current	-1 to 10	mA
$V_{CSENSE}$	Current sense maximum voltage	$V_{CC}-41$ $+V_{CC}$	V V
$E_{MAX}$	Maximum switching energy (single pulse) ( $L = 1.4$ mH; $R_L = 0 \Omega$ ; $V_{bat} = 13.5$ V; $T_{jstart} = 150$ °C; $I_{OUT} = I_{limL}(Typ.)$ )	600	mJ
$V_{ESD}$	Electrostatic discharge (Human Body Model: $R = 1.5$ K $\Omega$ ; $C = 100$ pF)	2000	V
$V_{ESD}$	Charge device model (CDM-AEC-Q100-011)	750	V

Table 3. Absolute maximum ratings (continued)

Symbol	Parameter	Value	Unit
$T_j$	Junction operating temperature	-40 to 150	°C
$T_{STG}$	Storage temperature	-55 to 150	°C

## 2.2 Thermal data

Table 4. Thermal data

Symbol	Parameter	Maximum value	Unit
$R_{thj-case}$	Thermal resistance junction-case (one channel ON)	0.45	°C/W
$R_{thj-amb}$	Thermal resistance junction-ambient	See <a href="#">Figure 36</a> in the thermal section	°C/W



## 2.3 Electrical characteristics

$8\text{ V} < V_{CC} < 28\text{ V}$ ;  $-40\text{ °C} < T_j < 150\text{ °C}$ , unless otherwise specified.

**Table 5. Power section**

Symbol	Parameter	Test conditions	Min	Typ	Max	Unit
$V_{CC}$	Operating supply voltage		4.5	13	28	V
$V_{USD}$	Undervoltage shutdown			3.5	4.5	V
$V_{USDhyst}$	Undervoltage shutdown hysteresis			0.5		V
$R_{ON}$	ON state resistance	$I_{OUT} = 10\text{ A}$ ; $T_j = 25\text{ °C}$		4.5		m $\Omega$
		$I_{OUT} = 10\text{ A}$ ; $T_j = 150\text{ °C}$			9	
		$I_{OUT} = 10\text{ A}$ ; $V_{CC} = 5\text{ V}$ ; $T_j = 25\text{ °C}$			6	
$R_{ON\ REV}$	Reverse battery on state resistance	$V_{CC} = -13\text{ V}$ ; $I_{OUT} = -10\text{ A}$ ; $T_j = 25\text{ °C}$			6	m $\Omega$
$V_{clamp}$	Clamp voltage	$I_S = 20\text{ mA}$	41	46	52	V
$I_S$	Supply current	Disable $V_{DE} = 0\text{ V}$ ; $V_{CC} = 13\text{ V}$ ; $T_j = 25\text{ °C}$ ; $V_{IN}=x$ ; $V_{OUT} = V_{SENSE} = 0\text{ V}$		2	5	$\mu\text{A}$
		Off state; $V_{CC} = 13\text{ V}$ ; $V_{DE} = 5\text{ V}$ ; $T_j = 25\text{ °C}$ ; $V_{IN} = V_{OUT} = V_{SENSE} = 0\text{ V}$		10 <sup>(1)</sup>	15 <sup>(1)</sup>	
		On state; $V_{CC} = 13\text{ V}$ ; $V_{DE} = 5\text{ V}$ ; $V_{IN} = 5\text{ V}$ ; $I_{OUT} = 0\text{ A}$		2	4	mA
$I_{L(off1)}$	Off state output current <sup>(2)</sup>	$V_{IN} = V_{OUT} = 0\text{ V}$ ; $V_{CC} = 13\text{ V}$ ; $T_j = 25\text{ °C}$	0	0.01	3	$\mu\text{A}$
		$V_{IN} = V_{OUT} = 0\text{ V}$ ; $V_{CC} = 13\text{ V}$ ; $T_j = 125\text{ °C}$	0		5	

1. PowerMOS leakage included.

2. For each channel.

**Table 6. Switching ( $V_{CC} = 13\text{ V}$ ;  $T_j = 25\text{ °C}$ )**

Symbol	Parameter	Test conditions	Min.	Typ.	Max.	Unit
$t_{d(on)}$	Turn-on delay time	$R_L = 1.3\ \Omega$ (see <a href="#">Figure 6</a> )	—	30	—	$\mu\text{s}$
$t_{d(off)}$	Turn-off delay time	$R_L = 1.3\ \Omega$ (see <a href="#">Figure 6</a> )	—	30	—	$\mu\text{s}$
$(dV_{OUT}/dt)_{on}$	Turn-on voltage slope	$R_L = 1.3\ \Omega$	—	See <a href="#">Figure 27</a>	—	V/ $\mu\text{s}$
$(dV_{OUT}/dt)_{off}$	Turn-off voltage slope	$R_L = 1.3\ \Omega$	—	See <a href="#">Figure 28</a>	—	V/ $\mu\text{s}$
$W_{ON}$	Switching energy losses during $t_{won}$	$R_L = 1.3\ \Omega$ (see <a href="#">Figure 6</a> )	—	3	—	mJ
$W_{OFF}$	Switching energy losses during $t_{woff}$	$R_L = 1.3\ \Omega$ (see <a href="#">Figure 6</a> )	—	1.5	—	mJ

Table 7. Logic inputs

Symbol	Parameter	Test conditions	Min.	Typ.	Max.	Unit
$V_{IL}$	Input low level voltage				0.9	V
$I_{IL}$	Low level input current	$V_{IN} = 0.9\text{ V}$	1			$\mu\text{A}$
$V_{IH}$	Input high level voltage		2.1			V
$I_{IH}$	High level input current	$V_{IN} = 2.1\text{ V}$			10	$\mu\text{A}$
$V_{I(hyst)}$	Input hysteresis voltage		0.25			V
$V_{ICL}$	Input clamp voltage	$I_{IN} = 1\text{ mA}$	5.5		7	V
		$I_{IN} = -1\text{ mA}$		-0.7		
$V_{DEL}$	DE low level voltage				0.9	V
$I_{DEL}$	DE low level current	$V_{IN} = 0.9\text{ V}$	1			$\mu\text{A}$
$V_{DEH}$	DE high level voltage		2.1			V
$I_{DEH}$	DE high level current	$V_{IN} = 2.1\text{ V}$			10	$\mu\text{A}$
$V_{DE(hyst)}$	DE hysteresis voltage		0.25			V
$V_{DECL}$	DE clamp voltage	$I_{DE} = 1\text{ mA}$	5.5		7	V
		$I_{DE} = -1\text{ mA}$		-0.7		

Table 8. Protections and diagnostic<sup>(1)</sup>

Symbol	Parameter	Test conditions	Min.	Typ.	Max.	Unit
$I_{limH}$	Short circuit current	$V_{CC} = 13\text{ V}$	63.5	90	127	A
		$5\text{ V} < V_{CC} < 24\text{ V}$			127	
$I_{limL}$	Short circuit current during thermal cycling	$V_{CC} = 13\text{ V}; T_R < T_j < T_{TSD}$		25		A
$T_{TSD}$	Shutdown temperature		150	175	200	$^{\circ}\text{C}$
$T_R$	Reset temperature		$T_{RS} + 1$	$T_{RS} + 5$		$^{\circ}\text{C}$
$T_{RS}$	Thermal reset of status		135			$^{\circ}\text{C}$
$T_{HYST}$	Thermal hysteresis ( $T_{TSD} - T_R$ )			7		$^{\circ}\text{C}$
$V_{DEMAG}$	Turn-off output voltage clamp	$I_{OUT} = 2\text{ A}; V_{IN} = 0; L = 6\text{ mH}$	$V_{CC} - 28$	$V_{CC} - 31$	$V_{CC} - 35$	V
$V_{ON}$	Output voltage drop limitation	$I_{OUT} = 1.2\text{ A}; T_j = -40\text{ }^{\circ}\text{C} \dots 150\text{ }^{\circ}\text{C}$ (see <a href="#">Figure 8</a> )		25		mV

1. To ensure long term reliability under heavy overload or short circuit conditions, protection and related diagnostic signals must be used together with a proper software strategy. If the device is subjected to abnormal conditions, this software must limit the duration and number of activation cycles.

Table 9. Current sense (8 V < V<sub>CC</sub> < 18 V)

Symbol	Parameter	Test conditions	Min	Typ	Max	Unit
K <sub>0</sub>	I <sub>OUT</sub> /I <sub>SENSE</sub>	I <sub>OUT</sub> = 5 A; V <sub>SENSE</sub> = 0.5 V; V <sub>DE</sub> = 5 V; T <sub>j</sub> = -40 °C...150 °C	7350	10700	14590	
dK <sub>0</sub> /K <sub>0</sub> <sup>(1)</sup>	Current sense ratio drift	I <sub>OUT</sub> = 5 A; V <sub>SENSE</sub> = 0.5 V; V <sub>DE</sub> = 5 V; T <sub>j</sub> = -40 °C to 150 °C	-12		12	%
K <sub>1</sub>	I <sub>OUT</sub> /I <sub>SENSE</sub>	I <sub>OUT</sub> = 10 A; V <sub>SENSE</sub> = 4 V V <sub>DE</sub> = 5 V T <sub>j</sub> = -40 °C...150 °C T <sub>j</sub> = 25 °C...150 °C	7490 8240	10500 10500	13930 12815	
dK <sub>1</sub> /K <sub>1</sub> <sup>(1)</sup>	Current sense ratio drift	I <sub>OUT</sub> = 10 A; V <sub>SENSE</sub> = 4 V; V <sub>DE</sub> = 5 V; T <sub>j</sub> = -40 °C to 150 °C	-12		12	%
K <sub>2</sub>	I <sub>OUT</sub> /I <sub>SENSE</sub>	I <sub>OUT</sub> = 15 A; V <sub>SENSE</sub> = 4 V V <sub>DE</sub> = 5 V T <sub>j</sub> = -40 °C...150 °C T <sub>j</sub> = 25 °C...150 °C	8340 8680	10400 10400	12760 12070	
dK <sub>2</sub> /K <sub>2</sub> <sup>(1)</sup>	Current sense ratio drift	I <sub>OUT</sub> = 15 A; V <sub>SENSE</sub> = 4 V; V <sub>DE</sub> = 5 V; T <sub>j</sub> = -40 °C to 150 °C	-8		8	%
K <sub>3</sub>	I <sub>OUT</sub> /I <sub>SENSE</sub>	I <sub>OUT</sub> = 25 A; V <sub>SENSE</sub> = 4 V V <sub>DE</sub> = 5 V T <sub>j</sub> = -40 °C...150 °C T <sub>j</sub> = 25 °C...150 °C	8785 8965	10300 10300	11950 11545	
dK <sub>3</sub> /K <sub>3</sub> <sup>(1)</sup>	Current sense ratio drift	I <sub>OUT</sub> = 25 A; V <sub>SENSE</sub> = 4 V; V <sub>DE</sub> = 5 V; T <sub>j</sub> = -40 °C to 150 °C	-6		6	%
I <sub>SENSE0</sub>	Analog sense leakage current	I <sub>OUT</sub> = 0 A; V <sub>SENSE</sub> = 0 V; V <sub>DE</sub> = 0 V; V <sub>IN</sub> = 0 V; T <sub>j</sub> = -40 °C...150 °C	0		1	μA
		I <sub>OUT</sub> = 0 A; V <sub>DE</sub> = 5 V; V <sub>IN</sub> = 5 V; V <sub>SENSE</sub> = 0 V T <sub>j</sub> = -40 °C...150 °C	0		2	
		I <sub>OUT</sub> = 10 A; V <sub>DE</sub> = 0 V; V <sub>SENSE</sub> = 0 V; V <sub>IN</sub> = 5 V;	0		1	
I <sub>OL</sub>	Open-load on state current detection threshold	V <sub>IN</sub> = 0 V, 8 V < V <sub>CC</sub> < 18 V; I <sub>SENSE</sub> = 5 μA	10		100	mA
V <sub>SENSE</sub>	Max analog sense output voltage	I <sub>OUT</sub> = 25 A; V <sub>DE</sub> = 5 V; R <sub>SENSE</sub> = 3.9 KΩ	5			V
V <sub>SENSEH</sub> <sup>(2)</sup>	Analog sense output voltage in fault conditions	V <sub>CC</sub> = 13 V; R <sub>SENSE</sub> = 10 KΩ		8		V
I <sub>SENSEH</sub> <sup>(1)</sup>	Analog sense output current in fault conditions	V <sub>CC</sub> = 13 V; V <sub>SENSE</sub> = 5 V		9		mA

Table 9. Current sense (8 V < V<sub>CC</sub> < 18 V) (continued)

Symbol	Parameter	Test conditions	Min	Typ	Max	Unit
t <sub>DSENSE1H</sub>	Delay response time from falling edge of DE pin	V <sub>SENSE</sub> < 4 V, 5 A < I <sub>out</sub> < 25 A I <sub>SENSE</sub> = 90 % of I <sub>SENSE max</sub> (see <a href="#">Figure 4</a> )		50	100	μs
t <sub>DSENSE1L</sub>	Delay response time from rising edge of DE pin	V <sub>SENSE</sub> < 4 V, 5 A < I <sub>out</sub> < 25 A I <sub>SENSE</sub> = 10 % of I <sub>SENSE max</sub> (see <a href="#">Figure 4</a> )		5	20	μs
t <sub>DSENSE2H</sub>	Delay response time from rising edge of INPUT pin	V <sub>SENSE</sub> < 4 V, 5 A < I <sub>out</sub> < 25 A I <sub>SENSE</sub> = 90 % of I <sub>SENSE max</sub> (see <a href="#">Figure 4</a> )		200	600	μs
Δt <sub>DSENSE2H</sub>	Delay response time between rising edge of output current and rising edge of current sense	V <sub>SENSE</sub> < 4 V, I <sub>SENSE</sub> = 90 % of I <sub>SENSEMAX</sub> , I <sub>OUT</sub> = 90 % of I <sub>OUTMAX</sub> I <sub>OUTMAX</sub> = 25 A (see <a href="#">Figure 7</a> )			200	μs
t <sub>DSENSE2L</sub>	Delay response time from falling edge of INPUT pin	V <sub>SENSE</sub> < 4 V, 5 A < I <sub>out</sub> < 25 A I <sub>SENSE</sub> = 10 % of I <sub>SENSE max</sub> (see <a href="#">Figure 4</a> )		100	250	μs

1. Parameter guaranteed by design; it is not tested.
2. Fault conditions include: power limitation, overtemperature and open load OFF state detection.

Table 10. Open-load detection (8 V < V<sub>CC</sub> < 18 V, V<sub>DE</sub> = 5 V)

Symbol	Parameter	Test conditions	Min.	Typ.	Max.	Unit
V <sub>OL</sub>	Open-load off state voltage detection threshold	V <sub>IN</sub> = 0 V; V <sub>DE</sub> = 5 V; See <a href="#">Figure 5</a>	2	—	4	V
t <sub>DSTKON</sub>	Output short circuit to V <sub>CC</sub> detection delay at turn off	V <sub>DE</sub> = 5 V; See <a href="#">Figure 5</a>	180	—	1200	μs
I <sub>L(off2)r</sub>	Off-state output current at V <sub>OUT</sub> = 4V	V <sub>IN</sub> = 0 V; V <sub>SENSE</sub> = 0 V V <sub>DE</sub> = 5 V; V <sub>OUT</sub> rising from 0V to 4 V	-120	—	90	μA
I <sub>L(off2)f</sub>	Off-state output current at V <sub>OUT</sub> = 2V	V <sub>IN</sub> = 0 V; V <sub>SENSE</sub> = V <sub>SENSEH</sub> V <sub>DE</sub> = 5 V; V <sub>OUT</sub> falling from V <sub>CC</sub> to 2 V	-50	—	90	μA
td_vol	Delay response from output rising edge to V <sub>SENSE</sub> rising edge in open load	V <sub>OUT</sub> = 4 V; V <sub>IN</sub> = 0 V V <sub>DE</sub> = 5 V; V <sub>SENSE</sub> = 90 % of V <sub>SENSEH</sub>		—	20	μs
td_voh	Delay response from output falling edge to V <sub>SENSE</sub> falling edge in open-load	V <sub>OUT</sub> = 2 V; V <sub>IN</sub> = 0 V V <sub>DE</sub> = 5 V; V <sub>SENSE</sub> = 10 % of V <sub>SENSEH</sub>		—	20	μs

Figure 4. Current sense delay characteristics

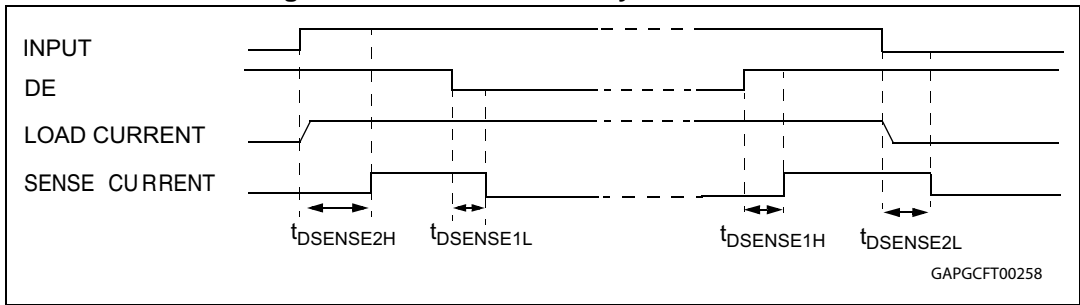

Figure 5. Open load Off-state delay timing

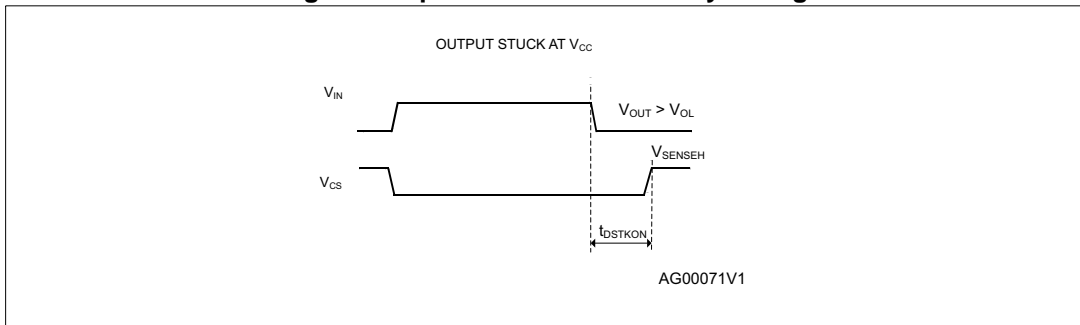

Figure 6. Switching characteristics

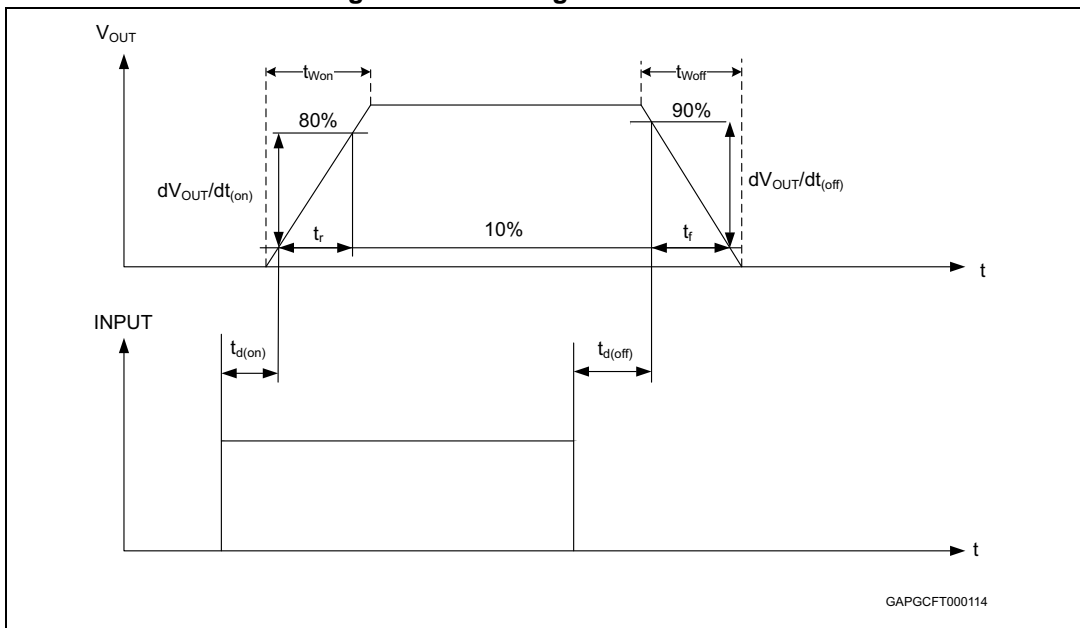

Figure 7. Delay response time between rising edge of output current and rising edge of current sense (CS enabled)

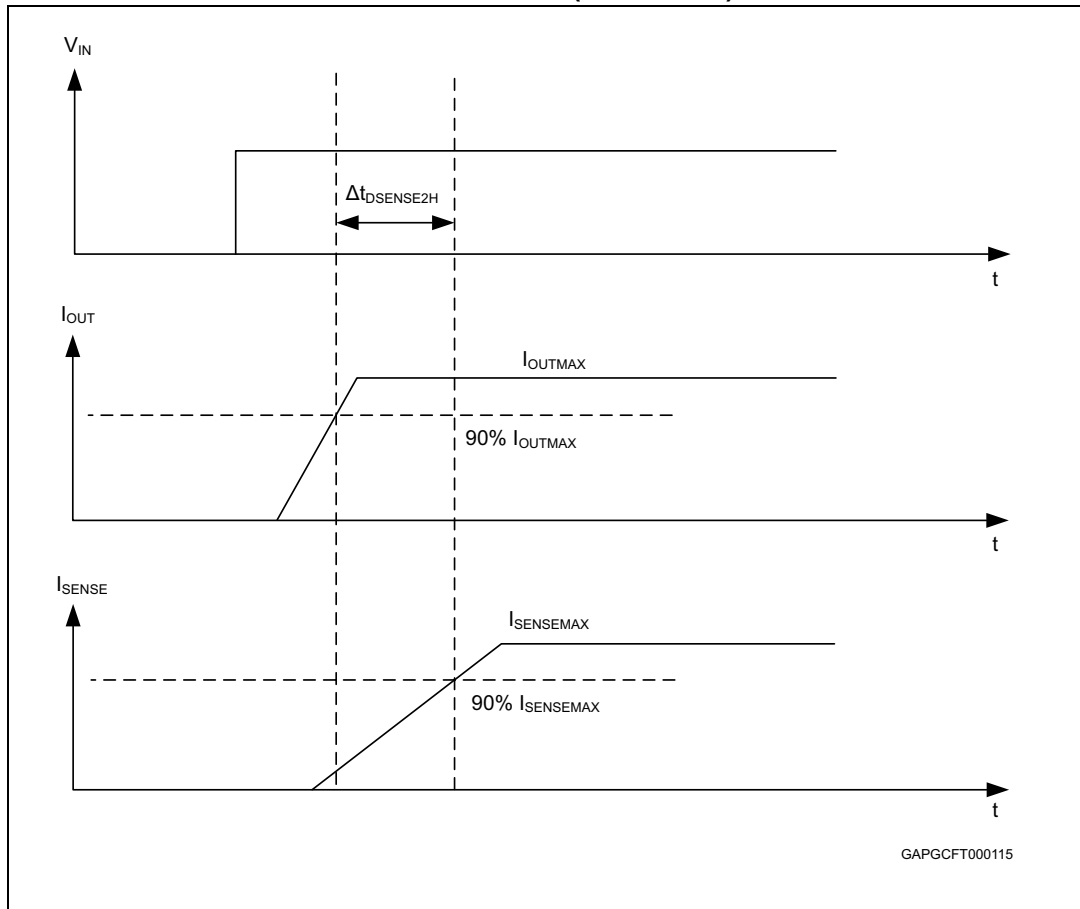

Figure 8. Output voltage drop limitation

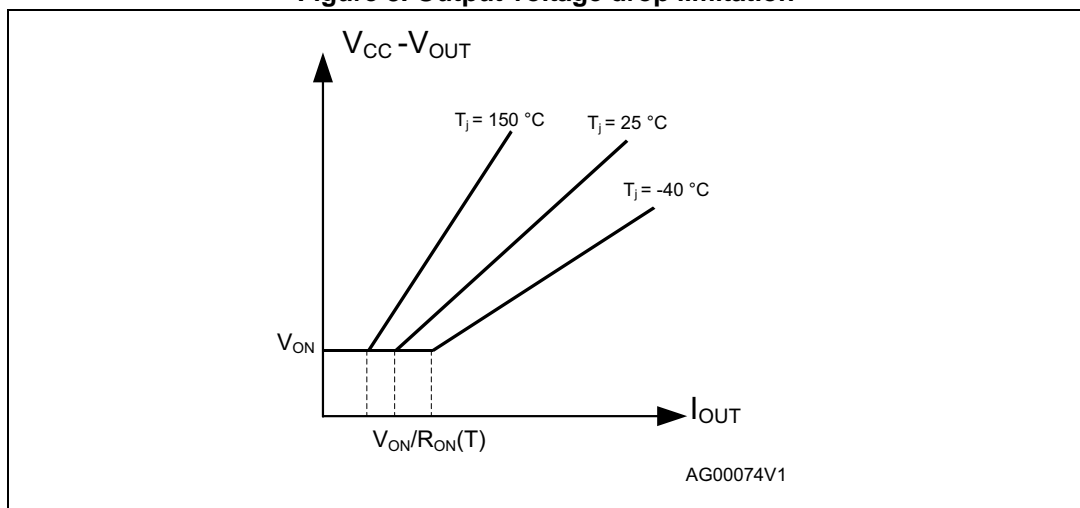

Figure 9.  $I_{OUT}/I_{SENSE}$  vs  $I_{OUT}$

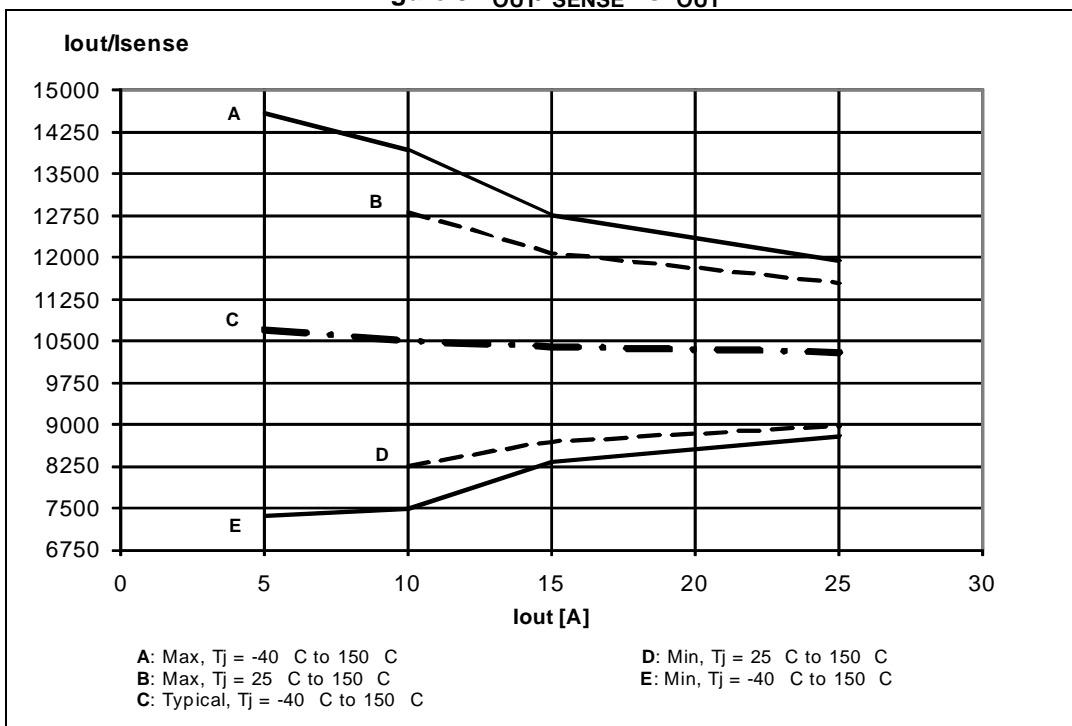

Figure 10. Maximum current sense ratio drift vs load current

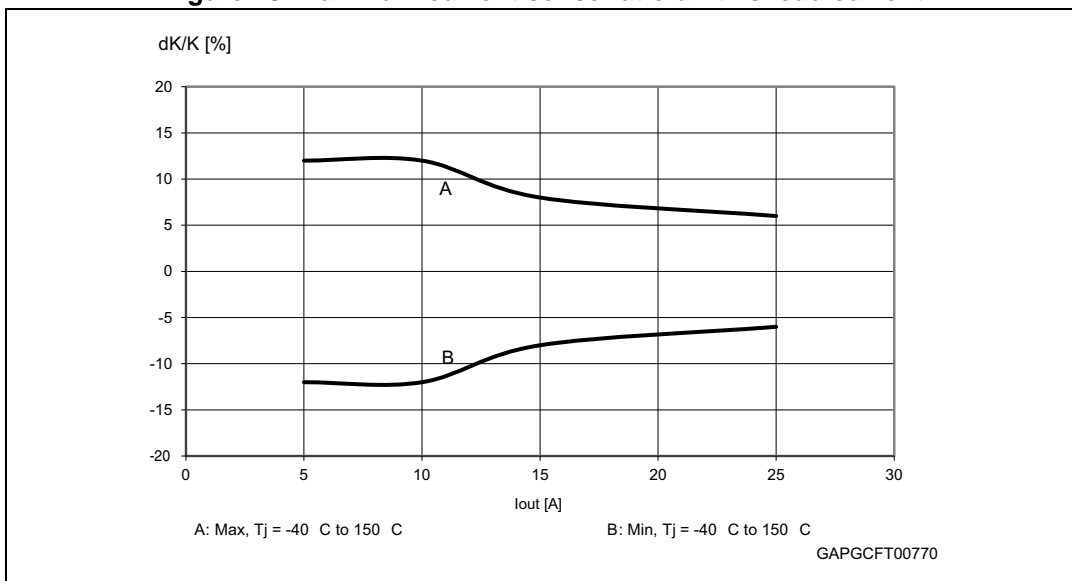

Table 11. Truth table

Conditions	Enable	Input	Output	Sense ( $V_{DE} = 5\text{ V}$ ) <sup>(1)</sup>
Normal operation	H	L	L	0
	H	H	H	Nominal
Overtemperature	H	L	L	0
	H	H	L	$V_{SENSEH}$
Undervoltage	H	L	L	0
	H	H	L	0
Overload	H	H	X (no power limitation)	Nominal
	H	H	Cycling (power limitation)	$V_{SENSEH}$
Short circuit to GND (Power limitation)	H	L	L	0
	H	H	L	$V_{SENSEH}$
Open load OFF State (with external pull up)	H	L	H	$V_{SENSEH}$
Short circuit to $V_{CC}$ (external pull up disconnected)	H	L	H	$V_{SENSEH}$
	H	H	H	< Nominal
Negative output voltage clamp	H	L	L	0

1. If the  $V_{DE}$  is low, the SENSE output is at a high impedance, its potential depends on leakage currents and external circuit.



Table 12. Electrical transient requirements (part 1)

ISO 7637-2: 2004(E) Test Pulse	Test levels <sup>(1)</sup>		Number of pulses or test times	Burst cycle/pulse repetition time		Delays and impedance
	III	IV				
1	-75 V	-100 V	5000 pulses	0.5 s	5 s	2 ms, 10 Ω
2a	+37 V	+50 V	5000 pulses	0.2 s	5 s	50 μs, 2 Ω
3a	-100 V	-150 V	1h	90 ms	100 ms	0.1 μs, 50 Ω
3b	+75 V	+100 V	1h	90 ms	100 ms	0.1 μs, 50 Ω
4	-6 V	-7 V	1 pulse			100 ms, 0.01 Ω
5b <sup>(2)</sup>	+65 V	+87 V	1 pulse			400 ms, 2 Ω

1. The above test levels must be considered referred to  $V_{CC} = 13.5V$  except for pulse 5b.
2. Valid in case of external load dump clamp: 40V maximum referred to ground. The protection strategy allows PowerMOS to be cyclically switched on during load dump, so distributing the load dump energy along the time and to transfer a part of it to the load.

Table 13. Electrical transient requirements (part 2)

ISO 7637-2: 2004(E) test pulse	Test level results <sup>(1)</sup>	
	III	IV
1	C	C
2a	C	C
3a	C	C
3b	C	C
4	C	C
5b (2) (3)	C	C

1. The above test levels must be considered referred to  $V_{CC} = 13.5V$  except for pulse 5b.
2. Valid in case of external load dump clamp: 40V maximum referred to ground. The protection strategy allows PowerMOS to be cyclically switched on during load dump, so distributing the load dump energy along the time and to transfer a part of it to the load.
3. Suppressed load dump (pulse 5b) is withstood with a minimum load connected as specified in [Table 3.:](#) *Absolute maximum ratings.*

Table 14. Electrical transient requirements (part 3)

Class	Contents
C	All functions of the device are performed as designed after exposure to disturbance.
E	One or more functions of the device are not performed as designed after exposure to disturbance and cannot be returned to proper operation without replacing the

## 2.4 Waveforms

Figure 11. Normal operation

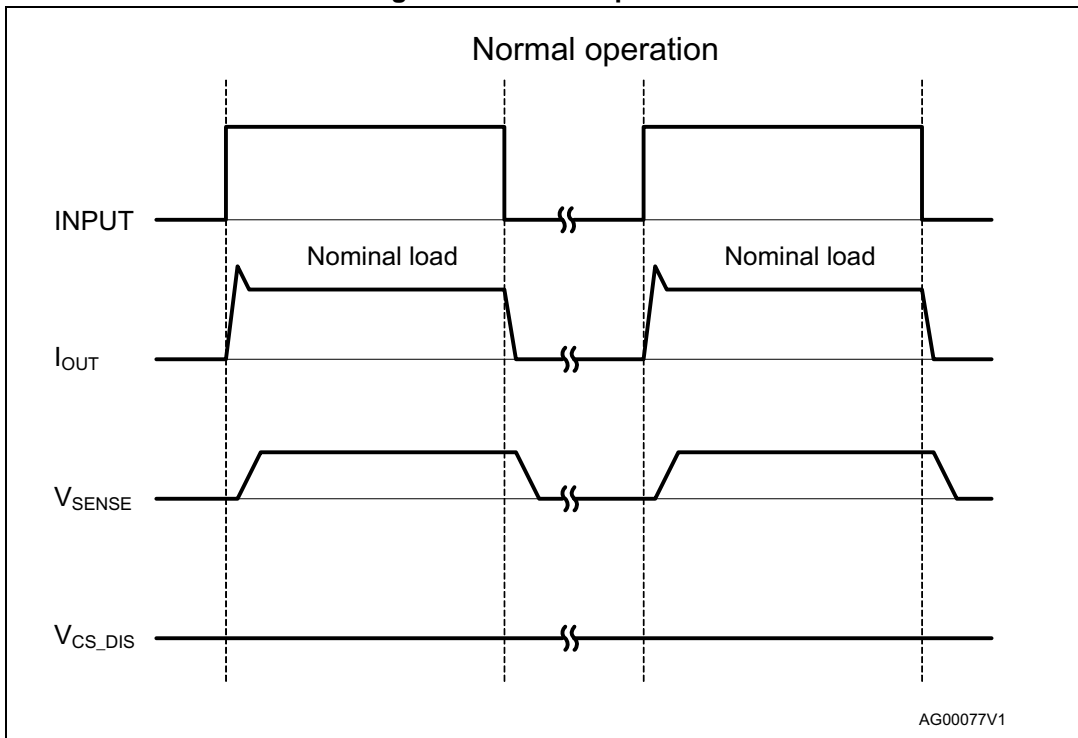

Figure 12. Overload or short to GND

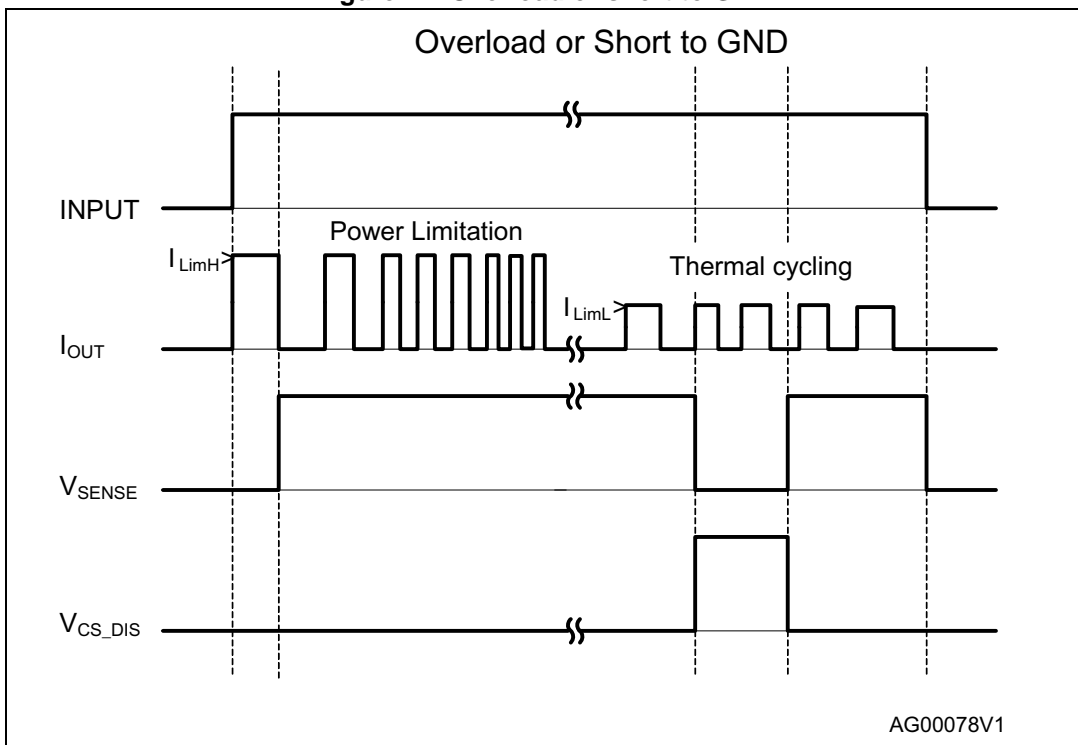
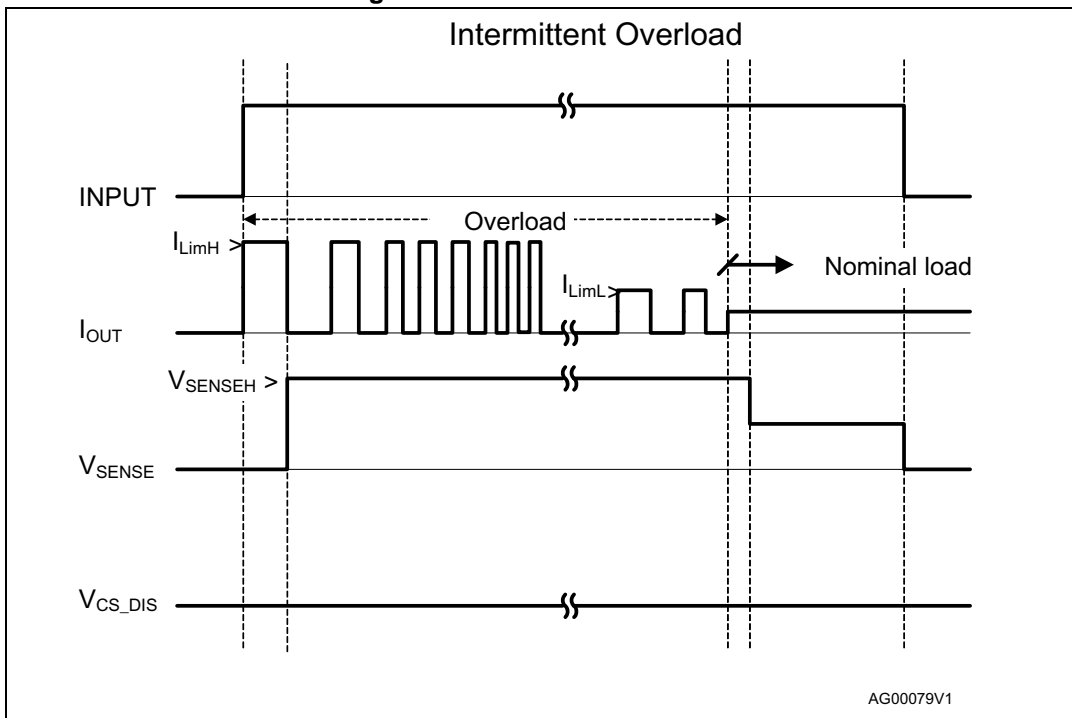
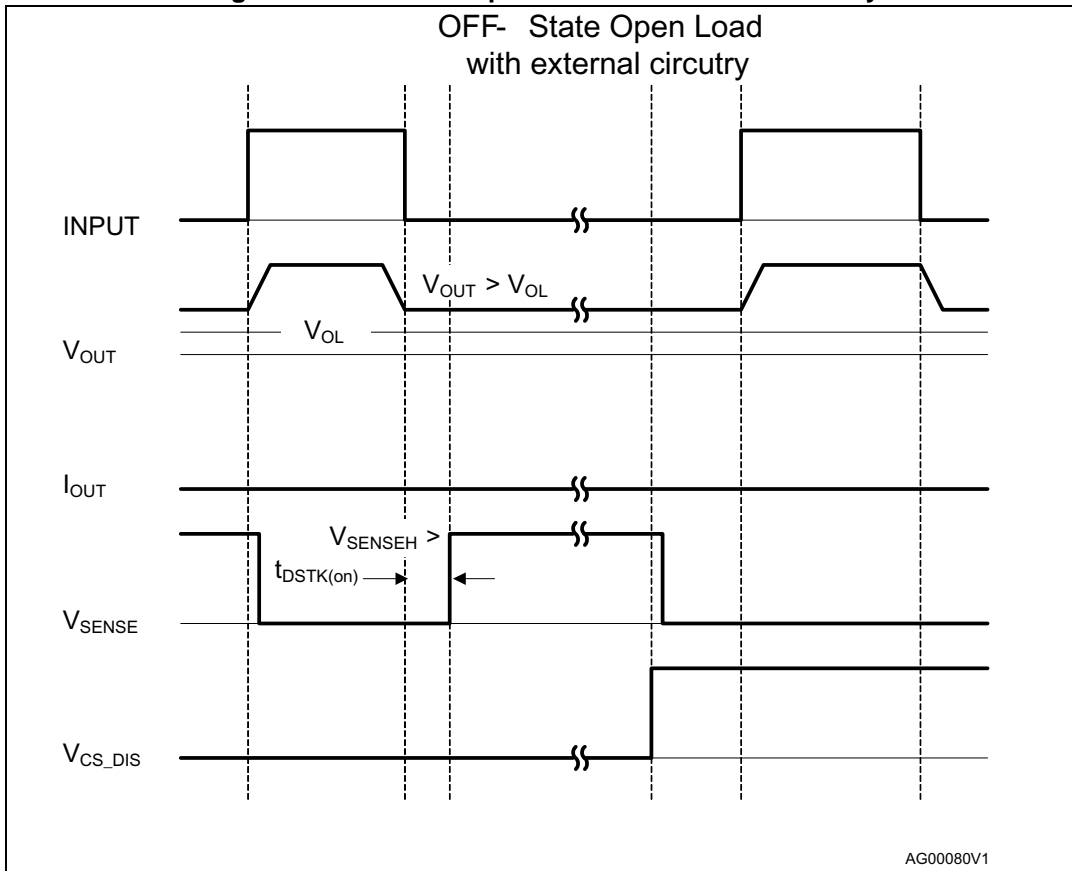

Figure 13. Intermittent overload



AG00079V1

Figure 14. OFF-state open load with external circuitry



AG00080V1

Figure 15. Short to V<sub>CC</sub>

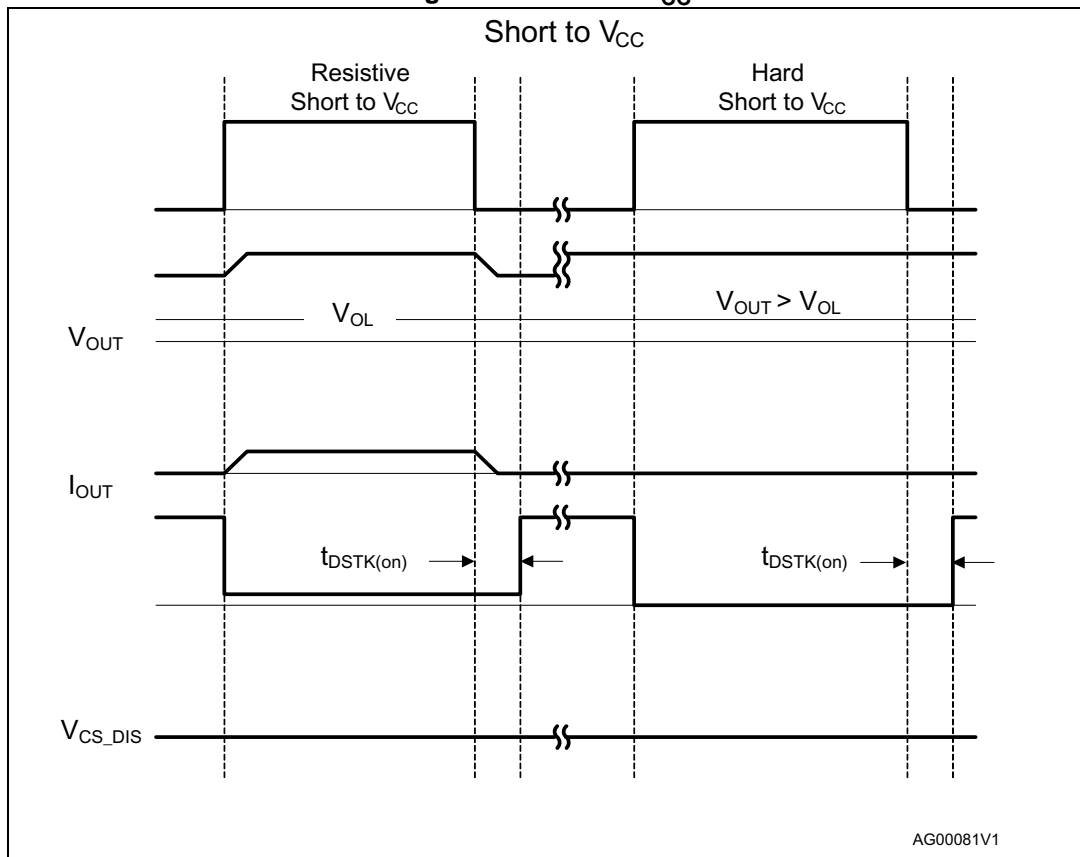
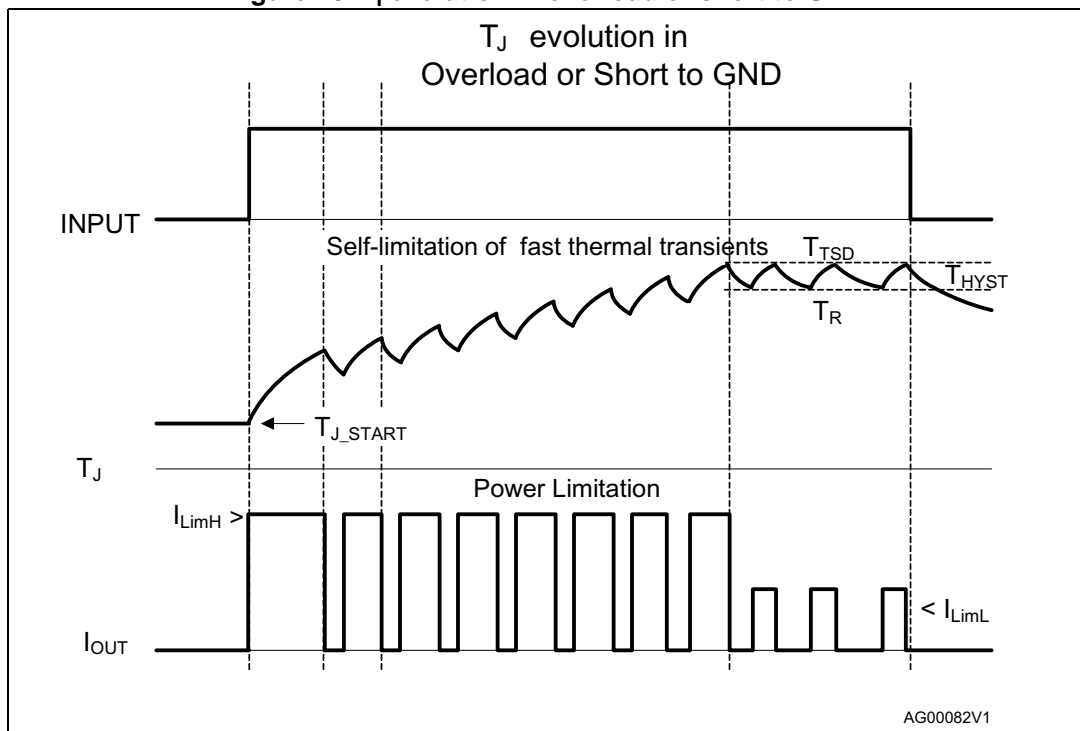
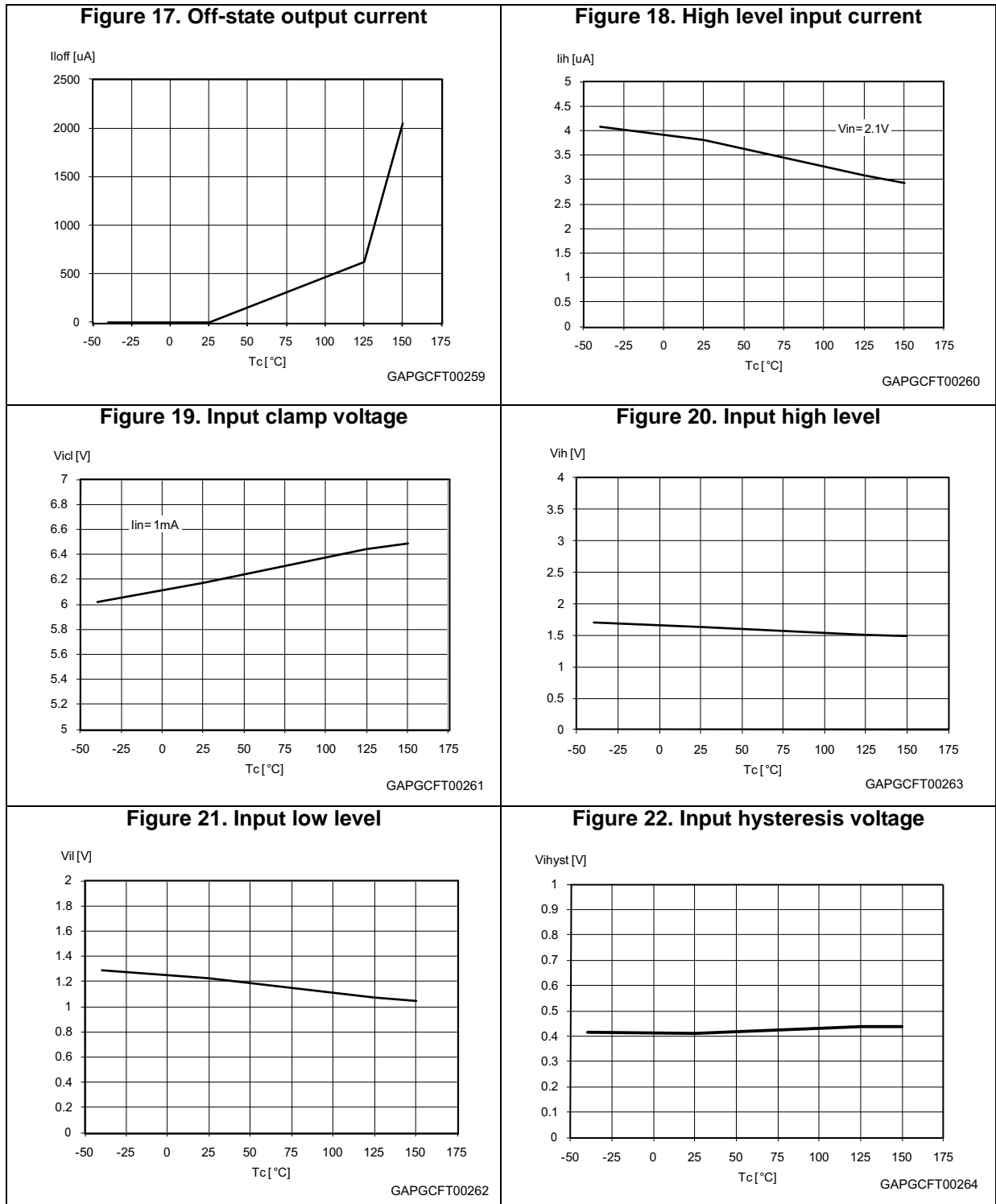

Figure 16. T<sub>i</sub> evolution in overload or short to GND



## 2.5 Electrical characteristics curves



**Figure 23. On-state resistance vs  $T_{case}$**

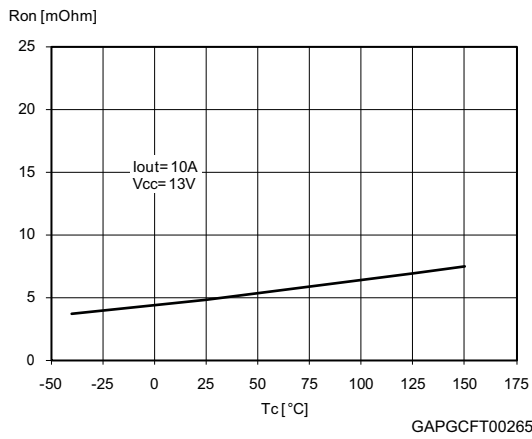

**Figure 24. On state resistance vs  $V_{CC}$**

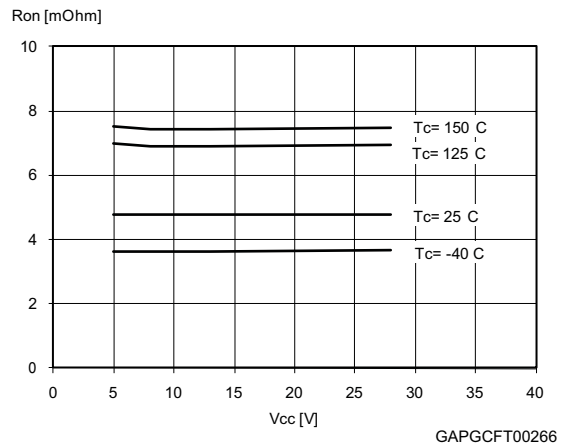

**Figure 25. Undervoltage shutdown**

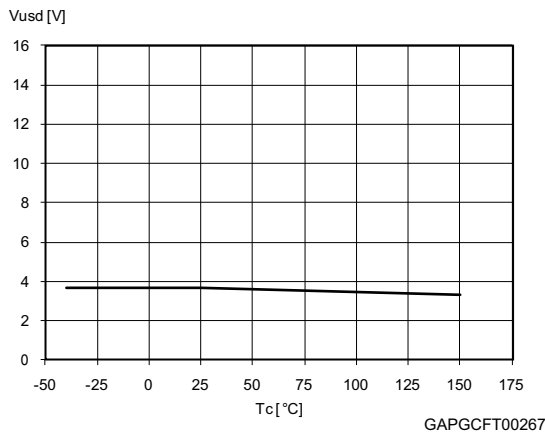

**Figure 26.  $I_{LIMH}$  vs  $T_{case}$**

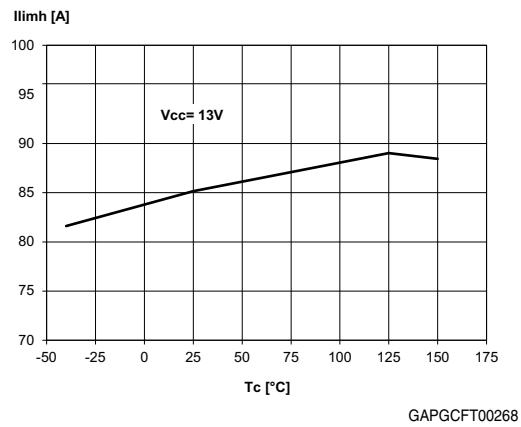

**Figure 27. Turn-on voltage slope**

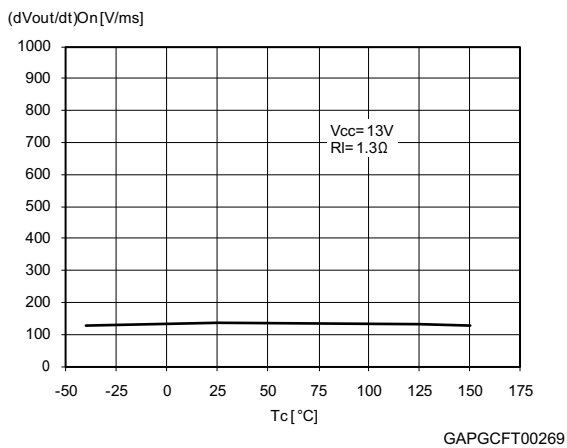

**Figure 28. Turn-off voltage slope**

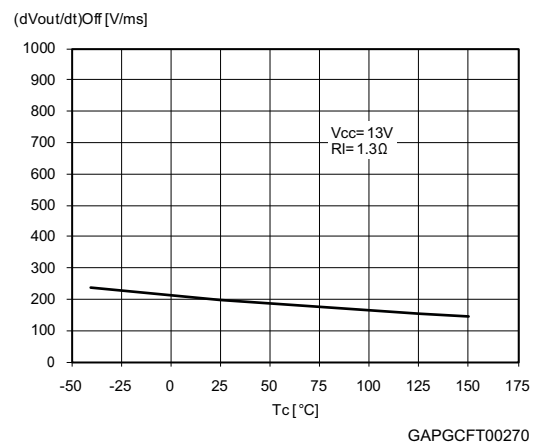

Figure 29. DE clamp voltage

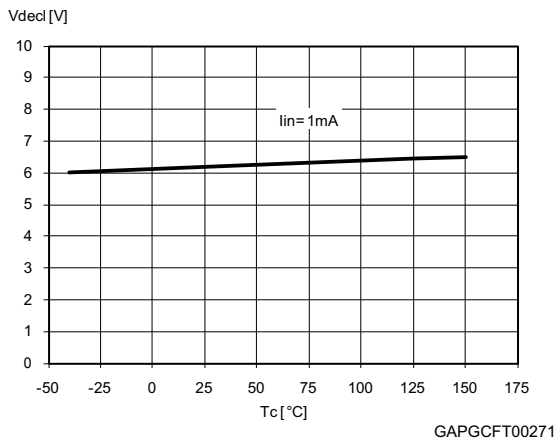

Figure 30. Low level DE voltage

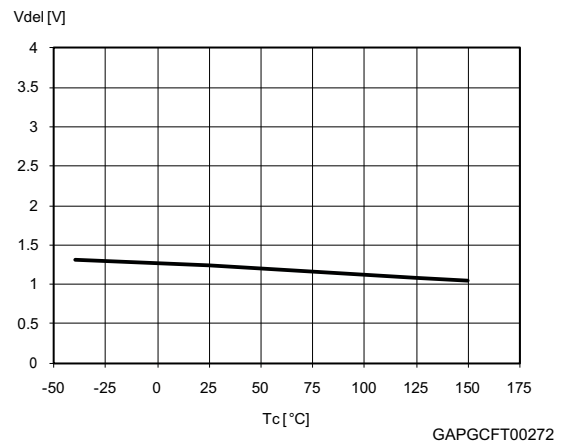
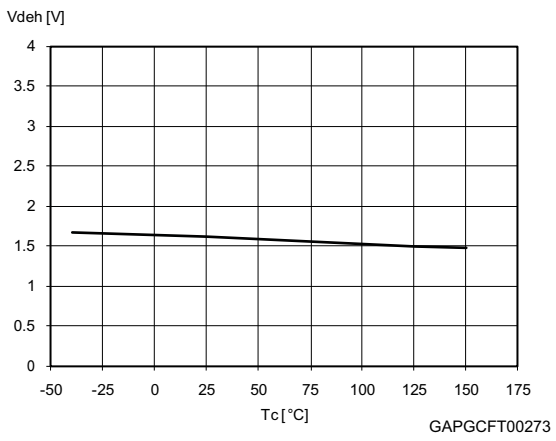
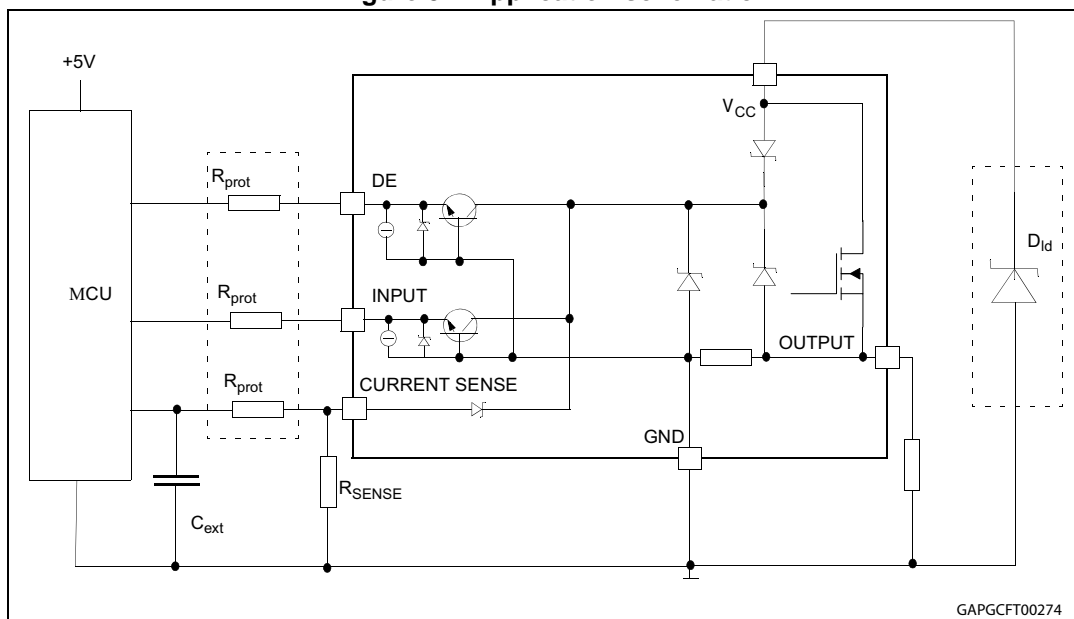

Figure 31. High level DE voltage



### 3 Application information

Figure 32. Application schematic



#### 3.1 MCU I/Os protection

When negative transients are present on the  $V_{CC}$  line, the control pins are pulled negative to approximately -1.5V.

ST suggests the insertion of resistors ( $R_{prot}$ ) in the lines to prevent the microcontroller I/O pins from latching up.

The values of these resistors provide a compromise between the leakage current of the microcontroller, the current required by the HSD I/Os (input levels compatibility) and the latch-up limit of the microcontroller I/Os.

$$-V_{CCpeak}/I_{latchup} \leq R_{prot} \leq (V_{OH\mu C} - V_{IH}) / I_{IHmax}$$

Calculation example:

For  $V_{CCpeak} = -1.5\text{ V}$  and  $I_{latchup} \geq 20\text{ mA}$ ;  $V_{OH\mu C} \geq 4.5\text{ V}$

$$75\ \Omega \leq R_{prot} \leq 240\text{ k}\Omega$$

Recommended values:  $R_{prot} = 10\text{ k}\Omega$ ,  $C_{EXT} = 10\text{ nF}$

#### 3.2 Load dump protection

$D_{ld}$  is necessary (voltage transient suppressor) if the load dump peak voltage exceeds the  $V_{CCPK\ max}$  rating. The same applies if the device is subject to transients on the  $V_{CC}$  line that are greater than the ones shown in the ISO 7637-2: 2004(E) table.





### 3.3.1 Short to $V_{CC}$ and off-state open-load detection

Short to  $V_{CC}$

A short circuit between  $V_{CC}$  and output is indicated by the relevant current sense pin set to  $V_{SENSEH}$  during the device off state. Small or no current is delivered by the current sense during the on state depending on the nature of the short circuit.

OFF-state open-load with external circuitry

Detection of an open-load in off mode requires an external pull-up resistor  $R_{PU}$  connecting the output to a positive supply voltage  $V_{PU}$ .

It is preferable  $V_{PU}$  to be switched off during the module standby mode in order to avoid the overall standby current consumption to increase in normal conditions, i.e. when load is connected.

An external pull down resistor  $R_{PD}$  connected between output and GND is mandatory to avoid misdetection in case of floating outputs in off-state (see [Figure 33: Current sense and diagnostics](#)).

$R_{PD}$  must be selected in order to ensure  $V_{OUT} < V_{OLmin}$  unless pulled up by the external circuitry:

$$V_{OUT}|_{Pull-up\_OFF} = R_{PD} \cdot I_{L(off2)f} < V_{OLmin} = 2V$$

$R_{PD} \leq 22 \text{ K}\Omega$  is recommended.

For proper open load detection in off state, the external pull-up resistor must be selected according to the following formula:

$$V_{OUT}|_{Pull-up\_ON} = \frac{R_{PD} \cdot V_{PU} - R_{PU} \cdot R_{PD} \cdot I_{L(off2)r}}{R_{PU} + R_{PD}} > V_{OLmax} = 4V$$

For the values of  $V_{OLmin}$ ,  $V_{OLmax}$ ,  $I_{L(off2)r}$  and  $I_{L(off2)f}$  see [Table 10: Open-load detection](#) ( $8 \text{ V} < V_{CC} < 18 \text{ V}$ ,  $V_{DE} = 5 \text{ V}$ ).

### 3.4 Maximum demagnetization energy ( $V_{CC} = 13.5\text{ V}$ )

Figure 34. Maximum turn-off current versus inductance

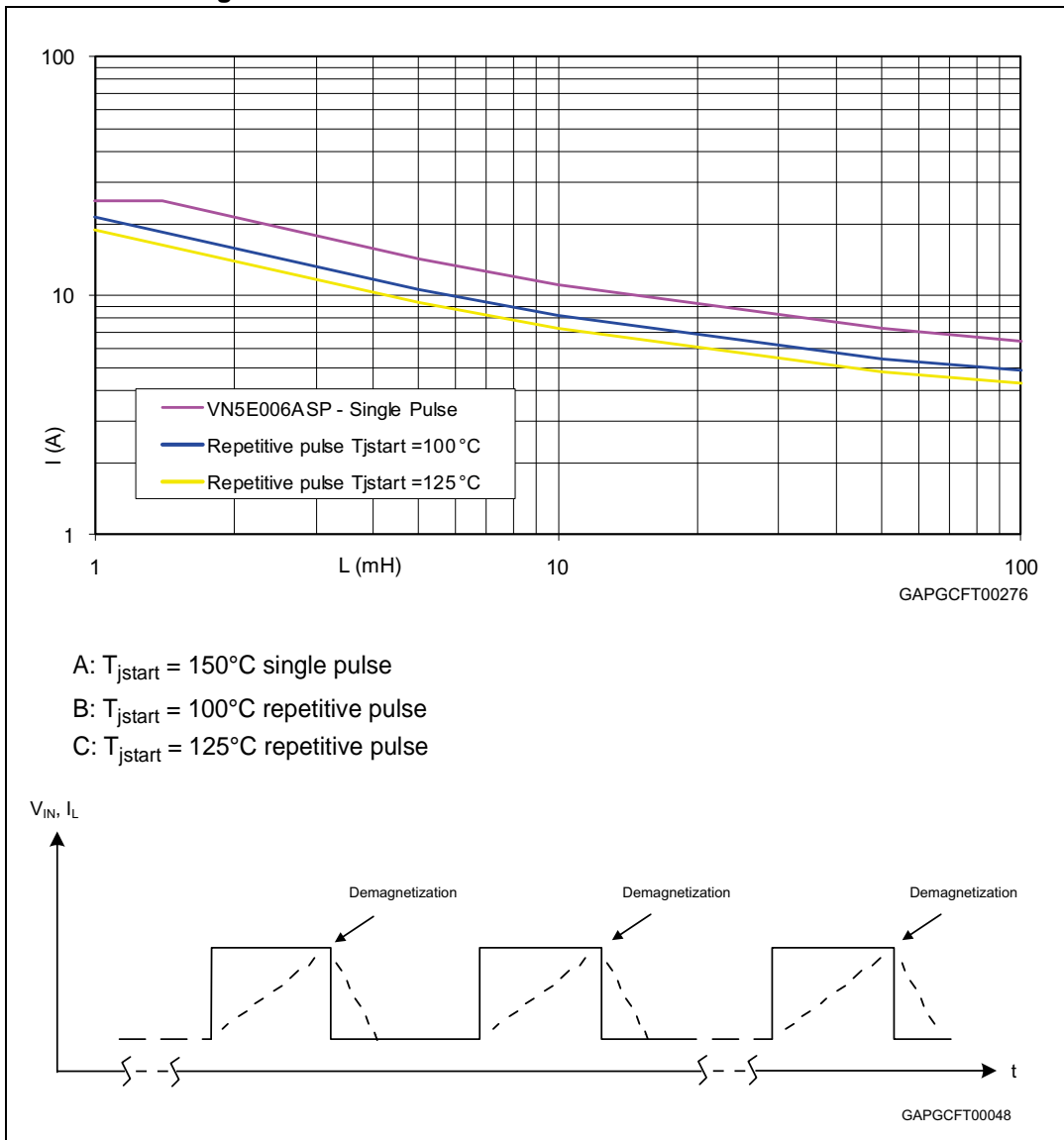

- A:  $T_{jstart} = 150^\circ\text{C}$  single pulse
- B:  $T_{jstart} = 100^\circ\text{C}$  repetitive pulse
- C:  $T_{jstart} = 125^\circ\text{C}$  repetitive pulse

Note: Values are generated with  $R_L = 0\ \Omega$ .  
 In case of repetitive pulses,  $T_{jstart}$  (at beginning of each demagnetization) of every pulse must not exceed the temperature specified above for curves A and B.

## 4 Package and PCB thermal data

### 4.1 PowerSO-10 thermal data

Figure 35. PowerSO-10 PC board

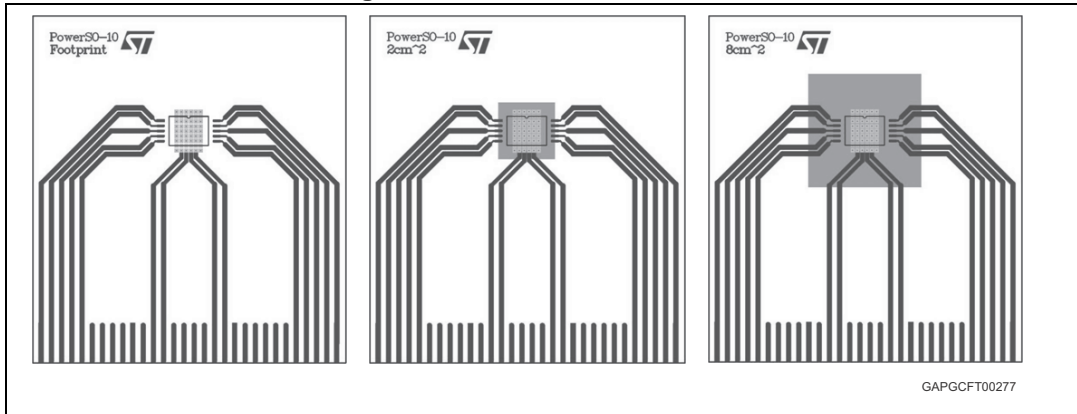

1. Layout condition of  $R_{th}$  and  $Z_{th}$  measurements (Board finish thickness 1.6 mm +/- 10%; Board double layer; Board dimension 77x86; Board Material FR4; Cu thickness 0.070mm (front and back side); Thermal vias separation 1.2 mm; Thermal via diameter 0.3 mm +/- 0.08 mm; Cu thickness on vias 0.025 mm).

Figure 36.  $R_{thj-amb}$  vs PCB copper area in open box free air condition (one channel on)

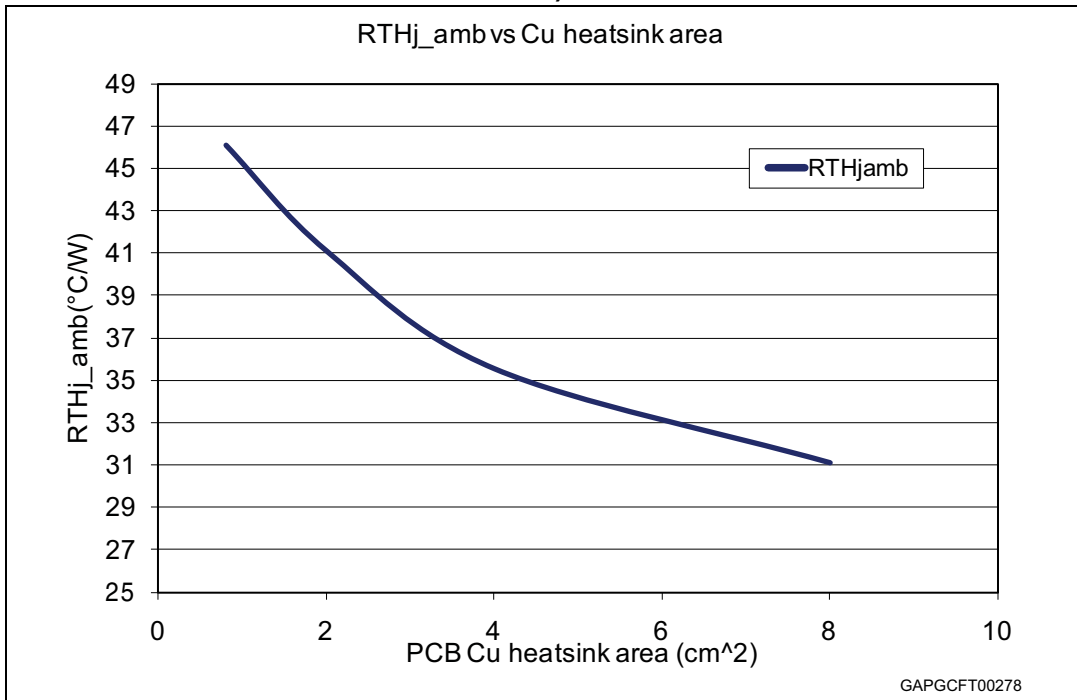

**Figure 37. PowerSO-10 thermal impedance junction ambient single pulse (one channel on)**

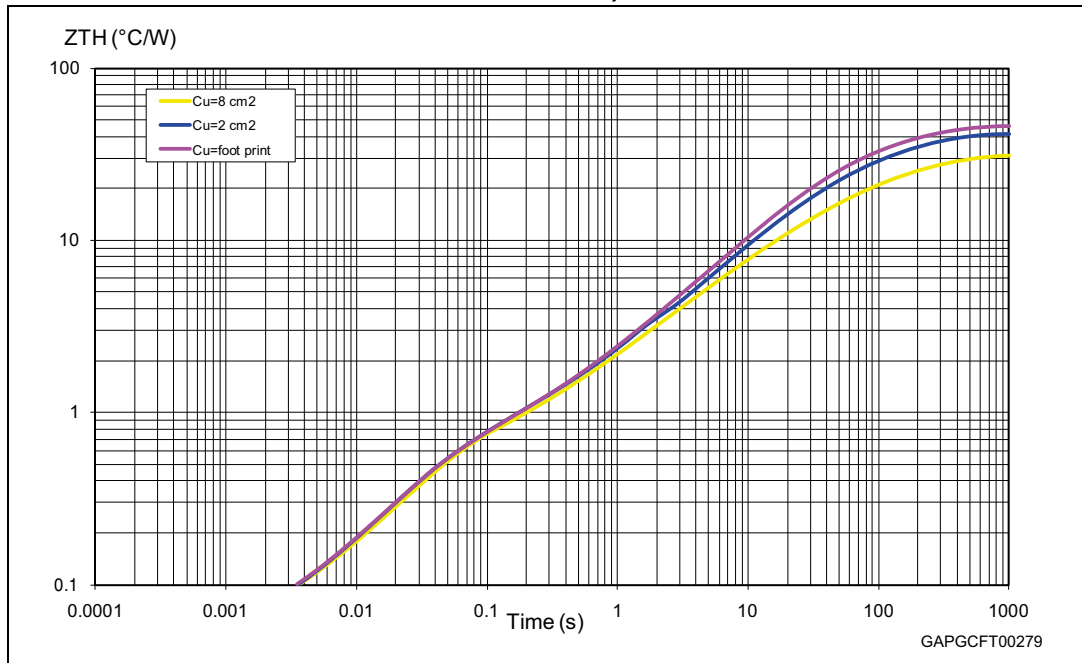

**Figure 38. Thermal fitting model of a single channel HSD in PowerSO-10**

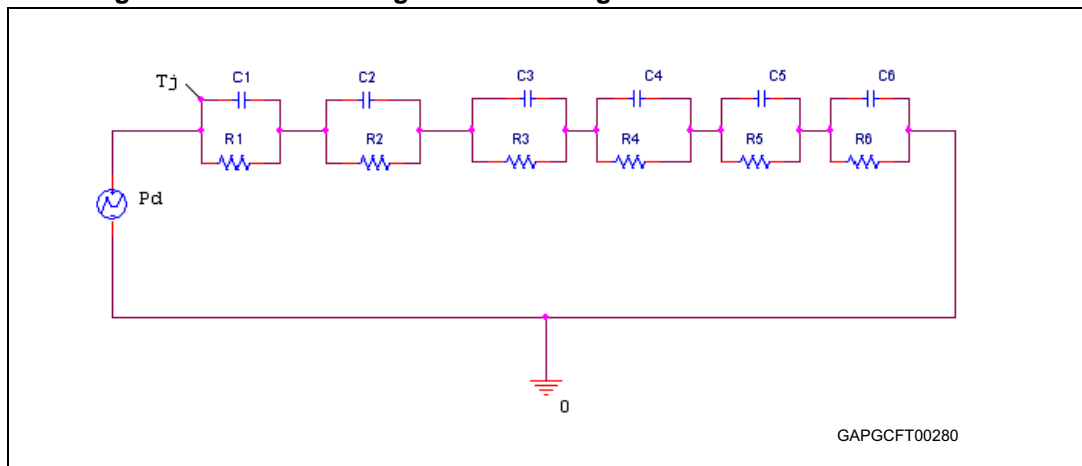

1. The fitting model is a simplified thermal tool and is valid for transient evolutions where the embedded protections (power limitation or thermal cycling during thermal shutdown) are not triggered.

**Equation 1: pulse calculation formula**

$$Z_{TH\delta} = R_{TH} \cdot \delta + Z_{THtp}(1 - \delta)$$

where  $\delta = t_p/T$

Table 15. Thermal parameter

Area/island (cm <sup>2</sup> )	Footprint	2	8
R1 (°C/W)	0.05		
R2 (°C/W)	0.6		
R3 (°C/W)	1.5		
R4 (°C/W)	7		
R5 (°C/W)	13	12	8
R6 (°C/W)	24	20	14
C1 (W.s/°C)	0.1		
C2 (W.s/°C)	0.08		
C3 (W.s/°C)	0.8		
C4 (W.s/°C)	2		
C5 (W.s/°C)	3	4	8
C6 (W.s/°C)	6	8	14

## 5 Package information

### 5.1 ECOPACK<sup>®</sup> packages

In order to meet environmental requirements, ST offers these devices in different grades of ECOPACK<sup>®</sup> packages, depending on their level of environmental compliance. ECOPACK<sup>®</sup> specifications, grade definitions and product status are available at: [www.st.com](http://www.st.com). ECOPACK<sup>®</sup> is an ST trademark.

## 5.2 PowerSO-10 mechanical data

Figure 39. PowerSO-10 package dimensions

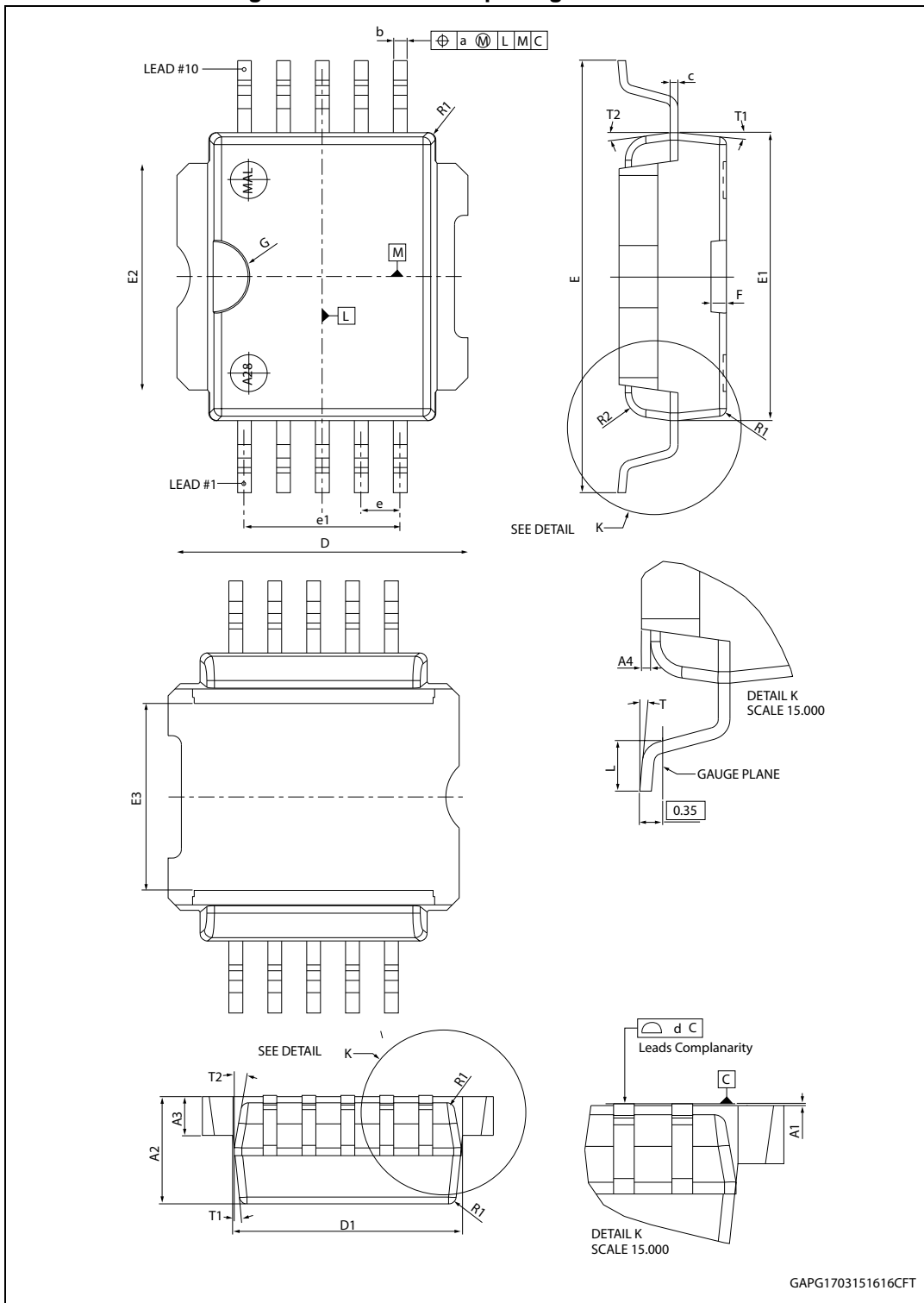



Table 16. PowerSO-10 mechanical data

Symbol	Millimeters		
	Min.	Typ.	Max.
A1	0	0.05	0.10
A2	3.40	3.50	3.60
A3	1.20	1.30	1.40
A4	0.15	0.20	0.25
a		0.20	
b	0.37	0.45	0.53
c	0.23	0.27	0.32
D	9.40	9.50	9.60
D1	7.40	7.50	7.60
d	0	0.05	0.10
E	13.85	14.10	14.35
E1 <sup>(1)</sup>	9.30	9.40	9.50
E2	7.30	7.40	7.50
E3	5.90	6.10	6.30
e		1.27	
e1		5.08	
F		0.50	
G		1.20	
L	0.80	1.00	1.10
R1			0.25
R2		0.80	
T	2°	5°	8°
T1		6°	
T2		10°	

1. Resin protrusions not included (max value: 0.15 mm per side).

### 5.3 Packing information

Figure 40. PowerSO-10 suggested pad layout and tube shipment (no suffix)

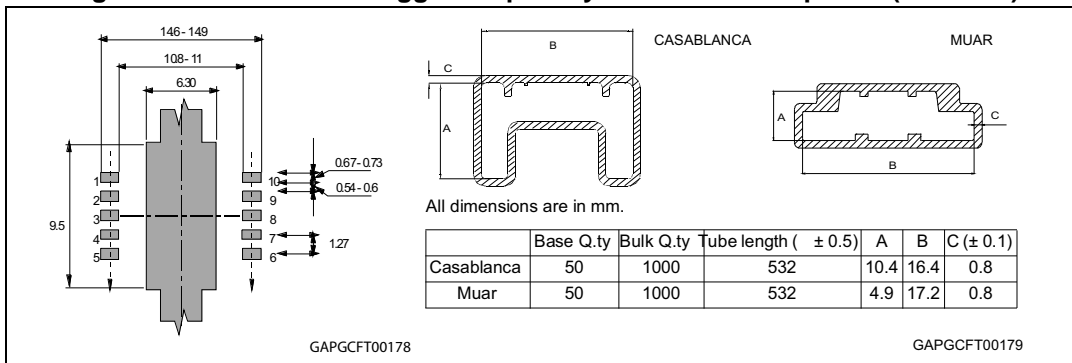
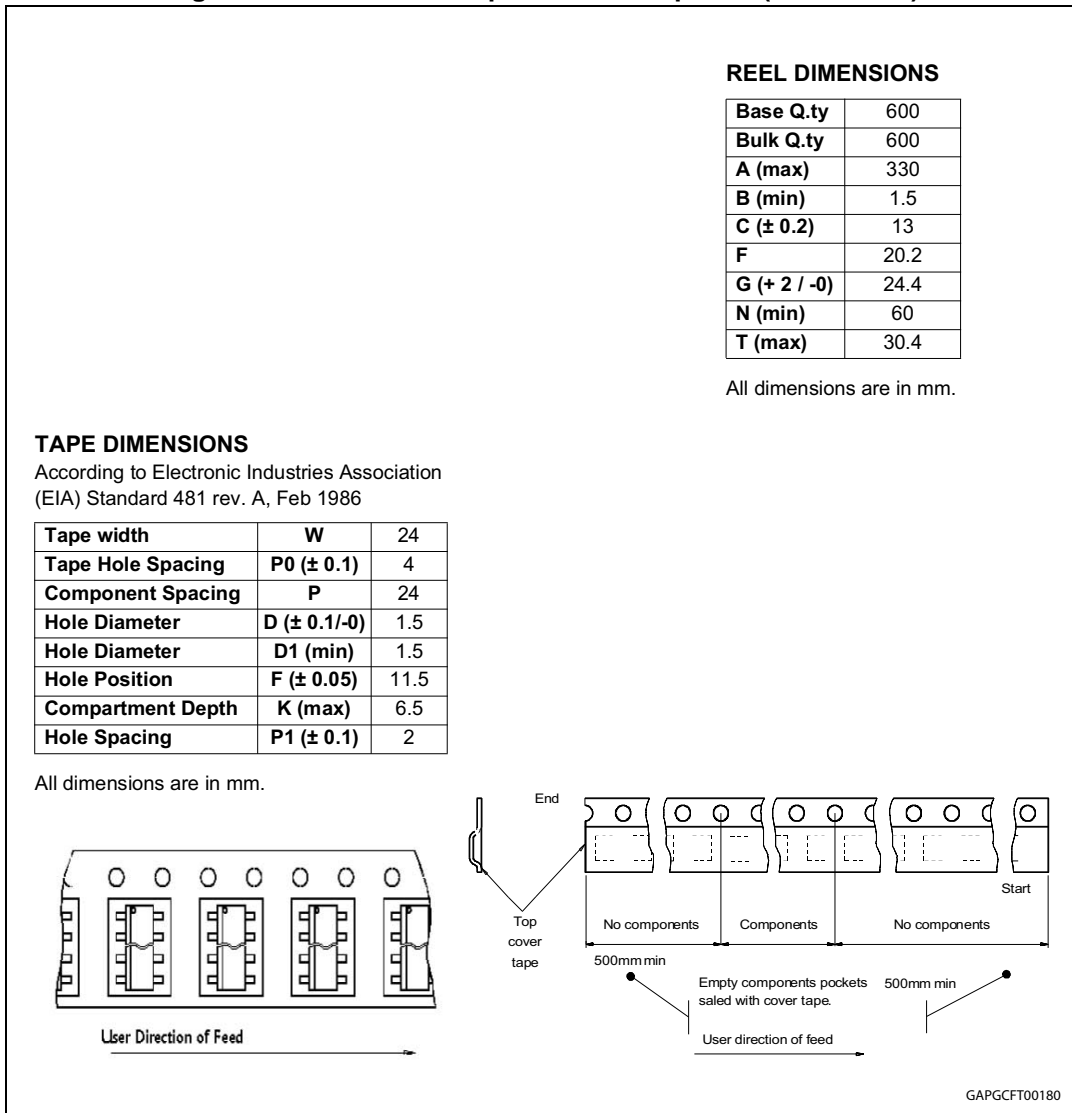

Figure 41. PowerSO-10 tape and reel shipment (suffix “TR”)



## 6 Order codes

Table 17. Device summary

Package	Order codes	
	Tube	Tape and reel
PowerSO-10	VN5E006ASP-E	VN5E006ASPTR-E

## 7 Revision history

**Table 18. Document revision history**

Date	Revision	Changes
01-Sep-2010	1	Internal release.
13-Sep-2010	2	<p>Updated document with diagnostic enable pin insertion.  <a href="#">Figure 2: Configuration diagram (top view)</a>            – changed pinout            Changed <a href="#">Figure 4: Current sense delay characteristics</a>  <a href="#">Table 3: Absolute maximum ratings</a>  <math>E_{MAX}</math>: updated parameters and value  <a href="#">Table 4: Thermal data</a>            – <math>R_{thj-case}</math>: updated maximum value  <a href="#">Table 5: Power section</a>            – <math>R_{ON}</math>: updated typical and maximum values            – <math>I_S</math>: replaced <math>V_{CE} = 0\text{ V}</math> with <math>V_{DE} = 0\text{ V}</math> for test conditions, changed typ/max value (first row), replaced <math>V_{CE} = 5\text{ V}</math> with <math>V_{DE} = 5\text{ V}</math> for test conditions, changed typ/max value (second and third row)  <a href="#">Table 6: Switching (<math>V_{CC} = 13\text{ V}</math>; <math>T_j = 25\text{ }^\circ\text{C}</math>)</a>            – <math>t_{d(on)}</math>, <math>t_{d(off)}</math>, <math>W_{ON}</math>, <math>W_{OFF}</math>: updated typical value  <a href="#">Table 9: Current sense (<math>8\text{ V} &lt; V_{CC} &lt; 18\text{ V}</math>)</a>            – <math>I_{OL}</math>: added new row            – <math>K_1, dK_1/K_1</math>: changed <math>V_{SENSE}</math> value (from 0.5 V to 4 V) for test conditions            – <math>K_0, K_1, K_2, K_3</math>: added <math>V_{DE} = 5\text{ V}</math> for test conditions            – <math>dK_0/K_0, dK_1/K_1, dK_2/K_2, dK_3/K_3</math>: replaced <math>V_{CSD} = 0\text{ V}</math> with <math>V_{DE} = 5\text{ V}</math> for test conditions            – <math>K_0, K_1, K_2, K_3</math>: updated minimum, typical and maximum values            – <math>dK_0/K_0, dK_1/K_1, dK_2/K_2, dK_3/K_3</math>: updated minimum and maximum values            – <math>I_{SENSE0}</math>: replaced <math>V_{CSD} = 5\text{ V}</math> with <math>V_{DE} = 0\text{ V}</math> (first row), replaced <math>V_{CSD} = 0\text{ V}</math> with <math>V_{DE} = 5\text{ V}</math>, added <math>I_{OUT} = 0\text{ A}</math>, added <math>V_{SENSE} = 0\text{ V}</math> (second row), replaced <math>V_{CSD} = 5\text{ V}</math> with <math>V_{DE} = 0\text{ V}</math> (third row) for test conditions            – <math>V_{SENSE}</math>: replaced <math>V_{CSD} = 0\text{ V}</math> with <math>V_{DE} = 5\text{ V}</math>, added <math>R_{SENSE}</math> for test conditions            – <math>t_{DSENSE1H}</math>, <math>t_{DSENSE1L}</math>, <math>t_{DSENSE2H}</math>, <math>t_{DSENSE2L}</math>: changed typ/max values            – <math>\Delta t_{DSENSE2H}</math>: changed maximum value  <a href="#">Table 10: Open-load detection (<math>8\text{ V} &lt; V_{CC} &lt; 18\text{ V}</math>, <math>V_{DE} = 5\text{ V}</math>)</a>            – <math>V_{OL}</math>: updated typical value            – <math>t_{d\_voh}</math>: updated maximum value            Updated <a href="#">Figure 9: <math>I_{OUT}/I_{SENSE}</math> vs <math>I_{OUT}</math></a>            Updated <a href="#">Figure 10: Maximum current sense ratio drift vs load current</a></p>

Table 18. Document revision history (continued)

Date	Revision	Changes
13-Sep-2010	2	<p>Changed <a href="#">Figure 11: Normal operation</a></p> <p>Changed <a href="#">Figure 12: Overload or short to GND</a></p> <p>Changed <a href="#">Figure 13: Intermittent overload</a></p> <p>Changed <a href="#">Figure 14: OFF-state open load with external circuitry</a></p> <p>Changed <a href="#">Figure 15: Short to V<sub>CC</sub></a></p> <p>Updated <a href="#">Chapter 4: Package and PCB thermal data</a></p> <p>Updated <a href="#">Chapter 5.1: ECOPACK® packages</a></p>
29-Sep-2010	3	<p><a href="#">Table 3: Absolute maximum ratings:</a></p> <ul style="list-style-type: none"> <li>– I<sub>OUT</sub>: updated value</li> <li>– V<sub>CCPK</sub>: updated parameter</li> </ul> <p><a href="#">Table 9: Current sense (8 V &lt; V<sub>CC</sub> &lt; 18 V):</a></p> <ul style="list-style-type: none"> <li>– K<sub>0</sub>, K<sub>1</sub>, K<sub>2</sub>, K<sub>3</sub>: updated minimum, typical and maximum values</li> <li>– Δt<sub>DSENSE2H</sub>: updated test condition</li> </ul> <p>Updated <a href="#">Figure 9: I<sub>OUT</sub>/I<sub>SENSE</sub> vs I<sub>OUT</sub></a></p>
20-Dec-2010	4	<p>Added <a href="#">Section 3.4: Maximum demagnetization energy (V<sub>CC</sub> = 13.5 V)</a></p> <p><a href="#">Table 3: Absolute maximum ratings:</a></p> <ul style="list-style-type: none"> <li>– E<sub>MAX</sub>: updated value</li> </ul> <p><a href="#">Table 8: Protections and diagnostic</a></p> <ul style="list-style-type: none"> <li>– I<sub>limH</sub>: updated minimum, typical and maximum values</li> </ul> <p><a href="#">Table 9: Current sense (8 V &lt; V<sub>CC</sub> &lt; 18 V)</a></p> <ul style="list-style-type: none"> <li>– K<sub>0</sub>, K<sub>1</sub>, K<sub>2</sub>, K<sub>3</sub>: updated minimum, typical and maximum values</li> </ul> <p>Updated <a href="#">Figure 9: I<sub>OUT</sub>/I<sub>SENSE</sub> vs I<sub>OUT</sub></a></p>
20-Apr-2011	5	Updated <a href="#">Table 17: Device summary</a>
18-May-2012	6	Updated <a href="#">Figure 26: I<sub>LIMH</sub> vs T<sub>case</sub></a>
19-Sep-2013	7	Updated Disclaimer.
25-Oct-2013	8	Updated footnote 2 into the <a href="#">Table 12: Electrical transient requirements (part 1)</a> and <a href="#">Table 13: Electrical transient requirements (part 2)</a> .
18-Mar-2015	9	Updated <a href="#">Section 5.2: PowerSO-10 mechanical data</a>

**IMPORTANT NOTICE – PLEASE READ CAREFULLY**

STMicroelectronics NV and its subsidiaries ("ST") reserve the right to make changes, corrections, enhancements, modifications, and improvements to ST products and/or to this document at any time without notice. Purchasers should obtain the latest relevant information on ST products before placing orders. ST products are sold pursuant to ST's terms and conditions of sale in place at the time of order acknowledgement.

Purchasers are solely responsible for the choice, selection, and use of ST products and ST assumes no liability for application assistance or the design of Purchasers' products.

No license, express or implied, to any intellectual property right is granted by ST herein.

Resale of ST products with provisions different from the information set forth herein shall void any warranty granted by ST for such product.

ST and the ST logo are trademarks of ST. All other product or service names are the property of their respective owners.

Information in this document supersedes and replaces information previously supplied in any prior versions of this document.

© 2015 STMicroelectronics – All rights reserved

## X-ON Electronics

Largest Supplier of Electrical and Electronic Components

*Click to view similar products for* [Power Switch ICs - Power Distribution](#) *category:*

*Click to view products by* [STMicroelectronics](#) *manufacturer:*

Other Similar products are found below :

[TCK111G,LF\(S\)](#) [FPF1018](#) [DS1222](#) [TCK2065G,LF](#) [SZNCP3712ASNT3G](#) [MIC2033-05BYMT-T5](#) [MIC2033-12AYMT-T5](#) [MIC2033-05BYM6-T5](#) [SLG5NT1437VTR](#) [SZNCP3712ASNT1G](#) [DML1008LDS-7](#) [KTS1670EDA-TR](#) [KTS1640QGDV-TR](#) [KTS1641QGDV-TR](#) [NCV459MNWTBG](#) [FPF2260ATMX](#) [U6513A](#) [U6119S](#) [MIC2012YM-TR](#) [MAX14919ATP+](#) [MC33882PEP](#) [TPS2021IDRQ1](#) [TPS2104DBVR](#) [MIC2098-1YMT-TR](#) [MIC94062YMT TR](#) [MP6231DN-LF](#) [MIC2075-2YM](#) [MIC2095-2YMT-TR](#) [MIC94068YML-TR](#) [SIP32461DB-T2-GE1](#) [NCP335FCT2G](#) [TCK105G,LF\(S\)](#) [AP2151DSG-13](#) [MIC94094YC6-TR](#) [MIC94064YC6-TR](#) [MIC2505-1YM](#) [MIC94305YMT-TR](#) [MIC94081YFT-TR](#) [MIC94042YFL-TR](#) [MIC94041YFL-TR](#) [MIC2005-1.2YM6-TR](#) [TPS2032QDRQ1](#) [SIP32510DT-T1-GE3](#) [NCP333FCT2G](#) [NCP331SNT1G](#) [TPS2092DR](#) [TPS2063DR](#) [TPS2042P](#) [MIC2008YML-TR](#) [MIC2040-1YMM](#)