



VND7N04, VND7N04-1 VNK7N04FM

"OMNIFET":
Fully autoprotected power MOSFET

Features

Type	V _{clamp}	R _{DS(on)}	I _{lim}
VND7N04	42 V	0.14 Ω	7 A
VND7N04-1	42 V	0.14 Ω	7 A
VNK7N04FM	42 V	0.14 Ω	7 A

- Linear current limitation
- Thermal shut down
- Short circuit protection
- Integrated clamp
- Low current drawn from input pin
- Diagnostic feedback through input pin
- ESD protection
- Direct access to the gate of the power MOSFET (analog driving)
- Compatible with standard power MOSFET

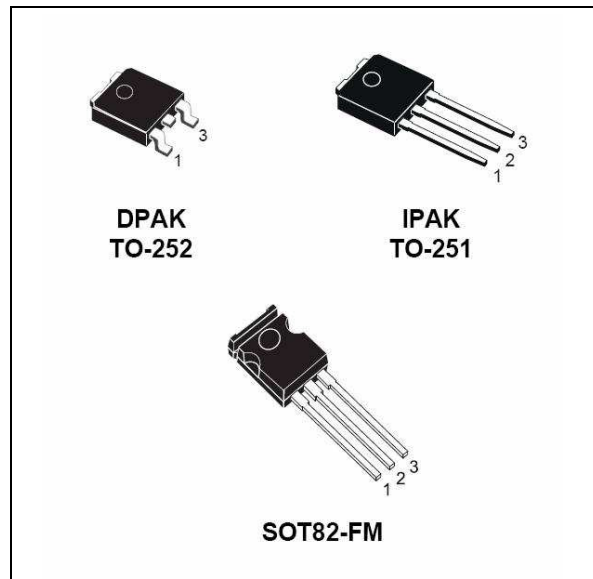

Description

The VND7N04, VND7N04-1 and VNK7N04FM are monolithic devices made using STMicroelectronics VIPower M0 Technology, intended for replacement of standard power MOSFETS in DC to 50 KHz applications. Built-in thermal shut-down, linear current limitation and overvoltage clamp protect the chip in harsh environments.

Fault feedback can be detected by monitoring the voltage at the input pin.

Table 1. Device summary

Part number	Order code
VND7N04	VND7N04, VND7N04-1-E, VND7N04-E, VND7N0413TR, VND7N04TR-E
VND7N04-1	VND7N04-1
VNK7N04FM	VNK7N04FM

Contents

1	Block diagram	3
2	Electrical specification	4
	2.1 Absolute maximum rating	4
	2.2 Thermal data	4
	2.3 Electrical characteristics	4
3	Protection features	7
4	Package information	13
5	Revision history	16

1 Block diagram

Figure 1. Block diagram

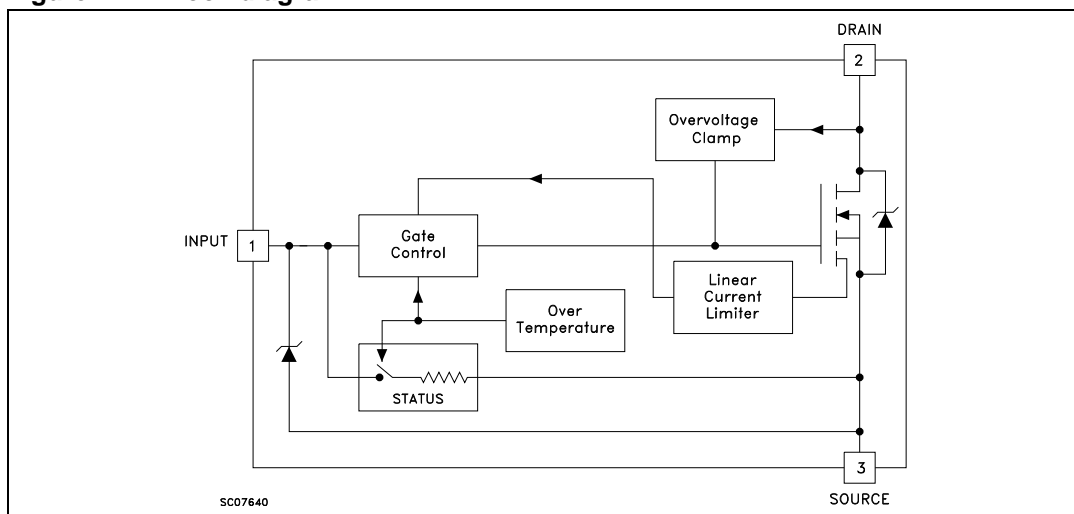

2 Electrical specification

2.1 Absolute maximum rating

Table 2. Absolute maximum rating

Symbol	Parameter	Value		Unit
		DPAK IPAK	SOT-82FM	
V_{DS}	Drain-source voltage ($V_{in} = 0$)	Internally clamped		V
V_{in}	Input voltage	18		V
I_D	Drain current	Internally limited		A
I_R	Reverse DC output current	-7		A
V_{esd}	Electrostatic discharge (C = 100 pF, R=1.5 K Ω)	2000		V
P_{tot}	Total dissipation at $T_c = 25$ °C	60	9	W
T_j	Operating junction temperature	Internally limited		°C
T_c	Case operating temperature	Internally limited		°C
T_{stg}	Storage temperature	-55 to 150		°C

2.2 Thermal data

Table 3. Thermal data

		DPAK/IPAK	SOT82-FM	
$R_{thj-case}$	Thermal resistance junction-case max	3.75	14	°C/W
$R_{thj-amb}$	Thermal resistance junction-ambient max	100	100	°C/W

2.3 Electrical characteristics

Table 4. Electrical characteristics: off

(-40 < T_j < 125 °C unless otherwise specified)

Symbol	Parameter	Test conditions	Min.	Typ.	Max.	Unit
V_{CLAMP}	Drain-source clamp voltage	$I_D = 200$ mA $V_{in} = 0$	32	42	52	V
V_{CLTH}	Drain-source clamp threshold voltage	$I_D = 2$ mA $V_{in} = 0$	31			V
V_{INCL}	Input-source reverse clamp voltage	$I_{in} = -1$ mA	-1.1		-0.25	V
I_{DSS}	Zero input voltage drain current ($V_{in} = 0$)	$V_{DS} = 13$ V $V_{in} = 0$			75	μ A
		$V_{DS} = 25$ V $V_{in} = 0$			200	μ A
I_{ISS}	Supply current from input pin	$V_{DS} = 0$ V $V_{in} = 10$ V		250	550	μ A

Table 5. Electrical characteristics: on

Symbol	Parameter	Test conditions	Min.	Typ.	Max.	Unit
$V_{IN(th)}$	Input threshold voltage	$V_{DS} = V_{in}$ $I_D + I_{in} = 1$ mA	0.8		3	V
$R_{DS(on)}$	Static drain-source on resistance	$V_{in} = 10$ V $I_D = 3.5$ A			0.14	Ω
		$V_{in} = 5$ V $I_D = 3.5$ A			0.28	Ω
		$-40 < T_j < 25$ °C				
		$V_{in} = 10$ V $I_D = 3.5$ A			0.28	Ω
		$V_{in} = 5$ V $I_D = 3.5$ A			0.56	Ω
		$T_j = 125$ °C				

Table 6. Electrical characteristics: dynamic

Symbol	Parameter	Test conditions	Min.	Typ.	Max.	Unit
g_{fs} (1)	Forward transconductance	$V_{DS} = 13$ V $I_D = 3.5$ A	2	5		S
C_{oss}	Output capacitance	$V_{DS} = 13$ V $f = 1$ MHz $V_{in} = 0$		250	500	pF

1. Pulsed: Pulse duration = 300 μ s, duty cycle 1.5 %

Table 7. Electrical characteristics: switching

Symbol	Parameter	Test conditions	Min.	Typ.	Max.	Unit
$t_d(on)$	Turn-on delay time	$V_{DD} = 15$ V $I_d = 3.5$ A		50	150	ns
t_r	Rise time	$V_{gen} = 10$ V $R_{gen} = 10$ Ω		60	180	ns
$t_d(off)$	Turn-off delay time	(see Figure 26)		130	300	ns
t_f	Fall time			50	200	ns
$t_d(on)$	Turn-on delay time	$V_{DD} = 15$ V $I_d = 3.5$ A		140	500	ns
t_r	Rise time	$V_{gen} = 10$ V $R_{gen} = 1000$ Ω		0.4	1.1	μ s
$t_d(off)$	Turn-off delay time	(see Figure 26)		2.5	7	μ s
t_f	Fall time			1	4	μ s
(di/dt) _{on}	Turn-on current slope	$V_{DD} = 15$ V $I_D = 3.5$ A $V_{in} = 10$ V $R_{gen} = 10$ Ω		50		A/ μ s
Q_i	Total input charge	$V_{DD} = 12$ V $I_D = 3.5$ A $V_{in} = 10$ V		18		nC

Table 8. Electrical characteristics: source drain diode

Symbol	Parameter	Test conditions	Min.	Typ.	Max.	Unit
V_{SD} (1)	Forward on voltage	$I_{SD} = 3.5$ A $V_{in} = 0$			1.7	V
t_{rr} (2)	Reverse recovery time	$I_{SD} = 3.5$ A $di/dt = 100$ A/ μ s		40		ns
Q_{rr} (2)	Reverse recovery charge	$V_{DD} = 30$ V $T_j = 25$ °C		0.2		μ C
I_{RRM} (2)	Reverse recovery current	(see test circuit, Figure 28)		3.6		A

1. Pulsed: Pulse duration = 300 μ s, duty cycle 1.5 %

2. Parameters guaranteed by design/characterization

Table 9. Electrical characteristics: protection

Symbol	Parameter	Test conditions	Min.	Typ.	Max.	Unit
I_{lim}	Drain current limit	$V_{in} = 10\text{ V } V_{DS} = 13\text{ V}$	4	7	11	A
		$V_{in} = 5\text{ V } V_{DS} = 13\text{ V}$	4	7	11	A
$t_{dim}^{(1)}$	Step response	$V_{in} = 10\text{ V}$		13	20	μs
	Current limit	$V_{in} = 5\text{ V}$		15	25	μs
$T_{jsh}^{(1)}$	Overtemperature shutdown		150			$^{\circ}\text{C}$
$T_{jrs}^{(1)}$	Overtemperature reset		135			$^{\circ}\text{C}$
$I_{gf}^{(1)}$	Fault sink current	$V_{in} = 10\text{ V } V_{DS} = 13\text{ V}$		50		mA
		$V_{in} = 5\text{ V } V_{DS} = 13\text{ V}$		20		mA
$E_{as}^{(1)}$	Single pulse avalanche energy	starting $T_j = 25^{\circ}\text{C } V_{DD} = 20\text{ V}$ $V_{in} = 10\text{ V } R_{gen} = 1\text{ K}\Omega L = 30\text{ mH}$	0.4			J

1. Pulsed: Pulse duration = 300 μs , duty cycle 1.5 %

3 Protection features

During normal operation, the Input pin is electrically connected to the gate of the internal power MOSFET. The device then behaves like a standard power MOSFET and can be used as a switch from DC to 50 KHz. The only difference from the user's standpoint is that a small DC current (I_{ISS}) flows into the Input pin in order to supply the internal circuitry.

The device integrates:

- Overvoltage clamp protection: internally set at 42 V, along with the rugged avalanche characteristics of the Power MOSFET stage give this device unrivalled ruggedness and energy handling capability. This feature is mainly important when driving inductive loads.
- Linear current limiter circuit: limits the drain current I_D to I_{lim} whatever the Input pin voltage. When the current limiter is active, the device operates in the linear region, so power dissipation may exceed the capability of the heatsink. Both case and junction temperatures increase, and if this phase lasts long enough, junction temperature may reach the overtemperature threshold T_{jsh} .
- Overtemperature and short circuit protection: these are based on sensing the chip temperature and are not dependent on the input voltage. The location of the sensing element on the chip in the power stage area ensures fast, accurate detection of the junction temperature. Overtemperature cutout occurs at minimum 150 °C. The device is automatically restarted when the chip temperature falls below 135 °C.
- Status feedback: in the case of an overtemperature fault condition, a Status Feedback is provided through the Input pin. The internal protection circuit disconnects the input from the gate and connects it instead to ground via an equivalent resistance of 100 Ω . The failure can be detected by monitoring the voltage at the Input pin, which will be close to ground potential.

Additional features of this device are ESD protection according to the Human Body model and the ability to be driven from a TTL Logic circuit (with a small increase in $R_{DS(on)}$).

Figure 2. Thermal impedance for DPAK / IPAK

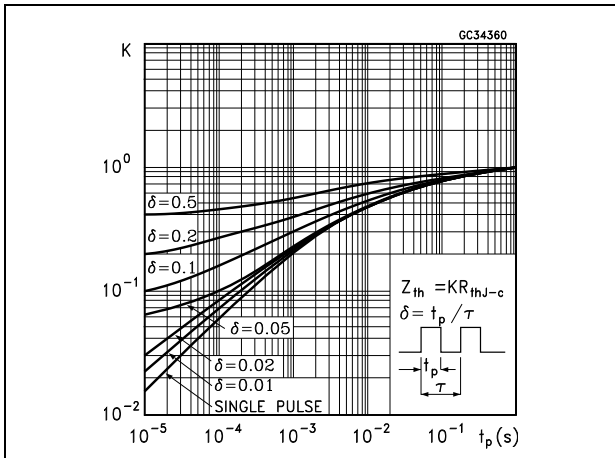

Figure 3. Derating curve

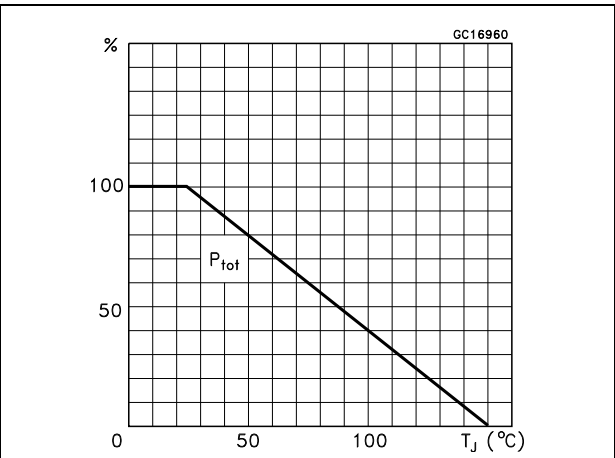

Figure 4. Output characteristics

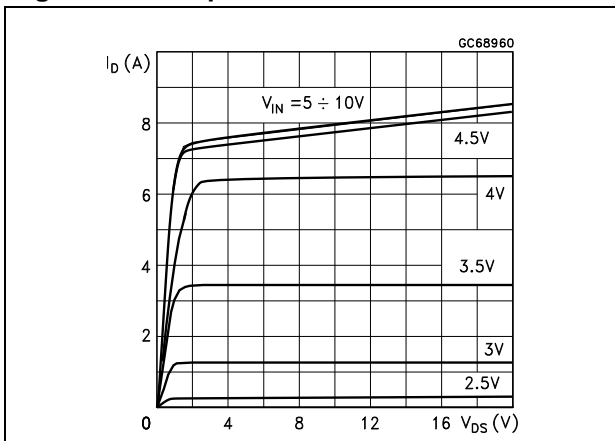

Figure 5. Transconductance

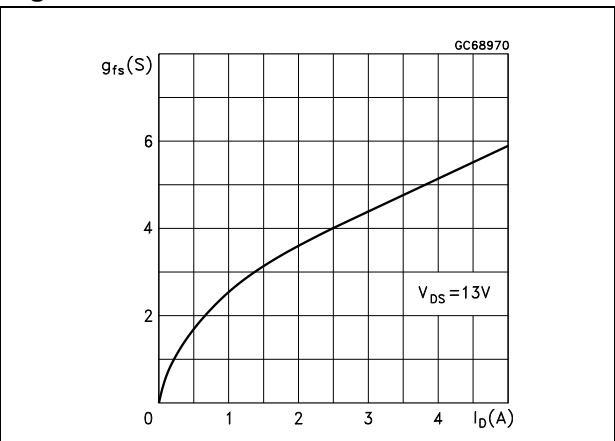

Figure 6. Static drain-source on resistance vs input voltage

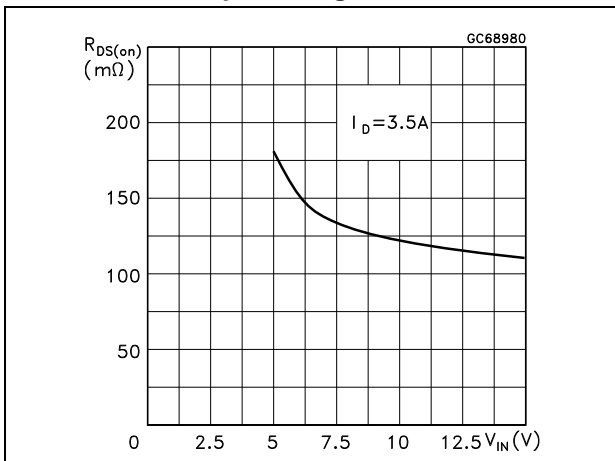

Figure 7. Static drain-source on resistance (part 1/2)

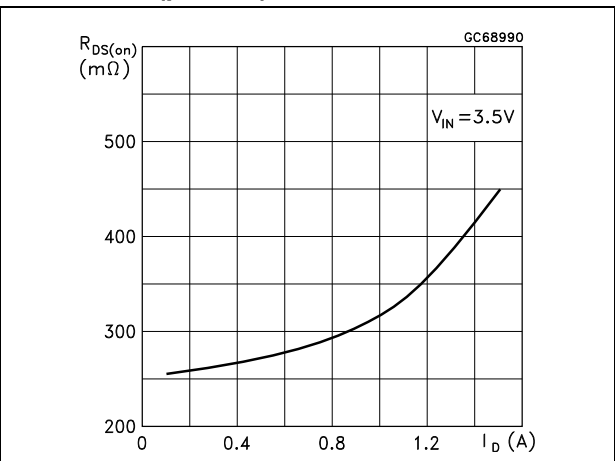

Figure 8. Static drain-source on resistance (part 2/2)

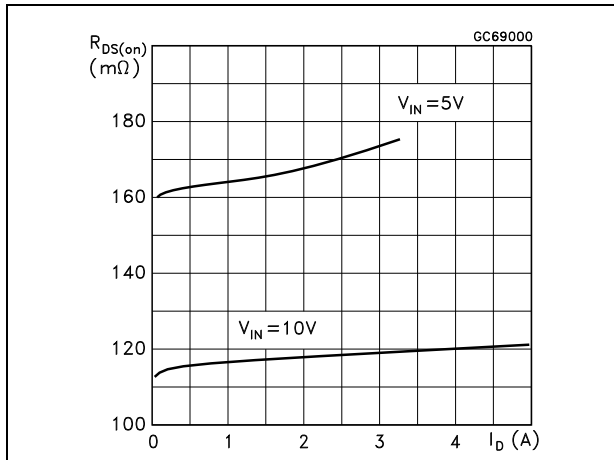

Figure 9. Input charge vs input voltage

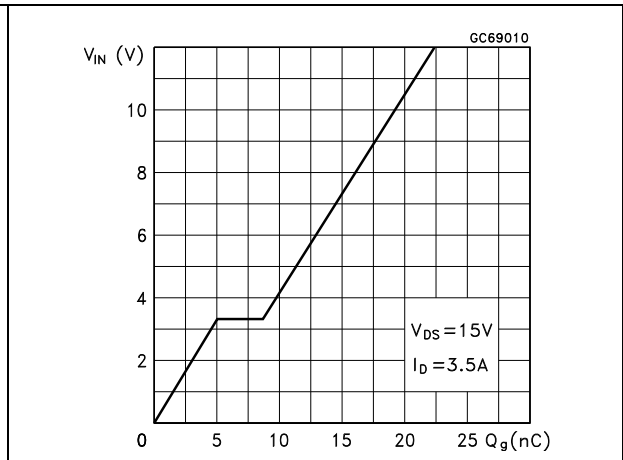

Figure 10. Capacitance variations

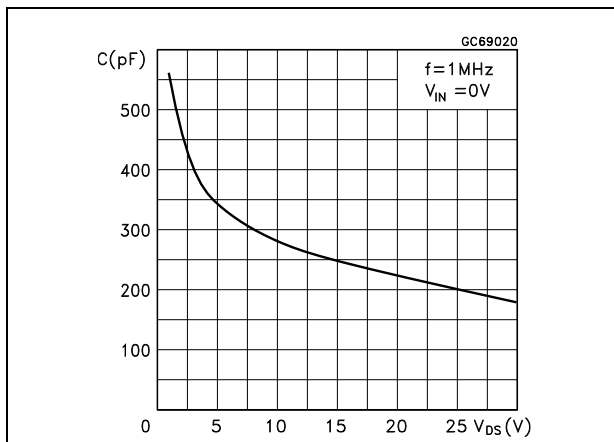

Figure 11. Normalized input threshold voltage vs temperature

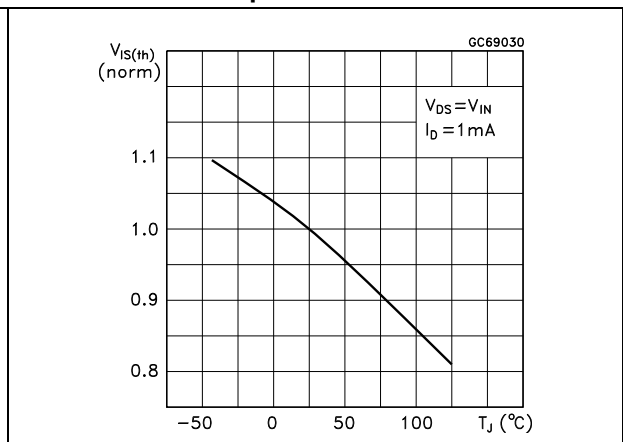

Figure 12. Normalized on resistance vs temperature (part 1/2)

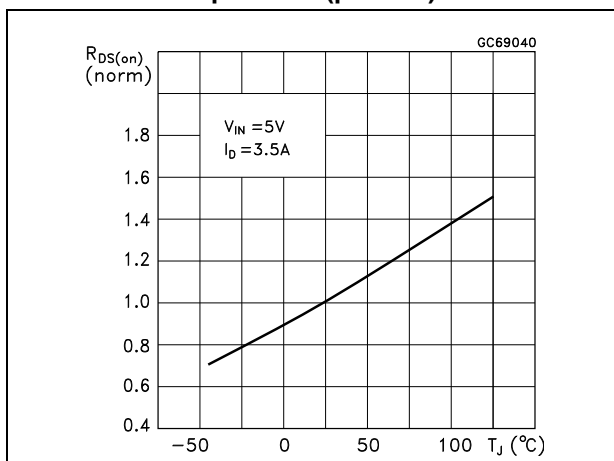

Figure 13. Normalized on resistance vs temperature (part 2/2)

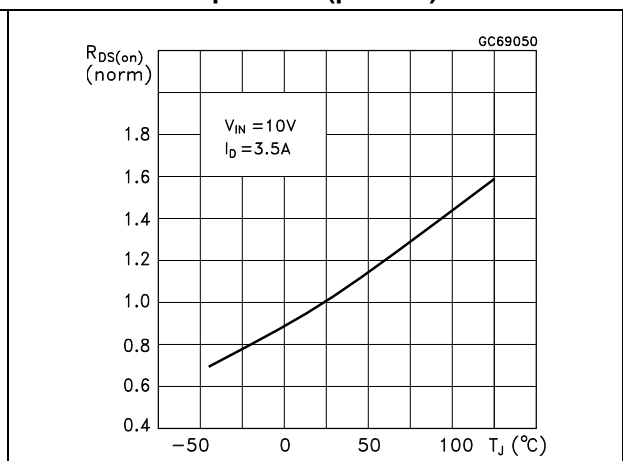

Figure 14. Turn-on current slope(part 1/2)

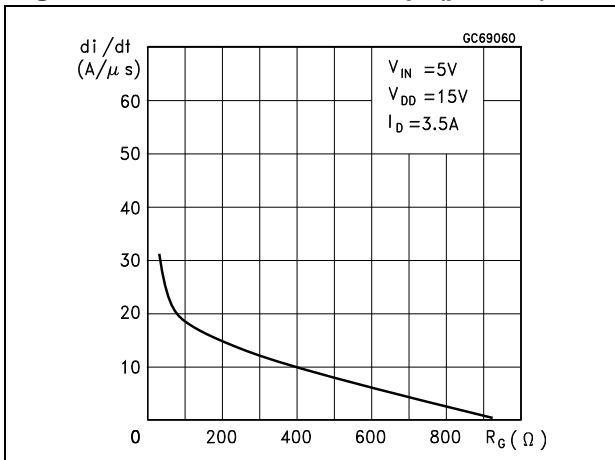

Figure 15. Turn-on current slope(part 2/2)

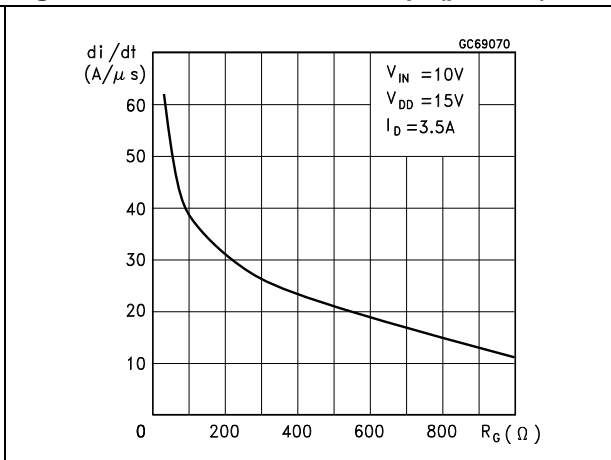

Figure 16. Turn-off drain-source voltage slope (part 1/2)

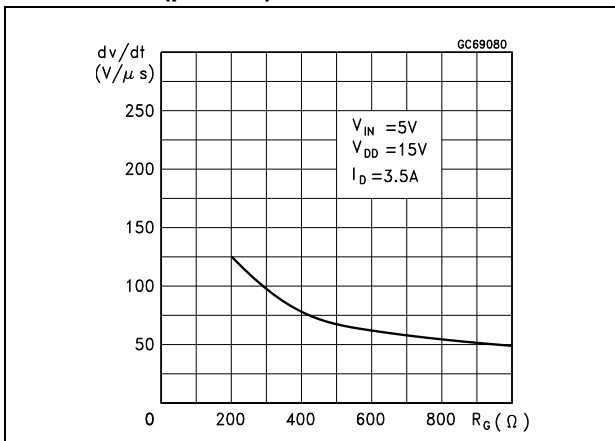

Figure 17. Turn-off drain-source voltage slope (part 2/2)

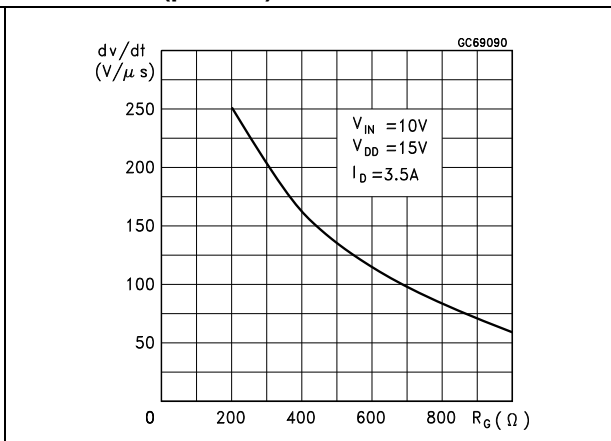

Figure 18. Switching time resistive load (part 1/3)

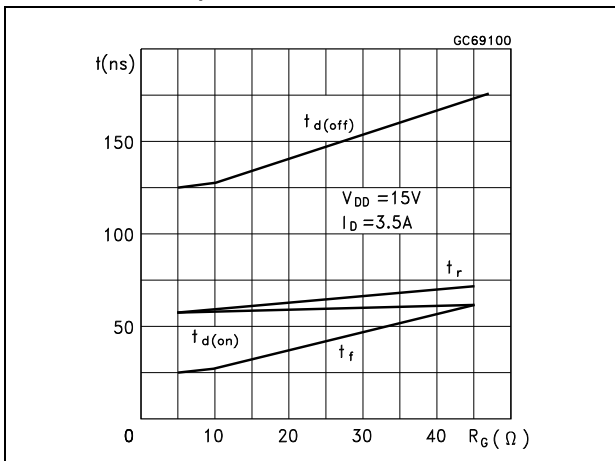

Figure 19. Switching time resistive load (part 2/3)

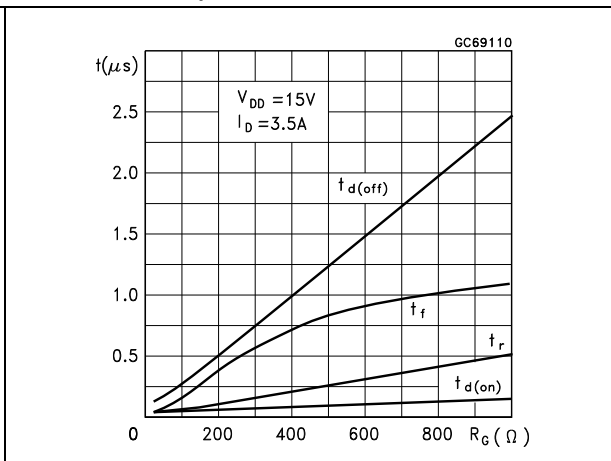

Figure 20. Switching time resistive load (part 3/3)

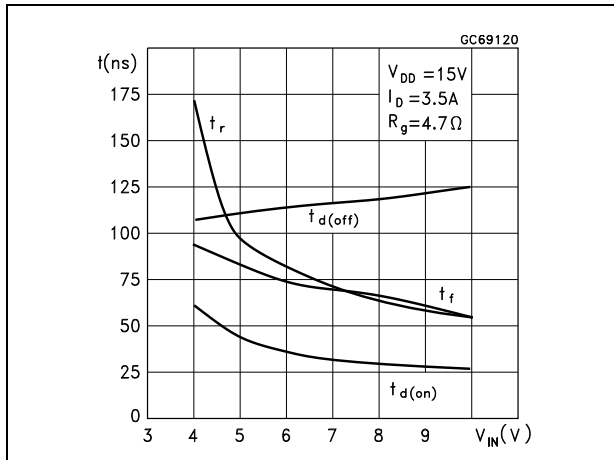

Figure 22. Step response current limit

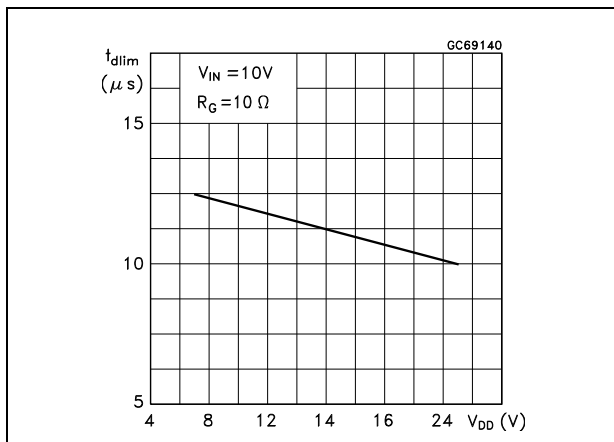

Figure 23. Source drain diode forward characteristics



Figure 21. Current limit vs junction temperature

Figure 21. Current limit vs junction temperature

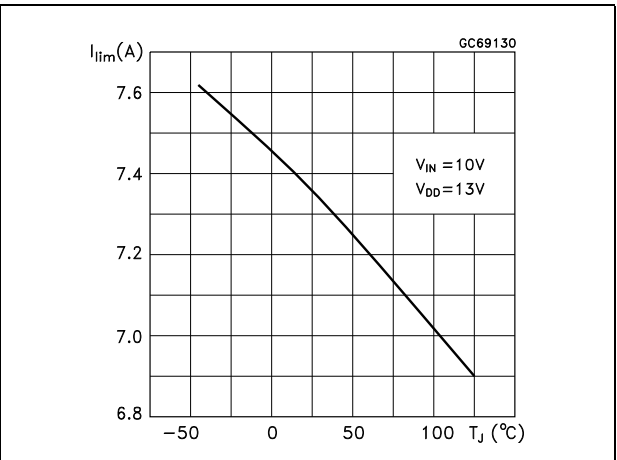

Figure 22. Step response current limit

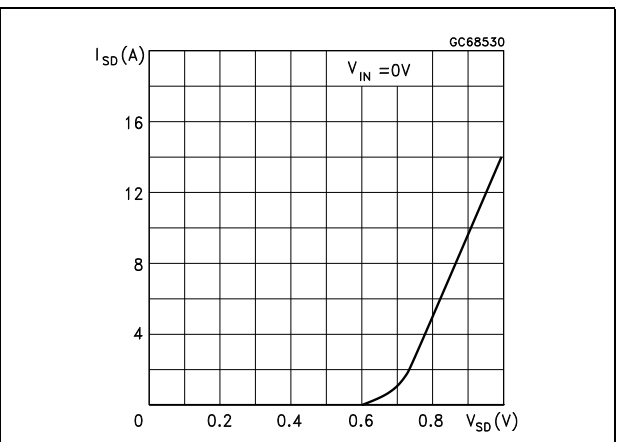

Figure 23. Source drain diode forward characteristics

Figure 24. Unclamped inductive load test circuits

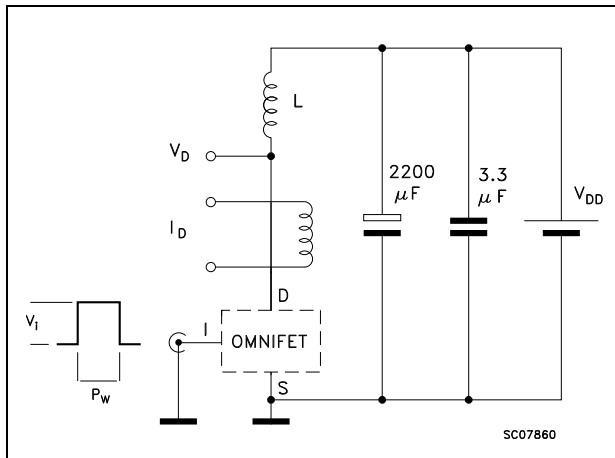

Figure 25. Unclamped inductive waveforms

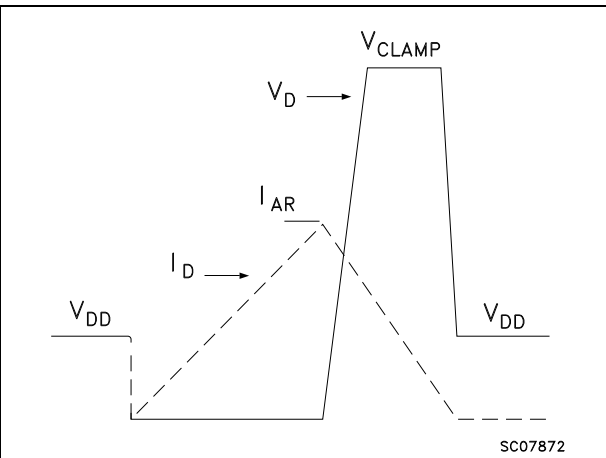

Figure 26. Switching times test circuits for resistive load

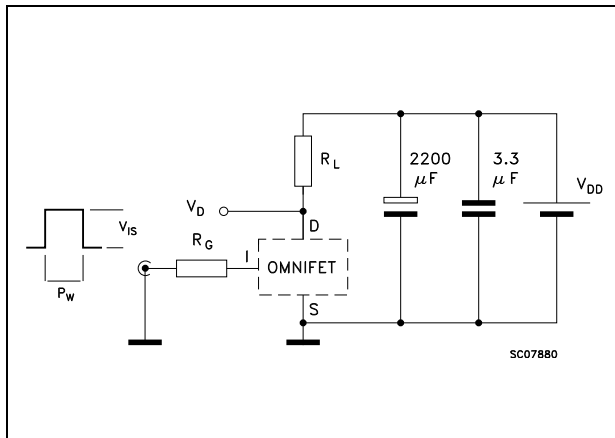

Figure 27. Input charge test circuit

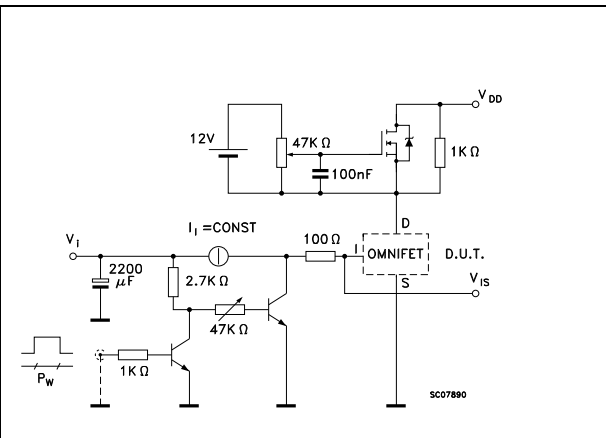

Figure 28. Test circuit for inductive load switching and diode recovery times

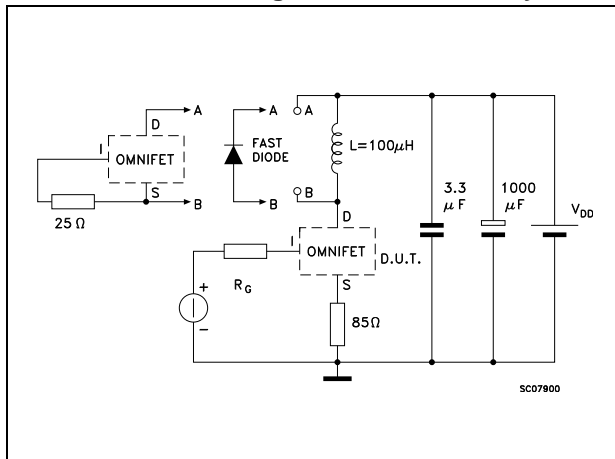
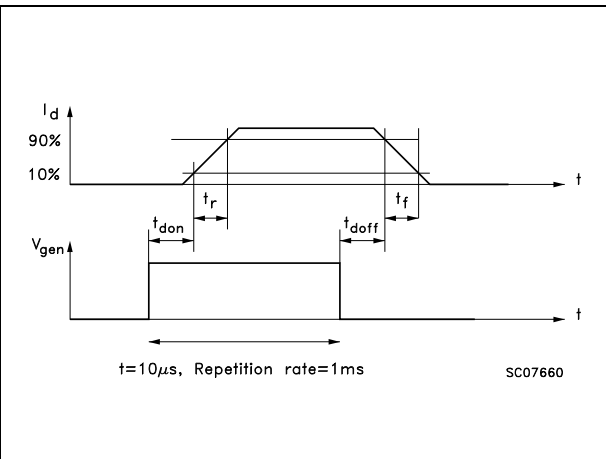

Figure 29. Waveforms



4 Package information

In order to meet environmental requirements, ST offers these devices in different grades of ECOPACK® packages, depending on their level of environmental compliance. ECOPACK® specifications, grade definitions and product status are available at: www.st.com.

ECOPACK® is an ST trademark.

Figure 30. TO-252 (DPAK) mechanical data

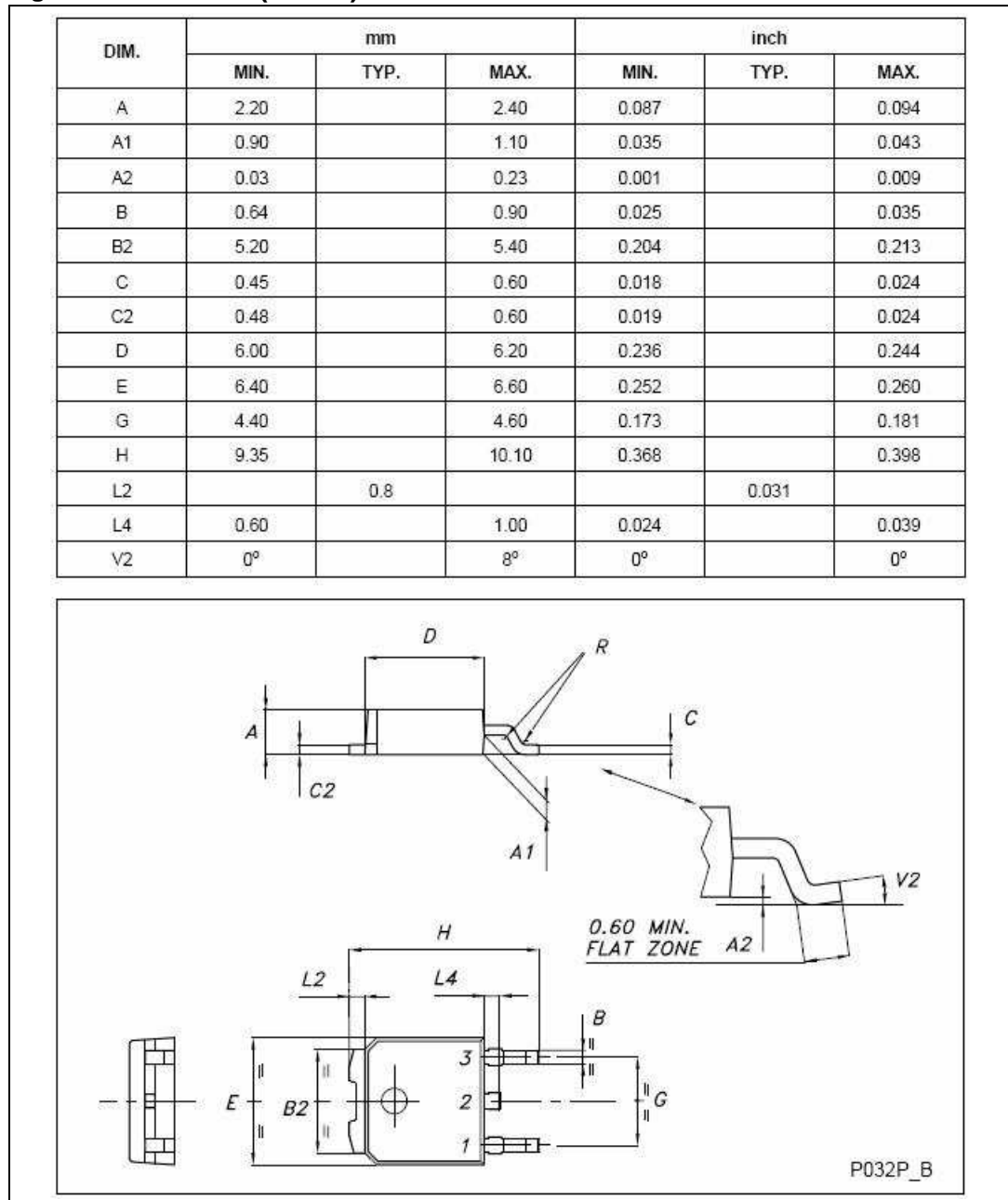
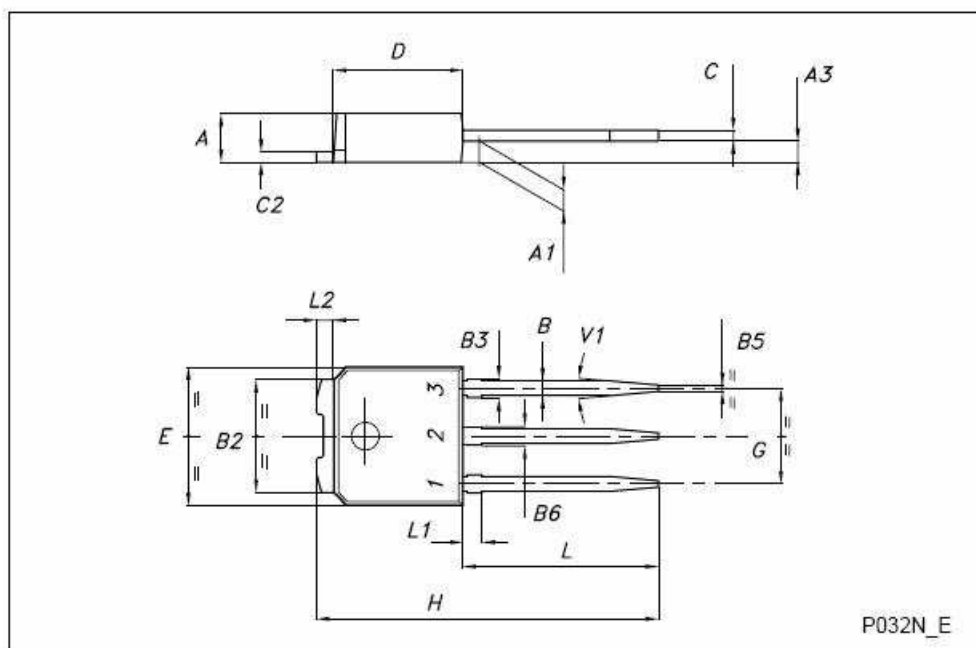

Figure 31. TO-251 (IPAK) mechanical data

DIM.	mm			inch		
	MIN.	TYP.	MAX.	MIN.	TYP.	MAX.
A	2.20		2.40	0.087		0.094
A1	0.90		1.10	0.035		0.043
A3	0.70		1.30	0.028		0.051
B	0.64		0.90	0.025		0.035
B2	5.20		5.40	0.204		0.213
B3			0.85			0.033
B5		0.30			0.012	
B6			0.95			0.037
C	0.45		0.60	0.018		0.024
C2	0.48		0.60	0.019		0.024
D	6.00		6.20	0.237		0.244
E	6.40		6.60	0.252		0.260
G	4.40		4.60	0.173		0.181
H	15.90		16.30	0.626		0.642
L	9.00		9.40	0.354		0.370
L1	0.80		1.20	0.031		0.047
L2		0.80	1.00		0.031	0.039
V1		10°			10°	



P032N_E

Figure 32. SOT-82FM mechanical data

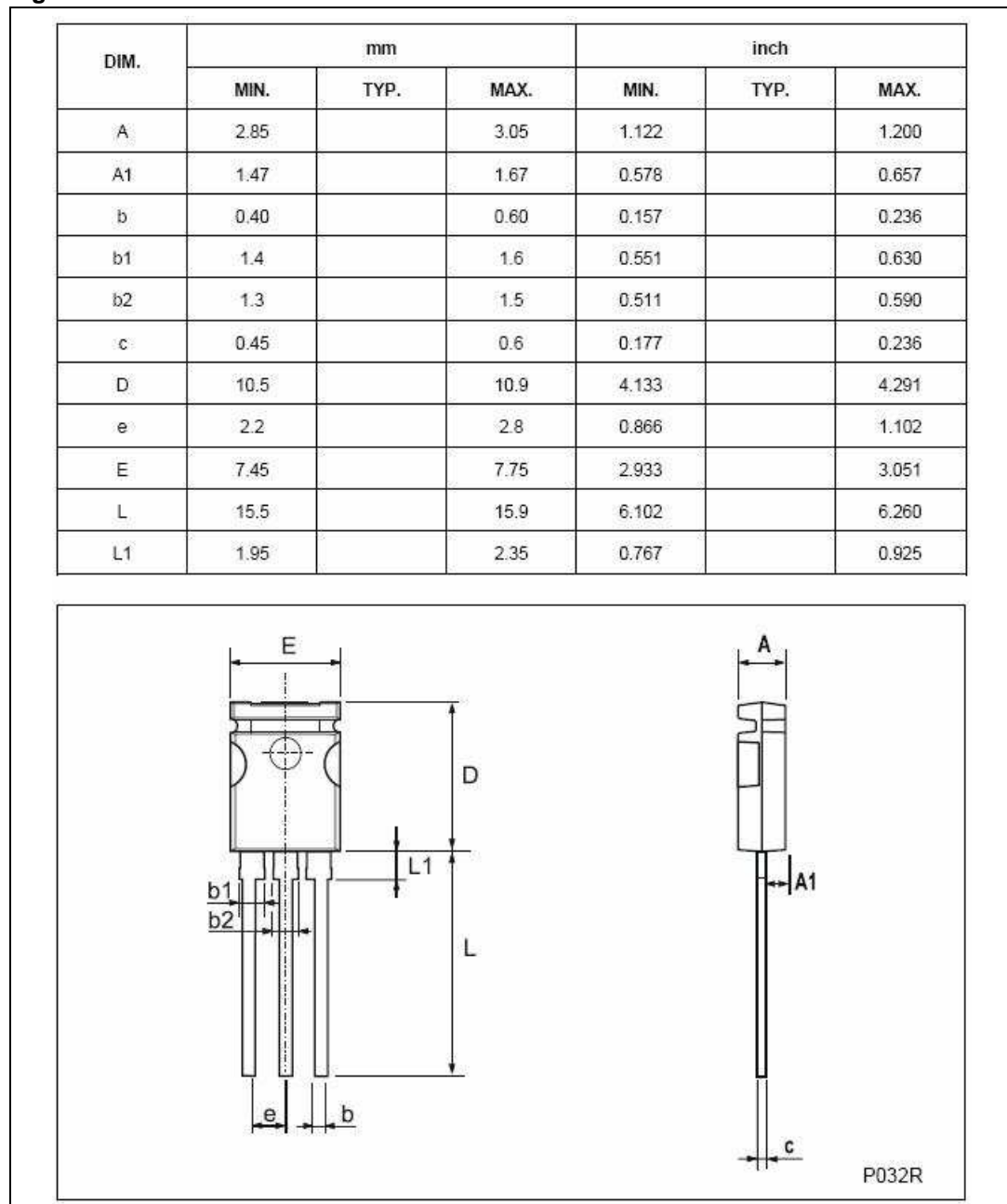

5 Revision history

Table 10. Document revision history

Date	Revision	Changes
21-Jun-2004	0.1	Initial release.
18-Mar-2009	1	Document reformatted. Added Table 1: Device summary on page 1 . Updated Section 4: Package information on page 13

5 Revision history

Table 10. Document revision history

Date	Revision	Changes
21-Jun-2004	1	Initial release.
25-Sep-2013	2	Updated Disclaimer

Please Read Carefully:

Information in this document is provided solely in connection with ST products. STMicroelectronics NV and its subsidiaries ("ST") reserve the right to make changes, corrections, modifications or improvements, to this document, and the products and services described herein at any time, without notice.

All ST products are sold pursuant to ST's terms and conditions of sale.

Purchasers are solely responsible for the choice, selection and use of the ST products and services described herein, and ST assumes no liability whatsoever relating to the choice, selection or use of the ST products and services described herein.

No license, express or implied, by estoppel or otherwise, to any intellectual property rights is granted under this document. If any part of this document refers to any third party products or services it shall not be deemed a license grant by ST for the use of such third party products or services, or any intellectual property contained therein or considered as a warranty covering the use in any manner whatsoever of such third party products or services or any intellectual property contained therein.

UNLESS OTHERWISE SET FORTH IN ST'S TERMS AND CONDITIONS OF SALE ST DISCLAIMS ANY EXPRESS OR IMPLIED WARRANTY WITH RESPECT TO THE USE AND/OR SALE OF ST PRODUCTS INCLUDING WITHOUT LIMITATION IMPLIED WARRANTIES OF MERCHANTABILITY, FITNESS FOR A PARTICULAR PURPOSE (AND THEIR EQUIVALENTS UNDER THE LAWS OF ANY JURISDICTION), OR INFRINGEMENT OF ANY PATENT, COPYRIGHT OR OTHER INTELLECTUAL PROPERTY RIGHT.

ST PRODUCTS ARE NOT DESIGNED OR AUTHORIZED FOR USE IN: (A) SAFETY CRITICAL APPLICATIONS SUCH AS LIFE SUPPORTING, ACTIVE IMPLANTED DEVICES OR SYSTEMS WITH PRODUCT FUNCTIONAL SAFETY REQUIREMENTS; (B) AERONAUTIC APPLICATIONS; (C) AUTOMOTIVE APPLICATIONS OR ENVIRONMENTS, AND/OR (D) AEROSPACE APPLICATIONS OR ENVIRONMENTS. WHERE ST PRODUCTS ARE NOT DESIGNED FOR SUCH USE, THE PURCHASER SHALL USE PRODUCTS AT PURCHASER'S SOLE RISK, EVEN IF ST HAS BEEN INFORMED IN WRITING OF SUCH USAGE, UNLESS A PRODUCT IS EXPRESSLY DESIGNATED BY ST AS BEING INTENDED FOR "AUTOMOTIVE, AUTOMOTIVE SAFETY OR MEDICAL" INDUSTRY DOMAINS ACCORDING TO ST PRODUCT DESIGN SPECIFICATIONS. PRODUCTS FORMALLY ESCC, QML OR JAN QUALIFIED ARE DEEMED SUITABLE FOR USE IN AEROSPACE BY THE CORRESPONDING GOVERNMENTAL AGENCY.

Resale of ST products with provisions different from the statements and/or technical features set forth in this document shall immediately void any warranty granted by ST for the ST product or service described herein and shall not create or extend in any manner whatsoever, any liability of ST.

ST and the ST logo are trademarks or registered trademarks of ST in various countries.

Information in this document supersedes and replaces all information previously supplied.

The ST logo is a registered trademark of STMicroelectronics. All other names are the property of their respective owners.

© 2013 STMicroelectronics - All rights reserved

STMicroelectronics group of companies

Australia - Belgium - Brazil - Canada - China - Czech Republic - Finland - France - Germany - Hong Kong - India - Israel - Italy - Japan - Malaysia - Malta - Morocco - Philippines - Singapore - Spain - Sweden - Switzerland - United Kingdom - United States of America

www.st.com



X-ON Electronics

Largest Supplier of Electrical and Electronic Components

Click to view similar products for [MOSFET](#) category:

Click to view products by [STMicroelectronics](#) manufacturer:

Other Similar products are found below :

[614233C](#) [648584F](#) [IRFD120](#) [JANTX2N5237](#) [2N7000](#) [FCA20N60_F109](#) [FDZ595PZ](#) [2SK2545\(Q,T\)](#) [405094E](#) [423220D](#)
[TPCC8103,L1Q\(CM](#) [MIC4420CM-TR](#) [VN1206L](#) [614234A](#) [715780A](#) [NTNS3166NZT5G](#) [SSM6J414TU,LF\(T](#) [751625C](#)
[IPS70R2K0CEAKMA1](#) [BUK954R8-60E](#) [DMN3404LQ-7](#) [NTE6400](#) [SQJ402EP-T1-GE3](#) [2SK2614\(TE16L1,Q\)](#) [2N7002KW-FAI](#)
[DMN1017UCP3-7](#) [EFC2J004NUZTDG](#) [ECH8691-TL-W](#) [FCAB21350L1](#) [P85W28HP2F-7071](#) [DMN1053UCP4-7](#) [NTE221](#) [NTE2384](#)
[NTE2903](#) [NTE2941](#) [NTE2945](#) [NTE2946](#) [NTE2960](#) [NTE2967](#) [NTE2969](#) [NTE2976](#) [NTE455](#) [NTE6400A](#) [NTE2910](#) [NTE2916](#) [NTE2956](#)
[NTE2911](#) [US6M2GTR](#) [TK10A80W,S4X\(S](#) [SSM6P69NU,LF](#)