



# VNQ860 VNQ860SP

## QUAD CHANNEL HIGH SIDE DRIVER

TYPE	$R_{DS(on)}$ (*)	$I_{OUT}$	$V_{CC}$
VNQ860	270m $\Omega$	0.25A	36V
VNQ860SP			

(\*) Per each channel

- CMOS COMPATIBLE I/Os
- UNDERVOLTAGE & OVERVOLTAGE SHUT- DOWN
- SHORTED LOAD PROTECTION
- THERMAL SHUTDOWN
- VERY LOW STAND-BY CURRENT
- PROTECTION AGAINST LOSS OF GROUND

### DESCRIPTION

The VNQ860, VNQ860SP are monolithic devices made using STMicroelectronics VIPower M0-3 Technology, intended for driving any kind load with one side connected to ground. Active current limitation combined with thermal shutdown and automatic restart protect the device against overload. Device automatically turns off in case of ground pin disconnection. This device is

### BLOCK DIAGRAM

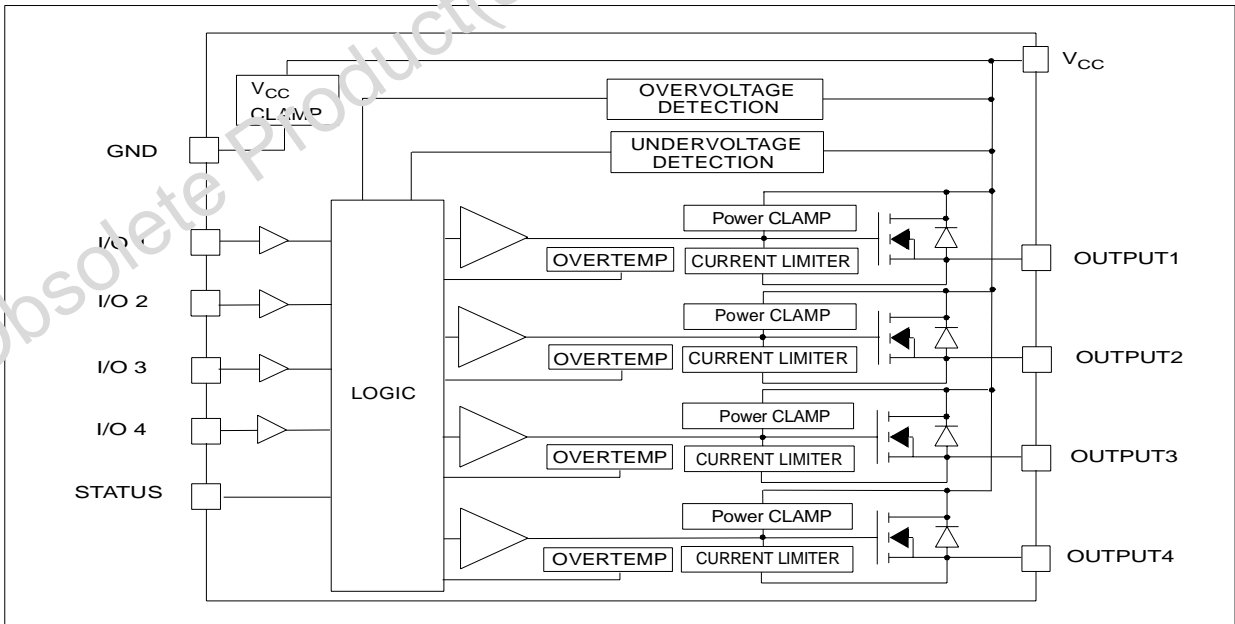

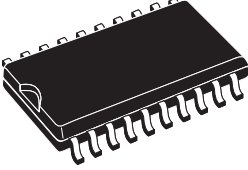

**SO-20**

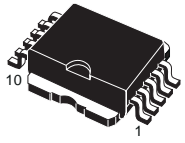

**PowerSO-10™**

ORDER CODES		
PACKAGE	TUBE	T&R
SO-20	VNQ860	VNQ86013TR
PowerSO-10	VNQ860SP	VNQ860SP13TR

especially suitable for industrial applications in norms conformity with IEC1131 (Programmable Controllers International Standard).

Rev. 1

**ABSOLUTE MAXIMUM RATING**

Symbol	Parameter	Value		Unit
		SO-20	PowerSO-10	
$V_{CC}$	DC supply voltage	41		V
$-V_{CC}$	Reverse DC supply voltage	- 0.3		V
$-I_{GND}$	DC reverse ground pin current	- 200		mA
$I_{OUT}$	DC output current	Internally Limited		A
$-I_{OUT}$	Reverse DC output current	- 2		A
$I_{IN}$	DC Input current	+/- 10		mA
$V_{IN}$	Input voltage range	-3/+ $V_{CC}$		V
$V_{STAT}$	DC Status voltage	+ $V_{CC}$		V
$V_{ESD}$	Electrostatic discharge (R=1.5 K $\Omega$ ; C=100 pF)	2000		V
$P_{tot}$	Power dissipation $T_C=25^\circ\text{C}$	16	90	W
$T_j$	Junction operating temperature	Internally Limited		$^\circ\text{C}$
$T_c$	Case operating temperature	- 40 to 150		$^\circ\text{C}$
$T_{stg}$	Storage temperature	- 55 to 150		$^\circ\text{C}$

**CONFIGURATION DIAGRAM (TOP VIEW) & SUGGESTED CONNECTIONS FOR UNUSED AND N.C. PINS**

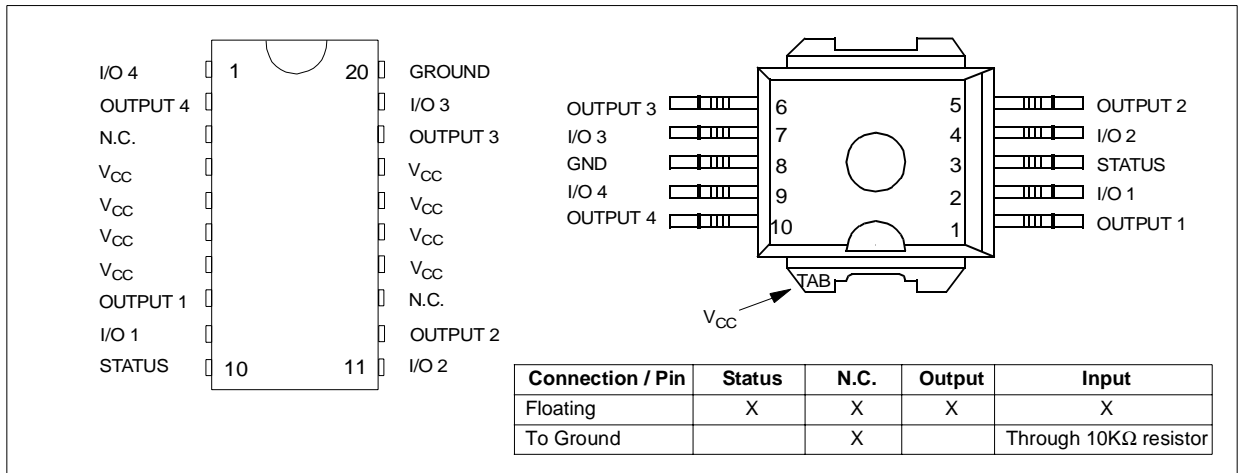

**CURRENT AND VOLTAGE CONVENTIONS**

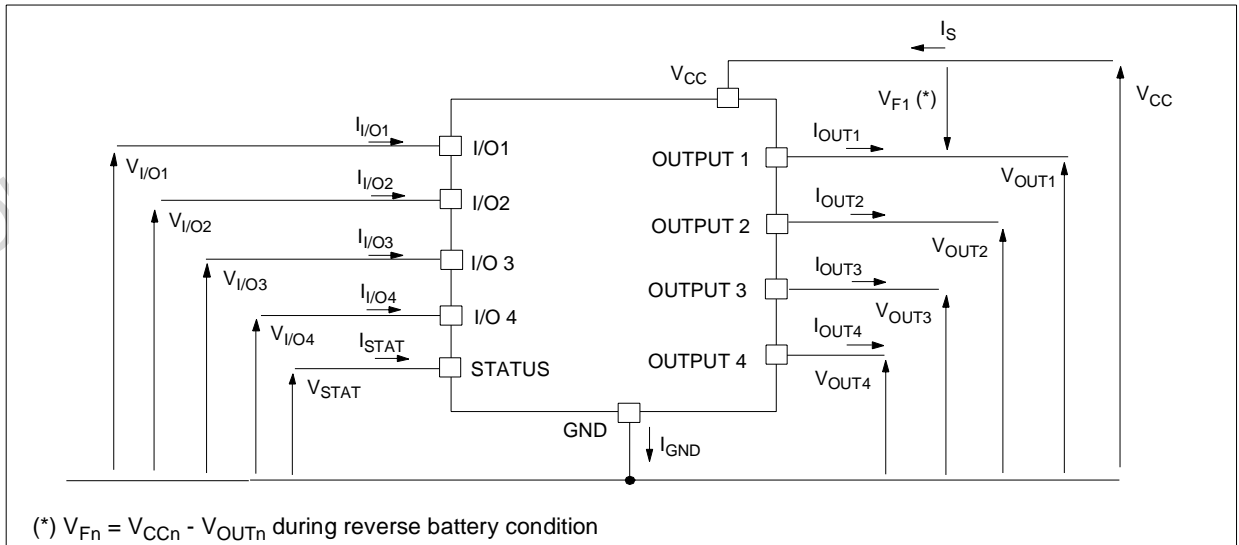

## THERMAL DATA

Symbol	Parameter	Value		Unit
		SO-20	PowerSO-10	
$R_{thj-amb}$	Thermal resistance junction-pins (MAX)	8	-	$^{\circ}\text{C}/\text{W}$
$R_{thj-case}$	Thermal resistance junction-ambient (MAX)	58	52 <sup>(1)</sup>	$^{\circ}\text{C}/\text{W}$
			37 <sup>(2)</sup>	$^{\circ}\text{C}/\text{W}$
$R_{thj-pin}$	Thermal resistance junction-case (MAX)	-	1.4	$^{\circ}\text{C}/\text{W}$

<sup>(1)</sup> When mounted on FR4 printed circuit board with  $0.5\text{cm}^2$  of copper area (at least  $35\mu$  thick) connected to all  $V_{CC}$  pins.

<sup>(2)</sup> When mounted on FR4 printed circuit board with  $6\text{cm}^2$  of copper area (at least  $35\mu$  thick) connected to all  $V_{CC}$  pins.

ELECTRICAL CHARACTERISTICS ( $8\text{V} < V_{CC} < 36\text{V}$ ;  $-40^{\circ}\text{C} < T_j < 150^{\circ}\text{C}$ ; unless otherwise specified)

## POWER

Symbol	Parameter	Test Conditions	Min	Typ	Max	Unit
$V_{CC}$	Operating supply voltage		5.5		36	V
$V_{USD}$	Undervoltage shut-down		3	4	5.5	V
$V_{OV}$	Overvoltage shut-down		36	42	48	V
$R_{ON}$	On state resistance (per channel)	$I_{OUT}=0.25\text{A}$ ; $T_j=25^{\circ}\text{C}$			270	$\text{m}\Omega$
		$I_{OUT}=0.25\text{A}$			540	$\text{m}\Omega$
$I_S$	Supply current	Off state; $V_{CC}=24\text{V}$ ; $T_c=25^{\circ}\text{C}$		70	120	$\mu\text{A}$
		On state (all channels on)		5	10	$\text{mA}$
$I_{LGND}$	Output current	$V_{CC}-V_{STAT}=V_{IN}=V_{GND}=24\text{V}$ $V_{OUT}=0\text{V}$			1	$\text{mA}$
$I_{L(off)}$	Off state output current	$V_{IN}=V_{OUT}=0\text{V}$	0		10	$\mu\text{A}$
$I_{OUTleak}$	Off state output leakage current	$V_{IN}=V_{GND}=0\text{V}$ ; $V_{CC}=V_{OUT}=24\text{V}$ ; $T_{amb}=25^{\circ}\text{C}$			240	$\mu\text{A}$
$I_{OUTleak}$	Off state output leakage current	$V_{IN}=V_{GND}=0\text{V}$ ; $V_{CC}=24\text{V}$ ; $V_{OUT}=10\text{V}$ ; $T_{amb}=25^{\circ}\text{C}$			100	$\mu\text{A}$

SWITCHING ( $V_{CC}=24\text{V}$ ) (Per channel)

Symbol	Parameter	Test Conditions	Min	Typ	Max	Unit
$t_{D(on)}$	Turn-on delay time	$R_L=96\Omega$ from $V_{IN}$ rising edge to $V_{OUT}=2.4\text{V}$		10		$\mu\text{s}$
$t_{D(off)}$	Turn-off delay time	$R_L=96\Omega$ from $V_{IN}$ falling edge to $V_{OUT}=21.6\text{V}$		40		$\mu\text{s}$
$(dV_{OUT}/dt)_{on}$	Turn-on voltage slope	$R_L=96\Omega$ from $V_{OUT}=2.4\text{V}$ to $19.2\text{V}$		0.75		$\text{V}/\mu\text{s}$
$(dV_{OUT}/dt)_{off}$	Turn-off voltage slope	$R_L=96\Omega$ from $V_{OUT}=21.6\text{V}$ to $2.4\text{V}$		0.25		$\text{V}/\mu\text{s}$

## PROTECTIONS (Per channel)

Symbol	Parameter	Test Conditions	Min	Typ	Max	Unit
$I_{lim}$	Current limitation		0.35	0.7	1.1	A
$T_{(hyst)}$	Thermal hysteresis		7	15		$^{\circ}\text{C}$
$T_{TSD}$	Thermal shut-down temperature		150	175	200	$^{\circ}\text{C}$
$T_R$	Reset temperature		135			$^{\circ}\text{C}$
$V_{demag}$	Turn-off output clamp voltage	$I_{OUT}=0.25\text{A}$	$V_{CC}-47$	$V_{CC}-52$	$V_{CC}-59$	V

**ELECTRICAL CHARACTERISTICS** (continued)

**LOGIC INPUT** (Per channel)

Symbol	Parameter	Test Conditions	Min	Typ	Max	Unit
$V_{IL}$	Low level input voltage				1.25	V
$I_{IL}$	Low level input current	$V_{IN}=1.25V$	1			$\mu A$
$V_{IH}$	High level input voltage		3.25			V
$I_{IH}$	High level input current	$V_{IN}=3.25V$			10	$\mu A$
$V_{I(hyst)}$	Input hysteresis Voltage		0.5			V
$I_{IN}$	Input current	$V_{IN}=V_{CC}=36V$			200	$\mu A$
$V_{OL}$	I/O Output voltage	$I_{IN}=5mA$ (Fault condition)			1	V

**STATUS PIN**

Symbol	Parameter	Test conditions	Min	Typ	Max	Unit
$V_{STAT}$	Status low output voltage	$I_{STAT}=5mA$ (Fault condition)			1	V
$I_{LSTAT}$	Status leakage current	Normal operation; $V_{STAT}=V_{CC}=36V$			10	$\mu A$
$C_{STAT}$	Status pin input capacitance	Normal operation; $V_{STAT}=5V$			100	pF

 **$V_{CC}$  - OUTPUT DIODE**

Symbol	Parameter	Test Conditions	Min	Typ	Max	Unit
$V_F$	Forward on Voltage	$-I_{OUT}=0.3A$ ; $T_j=150^\circ C$			0.6	V

**TRUTH TABLE**

CONDITIONS	MCOUTn	I/On	OUTPUTn	STATUS
Normal operation	L	L	L	H
	H	H	H	H
Current limitation	L	L	L	H
	H	H	X	H
Overtemperature	L	L	L	L
	H	Driven low	L	L
Undervoltage	L	L	L	X
	H	H	L	X
Overvoltage	L	L	L	H
	H	H	L	H

**SWITCHING CHARACTERISTICS**

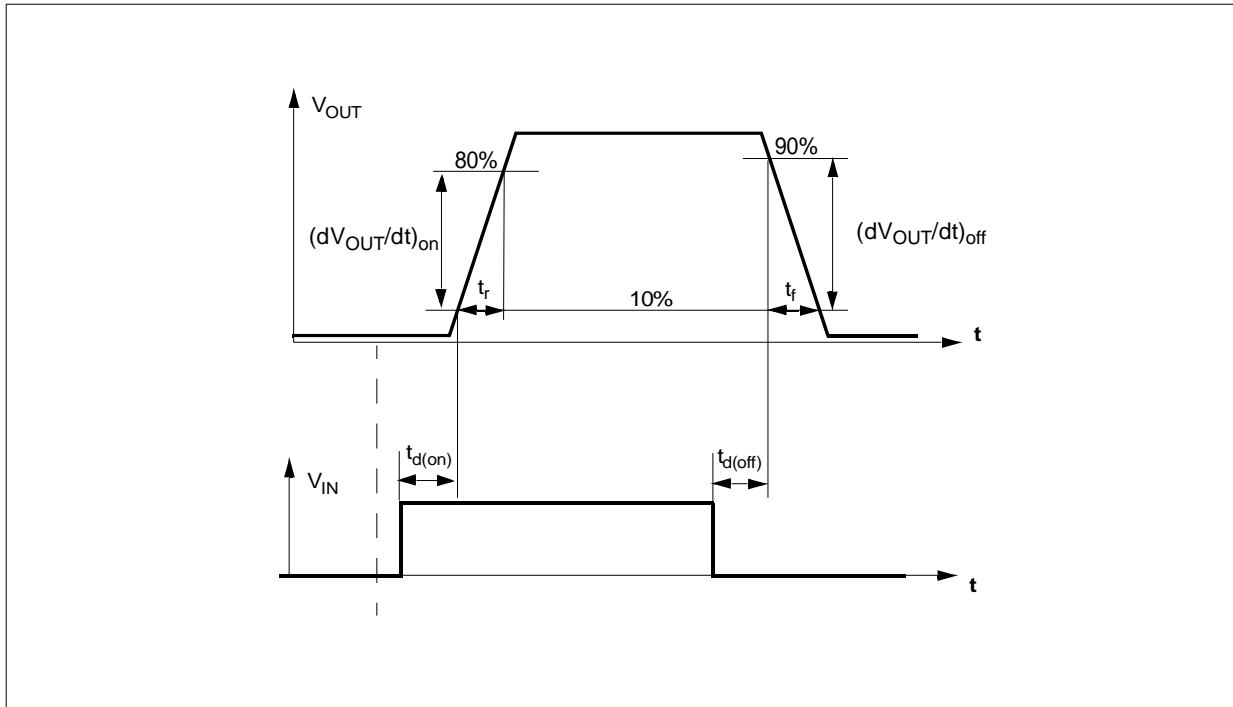

**Typical application schematic**

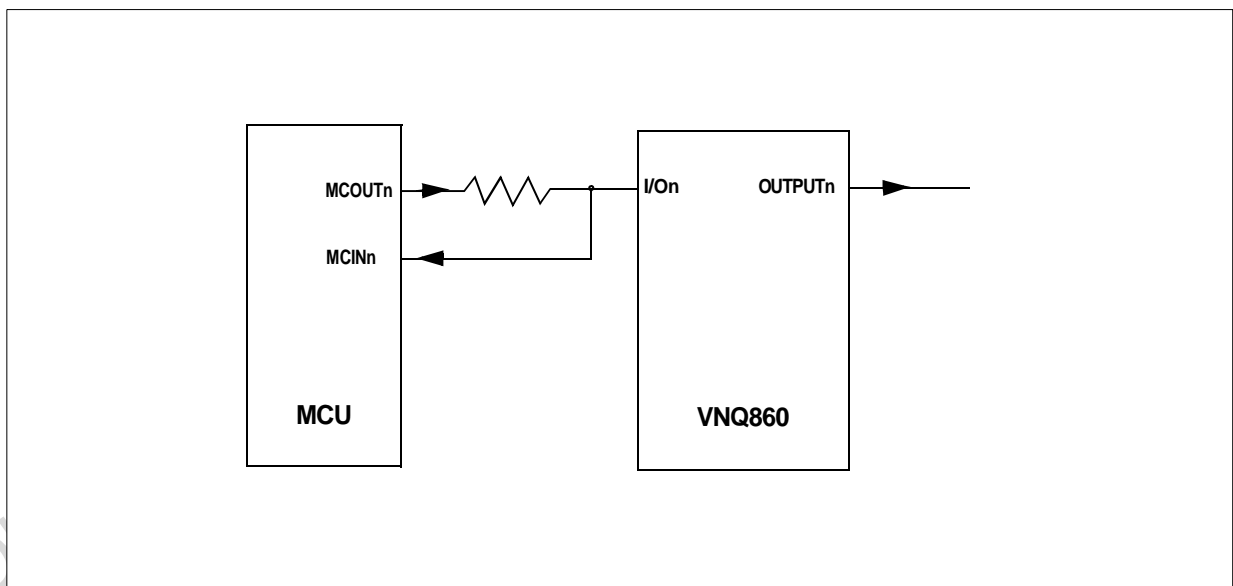
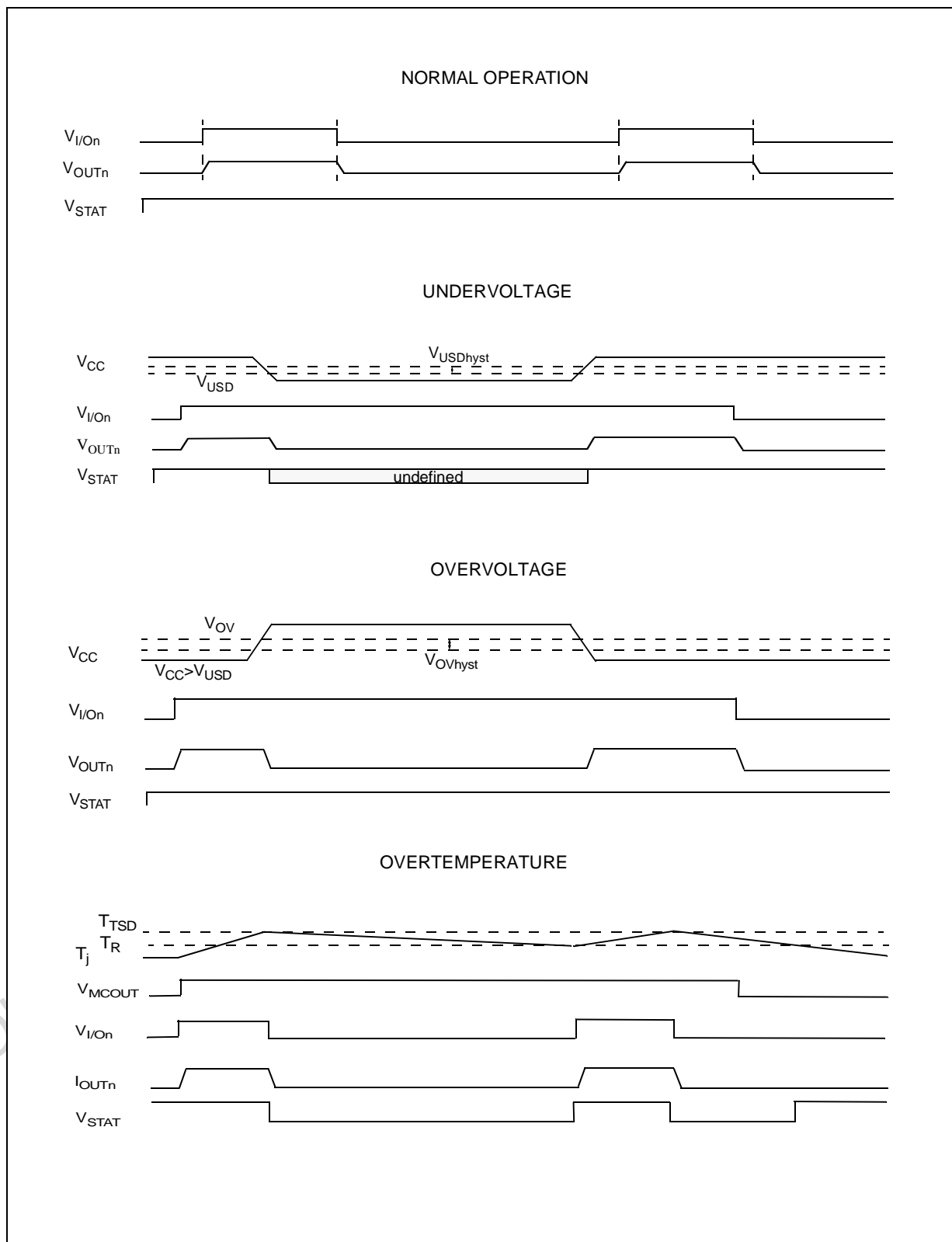
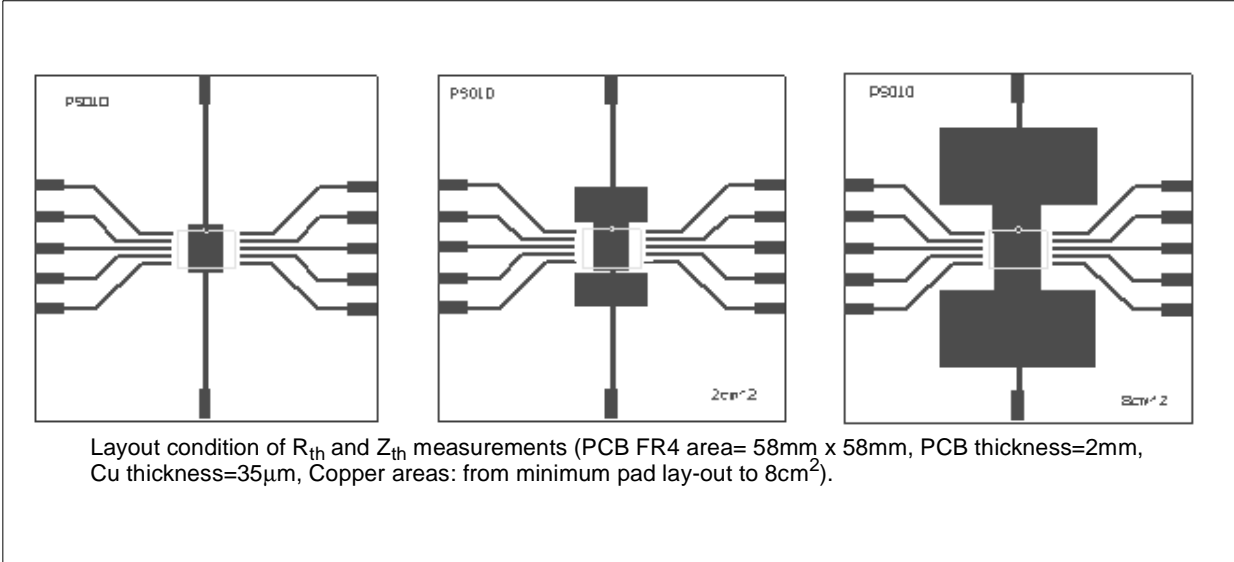

Figure 1: Waveforms



**PowerSO-10™ THERMAL DATA**

**PowerSO-10™ PC Board**



**$R_{thj-amb}$  Vs PCB copper area in open box free air condition**

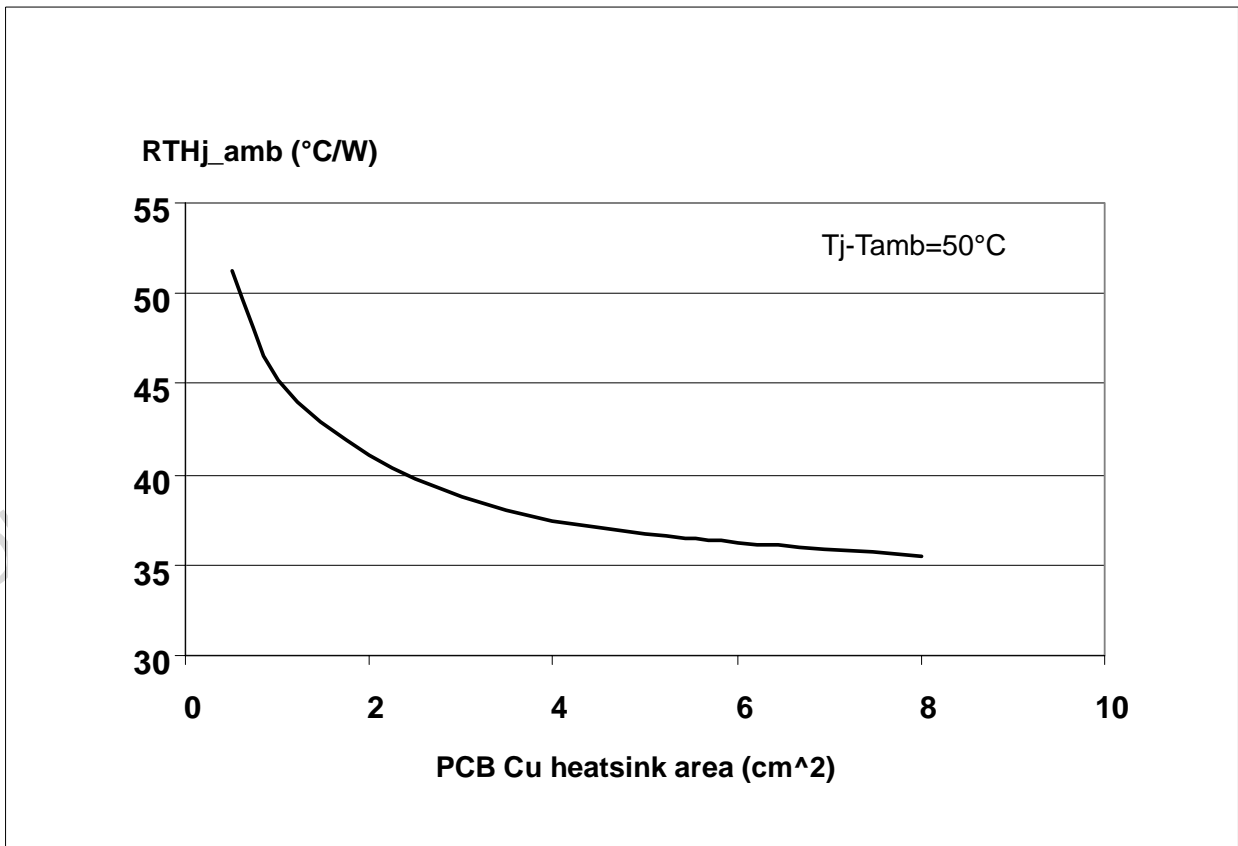

## SO-20 MECHANICAL DATA

DIM.	mm.			inch		
	MIN.	TYP.	MAX.	MIN.	TYP.	MAX.
A			2.65			0.104
a1	0.10		0.20	0.004		0.007
a2			2.45			0.096
b	0.35		0.49	0.013		0.019
b1	0.23		0.32	0.009		0.012
C		0.50			0.020	
c1	45° (typ.)					
D	12.60		13.00	0.496		0.512
E	10.00		10.65	0.393		0.419
e		1.27			0.050	
F	7.40		7.60	0.291		0.299
L	0.50		1.27	0.19		0.050
M			0.75			0.029
S	8° (max.)					

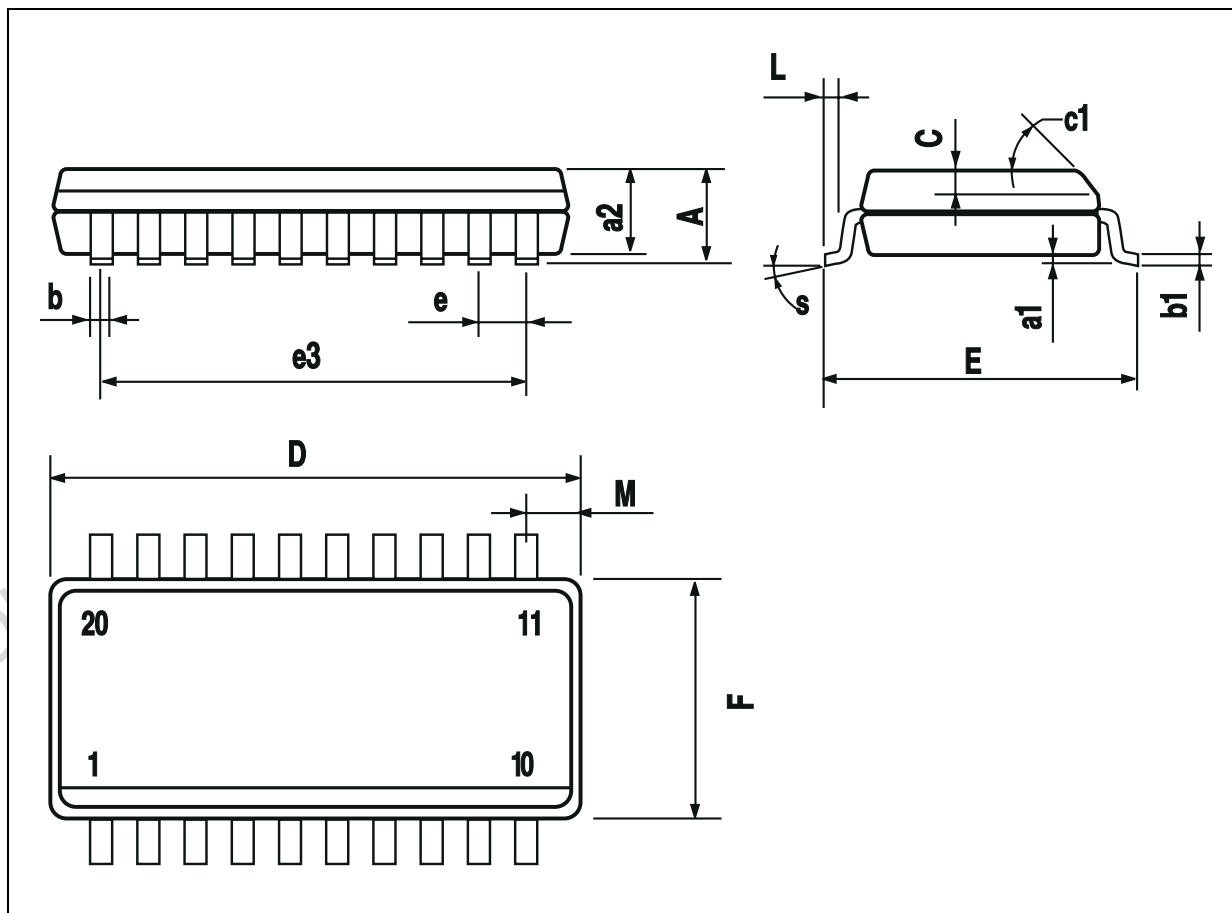



**PowerSO-10™ MECHANICAL DATA**

DIM.	mm.			inch		
	MIN.	TYP	MAX.	MIN.	TYP.	MAX.
A	3.35		3.65	0.132		0.144
A (*)	3.4		3.6	0.134		0.142
A1	0.00		0.10	0.000		0.004
B	0.40		0.60	0.016		0.024
B (*)	0.37		0.53	0.014		0.021
C	0.35		0.55	0.013		0.022
C (*)	0.23		0.32	0.009		0.0126
D	9.40		9.60	0.370		0.378
D1	7.40		7.60	0.291		0.300
E	9.30		9.50	0.366		0.374
E2	7.20		7.60	0.283		300
E2 (*)	7.30		7.50	0.287		0.295
E4	5.90		6.10	0.232		0.240
E4 (*)	5.90		6.30	0.232		0.248
e		1.27			0.050	
F	1.25		1.35	0.049		0.053
F (*)	1.20		1.40	0.047		0.055
H	13.80		14.40	0.543		0.567
H (*)	13.85		14.35	0.545		0.565
h		0.50			0.002	
L	1.20		1.80	0.047		0.070
L (*)	0.80		1.10	0.031		0.043
α	0°		8°	0°		8°
α (*)	2°		8°	2°		8°

(\*) Muar only POA P013P

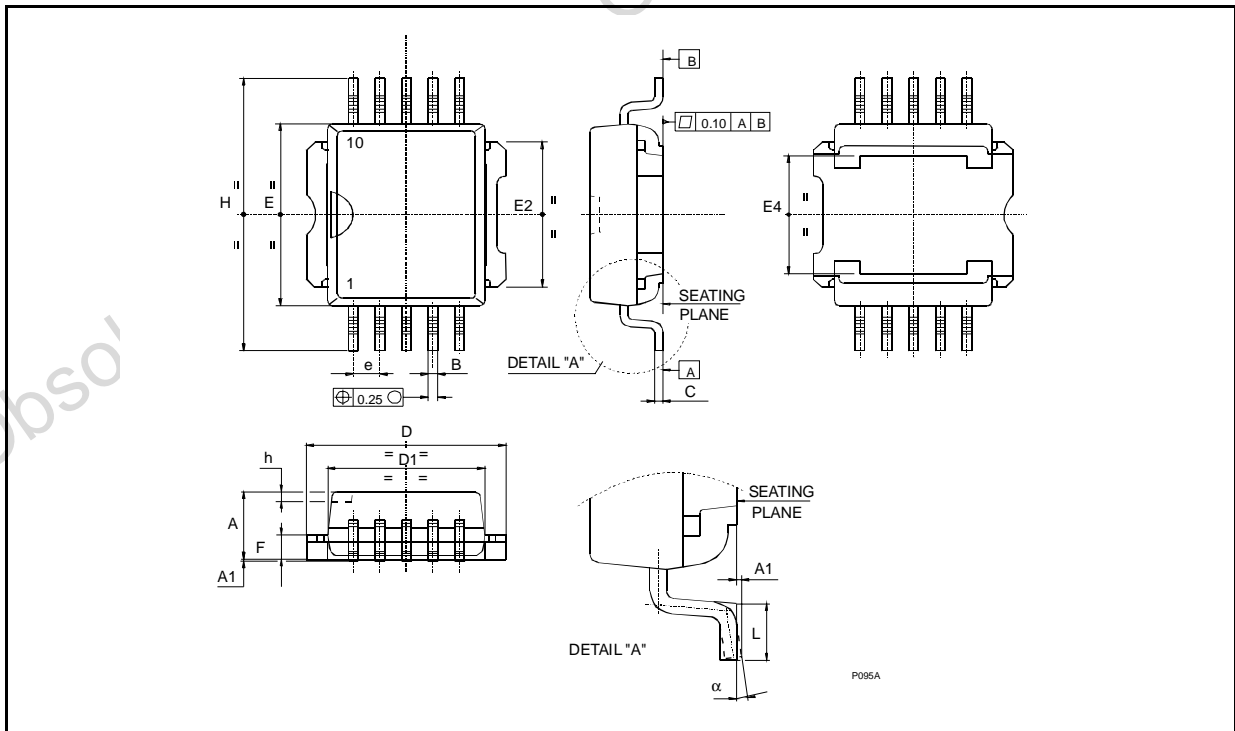

**PowerSO-10™ SUGGESTED PAD LAYOUT**

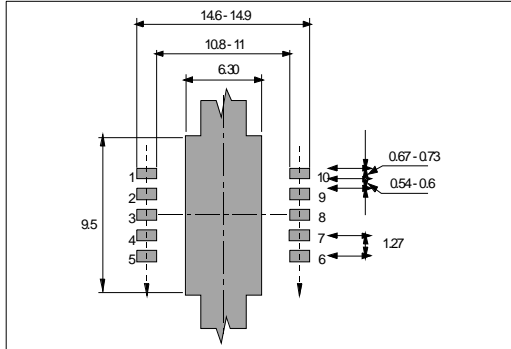

**TUBE SHIPMENT (no suffix)**

	Base Q.ty	Bulk Q.ty	Tube length (± 0.5)	A	B	C (± 0.1)
<b>Casablanca</b>	50	1000	532	10.4	16.4	0.8
<b>Muar</b>	50	1000	532	4.9	17.2	0.8

All dimensions are in mm.

**TAPE AND REEL SHIPMENT (suffix "13TR")**

**REEL DIMENSIONS**

Base Q.ty	600
Bulk Q.ty	600
A (max)	330
B (min)	1.5
C (± 0.2)	13
F	20.2
G (+ 2 / -0)	24.4
N (min)	60
T (max)	30.4

All dimensions are in mm.

**TAPE DIMENSIONS**  
According to Electronic Industries Association (EIA) Standard 481 rev. A, Feb. 1986

Tape width	W	24
Tape Hole Spacing	P0 (± 0.1)	4
Component Spacing	P	24
Hole Diameter	D (± 0.1/-0)	1.5
Hole Diameter	D1 (min)	1.5
Hole Position	F (± 0.05)	11.5
Compartment Depth	K (max)	6.5
Hole Spacing	P1 (± 0.1)	2

All dimensions are in mm.

**SO-20 TUBE SHIPMENT (no suffix)**

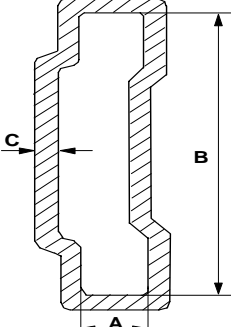

<b>Base Q.ty</b>	40
<b>Bulk Q.ty</b>	800
<b>Tube length (<math>\pm 0.5</math>)</b>	532
<b>A</b>	3.5
<b>B</b>	13.8
<b>C (<math>\pm 0.1</math>)</b>	0.6

All dimensions are in mm.

**TAPE AND REEL SHIPMENT (suffix "13TR")**

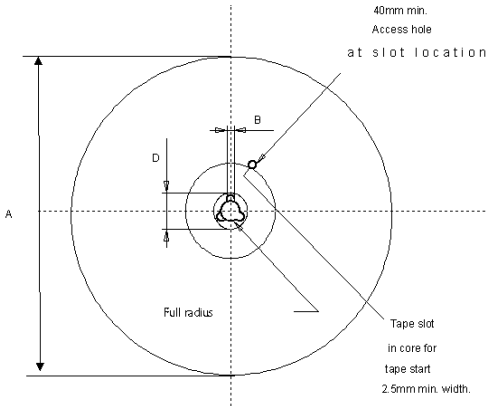

40mm min. Access hole at slot location

Full radius

Tape slot in core for tape start 2.5mm min. width.

**REEL DIMENSIONS**

<b>Base Q.ty</b>	1000
<b>Bulk Q.ty</b>	1000
<b>A (max)</b>	330
<b>B (min)</b>	1.5
<b>C (<math>\pm 0.2</math>)</b>	13
<b>F</b>	20.2
<b>G (+ 2 / -0)</b>	24.4
<b>N (min)</b>	60
<b>T (max)</b>	30.4

**TAPE DIMENSIONS**  
According to Electronic Industries Association (EIA) Standard 481 rev. A, Feb 1986

<b>Tape width</b>	<b>W</b>	24
<b>Tape Hole Spacing</b>	<b>P0 (<math>\pm 0.1</math>)</b>	4
<b>Component Spacing</b>	<b>P</b>	12
<b>Hole Diameter</b>	<b>D (<math>\pm 0.1/-0</math>)</b>	1.5
<b>Hole Diameter</b>	<b>D1 (min)</b>	1.5
<b>Hole Position</b>	<b>F (<math>\pm 0.05</math>)</b>	11.5
<b>Compartment Depth</b>	<b>K (max)</b>	6.5
<b>Hole Spacing</b>	<b>P1 (<math>\pm 0.1</math>)</b>	2

All dimensions are in mm.

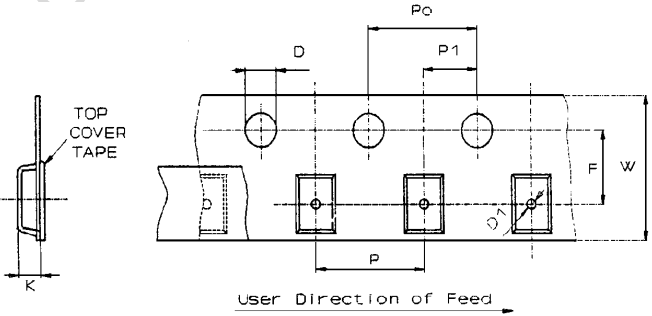

user Direction of Feed

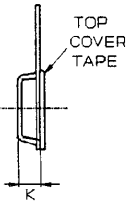
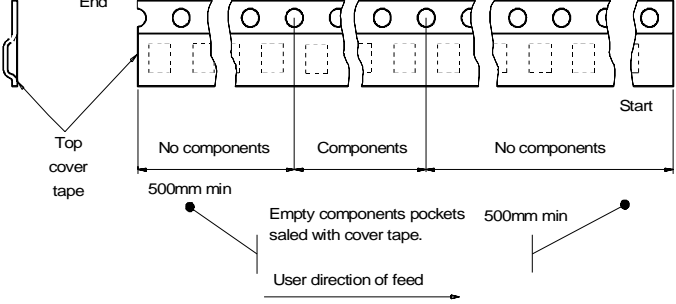
Empty components pockets sealed with cover tape.

User direction of feed

**REVISION HISTORY**

Date	Revision	Description of Changes
Jul 2004	1	<ul style="list-style-type: none"><li>- Minor changes.</li><li>- Order Codes table insertion (page 1).</li><li>- Current and voltage convention update (page 2).</li><li>- "Configuration diagram (top view) &amp; suggested connections for unused and n.c. pins" insertion (page 2).</li><li>- 6cm<sup>2</sup> Cu condition insertion in Thermal Data table (page 3).</li><li>- V<sub>CC</sub> - OUTPUT DIODE section insertion (page 4).</li><li>- SO-20 Shipment Data insertion (page 11)</li><li>- Revision History table insertion (page12).</li><li>- Disclaimers update (page 13).</li></ul>

d

Information furnished is believed to be accurate and reliable. However, STMicroelectronics assumes no responsibility for the consequences of use of such information nor for any infringement of patents or other rights of third parties which may result from its use. No license is granted by implication or otherwise under any patent or patent rights of STMicroelectronics. Specifications mentioned in this publication are subject to change without notice. This publication supersedes and replaces all information previously supplied. STMicroelectronics products are not authorized for use as critical components in life support devices or systems without express written approval of STMicroelectronics.

The ST logo is a trademark of STMicroelectronics.  
All other names are the property of their respective owners

© 2004 STMicroelectronics - Printed in ITALY- All Rights Reserved.

**STMicroelectronics GROUP OF COMPANIES**

Australia - Belgium - Brazil - Canada - China - Czech Republic - Finland - France - Germany - Hong Kong - India - Israel - Italy - Japan -  
Malaysia - Malta - Morocco - Singapore - Spain - Sweden - Switzerland - United Kingdom - United States  
<http://www.st.com>

## X-ON Electronics

Largest Supplier of Electrical and Electronic Components

*Click to view similar products for [Gate Drivers](#) category:*

*Click to view products by [STMicroelectronics](#) manufacturer:*

Other Similar products are found below :

[00053P0231](#) [8967380000](#) [56956](#) [CR7E-30DB-3.96E\(72\)](#) [57.404.7355.5](#) [LT4936](#) [57.904.0755.0](#) [5803-0901](#) [58410](#) [5882900001](#) [00600P0005](#)  
[00-9050-LRPP](#) [00-9090-RDPP](#) [5951900000](#) [01-1003W-10/32-15](#) [LTLA6E-1S-WH-RC-FN12VXCR1](#) [0131700000](#) [00-2240](#) [LTP70N06](#)  
[LVP640](#) [0158-624-00](#) [5J0-1000LG-SIL](#) [020017-13](#) [LY1D-2-5S-AC120](#) [LY2-0-US-AC120](#) [LY2-US-AC240](#) [LY3-UA-DC24](#) [00-5150](#)  
[00576P0020](#) [00600P0010](#) [LZNQ2M-US-DC5](#) [LZNQ2-US-DC12](#) [LZP40N10](#) [00-8196-RDPP](#) [00-8274-RDPP](#) [00-8275-RDNP](#) [00-8609-](#)  
[RDPP](#) [00-8722-RDPP](#) [00-8728-WHPP](#) [00-8869-RDPP](#) [00-9051-RDPP](#) [00-9091-LRPP](#) [00-9291-RDPP](#) [0207100000](#) [0207400000](#) [60100564](#)  
[01312](#) [0134220000](#) [6035](#) [M15730061](#)