

0.8 A sensitive gate SCR thyristor in SOT23-3L

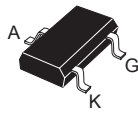

SOT23-3L

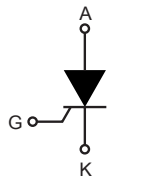

Features

- On-state rms current, 0.8 A sensitive
- Repetitive peak off-state voltage, 600 V
- Non-repetitive surge peak off-state voltage, 750 V
- Narrow sensitive gate current range [30 to 150] μA
- Compact SOT23-3L package:
 - Creepage distance of 1.1 mm
 - 9 mm² footprint

Applications

- Ground-fault circuit interrupter (GFI)
- Arc-fault circuit interrupter (AFCI)
- Overvoltage crowbar protection in power supplies
- Capacitive ignition circuits
- Low consumption triggering switches

Description

Thanks to highly sensitive triggering levels, X0115ML SCR thyristor is suitable for all applications where available gate current is limited. The X0115ML offers a high blocking voltage of 600 V, and a surge peak voltage of 750 V, ideal for applications like ground fault circuit interrupter (GFCI) and arc fault circuit interrupters (AFCI).

The SOT23-3L package provides the smallest SCR footprint while keeping 1.1 mm creepage distance, guaranteeing 120 V functional insulation (UL-840) at level 2 pollution degree without extra certification.

Product status link	
X0115ML	
Product summary	
$I_{T(RMS)}$	0.8 A
V_{DRM}/V_{RRM}	600 V
V_{DSM}/V_{RSM}	750 V
I_{GT}	[30-150] μA

1 Characteristics

Table 1. Absolute maximum ratings (limiting values)

Symbol	Parameters		Value	Unit	
$I_{T(RMS)}$	On-state RMS current (180° conduction angle)		0.8	A	
$I_{T(AV)}$	Average on-state current (180° conduction angle)				
I_{TSM}	Non repetitive surge peak on-state current (T_j initial = 25 °C)	$t_p = 8.3$ ms	7.6	A	
		$t_p = 10$ ms			
	One surge every 500 ms, 50 surges	$t_p = 8.3$ ms	$T_{AMB} = 105$ °C		5
I^2t	I^2t value for fusing	$t_p = 10$ ms	$T_j = 25$ °C	0.25	A ² s
di/dt	Critical rate of rise of on-state current $I_G = 2 \times I_{GT}$, $t_r \leq 100$ ns	$f = 60$ Hz	$T_j = 25$ °C	75	A/ μ s
V_{DRM} / V_{RRM}	Repetitive peak off-state voltage		$T_j = 125$ °C	600	V
V_{DSM} / V_{RSM}	Non repetitive surge peak off-state voltage	$t_p = 10$ ms	$T_j = 25$ °C	750	V
I_{GM}	Peak forward gate current	$t_p = 20$ μ s	$T_j = 125$ °C	1.2	A
$P_{G(AV)}$	Average gate power dissipation		$T_j = 125$ °C	0.2	W
T_{stg}	Storage junction temperature range			-40 to +150	°C
T_j	Operating junction temperature range			-40 to +125	°C

Table 2. Electrical characteristics ($T_j = 25$ °C, unless otherwise specified)

Symbol	Parameters	Value		Unit
		Min.	Max.	
I_{GT}	$V_D = 12$ V, $R_L = 33$ Ω	30	150	μ A
V_{GT}		0.8		V
V_{GD}	$V_D = V_{DRM}$, $R_L = 3.3$ k Ω , $R_{GK} = 1$ k Ω , $T_j = 125$ °C	0.2		V
V_{RG}	$I_{RG} = 10$ μ A	5		V
I_H	$I_T = 50$ mA, gate open, $R_{GK} = 1$ k Ω	5		mA
I_L	$I_G = 1.2 I_{GT}$, $R_{GK} = 1$ k Ω	6		mA
dV/dt	$V_D = 67\%$ V_{DRM} , gate open, $R_{GK} = 1$ k Ω , $T_j = 125$ °C	80		V/ μ s

Table 3. Static characteristics

Symbol	Test conditions		Value		Unit	
V_{TM}	$I_{TM} = 1.6$ A, $t_p = 380$ μ s	$T_j = 25$ °C	Max.	1.7	V	
V_{TO}	Threshold on-state voltage		$T_j = 125$ °C	Max.	1.06	V
R_d	Dynamic resistance		$T_j = 125$ °C	Max.	540	m Ω
I_{DRM} / I_{RRM}	$V_T = V_{DRM}$, $V_T = V_{RRM}$, $R_{GK} = 1$ k Ω	$T_j = 25$ °C	Max.	1	μ A	
		$T_j = 125$ °C		150	μ A	

Table 4. Thermal resistance

Symbol	Parameters	Value	Unit
$R_{th(j-l)}$	Junction to lead (DC)	Typ. 60	°C/W
$R_{th(j-a)}$	Junction to ambient (DC) for 5 cm ² copper surface	Typ. 400	

1.1 Characteristics (curves)

Figure 1. Maximum average power dissipation versus average on-state current

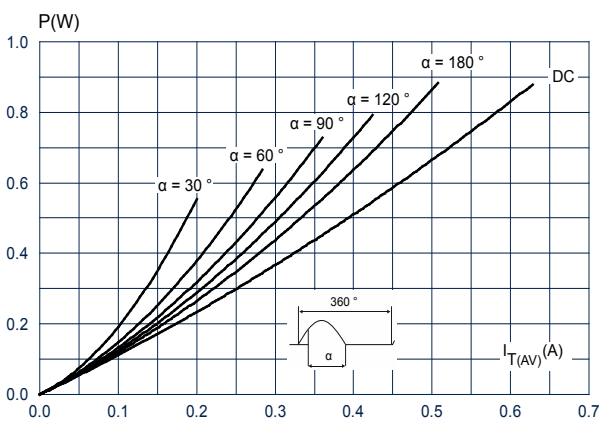

Figure 2. Average and DC on-state current versus lead temperature

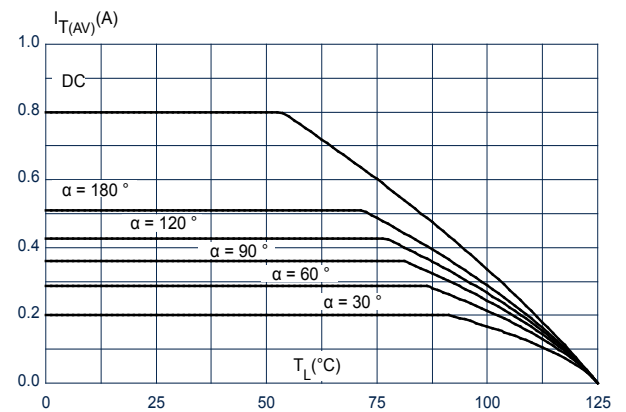

Figure 3. On-state characteristics (maximum values)

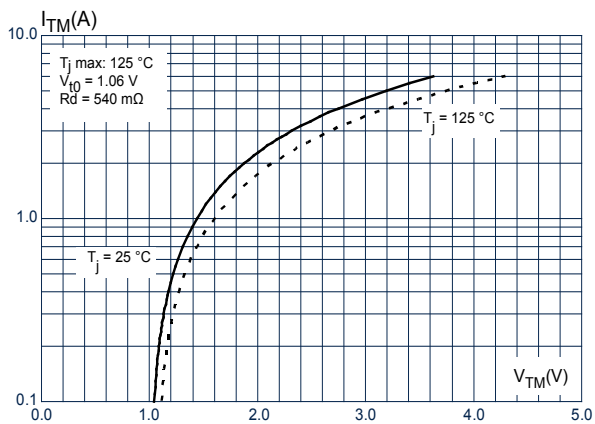

Figure 4. Average and D.C. on-state current versus ambient temperature

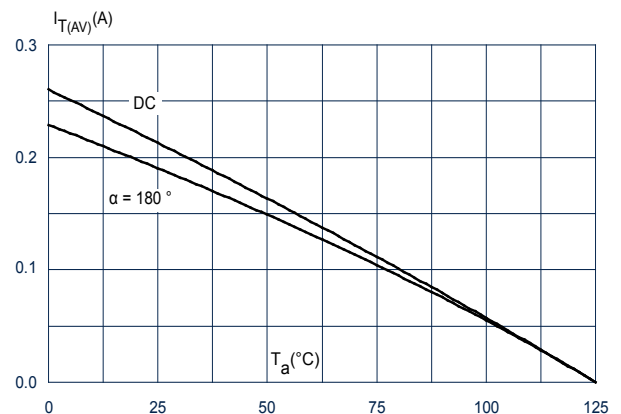

Figure 5. Relative variation of thermal impedance junction to case and junction to ambient versus pulse duration

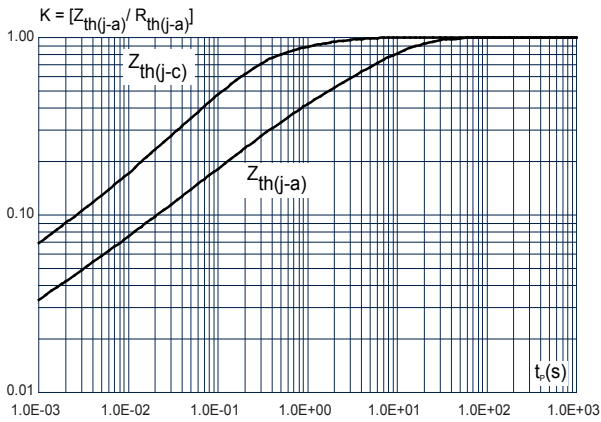

Figure 6. Surge peak on-state current versus number of cycles

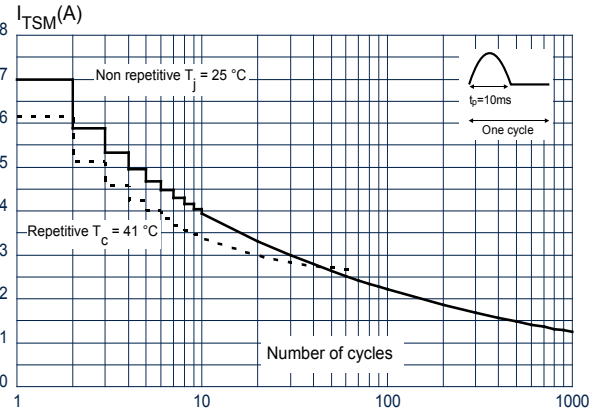

Figure 7. Non repetitive surge peak on-state current for a sinusoidal pulse with width $t_p < 10$ ms

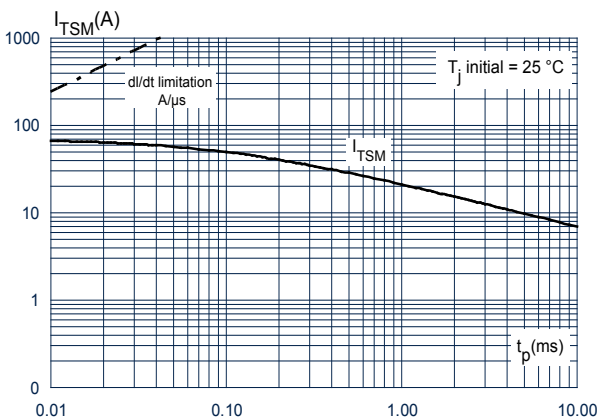

Figure 8. Relative variation of gate trigger current, holding current and latching current versus junction temperature (typical values)

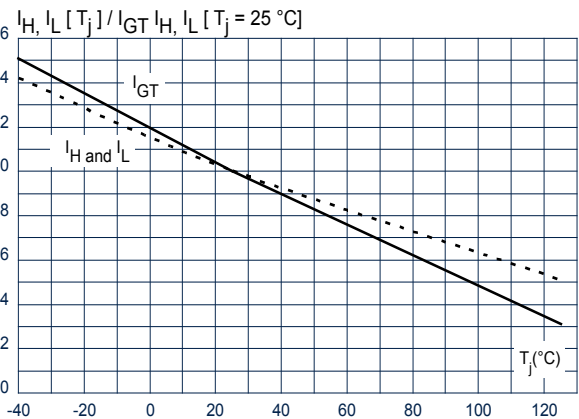

Figure 9. Relative variation of holding current versus gate-cathode resistance (typical values)

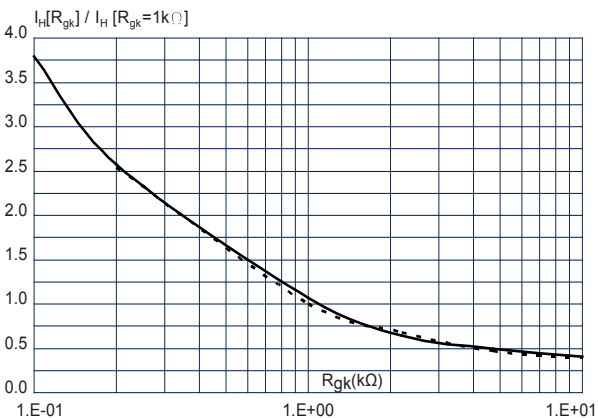

Figure 10. Relative variation of static dV/dt immunity versus junction temperature

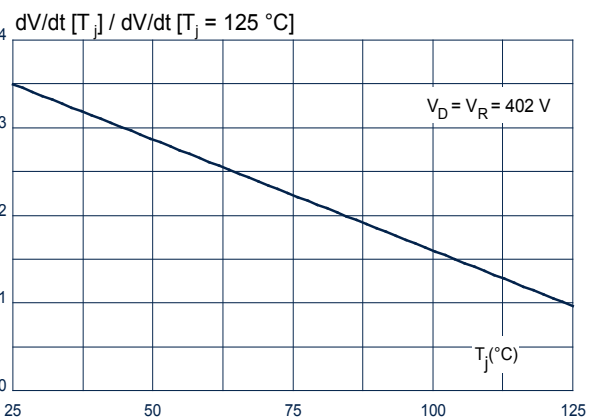

Figure 11. Relative variation of dV/dt immunity versus gate-cathode resistance (typical values)

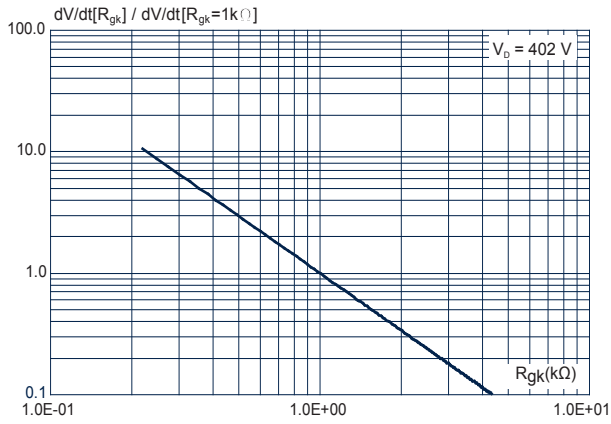

Figure 12. Relative variation of dV/dt immunity versus gate-cathode capacitance (typical values)

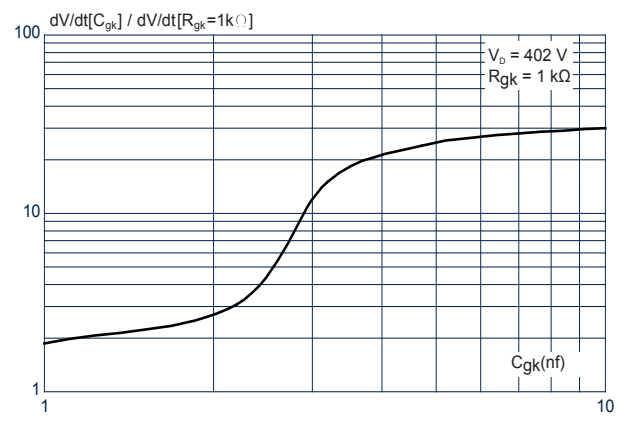
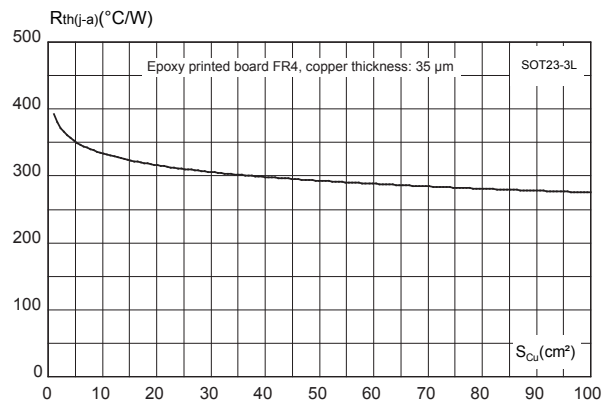

Figure 13. Typical thermal resistance junction to ambient versus copper surface under anode (epoxy FR4, $e_{Cu} = 35\mu m$, SOT-23-3L)



2 Package information

In order to meet environmental requirements, ST offers these devices in different grades of **ECOPACK** packages, depending on their level of environmental compliance. ECOPACK specifications, grade definitions and product status are available at: www.st.com. ECOPACK is an ST trademark.

2.1 SOT23-3L package information

- Lead-free package
- Halogen free molding resin
- Epoxy meets UL94, V0

Figure 14. SOT23-3L package outline

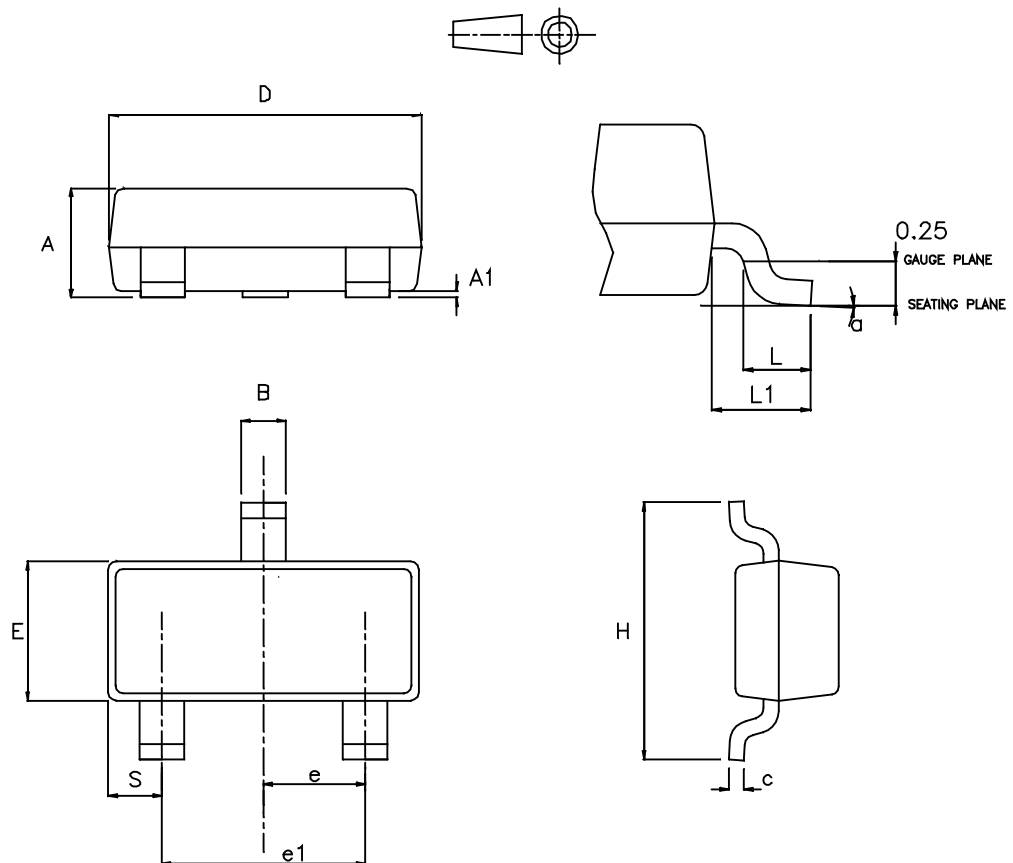
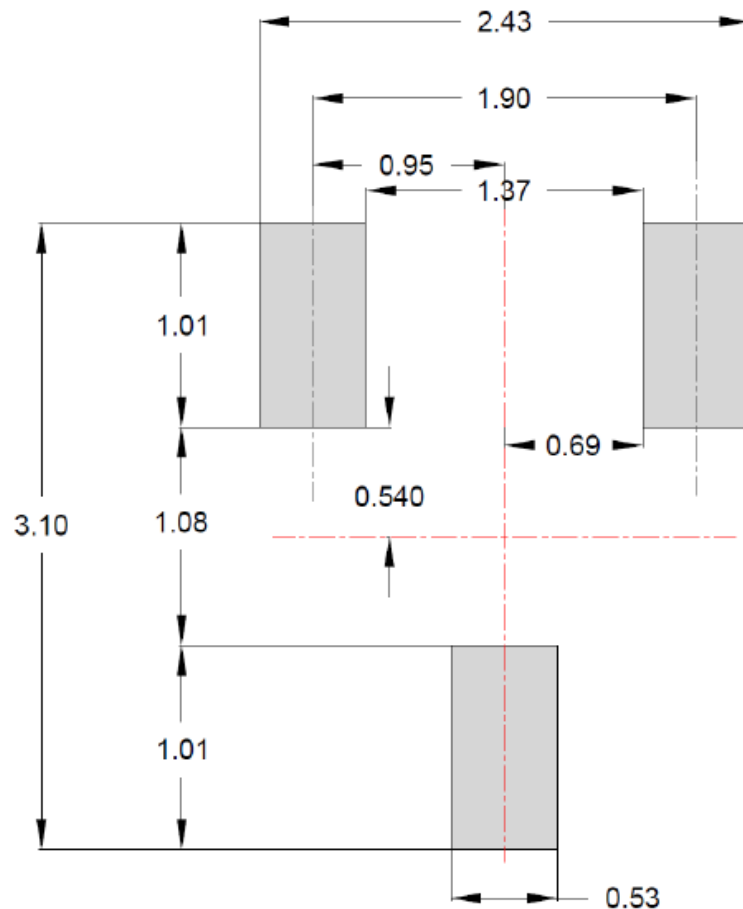

Table 5. SOT23-3L package mechanical data

Ref.	Dimensions					
	Millimeters			Inches		
	Min.	Typ.	Max.	Min.	Typ.	Max.
A	0.89		1.25	0.035		0.0493
A1	0		0.15	0		0.006
B	0.30		0.51	0.0118		0.0201
C	0.085		0.20	0.0033		0.0079
D	2.75		3.04	0.1082		0.1197
E	1.20		1.75	0.0472		0.0689
e	0.85	0.95	1.05	0.0334	0.0374	0.0414
e1	1.70	1.90	2.10	0.0669	0.0748	0.0827
H	2.10		3.00	0.0826		0.1182
L	0.25		0.61	0.0098		0.0241
L1		0.55			0.0217	
S	0.35		0.65	0.0137		0.0256
a	0°		8°	0°		8°

Figure 15. Footprint recommendations, dimensions in mm



3 Ordering information

Figure 16. Ordering information scheme

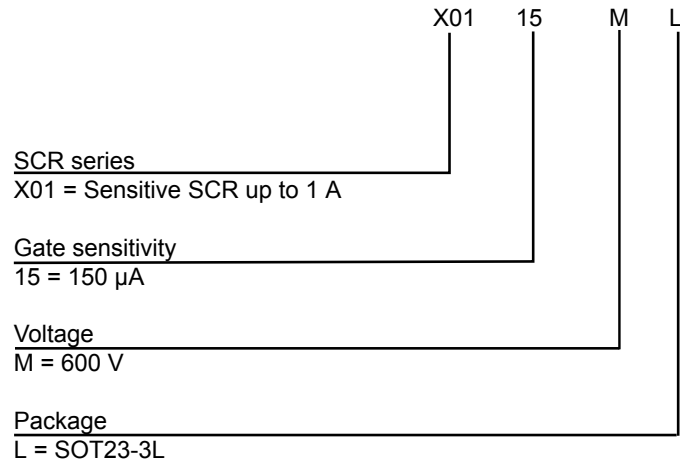

Table 6. Ordering information

Order code	Marking	Package	Weight	Base qty.	Delivery mode
X0115ML	X1M	SOT23-3L	0.01 mg	3000	Tape and reel

Revision history

Table 7. Document revision history

Date	Revision	Changes
16-Jul-2021	1	First issue.
10-Dec-2021	2	Updated Table 1 and Figure 6 .
28-Jan-2022	3	Updated Table 2 .

IMPORTANT NOTICE – PLEASE READ CAREFULLY

STMicroelectronics NV and its subsidiaries (“ST”) reserve the right to make changes, corrections, enhancements, modifications, and improvements to ST products and/or to this document at any time without notice. Purchasers should obtain the latest relevant information on ST products before placing orders. ST products are sold pursuant to ST’s terms and conditions of sale in place at the time of order acknowledgement.

Purchasers are solely responsible for the choice, selection, and use of ST products and ST assumes no liability for application assistance or the design of Purchasers’ products.

No license, express or implied, to any intellectual property right is granted by ST herein.

Resale of ST products with provisions different from the information set forth herein shall void any warranty granted by ST for such product.

ST and the ST logo are trademarks of ST. For additional information about ST trademarks, please refer to www.st.com/trademarks. All other product or service names are the property of their respective owners.

Information in this document supersedes and replaces information previously supplied in any prior versions of this document.

© 2022 STMicroelectronics – All rights reserved

X-ON Electronics

Largest Supplier of Electrical and Electronic Components

Click to view similar products for [SCRs](#) category:

Click to view products by [STMicroelectronics](#) manufacturer:

Other Similar products are found below :

[NTE5428](#) [T1500N16TOF VT](#) [T830N16TOF](#) [T880N14TOF](#) [T880N16TOF](#) [TT162N16KOF-A](#) [TT330N16AOF](#) [VS-22RIA20](#) [VS-2N685](#) [VS-80RIA120PBF](#) [BT152-400R/B](#) [T1190N16TOF VT](#) [T830N14TOF](#) [TT250N12KOF-K](#) [NTE5427](#) [VS-180RKI40](#) [T2160N28TOF VT](#) [VS-22RIA100](#) [VS-16RIA40](#) [GA301A](#) [2N1776A](#) [NTE5481](#) [NTE5519](#) [NTE5553](#) [NTE5570](#) [NTE5576](#) [NTE5584](#) [NTE5589](#) [NTE5592](#) [NTE6418](#) [NTE6419](#) [T3160N16TOF VT](#) [T1500N18TOF VT](#) [T3160N18TOF VT](#) [VS-82RIA120](#) [TN1610H-6I](#) [K1010MA650](#) [BT151-500RT,127](#) [BTW69-800RG](#) [T3035H-800B](#) [T1635H-800B](#) [TS420-600T-JSM](#) [BTB12-800CW](#) [BT136](#) [BTA41-800B](#) [BTW69-1200B](#) [C106M](#) [BTA12-800CW](#) [BTB08-800CW](#) [BTB16-600B](#)