

## Digital MEMS microphones expansion board based on MP34DT01-M for STM32 Nucleo

Data brief



### Description

The X-NUCLEO-CCA02M1 is an evaluation board based on digital MEMS microphones. It is compatible with the ST morpho connector layout, and is designed around STMicroelectronics MP34DT01-M digital microphones. It has two microphones soldered onto the board and is compatible with digital microphone coupon boards such as STEVAL-MKI129Vx and STEVAL-MKI155Vx.

The X-NUCLEO-CCA02M1 allows synchronized acquisition and streaming of up to 4 microphones through I<sup>2</sup>S, SPI or DFSDM peripherals. It represents a quick and easy solution for the development of microphone-based applications as well as a starting point for audio algorithm implementation.

### Features

- 2 on-board MP34DT01-M digital MEMS microphones
- 6 slots to plug in digital microphone coupon boards such as STEVAL-MKI129Vx and STEVAL-MKI155Vx
- Synchronized acquisition and streaming of up to 4 microphones
- Free comprehensive development firmware library and audio capture plus USB streaming sample application which is compatible with STM32Cube firmware
- Compatible with STM32 Nucleo boards
- Equipped with ST morpho connector (upwards and downwards)
- Equipped with Arduino UNO R3 connector (upwards) to allow multiple boards
- RoHS compliant



# 1 Schematic diagrams

Figure 1: X-NUCLEO-CCA02M1 circuit schematic (Part 1)

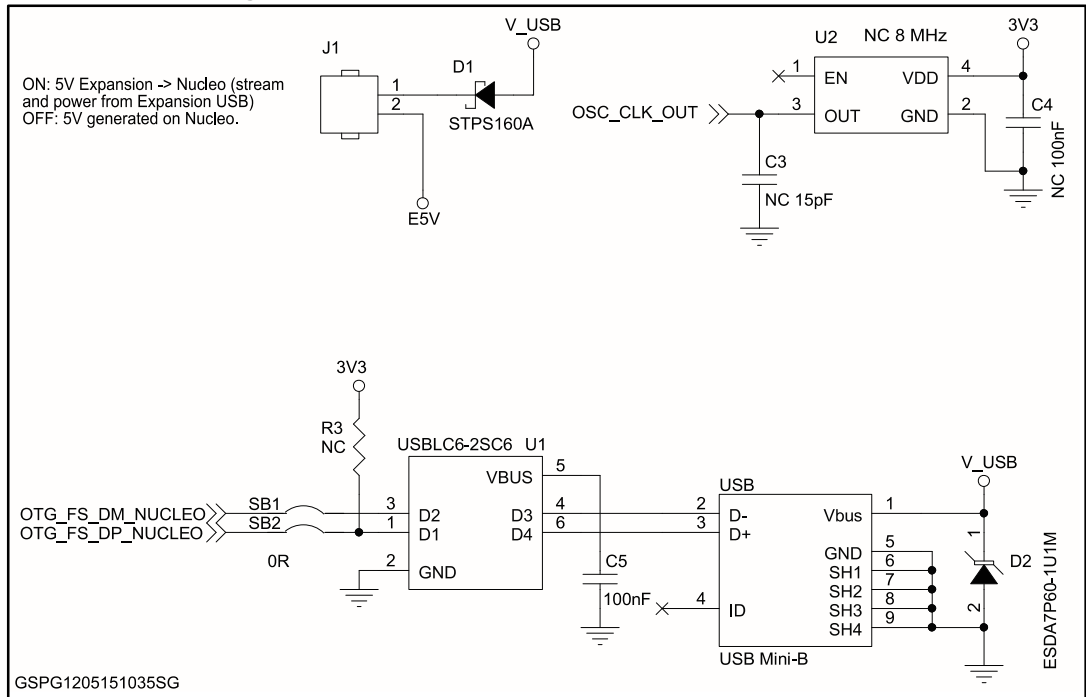

Figure 2: X-NUCLEO-CCA02M1 circuit schematic (Part 2)

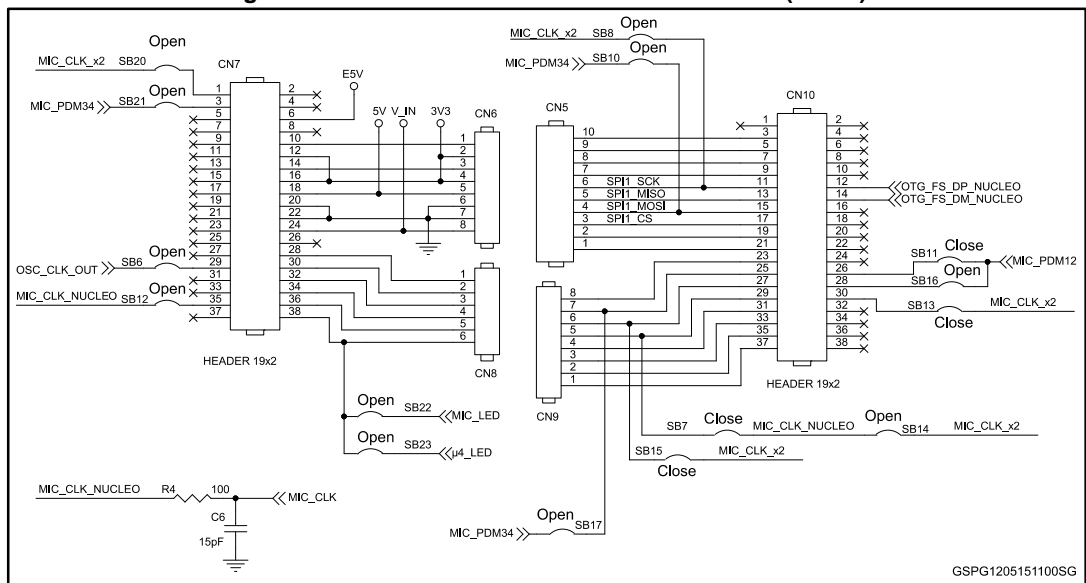

Figure 3: X-NUCLEO-CCA02M1 circuit schematic (Part 3)

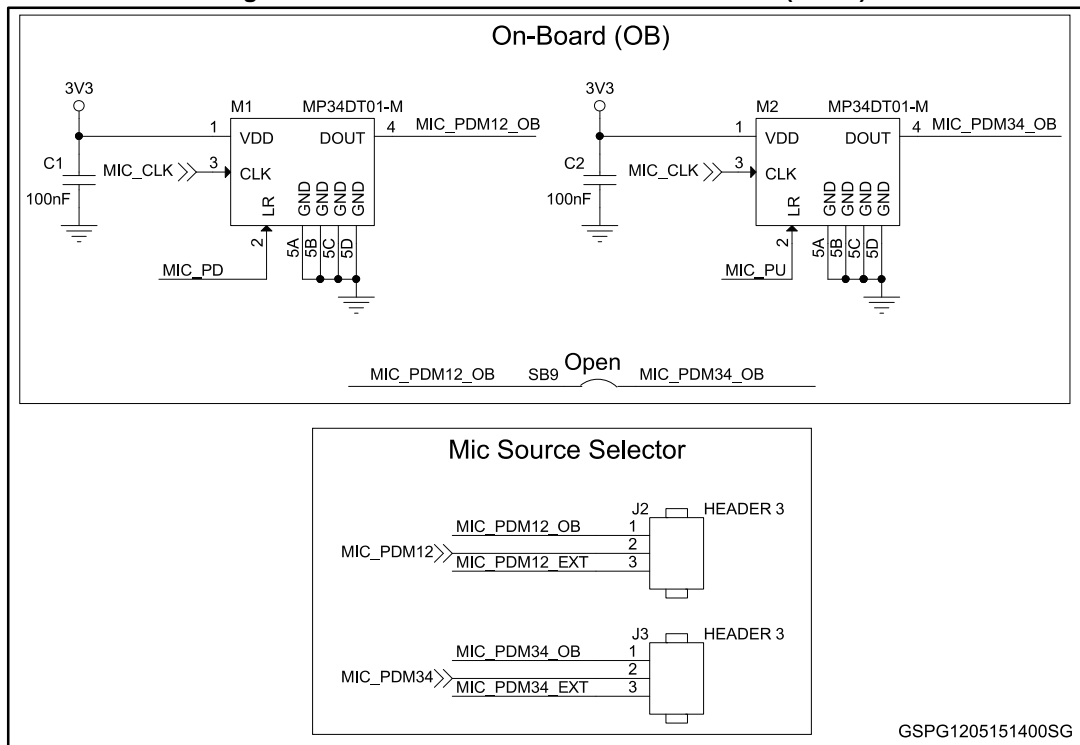
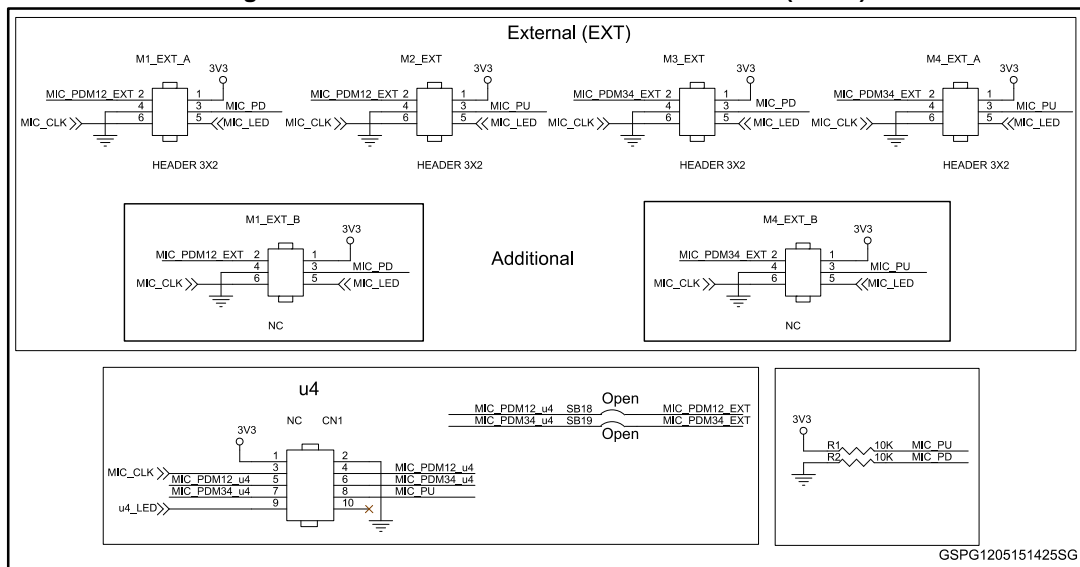

Figure 4: X-NUCLEO-CCA02M1 circuit schematic (Part 4)



## 2 Revision history

Table 1: Document revision history

Date	Version	Changes
13-May-2015	1	Initial release.
28-Jan-2016	2	Updated cover page <a href="#">Section "Description"</a>

**IMPORTANT NOTICE – PLEASE READ CAREFULLY**

STMicroelectronics NV and its subsidiaries ("ST") reserve the right to make changes, corrections, enhancements, modifications, and improvements to ST products and/or to this document at any time without notice. Purchasers should obtain the latest relevant information on ST products before placing orders. ST products are sold pursuant to ST's terms and conditions of sale in place at the time of order acknowledgement.

Purchasers are solely responsible for the choice, selection, and use of ST products and ST assumes no liability for application assistance or the design of Purchasers' products.

No license, express or implied, to any intellectual property right is granted by ST herein.

Resale of ST products with provisions different from the information set forth herein shall void any warranty granted by ST for such product.

ST and the ST logo are trademarks of ST. All other product or service names are the property of their respective owners.

Information in this document supersedes and replaces information previously supplied in any prior versions of this document.

© 2016 STMicroelectronics – All rights reserved

## X-ON Electronics

Largest Supplier of Electrical and Electronic Components

*Click to view similar products for [Audio IC Development Tools](#) category:*

*Click to view products by [STMicroelectronics](#) manufacturer:*

Other Similar products are found below :

[1580/5171-DEMO](#) [LM4906MMBD](#) [LM4935RLEVAL](#) [LME49710NABD](#) [LME49740MABD](#) [LME49740NABD](#) [LME49860MABD](#)  
[LME49870MABD](#) [EVAL-AD1940AZ](#) [EVAL-ADAU1401AEBZ](#) [SRC4382EVM-PDK](#) [TLV320AIC36EVM-K](#) [TPA5052EVM](#)  
[TPA6136A2YFFEVM](#) [LM4562HABD](#) [LM4906LDBD](#) [LM4923LQBD](#) [LM4992SDBD](#) [LME49710MABD](#) [LME49713MABD](#)  
[LME49860NABD](#) [MAX98300EVKIT+WLP](#) [MAX9738EVKIT+](#) [MAX98358EVSYS#WLP](#) [MAX9723DEVKIT+](#) [EVAL-ADAV803EBZ](#)  
[MAX9890EVKIT+](#) [LM4809MBD](#) [LM4674TLBD](#) [CDBWM8725-M-1](#) [CDBWM8533-M-1](#) [EV\\_ICS-40740-FX](#) [SDCK3](#) [PIM524](#)  
[MAX9723DEVCMODU+](#) [DEV-17737](#) [EVALAHNBIM69D130V01TOBO1](#) [1063](#) [TAS5756MDCAEVM](#) [TLV320ADC3101EVM-K](#)  
[TLV320AIC3007EVM-K](#) [TLV320AIC3105EVM-K](#) [TLV320AIC3253EVM-K](#) [TLV320DAC32EVM-PDK](#) [TPA2016D2EVM](#)  
[TPA2035D1EVM](#) [TPA2051D3YFFEVM](#) [TPA3107D2EVM](#) [TPA6120A2EVM](#) [TPA6132A2EVM2](#)