

Motor control connector expansion board for STM32 Nucleo

Data brief



Description

The X-NUCLEO-IHM09M1 is a motor control connector expansion board for STM32 Nucleo. It provides an easy way to evaluate motor control solutions for three-phase motors by adapting the STM32 Nucleo board with an external ST motor control power board, thanks to ST morpho and motor control connector. The 34-pin motor control connector is compatible with all major ST motor control power boards, requiring an external digital section (MCU) to drive a three-phase motor. The DAC connector supports user code development and testing with easy access to the MCU peripherals. An LED is available for fault condition signaling or status indication.

Features

- ST motor control connector (34 pins) compatible with major ST motor control power boards
- STM32 Nucleo support, thanks to ST morpho connectors
- Compatible with six-step and FOC motor control firmware library by ST
- Debug connector for DAC, GPIOs, etc.
- Fully populated board conception with test points
- LED for fault signaling or status indication
- Potentiometer available (i.e. for speed reference)
- RoHS compliant

1 Schematic diagram

Figure 1: X-NUCLEO-IHM09M1 schematic: PWM

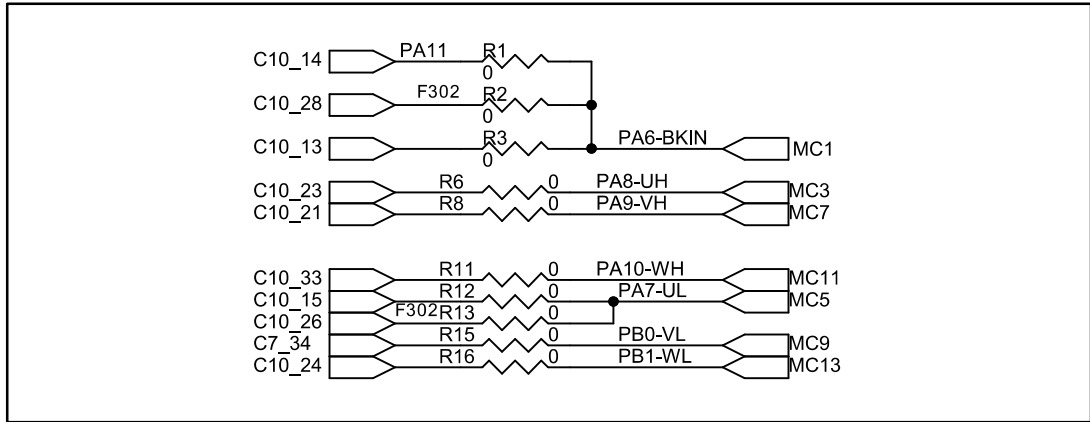

Figure 2: X-NUCLEO-IHM09M1 schematic: Hall/encoder sensor

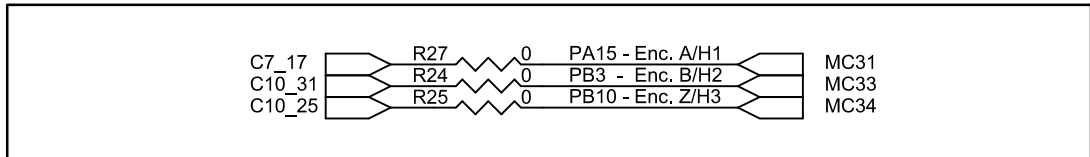

Figure 3: X-NUCLEO-IHM09M1 schematic: currents

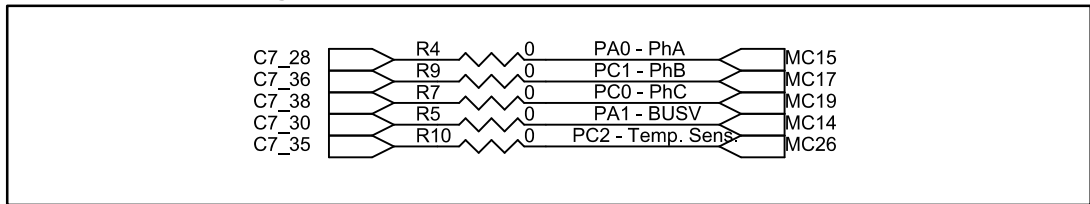

Figure 4: X-NUCLEO-IHM09M1 schematic: DAC

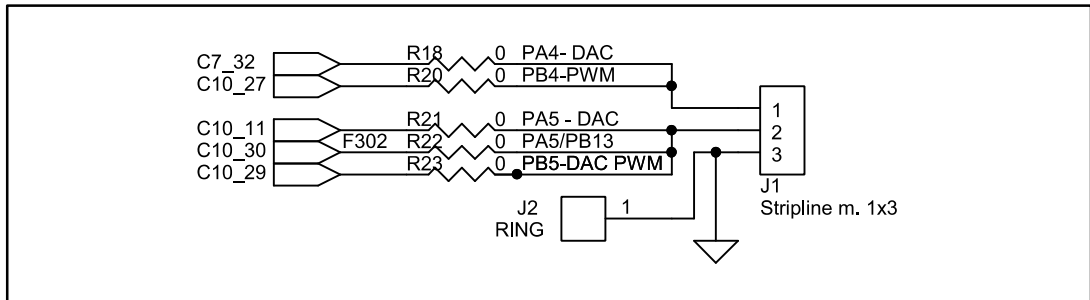

Figure 5: X-NUCLEO-IHM09M1 schematic: user interface

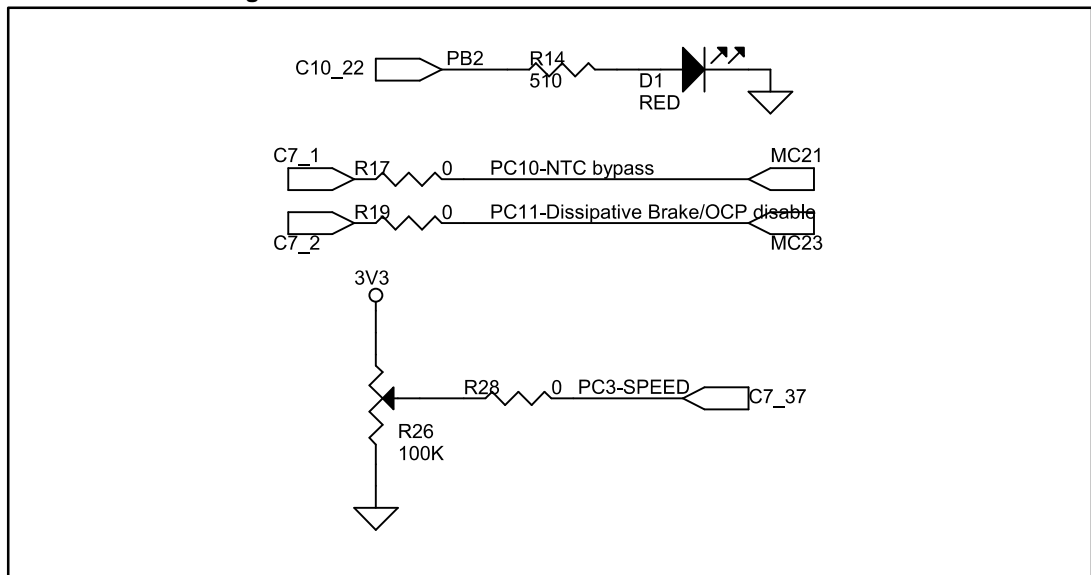

Figure 6: X-NUCLEO-IHM09M1 schematic: motor control connector

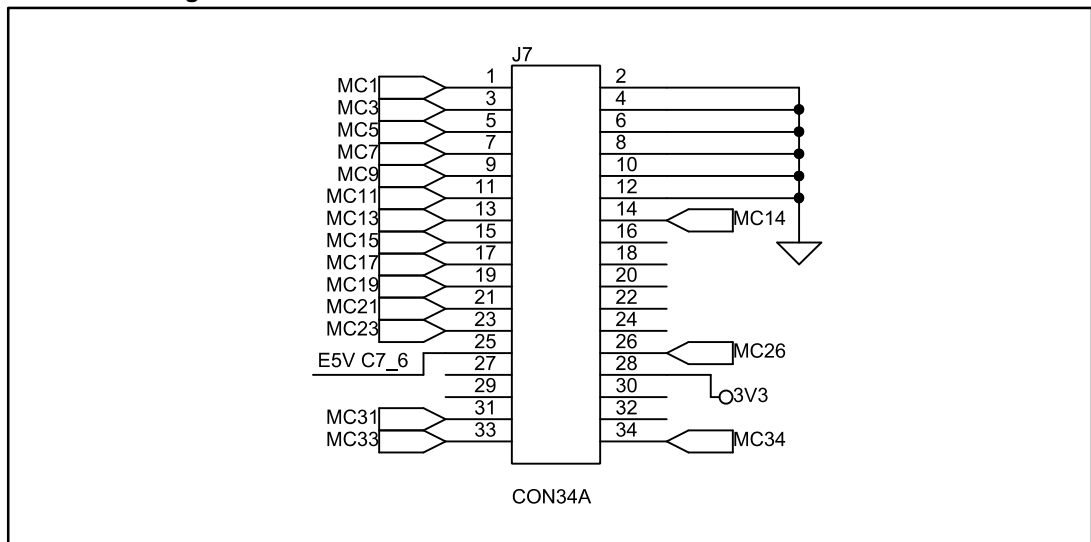
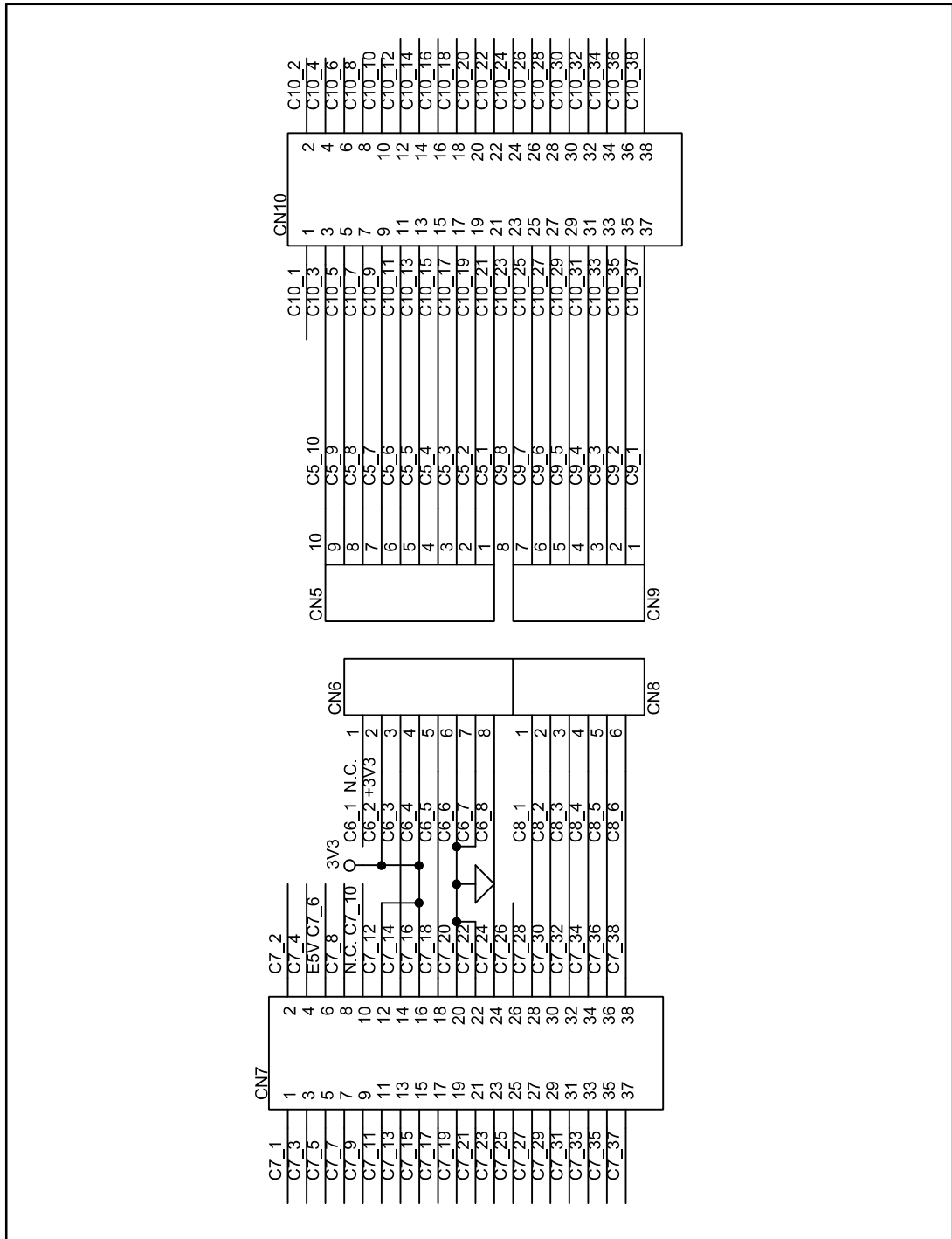

Figure 7: X-NUCLEO-IHM09M1 schematic: Arduino UNO R3/ST morpho connector



2 Revision history

Table 1: Document revision history

Date	Version	Changes
23-Oct-2015	1	Initial release.

IMPORTANT NOTICE – PLEASE READ CAREFULLY

STMicroelectronics NV and its subsidiaries ("ST") reserve the right to make changes, corrections, enhancements, modifications, and improvements to ST products and/or to this document at any time without notice. Purchasers should obtain the latest relevant information on ST products before placing orders. ST products are sold pursuant to ST's terms and conditions of sale in place at the time of order acknowledgement.

Purchasers are solely responsible for the choice, selection, and use of ST products and ST assumes no liability for application assistance or the design of Purchasers' products.

No license, express or implied, to any intellectual property right is granted by ST herein.

Resale of ST products with provisions different from the information set forth herein shall void any warranty granted by ST for such product.

ST and the ST logo are trademarks of ST. All other product or service names are the property of their respective owners.

Information in this document supersedes and replaces information previously supplied in any prior versions of this document.

© 2015 STMicroelectronics – All rights reserved

X-ON Electronics

Largest Supplier of Electrical and Electronic Components

Click to view similar products for [Power Management IC Development Tools](#) category:

Click to view products by [STMicroelectronics](#) manufacturer:

Other Similar products are found below :

[EVAL-ADM1168LQEBZ](#) [EVB-EP5348UI](#) [MIC23451-AAAYFL EV](#) [MIC5281YMME EV](#) [DA9063-EVAL](#) [ADP122-3.3-EVALZ](#) [ADP130-0.8-EVALZ](#) [ADP130-1.2-EVALZ](#) [ADP130-1.5-EVALZ](#) [ADP130-1.8-EVALZ](#) [ADP1712-3.3-EVALZ](#) [ADP1714-3.3-EVALZ](#) [ADP1715-3.3-EVALZ](#) [ADP1716-2.5-EVALZ](#) [ADP1740-1.5-EVALZ](#) [ADP1752-1.5-EVALZ](#) [ADP1828LC-EVALZ](#) [ADP1870-0.3-EVALZ](#) [ADP1871-0.6-EVALZ](#) [ADP1873-0.6-EVALZ](#) [ADP1874-0.3-EVALZ](#) [ADP1882-1.0-EVALZ](#) [ADP199CB-EVALZ](#) [ADP2102-1.25-EVALZ](#) [ADP2102-1.875EVALZ](#) [ADP2102-1.8-EVALZ](#) [ADP2102-2-EVALZ](#) [ADP2102-3-EVALZ](#) [ADP2102-4-EVALZ](#) [ADP2106-1.8-EVALZ](#) [ADP2147CB-110EVALZ](#) [AS3606-DB](#) [BQ24010EVM](#) [BQ24075TEVM](#) [BQ24155EVM](#) [BQ24157EVM-697](#) [BQ24160EVM-742](#) [BQ24296MEVM-655](#) [BQ25010EVM](#) [BQ3055EVM](#) [NCV891330PD50GEVB](#) [ISLUSBI2CKIT1Z](#) [LM2744EVAL](#) [LM2854EVAL](#) [LM3658SD-AEV/NOPB](#) [LM3658SDEV/NOPB](#) [LM3691TL-1.8EV/NOPB](#) [LM4510SDEV/NOPB](#) [LM5033SD-EVAL](#) [LP38512TS-1.8EV](#)