

Sub-1 GHz 868 MHz RF expansion board based on S2-LP radio for STM32 Nucleo

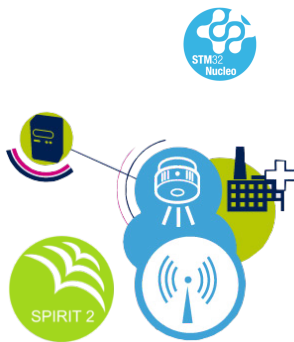
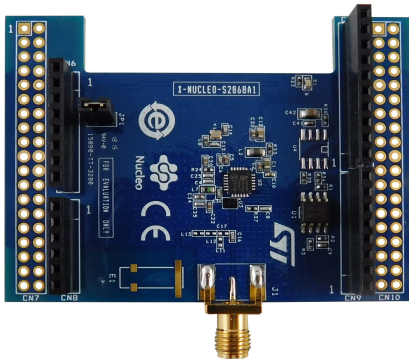

Features

- Based on [S2-LP](#) radio
- S2-LP narrow band ultra-low power sub-1 GHz transceiver tuned for 860 - 940 MHz frequency band
- Programmable RF output power up to +16 dBm
- Modulation schemes: 2-FSK, 2-GFSK, 4-FSK, 4-GFSK, OOK and ASK
- Air data rate from 0.1 to 500 kbps
- Ultra-low power consumption: 7 mA RX and 10 mA TX at +10 dBm
- IEEE 802.15.4g hardware packet support with whitening, FEC, CRC and dual SYNC word detection
- RX and TX 128 byte FIFO buffers
- Support to wireless M-Bus
- Excellent performance of receiver sensitivity (up to -130 dBm)
- Automatic acknowledgement, retransmission and timeout protocol engine
- Compatible with [STM32 Nucleo](#) boards
- Compatible with Arduino UNO R3 connectors
- Support to SMD and SMA antennas
- [BALF-SPI2-01D3](#) IPD balun for matching network and harmonics filter
- Sigfox compatible
- Sample firmware for P2P communication
- 6LoWPAN compatible thanks to [STM32Cube](#)
- RoHS compliant

Product summary	
Sub-1 GHz RF expansion board based on S2-LP radio for STM32 Nucleo	X-NUCLEO-S2868A1
Ultra-low power, high performance, sub-1 GHz transceiver	S2-LP
50 Ω nominal input/conjugate match balun to S2-LP, 868-930 MHz with integrated harmonics filter	BALF-SPI2-01D3

Description

The [X-NUCLEO-S2868A1](#) expansion board is based on the [S2-LP](#) radio and operates in the 868 MHz ISM frequency band.

The expansion board is compatible with ST morpho and Arduino UNO R3 connectors.

The X-NUCLEO-S2868A1 interfaces with the [STM32 Nucleo](#) microcontroller via SPI connections and GPIO pins. You can change some of the GPIOs by mounting or removing the resistors.

1 X-NUCLEO-S2868A1 schematic diagram

Figure 1. X-NUCLEO-S2868A1 circuit schematic

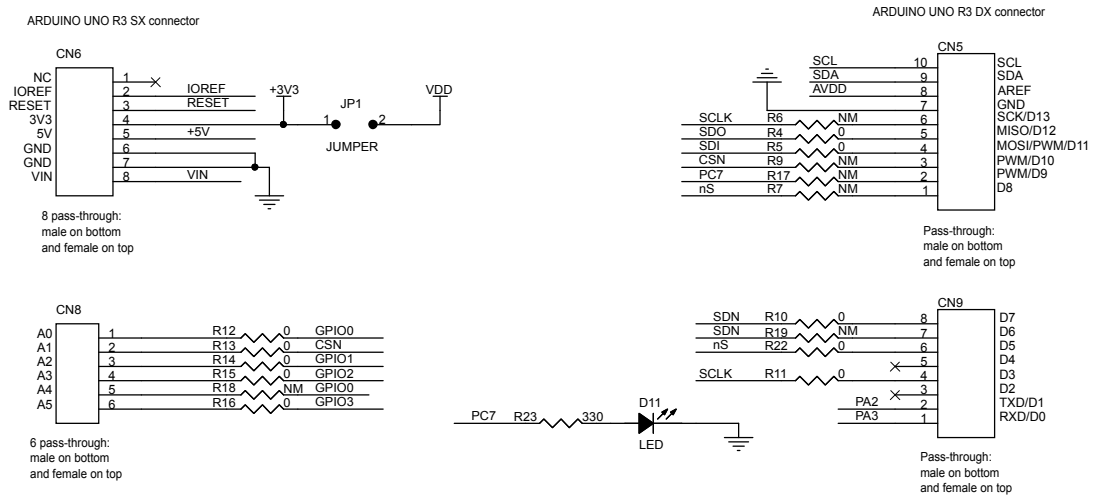
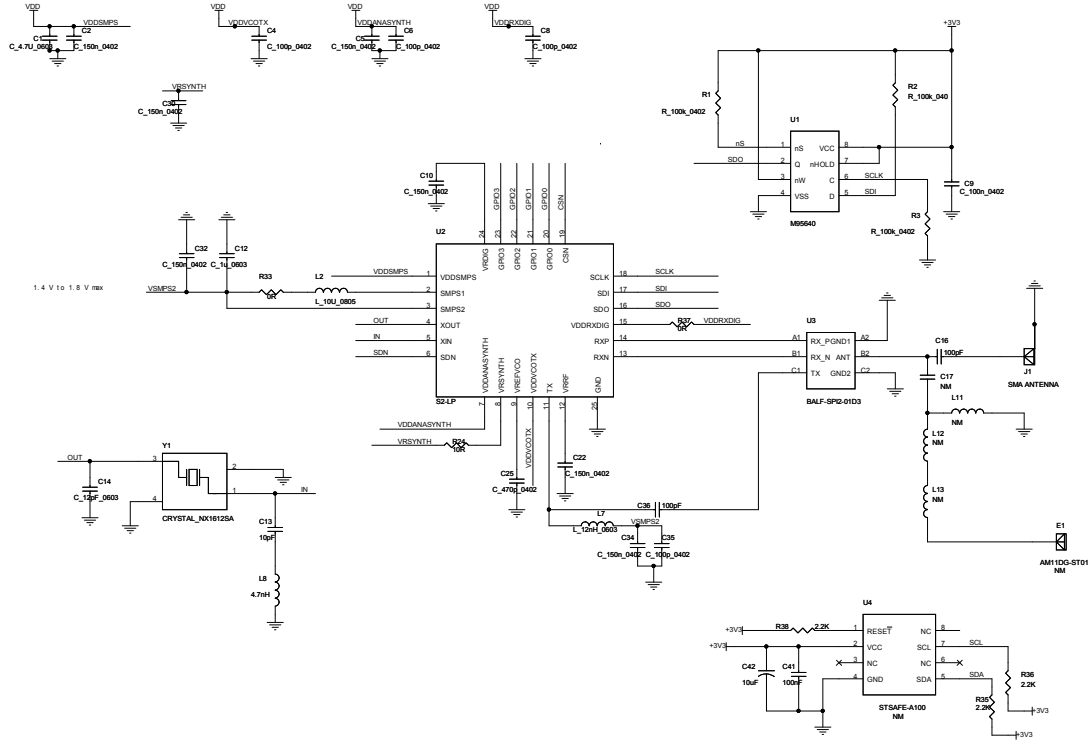
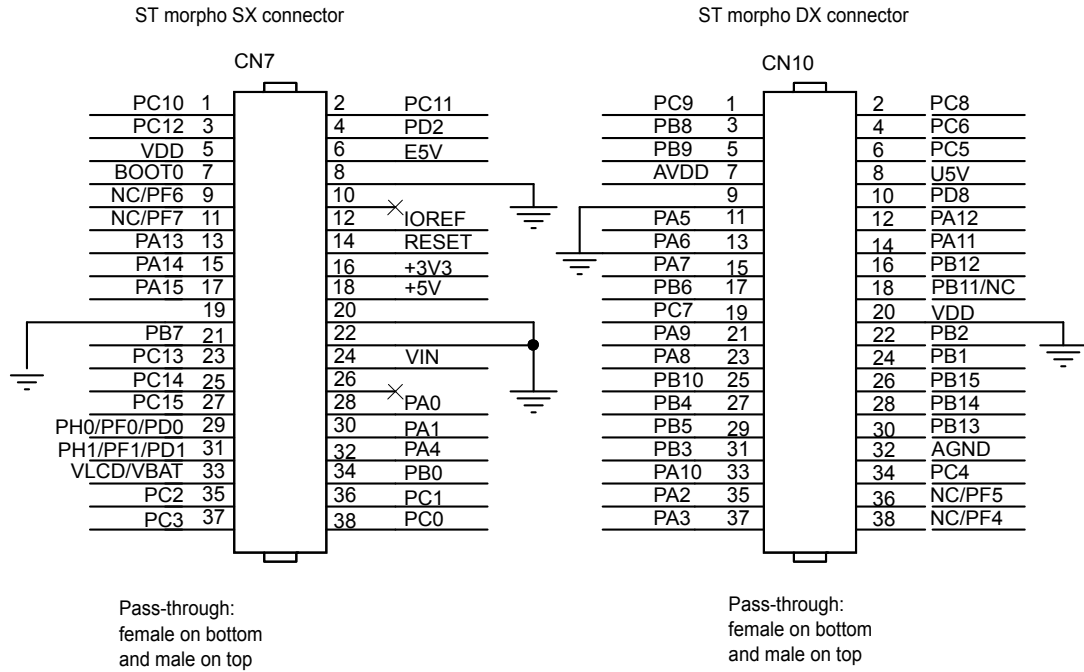

Figure 3. X-NUCLEO-S2868A1 circuit schematic - morpho connectors



Revision history

Table 1. Document revision history

Date	Version	Changes
11-May-2018	1	Initial release.

IMPORTANT NOTICE – PLEASE READ CAREFULLY

STMicroelectronics NV and its subsidiaries (“ST”) reserve the right to make changes, corrections, enhancements, modifications, and improvements to ST products and/or to this document at any time without notice. Purchasers should obtain the latest relevant information on ST products before placing orders. ST products are sold pursuant to ST’s terms and conditions of sale in place at the time of order acknowledgement.

Purchasers are solely responsible for the choice, selection, and use of ST products and ST assumes no liability for application assistance or the design of Purchasers’ products.

No license, express or implied, to any intellectual property right is granted by ST herein.

Resale of ST products with provisions different from the information set forth herein shall void any warranty granted by ST for such product.

ST and the ST logo are trademarks of ST. All other product or service names are the property of their respective owners.

Information in this document supersedes and replaces information previously supplied in any prior versions of this document.

© 2018 STMicroelectronics – All rights reserved

X-ON Electronics

Largest Supplier of Electrical and Electronic Components

Click to view similar products for [Sub-GHz Development Tools](#) category:

Click to view products by [STMicroelectronics](#) manufacturer:

Other Similar products are found below :

[EVAL-ADF7021DBJZ](#) [EVAL-ADF7021-NDBZ2](#) [EVAL-ADF7021-VDB3Z](#) [EVAL-ADF7023DB3Z](#) [MICRF219A-433 EV](#) [MICRF220-433 EV](#) [AD6679-500EBZ](#) [EVAL-ADF7901EBZ](#) [EVAL-ADF790XEBZ](#) [110976-HMC453QS16G](#) [STEVAL-IKR002V7D](#) [MAX2602EVKIT+](#) [MAX1472EVKIT-315](#) [MAX1479EVKIT-315](#) [STEVAL-IKR002V3D](#) [MAX7042EVKIT-315+](#) [MAX2902EVKIT#](#) [MAX9947EVKIT+](#) [MAX1470EVKIT-315](#) [SKY66188-11-EK1](#) [SKY66013-11-EVB](#) [EVAL-ADF7023DB5Z](#) [DRF1200/CLASS-E 1096](#) [1098](#) [MDEV-900-PRO DVK-SFUS-1-GEVK](#) [DVK-SFUS-API-1-GEVK](#) [US-SIGFOX-GEVB](#) [STEVAL-IKR002V2D](#) [107755-HMC454ST89](#) [DM182017-2](#) [110961-HMC453ST89](#) [DM182017-1](#) [SX1272MB2DAS 3179](#) [DC689A](#) [DC1513B-AB 3229](#) [3230](#) [3231](#) [3232](#) [DC1250A-AA](#) [DC1513B-AC](#) [DC1513B-AD](#) [DC1513B-AA](#) [TEL0075](#) [131903-HMC921LP4E](#) [EU-SIGFOX-GEVB](#) [856512-EVB](#)