

Secure element expansion board based on STSAFE-A110

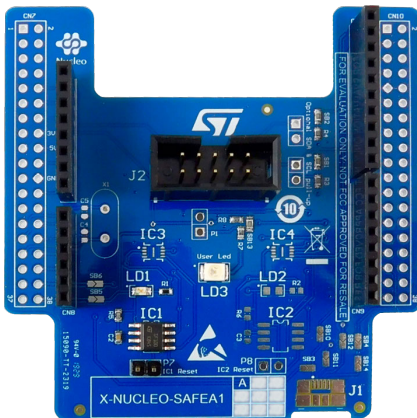

Features

- On-board [STSAFE-A110](#) customized with a standard evaluation profile
- HE10 extension connector to mount additional STSAFE devices
- Arduino UNO R3 connector
- Free drivers, middleware and software samples compatible with the [STM32 ODE](#)
- RoHS and WEEE compliant

Description

The [X-NUCLEO-SAFEA1](#) expansion board is based on the [STSAFE-A110](#) secure element. It can be used with any [STM32 Nucleo](#) development board.

The on-board STSAFE-A110 is customized with a standard profile for evaluation and is compatible with the Arduino UNO R3 connector.

The [X-NUCLEO-SAFEA1](#) expansion board is used with free [X-CUBE-SAFEA1](#) or [X-CUBE-SBSFU](#) software packages containing sample code to demonstrate how to implement security applications.

Product summary

Secure element expansion board based on STSAFE-A110	X-NUCLEO-SAFEA1
Authentication and brand protection secure solution	STSAFE-A110
Provides drivers, middleware and several code examples to demonstrate the features of the STSAFE-A110 device from a STM32 host microcontroller	X-CUBE-SAFEA1
Secure boot and secure firmware update software expansion for STM32Cube	X-CUBE-SBSFU

1 Schematic diagrams

Figure 1. X-NUCLEO-SAFEA1 circuit schematic - STSAFE-A chips

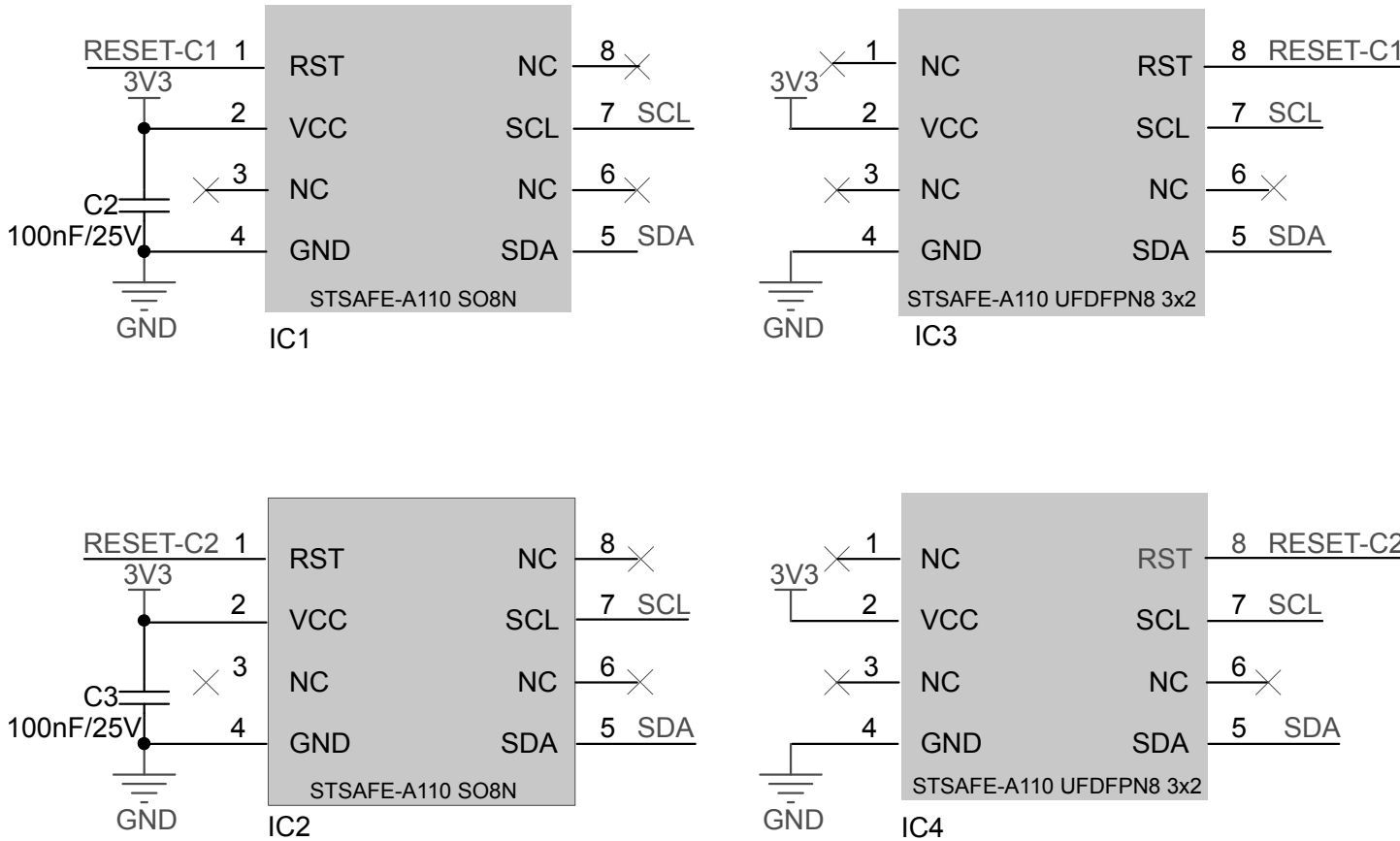

Figure 2. X-NUCLEO-SAFEA1 circuit schematic - Arduino and morpho connectors

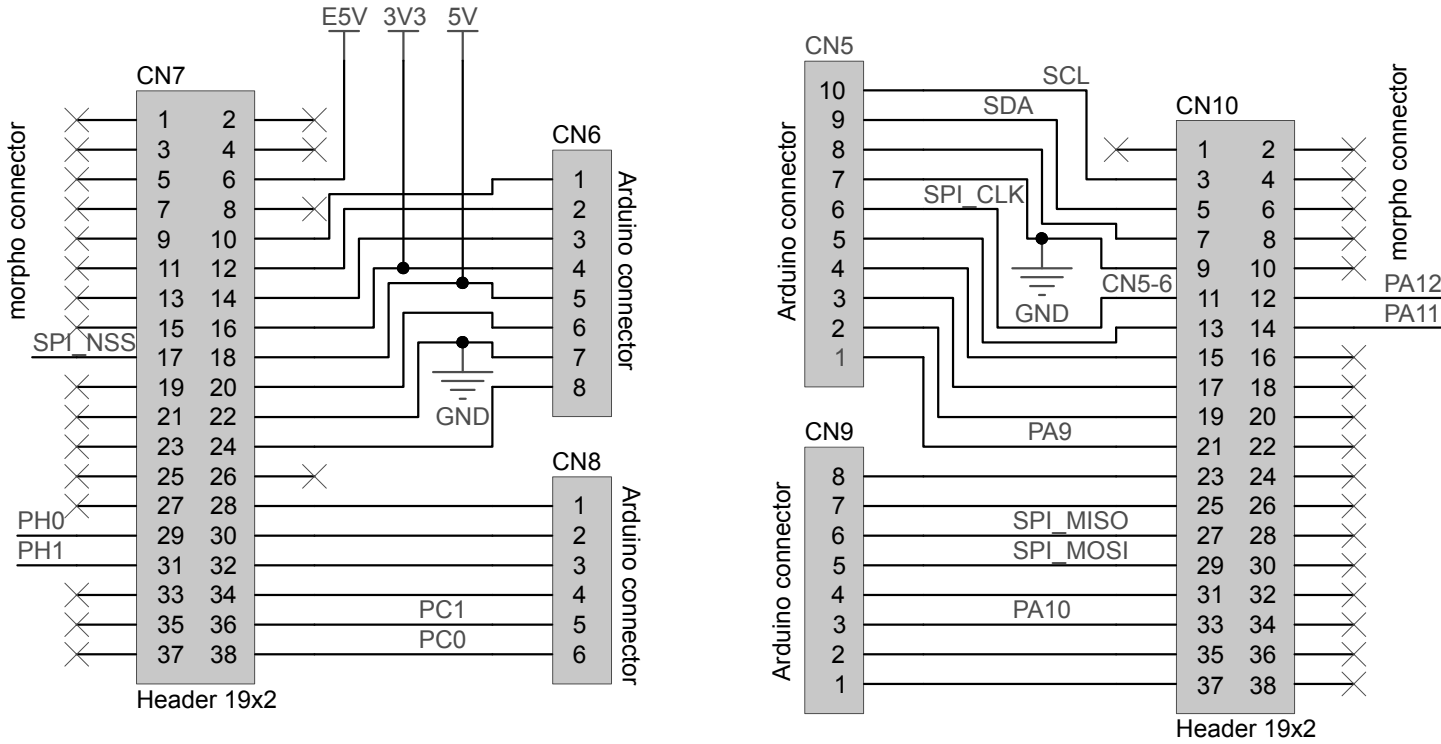
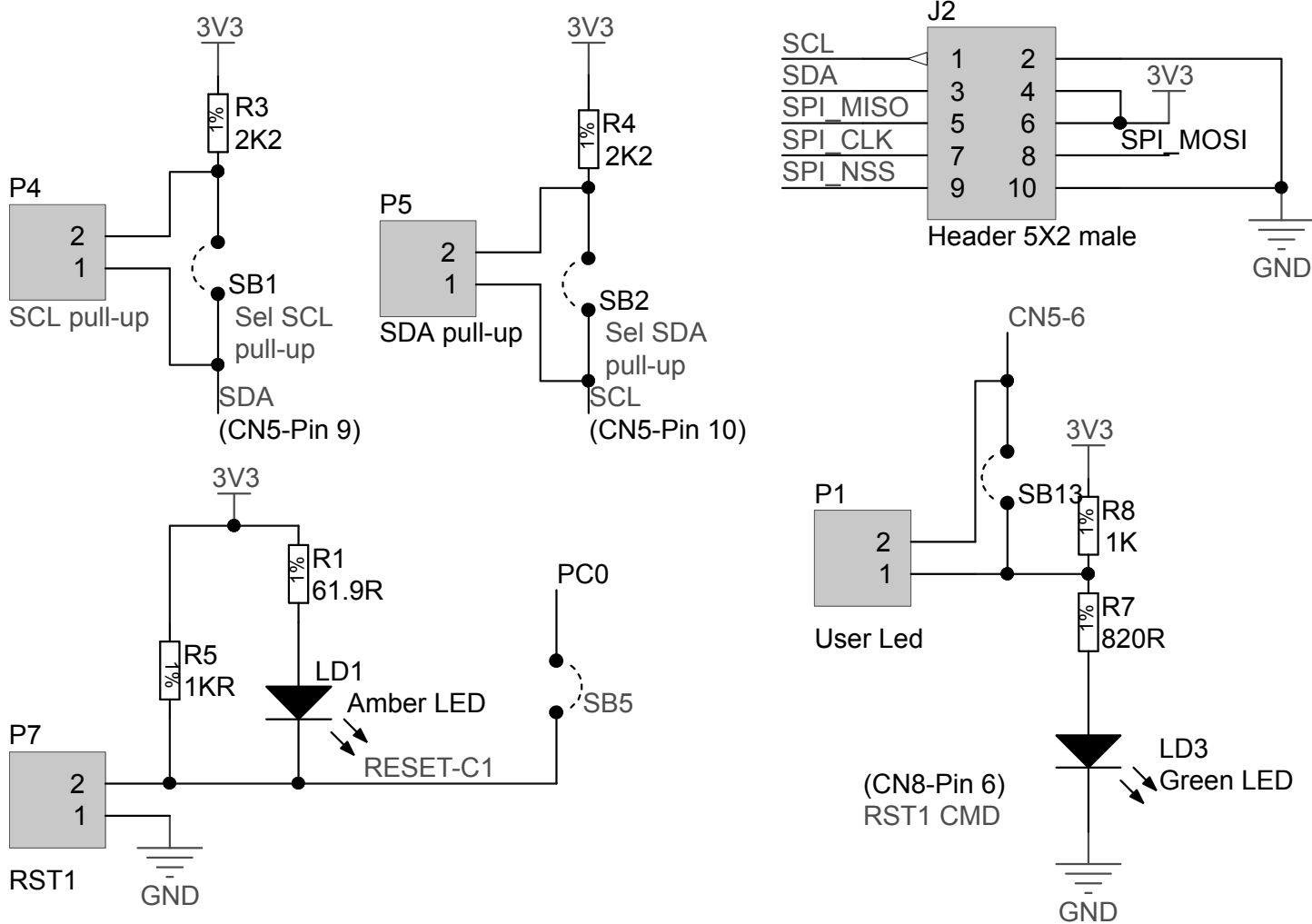

Figure 3. X-NUCLEO-SAFE1 circuit schematic - LEDs and jumpers

Revision history

Table 1. Document revision history

Date	Version	Changes
11-Oct-2019	1	Initial release.
14-Jan-2020	2	Updated information to reflect upgraded STSAFE-A110 device Added X-CUBE-SAFEA1 software compatibility information Minor text edits

IMPORTANT NOTICE – PLEASE READ CAREFULLY

STMicroelectronics NV and its subsidiaries (“ST”) reserve the right to make changes, corrections, enhancements, modifications, and improvements to ST products and/or to this document at any time without notice. Purchasers should obtain the latest relevant information on ST products before placing orders. ST products are sold pursuant to ST’s terms and conditions of sale in place at the time of order acknowledgement.

Purchasers are solely responsible for the choice, selection, and use of ST products and ST assumes no liability for application assistance or the design of Purchasers’ products.

No license, express or implied, to any intellectual property right is granted by ST herein.

Resale of ST products with provisions different from the information set forth herein shall void any warranty granted by ST for such product.

ST and the ST logo are trademarks of ST. For additional information about ST trademarks, please refer to www.st.com/trademarks. All other product or service names are the property of their respective owners.

Information in this document supersedes and replaces information previously supplied in any prior versions of this document.

© 2020 STMicroelectronics – All rights reserved

X-ON Electronics

Largest Supplier of Electrical and Electronic Components

Click to view similar products for [Security/Authentication Development Tools](#) category:

Click to view products by [STMicroelectronics](#) manufacturer:

Other Similar products are found below :

[MAX16984EVKIT#](#) [MAXREFDES132#](#) [DS28E25EVKIT#](#) [MAX20010EVKIT#](#) [MAX15068EVKIT#](#) [MAX98091EVKIT#TQFN](#) [IPL-003WR](#) [ATCRYPTOAUTH-XPRO](#) [BLOCKCHAINSTARTKITTOBO1](#) [IRID9670TPM12LINUXTOBO1](#)
[OPTIGATRUSTEEVALKITTOBO1](#) [MAX66240EVKIT#](#) [MAXAUTHDEMO1#](#) [DS28C16EVKIT#](#) [DS28C39EVKIT#](#) [DS28C40EVKIT#](#)
[DS28C50EVKIT#](#) [DS28E15EVKIT#](#) [DS28E16EVKIT#](#) [DS28E22EVKIT#](#) [DS28E39EVKIT#](#) [DS28E50EVKIT#](#) [DS28E83EVKIT#](#)
[DS28E84EVKIT#](#) [DS28EL15EVKIT#](#) [MAXREFDES143#](#) [MAXREFDES43#](#) [MAXREFDES44#](#) [AT88CK590](#) [AT88CKECC-AWS-XSTK-B](#) [ATCRYPTOAUTH-XPRO-B](#) [DM320109](#) [DM320118](#) [DT100104](#) [MIKROE-3746](#) [MIKROE-3774](#) [MIKROE-3915](#) [MIKROE-4236](#)
[MIKROE-1819](#) [MIKROE-2829](#) [MIKROE-3045](#) [OM3710/A71CHARD](#) [OM-SE050ARD](#) [102010288](#) [AT97SC3205P-SDK2](#) [AT97SC3205T-SDK2](#) [ATECC108XPLAINED](#) [MAXREFDES34#](#) [DS28E38EVKIT#](#) [AT88CKECC-AWS-XSTK](#)