



To indicate the presence of an active recording system the Storm ATP Microphone Activation Sensor incorporates a highly visible and tactile microphone icon.

The device also includes an infrared (IR) proximity sensor that can be used to activate a microphone for Speech Recording or Voice Commanded applications.

Self Service Terminals equipped with voice recording, voice recognition or voice command are being increasingly deployed in public. However, this has raised concerns about privacy among members of the public and has prompted government agencies to review privacy regulations.

It is important that members of the public in the immediate vicinity of those terminals are made aware that voice capture technology is available at that location and may be active or in use. It may also be required that microphones situated in public spaces are, by default, maintained in a muted (or closed) condition until required for use.

The status of any microphone must be immediately obvious to anyone within recording range. These features are essential to maintain personal privacy and meet mandated requirements for personal data protection.

Storm Assistive Technology Products provide improved system accessibility for those with impaired vision, restricted mobility, limited dexterity or reading difficulties.

- The device enumerates as a USB Human Interface Device (no special drivers required).
- The device automatically calibrates for background IR levels on power up. (The icon illumination flashes during this calibration process).
- The IR Sensor detects the presence of a person within the 'activation zone' and sends a USB code to the host. This so the host can activate (open) a microphone at the appropriate time.
- When a person disappears from range the device sends a different USB code to the host. This so the host can mute (close) a microphone at the appropriate time.
- An API is provided so that the host can control specific features of the device:
  - Turn the Icon illumination on or off to indicate whether a microphone is active or muted.
  - Change the brightness of icon illumination to compensate for day / night background light levels
  - Customise the USB codes that are sent to the host by the device.

Microphone Activation Sensor	Part Numbers
Microphone Activation Sensor	AT01-12001
USB 2.0 Cable, 90cm long, angled mini-B male connector to Type A male connector	4500-01
Microphone Array Kit (Includes Microphone Array Module Activation Sensor & cables)	AT00-15001-KIT

Storm Interface products are developed primarily for use with current and supported Microsoft Windows® platforms. For use with a non-Windows® platform, please contact Storm Interface for advice. Compatibility with non-Windows® platforms or operating systems cannot be guaranteed. Storm, Storm Interface, Storm AXS & Storm ATP are trademarks of Keymat Technology Ltd. This product includes proprietary technology and intellectual property retained by Keymat Technology Ltd (trading as Storm Interface). All rights reserved.



### Performance

Vibration & Shock:  
Impact Resistance:  
Certification:  
EMC:

ETSI 5M3  
IK09 (10J rating)  
CE / FCC / UL  
55032 Class B (Emissions)  
55035 (Immunity)  
47CFR15 Class B (Emissions)  
15kV Contact and Air  
Compliant

FCC:  
ESD Immunity:  
EN 301 549 / ADA:

### Environmental

Operational Temperature:  
Weather Resistance:

-20°C to +70°C (dry)  
IP65 (when panel mounted)

### Specification

O/S Compatibility:

Compatible with currently supported versions of Microsoft Windows  
5V ±0.25V (USB 2.0)  
Mini USB B Socket

Rating  
Connection:

For more information & to order visit:  
[www.storm-interface.com](http://www.storm-interface.com)

ATP 1400EF Dec 2019

Whilst every effort is made to ensure details are correct at time of print, specifications are subject to change without notice.



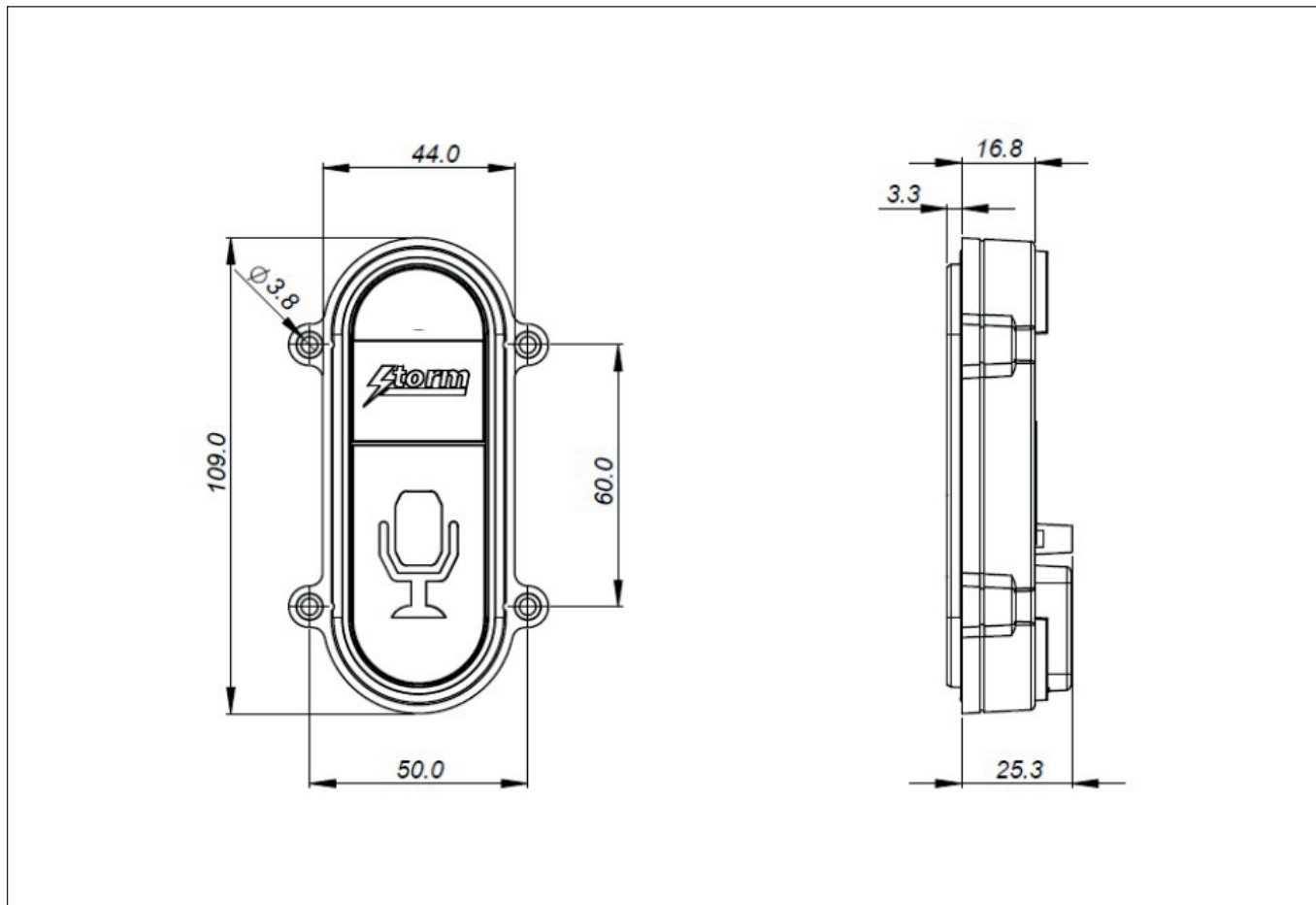

The Storm ATP Microphone Activation Sensor is a USB peripheral device that includes an internationally recognised microphone icon to indicate the presence of a voice recording device. The illuminated microphone icon is both highly visible and tactilely discernible.

When the integrated IR proximity sensor detects a person in the 'addressable zone' situated immediately in front of the terminal, it transmits a USB code to the host as a signal to activate the microphone and to illuminate the microphone icon.

The icon illuminates with a bright white light, giving a clear indication that voice recording is in process. An audible signal or message can also be triggered to inform blind users that "voice command is now activated". Another USB code is transmitted by the integrated sensor when the person moves away from the addressable zone and ceases to be detected by the sensor.

This second transmitted code can be used to close (mute) the microphone and turn off the illumination. This proximity sensing feature allows the microphone to be closed (muted) as its default condition. This is an important feature designed to protect the privacy of those in the general vicinity of the host terminal who may not be intending to use the voice recording or voice commanded technology.

Designed in consultation with the UK's Royal National Institute of Blind People, the Microphone Activation Sensor has been certified as an RNIB Tried & Tested product.

The microphone Activation Sensor is part of the Storm Assistive Technology Products range and is designed for use with the Storm ATP Microphone Array Module (part number AT00-15001), or other sound recording devices.

For more information & to order visit:  
[www.storm-interface.com](http://www.storm-interface.com)

ATP 1400EF Dec 2019 Whilst every effort is made to ensure details are correct at time of print, specifications are subject to change without notice.



## X-ON Electronics

Largest Supplier of Electrical and Electronic Components

*Click to view similar products for [Audio Modules](#) category:*

*Click to view products by [Storm Interface](#) manufacturer:*

Other Similar products are found below :

[E393242100](#) [OKY3462-3](#) [CI-C22GS02S](#) [DFR0699](#) [DFR0768](#) [MOTG MP3](#) [OKY2110](#) [OKY3131](#) [OKY3132](#) [OKY3134](#) [OKY3138](#)  
[OKY3151](#) [OKY3151-1](#) [OKY3152](#) [OKY3153](#) [OKY3154](#) [OKY3160](#) [OKY3161](#) [OKY3161-1](#) [OKY3163](#) [OKY3462](#) [OKY3462-1](#) [I2C FM](#)  
[RECEIVER V1.1](#) [4038](#) [OKY3133](#) [OKY3137](#) [OKY3151-2](#) [OKY3155](#) [OKY3156](#) [OKY3157](#) [SPEECH RECOGNIZER V1.0](#) [GROVE](#)  
[SPEECH RECOGNIZER KIT FOR ARDUINO](#) [DFR0719](#) [NA2-IO-DLINE](#) [OKY3102](#) [OKY3139](#) [OKY3166](#) [OKY3462-2](#) [AMP2X15](#)  
[SEN0325](#) [TSI-USB-C100-MODULE-A](#) [AIMB-AUDIO-HDA1E](#) [EZB2-505H03](#) [AT00-150016](#) [AT01-120016](#) [AT02-430016](#) [318BTS](#) [U437-](#)  
[002](#)