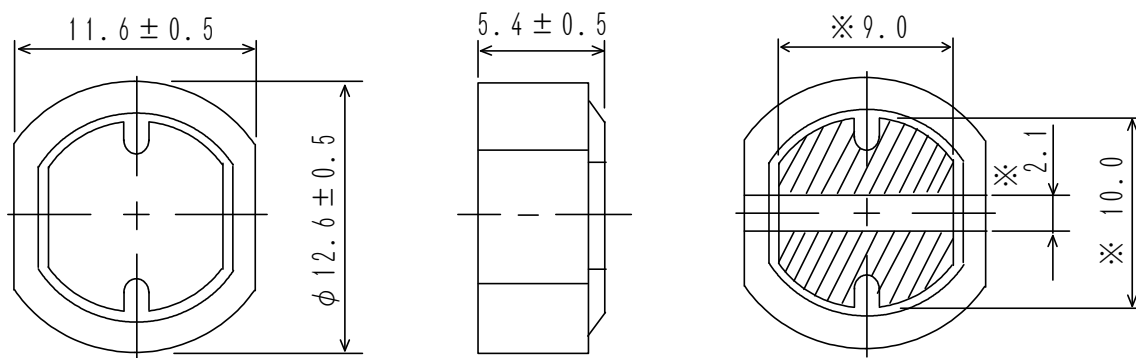
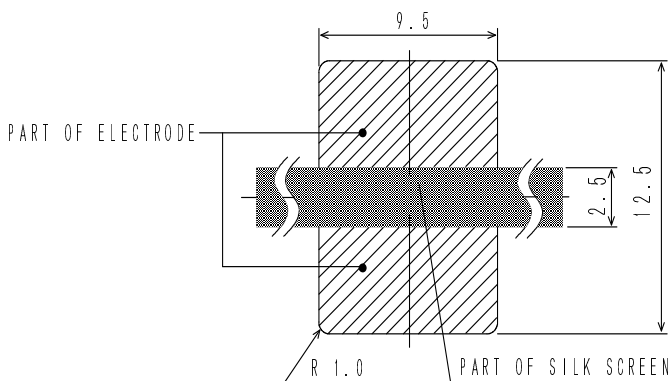

Type: CDR125
◆ Product Description

- 13.1 × 12.1mm Max.(L×W), 5.9mm Max. Height.
- Inductance range: 10~820 μ H.
- Rated current range: 0.36~2.65A .
- In addition to the standards versions shown here, custom inductors are also available to meet your exact requirements.

◆ Feature

- Magnetically shielded construction.
- Storage temperature range: -40°C ~+100°C.
- Operating temperature range: -40°C ~+100°C (Including coil's self temperature rise).
- Ideally used in Notebook PC ,LCD TV ,Game machine ,HDD,DSC/DVC, etc as DC-DC converter inductors.
- RoHS compliance.

◆ Dimensions (mm)

◆ Land Pattern (mm)

Type: CDR125
◆ Specification

Part name	Stamp	Inductance (μ H) ※1	D.C.R.(Ω) [Max.] (at 20°C)	Rated Current (A) ※2	S.R.F. (MHz) [Typ.]
CDR125NP-100M□	100M	10±20%	0.05	2.65	24.2
CDR125NP-120M□	120M	12±20%	0.05	2.50	21.2
CDR125NP-150M□	150M	15±20%	0.06	2.45	18.9
CDR125NP-180M□	180M	18±20%	0.06	2.40	16.1
CDR125NP-220M□	220M	22 +20% / -15%	0.07	2.20	15.2
CDR125NP-270M□	270M	27 +20% / -15%	0.08	2.00	13.9
CDR125NP-330M□	330M	33 +20% / -15%	0.10	1.80	12.8
CDR125NP-390M□	390M	39 +20% / -15%	0.11	1.65	11.6
CDR125NP-470M□	470M	47 +20% / -15%	0.12	1.50	10.4
CDR125NP-560M□	560M	56 +20% / -15%	0.15	1.38	9.12
CDR125NP-680M□	680M	68 +20% / -15%	0.17	1.26	8.50
CDR125NP-820M□	820M	82 +20% / -15%	0.20	1.14	7.85
CDR125NP-101M□	101M	100 +20% / -15%	0.25	1.05	6.92
CDR125NP-121M□	121M	120 +20% / -15%	0.28	0.95	6.34
CDR125NP-151M□	151M	150 +20% / -15%	0.40	0.85	5.55
CDR125NP-181M□	181M	180 +20% / -15%	0.48	0.77	5.10
CDR125NP-221M□	221M	220 +20% / -15%	0.52	0.70	4.51
CDR125NP-271M□	271M	270 +20% / -15%	0.70	0.63	4.37
CDR125NP-331M□	331M	330 +20% / -15%	0.80	0.57	3.90
CDR125NP-391M□	391M	390 +20% / -15%	1.08	0.52	3.55
CDR125NP-471M□	471M	470 +20% / -15%	1.20	0.48	3.25
CDR125NP-561M□	561M	560 +20% / -15%	1.34	0.44	2.94
CDR125NP-681M□	681M	680 +20% / -15%	1.78	0.40	2.64
CDR125NP-821M□	821M	820 +20% / -15%	2.00	0.36	2.42

※ Description of part name

CDR125NP-100M□
 └── B Box
 └── C Carrier Tape

※1: Measuring frequency: 10 μ H ~ 82 μ H ; at 2.52 MHz

100 μ H ~ 820 μ H ; at 1 kHz

※2: Rated current: The D.C. current at which the inductance decreases to 75%(10 μ H~18 μ H) and 80% (22 μ H~820 μ H) of it's initial value or when $\Delta t=40^{\circ}\text{C}$, whichever is lower($T_a=20^{\circ}\text{C}$).

X-ON Electronics

Largest Supplier of Electrical and Electronic Components

Click to view similar products for [Fixed Inductors](#) category:

Click to view products by [Sumida](#) manufacturer:

Other Similar products are found below :

[MLZ1608M6R8WTD25](#) [MLZ1608N6R8LT000](#) [MLZ1608N3R3LTD25](#) [MLZ1608N3R3LT000](#) [MLZ1608N150LT000](#)
[MLZ1608M150WTD25](#) [MLZ1608M3R3WTD25](#) [MLZ1608M3R3WT000](#) [MLZ1608M150WT000](#) [MLZ1608A1R5WT000](#)
[MLZ1608N1R5LT000](#) [B82432C1333K000](#) [PCMB053T-1R0MS](#) [PCMB053T-1R5MS](#) [PCMB104T-1R5MS](#) [CR32NP-100KC](#) [CR32NP-151KC](#) [CR32NP-180KC](#) [CR32NP-181KC](#) [CR32NP-1R5MC](#) [CR32NP-390KC](#) [CR32NP-3R9MC](#) [CR32NP-680KC](#) [CR32NP-820KC](#)
[CR32NP-8R2MC](#) [CR43NP-390KC](#) [CR43NP-560KC](#) [CR43NP-680KC](#) [CR54NP-181KC](#) [CR54NP-470LC](#) [CR54NP-820KC](#) [CR54NP-8R5MC](#)
[MGDQ4-00004-P](#) [MGDU1-00016-P](#) [MHL1ECTTP18NJ](#) [MHL1JCTTD12NJ](#) [PE-51506NL](#) [PE-53601NL](#) [PE-53630NL](#) [PE-53824SNLT](#) [PE-62892NL](#) [PE-92100NL](#) [PG0434.801NLT](#) [PG0936.113NLT](#) [PM06-2N7](#) [PM06-39NJ](#) [HC2LP-R47-R](#) [HC2-R47-R](#) [HC3-2R2-R](#) [HC8-1R2-R](#)