

CONNECTRAL

8140 series



FCI

FRAMATOME CONNECTORS
INTERNATIONAL

CONNECTRAL 8140 series



Fichiers à éléments assemblés Modular connectors

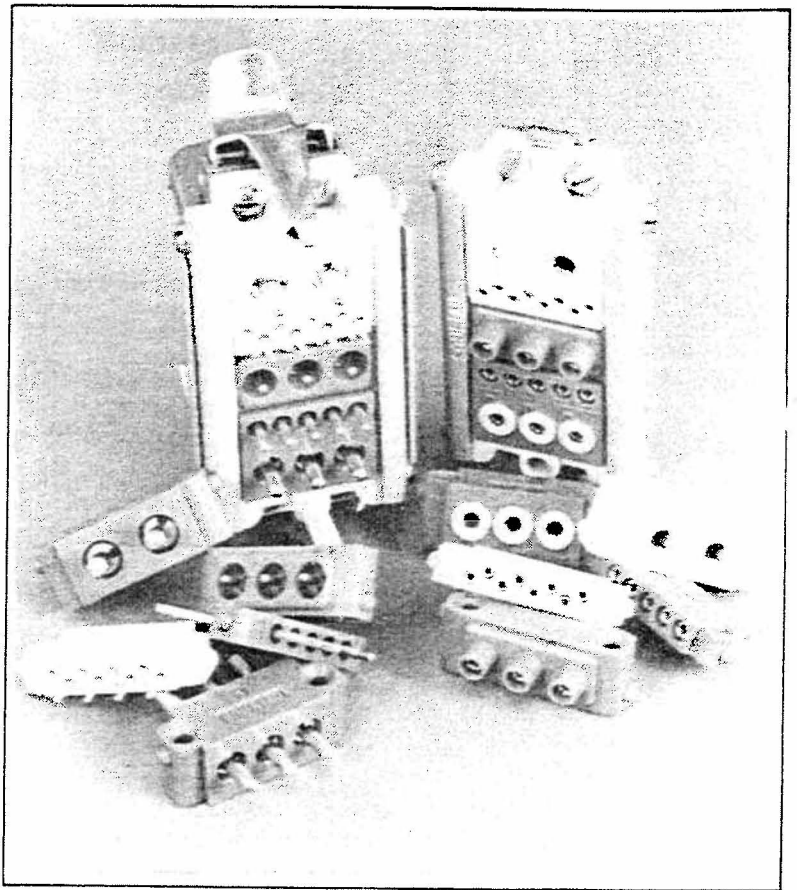

Généralités

Simple assemblage de pièces détachées permettant la réalisation immédiate de connecteurs de brochages différents, telle est la fonction des fichiers à éléments assemblés 8140.

La seule limite est la force d'insertion ou d'extraction des contacts. Dans le cas de connecteur à brochage important, un extracteur peut être placé au milieu du fichier.

La qualité des contacts permet un nombre élevé de manœuvres, tout en conservant une pression de contact constante et une résistance de contact très faible.

Cinq types de connecteurs peuvent être réalisés :

- Fichier standard 8*40.
- Fichier pour rack 8*41.
- Fichier simple avec extracteur 8*42.
- Fichier double avec extracteur 8*43.
- Fichier pour rack avec extracteur 8*44.

L'astérisque qui suit le chiffre 8 doit être remplacé lors de la commande par un nombre définissant le type des éléments désirés (voir système de référence). Tous ces types de connecteurs peuvent être assemblés par notre clientèle ou vus assemblés par nos ateliers.

General information

The 8140 modular connector system is designed to enable connectors with a very wide range of different pin layout to be quickly and simply assembled from modular component.

The only limitation is the insertion or extraction force of the contacts. In case of a large number of pins a screw type extractor can be built into the center of the connector.

The high quality of the contacts, allows a large number of insertions whilst keeping constant contact pressure and very low contact resistance.

Five types of connectors can be assembled :

- Standard connector 8*40.
- Rack connector 8*41.
- Single bank connector with extractor 8*42.
- Double bank connector with extractor 8*43.
- Rack connector with extractor 8*44.

To place order, the asterisk must be replaced by a number as explained in our reference system page 6.

All these types of connectors can be assembled either by our customers or in our plant.

CONNECTRAL 8140 series



Les supports

Un fichier comporte un nombre variable d'éléments qui maintiennent 2 rails en alliage léger accouplés par 2 équerres extrémité mâles ou femelles qui assurent le guidage des parties du connecteur.

Les éléments

Les corps des éléments sont :

- Soit en nylon auto extinguible UL94Vo beige s'ils comportent des contacts : \varnothing 1,5 ; \varnothing 2,5 ; \varnothing 3,5 mm.
- Soit en alliage léger s'ils comportent des contacts coaxiaux.

Les éléments existent en trois largeurs différentes :

- Éléments simples pouvant comporter 5 contacts \varnothing 1,5 mm ou 8 contacts \varnothing 1 mm.
- Éléments doubles pouvant comporter 3 contacts 2,5 mm ; 2 contacts \varnothing 3,5 mm, 24 contacts \varnothing 1 mm, contacts \varnothing 1,5 mm haute tension, 2 contacts coaxiaux MVR Sec 3 contacts coaxiaux MCO.
- Éléments triples pouvant comporter 1 contact coaxial BNC.

La longueur des éléments est constante.
Les contacts sont numérotés.

Chaque élément est muni à ses extrémités d'un téton de centrage. Les rails de fixation sont percés de trous à espacement régulier garantissant le bon positionnement des contacts.

Les contacts

Les contacts sont présentés en version à souder, à sertir, coaxiale, à wire wrap.
Seules les broches et douilles des éléments 3 contacts \varnothing 2,5 mm et 2 contacts \varnothing 3,5 mm sont démontables.

Les capots

Chaque connecteur peut être muni d'un capot métallique dont les sorties à serre-câbles peuvent être placées sur toutes les faces du capot.

Pour les connecteurs constitués par un ou deux éléments simples ou 1 élément double, un capot en matière plastique

Test voltages la protection des queues de contacts.

Verrouillage

Le verrouillage peut être réalisé de 2 façons :

- Soit par deux ressorts solidaires du fichier fixe venant se cranter sur les équerres de capot du fichier mobile.
- Soit par deux doigts solidaires du fichier mobile venant se cranter sur les équerres du fichier fixe.

Pièces spéciales pour fichiers 8*42 - 8*43 - 8*44

À partir de dix éléments simples un extracteur doit être placé au milieu du connecteur. Afin d'équilibrer l'effort d'extraction il est recommandé de placer symétriquement en partant de l'extracteur vers les équerres d'extrémité, les éléments triples, doubles puis simples.

L'extracteur se manœuvre avec un tournevis ou une clé à six pans 5 s/p).

À partir de 16 et jusqu'à 32 éléments simples, le montage est effectué par le jumelage en largeur de 2 connecteurs réalisés dans un support spécial avec extracteur au centre. Ce support est un cadre rigide en I.

Frame

A connector consists of a variable number of modules grouped in a frame comprising two channels in light alloy and held together by two end piece spacers, male or female supplying the guiding system to the two part of the connector.

Modules

The module material is :

- Either autoextinguishable nylon beige if equipped with contacts : 1.5 p 2.5 or 3.5 mm \varnothing .
- Or light alloy for some coaxial modules.

There are three different module width :

- Single width modules can carry five contacts : 1.5 mm \varnothing or eight contacts 1 mm \varnothing .
- Double module can carry three contacts 2.5 mm \varnothing two contacts 1.5 mm \varnothing H.T., 24 contacts 1 mm \varnothing two coaxial contacts MVR or three coaxial contacts MCO.
- Triple modules can carry one coaxial BNC contact.

The length of the modules is constant.
The contacts are numbered.

Contacts

The contacts are available in different versions : solder, crimp, coaxial and wire wrap.
Only the pins and sockets of the three contacts 2.5 mm \varnothing and two contacts 3.5 mm \varnothing contacts can be unscrewed and removed from the module.

Hoods

Each connector can be fitted with a metal hood. The cable entries can be positioned on any face or the cover and include cable clamp.
For simple connector using only one or two single width module or one double width module, there is a alternative plastic hood.

Locking

The locking can be accomplished in two ways :

- Either with two springs fixed to the chassis mounted part.
- Or with two springs lever fixed to the mobile part.

Special parts for connectors 8*42 - 8*43 and 8*44

When there are more than ten single width modules an extractor can be placed in the middle of the connector. In order to equalise the extractor force this should be placed symmetrically with triple modules nearest the extractor, the double modules, then singles modules.

This extractor is operated with a screwdriver or an hexagonal socket spanner.
From 16 and to 32 single modules, assembly is made in a special frame which has the width of two modules and a central extractor. This frame is a rigid assembly with a I cross section.

CONNECTRAL 8140 series



Pièces spéciales pour fichiers 8*41 et 8*44

Pour ces connecteurs de racks, les équerres d'extrémité ordinaire sont remplacées sur l'une des parties du connecteur par deux équerres avec guide en acier et sur l'autre partie du connecteur par deux ensembles glissières assurant une fixation flottante.

Ce système de guidage et de fixation permet un décalage possible du tiroir par rapport au châssis de 1 mm maxi dans tous les sens.

Special part for connectors 8*41 et 8*44

For rack connectors normal end spacers are replaced on one part of the connector by two spacers with a steel guide pin and on the other part by two spacers assemblies carrying a floating guide hole.

This guidance system allows a misalignment between rack and chassis of 1 mm in each direction.

Spécifications

Mécaniques Mechanical	ELEMENT					
	Simple 5 contacts Single 5 contacts	Double 3 contacts	Double 2 contacts	Simple 8 contacts Single 8 contacts	Double 24 contacts	Double HT 3 cts Double high voltage 3 contacts
Ø des contacts - Ø of contacts	1.5	2.5	3.5	1	1	1.5
Section maxi câble admissible Maxi cable cross sectionnel area	0.93 mm ²	1.91 mm ²	5.3 mm ²	0.6 mm ²	0.6 mm ²	0.93 mm ²
T° mini d'utilisation Mini-operating T°	- 60 °C	- 60 °C	- 60 °C	- 60 °C	- 60 °C	- 60 °C
T° maxi d'utilisation Maxi operating T°	+ 90 °C	+ 90 °C	+ 90 °C	+ 125 °C	+ 125 °C	+ 90 °C
Effort d'attachement maxi (en kg) p. elem. Maxi withetral force per module (in kg)	3	4.5	4.5	1.5	4.5	2.7

Électriques Electrical	ELEMENT					
	Simple 5 contacts Single 5 contacts	Double 3 contacts	Double 2 contacts	Simple 8 contacts Single 8 contacts	Double 24 contacts	Double HT 3 cts Double high voltage 3 contacts
Intensité nominale Nominal current rating	7,5 A	15 A	25 A	5 A	5 A	15 A
Tension de claquage en V eff au sol Break down voltage et ground level	2 500	3 500	> 4 000	2 000	2 000	> 5 000
Tension de claquage en V eff à 22 000 m	400	500	600	300	300	600
Break down voltage at 70 000 feet						
Tension d'essais en V eff au sol Test voltage at ground level	1 750	2 500	3 000	1 200	1 200	4 500
Résistance d'isolement en MΩ sous 500 VCC Insulation resistance in MΩ at 500 VDC	≅ 5 000	≅ 5 000	≅ 5 000	≅ 5 000	≅ 5 000	≅ 5 000
Résistance de contacts en mΩ Contact resistance in ohms × 10 ⁻³	≤ 1	≤ 1	≤ 1	≤ 2	≤ 2	≤ 1

Éléments coaxiaux - Coaxial elements

Type d'élément Type of element	Type de contact Type of contact	Impédance Ω	Fréquence maxi Maxi frequency	Type de câble Type of cable	Matière des contacts Contacts material	
					Mâles Males	Femelles Females
Triple 1 contact	BNC (C 3608)	50	1 000 MHz *500 V en pointe	RG 58 CU KX 15 Ø 5.2 mm	Laiton	Beryllium
Double 2 contacts	M.V.R.	50	6 000 MHz 500 V en pointe	RG 58 CU KX 15 Ø 5.2 mm	Laiton	Beryllium
Double 3 contacts	MCO	50	6 000 MHz 500 V en pointe ou Rg 178 AU (KX21)	Teflon 50 SH (196 AU) Ø est max 2.2 mm	Laiton	Beryllium

CONNECTRAL 8140 series



Principe d'assemblage d'un fichier Principle of assembly

Cette vue éclatée montre comment doivent être assemblés les différents éléments constitutifs d'un fichier 8140. Ne pas oublier que les rails doivent toujours être coupés entre deux trous.

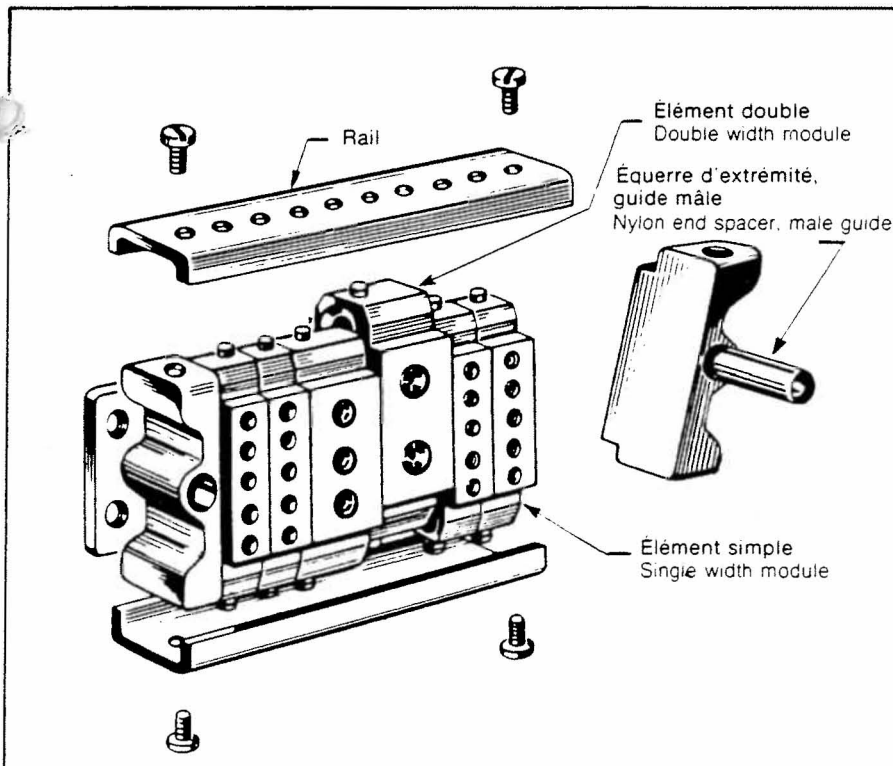
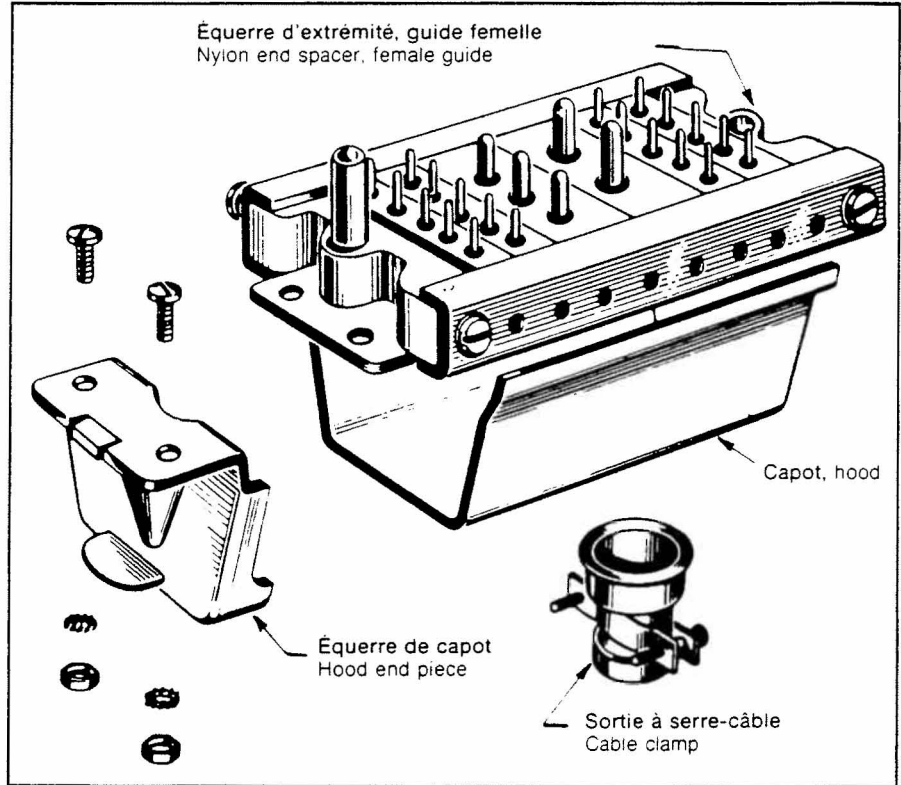

This view shows how the different parts of an 8140 connector must be assembled. Note that channels must always be cut between two holes.



Pour passer commande

Deux méthodes possibles :

- 1) Composer la référence selon le système indiqué page suivante.
 - 2) Décrire le fichier désiré.
- Pour cette méthode, les renseignements, ci-après, nous sont absolument nécessaires.

A. Pour un fichier standard 8140

- Le nombre d'éléments :
5 contacts Ø 1,5 mm, 3 contacts Ø 2,5 mm, 2 contacts Ø 3,5 mm, 8 contacts Ø 1 mm, 24 contacts Ø 1 mm, 1 contact coaxial, 2 contacts coaxiaux, 3 contacts Ø 1,5 mm haute tension.
- Le type des contacts : mâle ou femelle (à souder, à sertir, à wire wrap).
- Le type de verrouillage désiré (ou s'il n'y a pas besoin de verrouillage).
- Si le fichier doit comporter un capot et, dans ce cas, nous définir le nombre, le diamètre et l'emplacement du ou des serre-câbles (ou s'il n'en faut pas).

B. Pour un fichier pour rack 8141

- Le nombre d'éléments : 5 contacts Ø 1,5 mm, 3 contacts Ø 2,5 mm, 2 contacts Ø 3,5 mm, 8 contacts Ø 1 mm, 24 contacts Ø 1 mm, 1 contact coaxial, 2 contacts coaxiaux, 3 contacts coaxiaux, 3 contacts Ø 1,5 H.T.
- Le type de contacts désirés : mâle ou femelle (à souder, à sertir, à wire wrap).
- S'il faut un ensemble de fixation glissière, ou une équerre avec guide acier.
- Si le fichier doit comporter un capot et, dans ce cas, le nombre, le diamètre et l'emplacement des serre-câbles (ou s'il n'en faut pas), ne pas oublier l'entretoise 8140-332 s'il y a lieu.

C. Pour un fichier simple avec extracteur 8142, et fichier double avec extracteur 8143

- Le nombre d'éléments : 5 contacts Ø 1,5 mm, 3 contacts Ø 2,5 mm, 2 contacts Ø 3,5 mm, 8 contacts Ø 1 mm, 24 contacts Ø 1 mm, 1 contact coaxial, 2 contacts coaxiaux, 3 contacts coaxiaux, 3 contacts Ø 1,5 haute tension entre l'extracteur et l'une des équerres d'extrémités.
- Le type de contacts désirés : mâles ou femelles (à souder, à sertir, à wire wrap).
- Si le fichier doit comporter 1 guide, 2 guides (ou pas).
- Si le fichier doit comporter un capot et, dans ce cas, nous définir le nombre, le diamètre et l'emplacement du ou des serre-câbles (ou s'il n'en faut pas).

Il est recommandé de fournir un schéma du fichier désiré. Nous rappelons que pour équilibrer l'effort d'extraction il est nécessaire de placer symétriquement, en partant de l'extracteur ou du centre du connecteur vers les équerres d'extrémité les éléments triples, doubles puis simples.

To place an order

Two possible ways:

- 1) Built the reference as explained on the following page.
 - 2) Describe the connector required.
- For this method, the following information is absolutely necessary.

A. For a standard connector 8140 it is necessary to state:

- The number of modules: 5 contacts Ø 1.5 mm, 3 contacts Ø 2.5 mm, 2 contacts 3.5 mm, 8 contacts Ø 1 mm, 24 contacts Ø 1 mm, 1 contact coaxial, 2 contacts coaxial, 3 contacts coaxial, 1 contact Ø 1.5 mm. High tension.
- The type of contacts : Male or females ; solder, crimp, wire wrap or.
- Whether locking is required and, if so, what type.
- Whether 2 guide pins, 1 guide pin or no guide pins are required.
- If a cover is required and, if so, precise information on number, diameter and positioning of cable clamps.

B. For a rack connector 8141

- The number of modules: 5 contacts Ø 1.5 mm, 3 contacts Ø 2.5 mm, 2 contacts Ø 3.5 mm, 8 contacts Ø 1 mm, 24 contacts Ø 1 mm, 1 contact coaxial, 2 contacts coaxial, 3 contacts coaxial, 3 contacts Ø 1.5 mm. High tension.
- The type of contacts: Male or female; solder, crimp, wire wrap. If the connector is to be a floating assembly on fixed mounts or a mating part with steel guide pins.
- Whether a cover is needed and if so state the number of cable entries required and their positioning and also whether part number 8140-322 is needed.

C. For a single connector with extractor 8142 and double connector with extractor 8143

- The number of modules: 5 contacts Ø 1.5 mm, 3 contacts Ø 2.5 mm, 2 contacts Ø 3.5 mm, 8 contacts Ø 1 mm, 24 contacts Ø 1 mm, 1 contact coaxial, 2 contacts coaxial, 3 contacts coaxial, 3 contacts Ø 1.5 mm. High tension between the extractor and each end spacer.
 - The type of contacts needed: Male or female; solder, crimp, wire wrap.
 - State if a cover is needed and if so state the number of cable clamps required and their positioning.
- We recommend you to prepare a sketch of the connector required. In order to equalise the extractor force, the modules should be placed symmetrically around the extractor with triple modules nearest to the extractor, then double modules, finally single modules.

CONNECTRAL 8140 series



Références - References

8 1 40 3 0 0 2 5 1

Séries - Series _____

Type d'éléments - Type of elements _____

Standard	1
Miniature	4
Haute tension - High voltage	5
Coaxiaux - Coaxials	8
Panachés - Mixed	6

Type de fichier - Type of modul _____

Standard simple - Single standard	0
For rack - For rack	1
Standard + extracteur - Standard + extractor	2
Double + extracteur - Double + extractor	3
Rack + extracteur - Rack + extractor	4

Nombre d'éléments - Number of elements _____

Standard 5 contacts (Éléments simples) (Singles elements)	}	3	0	0
Haute tension, coaxiaux (1 contact) High voltage, coaxials (1 contact)				
Miniatures 8 ^{ou} or 24 contacts		0		

Nombre d'éléments - Number of elements _____

Standard 3 contacts (Toujours double) Miniature 8 contacts (Always double)	}	3	0	0
Haute tension, coaxiaux High voltage, coaxials				
Miniatures 24 contacts		0		

Nombre d'éléments - Number of elements _____

Standard 2 contacts Miniature 24 contacts (Always double)	}	3	0	0
Coaxiaux 3 contacts - Coaxials 3 contacts				
Haute tension - High voltage		0		

Sexe et type du contact - Sex and type of contact _____

Montage - Mounting _____

Voir tableau des variantes - See table of variants

CONNECTRAL 8140 series



Variantes Variants

Type de contacts Type of contacts	Mâles Males	Femelles Females
A souder - Solder	2	1
A sertir - Crimp	4	3
Coaxiaux - Coaxials	8	7
Wire wrap	0	9

8.41 Fichier pour rack	
Avec glissière With end spacer with florting guide	1
Avec guide With guide	2

8.40 fichiers simples à partir de 3 éléments Simple connector 8.40 3 modules and more			
Variante	Sans verrouillage Without locking	Avec verrouillage	
		Type 1 8140.31	Type 2 8140.293/259
2 guides femelles - 2 females guides	0	5	7
1 guide mâle - 1 guide femelle	1	2	6
2 guides mâles - 2 males guides	3	4	8

8.40 fichiers simples inférieurs à 3 éléments montage avec capot plastique			
Fiche plug	Avec verrouillage With locking	+ 4 patte de guidage + Guide plate	23
		Sans patte de guidage Without guide plate	53
	Sans verrouillage Without locking	+ Patte de guidage + Guide plate	13
		Without guide plate	03
Embase sans capot 1 guide mâle 1 guide femelle	Connector without hood 1 male guide 1 female guide	Avec bande d'accrochage With locking strip	20
		Sans bande d'accrochage Without locking strip	10

fichiers 8.42 et 8.44 pour rack. 1 guide mâle, 1 guide femelle avec extracteur 8.42 and rack 8.44 connectors. 1 male guide, 1 female guide with extractor.								
11	21	31	41	61	81	13	23	26
36	15	35	55	75	25	45	65	85
20	30	60	80	28	38	48	58	68
78	24	34	44	54	64	74		
Serre-câbles, cable clamps : ■ = Ø 14,5 X = Ø 16 ▲ = Ø 12 ● = Section ovale, oval section							Sans capot Without hood } 00	

CONNECTRAL 8140 series



Fichiers simples, standard connector 8.40
Fichier p. rack, rack and panel connector 8.41

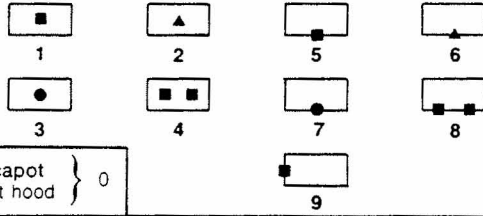

Sans capot } 0
Without hood } 0

Serre-câbles, cable clamps
■ Ø 14,5
▲ Ø 12
● Section ovale
Oval section

Dans le cas de sortie Ø 16,
nous consulter.
In case of cable clamp Ø 16
please consult us.

Ajouter une cale d'épaisseur réf. 8140 332 pour montage des équerres
de capot sur glissières Rack.
Add a chock ref. 8140 332 for mountings of the hood end pieces on end
spacer for Rack.

Brochage de fichiers standards

Les fichiers types représentés ci-dessus sont vus en bout
contacts mâles, le guide mâle toujours placé à gauche.



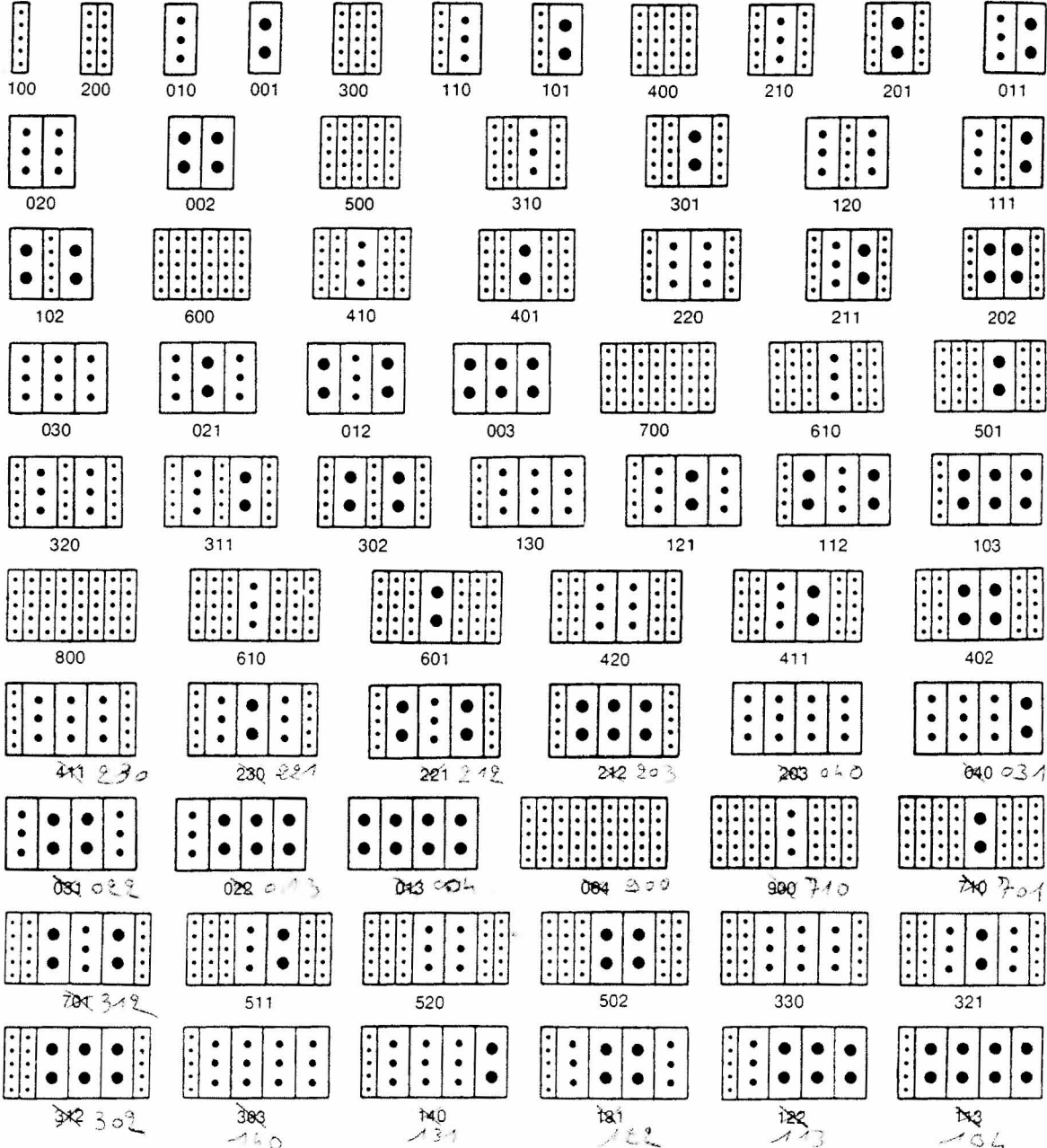







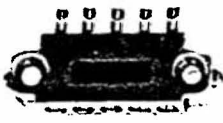



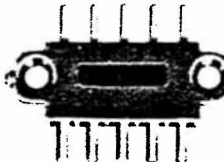

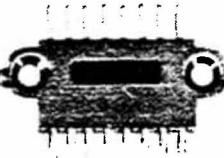
above assembled standard elements are shown on this
side, the male guide always on the left.

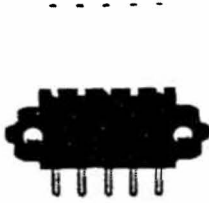

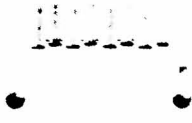
CONNECTRAL 8140 series

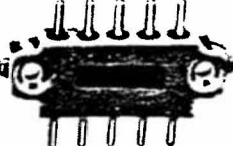

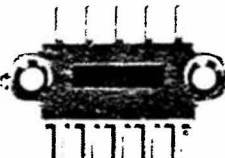



Pièces détachées - Éléments simples Spare parts - Single width modules

 <p>8140-01 3,1 g 5 douilles 1,5 mm à souder sur fil \approx 18 max. 5 sockets \varnothing 1,5 mm solder termination \approx 18 max.</p>	 <p>8140-02 3,8 g 5 broches 1,5 mm à souder sur fil \approx 18 max. 5 pins \varnothing 1,5 mm solder termination \approx 18 max.</p>	 <p>8140-110 3 g 5 douilles 1,5 mm à souder sur C.I. 5 sockets \varnothing 1,5 mm solder termination for printed circuit.</p>	 <p>8140-70 3,6 g 5 broches 1,5 mm à souder sur C.I. 5 pins \varnothing 1,5 mm solder termination for printed circuit</p>
 <p>8140-105 5 douilles 1,5 mm à sertir \approx 18 max. 5 sockets \varnothing 1,5 mm crimp termination \approx 18 max.</p>	 <p>8140-104 3,9 g 5 broches 1,5 mm à sertir \approx 18 max. 5 pins \varnothing 1,5 mm crimp termination \approx 18 max.</p>	 <p>8140-116 3,5 g 8 douilles à souder 1,5 mm sur fil. 8 sockets \varnothing 1,5 mm solder termination.</p>	 <p>8140-115 4,2 g 8 broches 1,5 mm à souder sur fil. 8 pins \varnothing 1,5 mm solder termination.</p>
 <p>8140-128 3,65 g 5 douilles 1,5 mm wire wrap. 5 sockets 1,5 mm wire wrap.</p>	 <p>8140-127 4,24 g 5 broches 1,5 mm wire wrap. 5 pins \varnothing 1,5 mm wire wrap.</p>	 <p>8140-1044 3,9 g 8 douilles \varnothing 1 mm mini wire wrap. 8 sockets \varnothing 1 mm mini wire wrap.</p>	 <p>8140-1043 4,6 g 8 broches \varnothing 1 mm mini wire wrap. 8 pins \varnothing 1 mm mini wire wrap.</p>
 <p>8140-1045 3,6 g 8 douilles \varnothing 1 mm à souder sur C.I. 8 sockets \varnothing 1 mm with straight spills for P.C.B. mounting.</p>	 <p>8140-1046 4,5 g 8 broches \varnothing 1 mm à souder sur C.I. 8 pins \varnothing 1 mm with straight spills for P.C.B. mounting.</p>	 <p>8140-1055 3,4 g 5 douilles \varnothing 1,5 mm intermédiaire (mâle, femelle). 5 sockets \varnothing 1,5 mm with straight spills intermediate piece (male, female).</p>	 <p>8140-1056 3,8 g 5 broches \varnothing 1,5 mm intermédiaire (mâle, mâle). 5 pins \varnothing 1,5 mm with straight spills intermediate piece (male, male).</p>
 <p>8140-5027 3,3 g 5 douilles démontables \varnothing 1,5 mm à sertir \approx 16. 5 removable sockets \varnothing 1,5 mm for crimp termination \approx 16.</p>	 <p>8140-5026 3,8 g 5 broches démontables \varnothing 1,5 mm à sertir \approx 16. 5 removable sockets \varnothing 1,5 mm for crimp termination \approx 16.</p>	 <p>8140-1069 2,4 g 8 douilles \varnothing 1 mm démontables à sertir \approx 20. 8 removable sockets \varnothing 1 mm for crimp termination \approx 20.</p>	 <p>8140-631 Module de remplissage sans contacts. Single module without contact.</p>



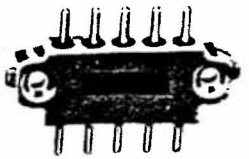
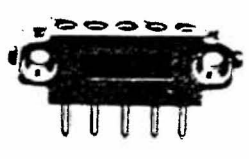

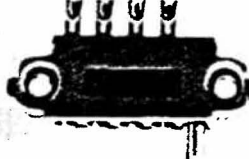
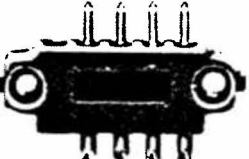
CONNECTRAL 8140 series

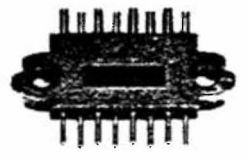

Éléments simples (suite)

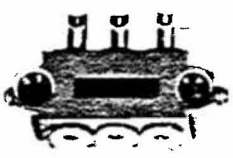
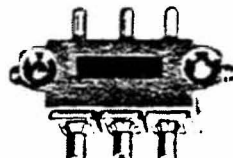
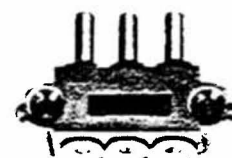
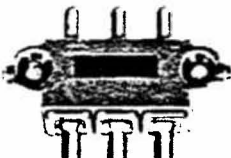
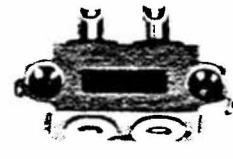
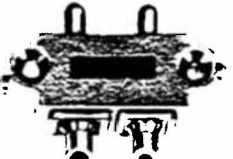
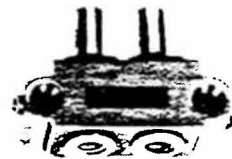
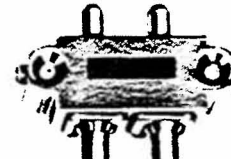
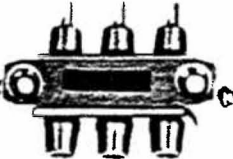
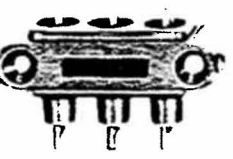
 <p>8140-05 3.8 g 5 broches doubles \varnothing 1.5 mm (intermédiaire). 5 double pins \varnothing 1.5 mm (intermediate piece).</p>	 <p>8140-16 3.4 g 5 contacts mixtes \varnothing 1.5 mm (intermédiaire). 5 mixed contacts \varnothing 1.5 mm (intermediate piece).</p>	 <p>8140-19 4.2 g 5 queues doubles a souder 1.5 mm. 5 double solder connectors \varnothing 1.5 mm.</p>	
 <p>8140-25 3 g 4 douilles \varnothing 1.5 mm a souder et un detrompeur. 4 sockets \varnothing 1.5 mm solder connection (for identification coding).</p>	 <p>8140-26 3.6 g 4 broches \varnothing 1.5 mm a souder et codage. 4 pins \varnothing 1.5 mm solder connection (for identification coding).</p>	 <p>8140-780 2.4 g 8 douilles demontables \varnothing 1 mm a sertir \times 20. 8 removable sockets \varnothing 1 mm crimp termination \times 20.</p>	 <p>8140-779 3.3 g 8 broches demontables \varnothing 1 mm a sertir \times 20. 8 removable pins \varnothing 1 mm crimp termination \times 20.</p>

Éléments doubles - Double width modules

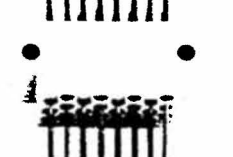
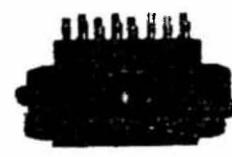
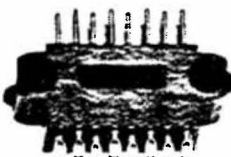
 <p>8140-06 5.8 g 3 douilles \varnothing 2.5 mm a souder \times 13 max. 3 sockets \varnothing 2.5 mm solder connection \times 13 max.</p>	 <p>8140-07 8.1 g 3 broches \varnothing 2.5 mm a souder \times 13 max. 3 pins \varnothing 2.5 mm solder connection \times 13 max.</p>	 <p>8140-08 6.1 g 3 douilles \varnothing 2.5 mm a sertir \times 13 max. 3 sockets \varnothing 2.5 mm crimp connection \times 13 max.</p>	 <p>8140-09 8.3 g 3 broches \varnothing 2.5 mm a sertir \times 13 max. 3 sockets \varnothing 2.5 mm crimp connection \times 13 max.</p>
 <p>8140-11 5.9 g 2 douilles 3.5 mm a souder \times 8 max. 2 sockets 3.5 mm solder connection \times 8 max.</p>	 <p>8140-12 8.4 g 2 broches 3.5 mm a souder \times 8 max. 2 pins 3.5 mm solder connection \times 8 max.</p>	 <p>8140-13 6.1 g 2 douilles 3.5 mm a sertir \times 8 max. 2 sockets 3.5 mm crimp connection \times 8 max.</p>	 <p>8140-14 8.8 g 2 broches 3.5 mm a sertir \times 8 max. 2 pins 3.5 mm crimp connection \times 8 max.</p>
 <p>8140-60 4.8 g 3 douilles 1.5 mm a souder (haute tension) \times 18 max. 3 sockets \varnothing 1.5 mm solder connector (High voltage) \times 18 max.</p>	 <p>8140-59 3.8 g 3 broches 1.5 mm a souder (haute tension) \times 18 max. 3 pins \varnothing 1.5 mm solder connection (High voltage) \times 18 max.</p>	 <p>8140-1020 5.8 g 2 douilles haute tension 5.8 g 2 high voltage sockets</p>	 <p>8140-1019 6.1 g 2 broches haute tension 6.1 g 2 high voltage pins.</p>
 <p>8140-1042 8.7 g 24 douilles \varnothing 1 mm mini wire wrap. 24 sockets \varnothing 1 mm for mini wire wrap termination</p>	 <p>8140-1041 10.9 g 24 broches \varnothing 1 mm mini wire wrap. 24 pins \varnothing 1 mm for mini wire wrap termination.</p>	 <p>8140-118 9 g 24 douilles a souder \times 20 max. 24 sockets with solder termination \times 20 max</p>	 <p>8140-117 12 g 24 broches a souder \times 20 max. 24 pins with solder termination \times 20 max.</p>



CONNECTRAL 8140 series





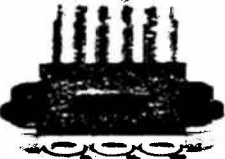
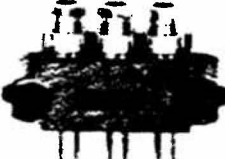

Éléments coaxiaux - Coaxial modules

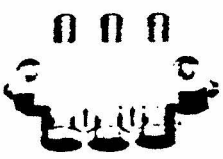
Référence Part N°	Nombre de contacts Number of contacts	Largeur Module width	Matière de l'isolant Insulator material	Câbles spécification		Référence Part N°	Nombre de contacts Number of contacts	Largeur Module width	Matière de l'isolant Insulator material	Câble spécification	
				CCTU	MIL					CCTU	MIL
8140-129A	3 broches 3 Pins	Double	Alliage Alloy	KX21A	RG178BU	8140-791	2 broches 2 pins	Double	Alliage Alloy	KX15	RG58CU
8140-130A	3 douilles 3 sockets	Double	Alliage Alloy	KX21A	RG178BU	8140-792	2 douilles 2 sockets	Double	Alliage Alloy	KX15	RG58CU
8140-1016	3 broches 3 pins	Double	Plastic	KX22A	RG316U	8140-1130	2 douilles 2 sockets	Double	Plastic	KX21A	RG178BU
8140-1017	3 douilles 3 sockets	Double	Plastic	KX22A	RG316U	8140-1131	2 broches 2 pins	Double	Plastic	KX21A	RG178BU
8140-810	3 broches 3 pins	Double	Plastic	KX21A	RG178BU	8140-1140	2 douilles 2 sockets	Double	Plastic	KX22A	RG216U
40-811	3 douilles 3 sockets	Double	Plastic	KX21A	RG178BU	8140-1141	2 broches 2 pins	Double	Plastic	KX22A	RG216U
8140-812	2 broches 2 pins	Double	Plastic	KX15	RG58U	8140-123	1 broche 1 pin	Triple Treble	Alliage Alloy	KX15	RG58CU
8140-813	2 douilles 2 sockets	Double	Plastic	KX15	RG58U	8140-124	1 douille 1 socket	Triple Treble	Alliage Alloy	KX15	RG58CU

Éléments doubles - Double width module

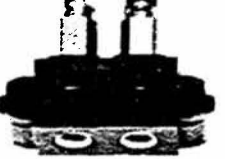
 <p>8140-811 11,8 g 3 douilles coaxiales 50 Ω. 3 × 50 Ω Coaxial sockets.</p>	 <p>8140-810 10,3 g 3 broches coaxiales 50 Ω. 3 × 50 Ω Coaxial pins.</p>	 <p>8140-129A 22,8 g 3 douilles coaxiales 50 Ω. 3 × 50 Ω Coaxial sockets.</p>	 <p>8140-130A 24,5 g 3 broches coaxiales 50 Ω. 3 × 50 Ω Coaxial pins.</p>
---	---	---	--

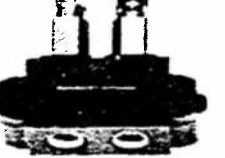
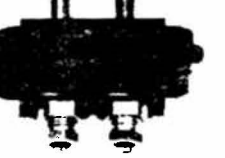
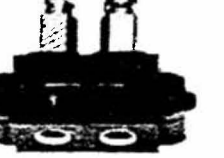
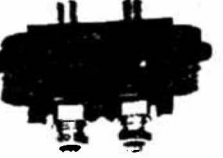

Éléments triples - Triple width module

 <p>8140-813 8,1 g 2 douilles coaxiales 50 Ω. 2 × 50 Ω Coaxial sockets.</p>	 <p>8140-812 7,1 g 2 broches coaxiales 50 Ω. 2 × 50 Ω Coaxial pins.</p>	 <p>8140-791 22,3 g 2 douilles coaxiales 50 Ω. 2 × 50 Ω Coaxial sockets.</p>	 <p>8140-792 29,2 g 2 broches coaxiales 50 Ω. 2 × 50 Ω Coaxial pins.</p>
 <p>8140-1130 8,1 g 2 douilles coaxiales 50 Ω. 2 × 50 Ω Coaxial sockets.</p>	 <p>8140-1131 7,1 g 2 broches coaxiales 50 Ω. 2 × 50 Ω Coaxial pins.</p>	 <p>8140-1140 8,1 g 2 douilles coaxiales 50 Ω. 2 × 50 Ω Coaxial sockets.</p>	 <p>8140-1141 7,1 g 2 broches coaxiales 50 Ω. 2 × 50 Ω Coaxial pins.</p>



CONNECTRAL 8140 series

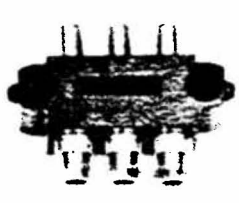

Éléments triples - Triple width module

 <p>8140-124 36,8 g 1 douille coaxiale 50 Ω. 1 × 50 Ω Coaxial socket.</p>	 <p>8140-123 33,2 g 1 broche coaxiale 50 Ω. 1 × 50 Ω Coaxial pin.</p>	 <p>8140-1017 11,8 g 3 douilles coaxiales 50 Ω. 3 × 50 Ω Coaxial pin.</p>	 <p>8140-1016 10,3 g 3 broches coaxiales 50 Ω. 3 × 50 Ω Coaxial socket.</p>
--	--	---	--

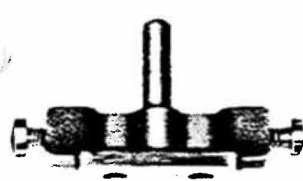
Équerres d'extrémité - End spacer

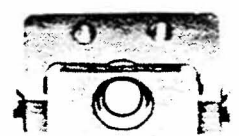
 <p>8140-20 2,5 g equerre d'extrémité polyamide avec guide mâle. Polyamide end spacer with guide pin.</p>	 <p>8140-21 2,2 g equerre d'extrémité polyamide avec guide femelle. Polyamide end spacer with female guide.</p>	 <p>8140-23 12,1 g equerre métallique avec guide pour prise de rack. Metal end spacer with guide pin for rack connector.</p>	 <p>8140-24 11,9 g ensemble glissière métallique pour prise de rack. Metal end spacer with floating guide hole assembly for rack.</p>
--	--	--	--

Rail - Side channel

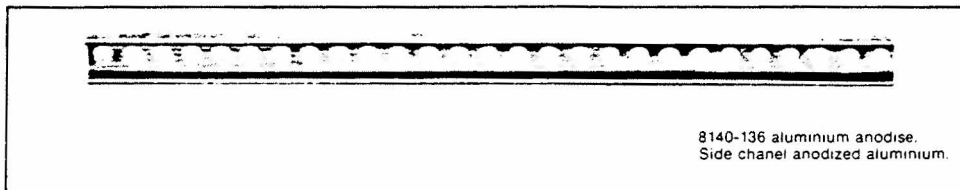

Capot - Hood

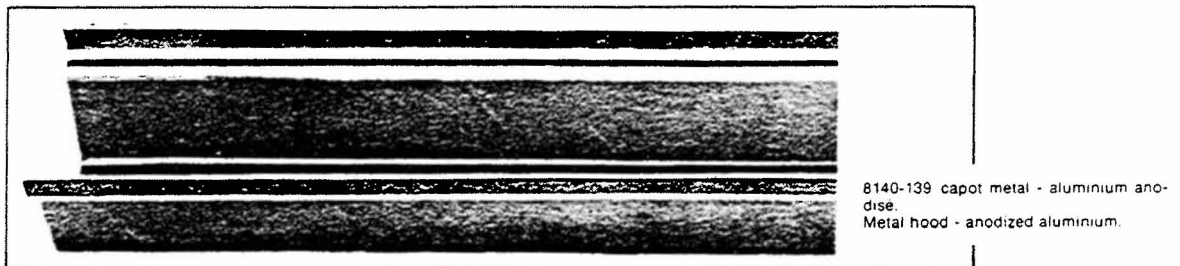

Équerres de capot - Hood end pieces

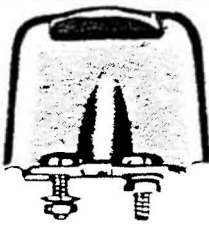
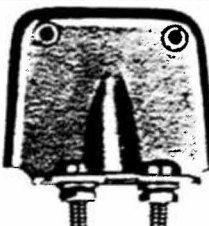
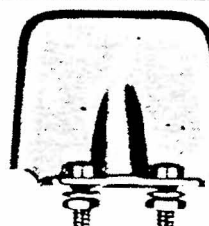
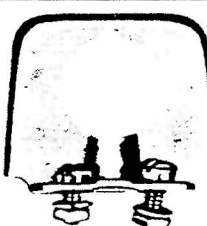
 <p>8140-41 11,2 g detourée avec pattes - With lug</p>	 <p>8140-44 9 g detourée sans patte sur cloison 9 g with cut out for panel mounting</p>	 <p>8140-65 8,7 g detourée pour 3,4, 5 éléments simples. Hood end piece 3,4, 5 single modules</p>	 <p>8140-74 7,2 g ajourée sortie Ø 12 mm With hole for cable clamps 12</p>
---	--	---	---



CONNECTRAL 8140 series



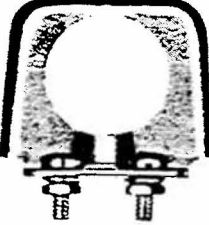
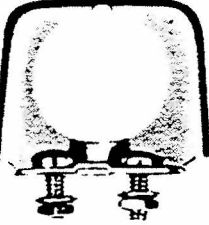
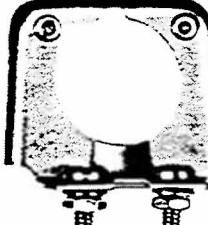
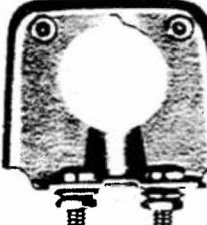

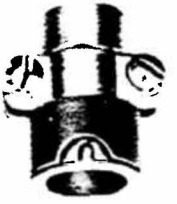

Équerres de capot - Hood end pieces

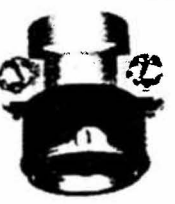
 <p>8140-75 7.1 g ajourée sortie \varnothing 14.5 mm. With hole for cable clamp 14.5 \varnothing.</p>	 <p>8140-96 6.9 g ajourée sortie \varnothing 16 mm. With hole for cable clamp 16 \varnothing.</p>	 <p>8140-98 7.2 g sur cloison sortie \varnothing 14.5 mm. For panel mounting 14.5 \varnothing.</p>	 <p>8140-99 7.7 g sur cloison sortie \varnothing 12 mm. For panel mounting 12 \varnothing.</p>
--	--	--	---







Sorties à serre-câble - Cable clamps

 <p>8140-30 6.3 g \varnothing intérieur 14.5 mm. Internal \varnothing 14.5 mm.</p>	 <p>8140-39 5.5 g \varnothing intérieur 12 mm. Internal \varnothing 12 mm.</p>	 <p>8140-42 6 g réduit ovale - Oval section.</p>	 <p>8140-89 9 g \varnothing intérieur 16 mm. Internal \varnothing 16 mm.</p>
---	---	--	---

Capots nylon - Nylon hood

 <p>8140-31 1.8 g ressort de verrouillage avec plaque. Locking spring (with plate).</p>	 <p>8140-259 1.8 g équerre et doigt de verrouillage.</p>	 <p>8140-293 8.8 g Locking clip and locking arm.</p>	 <p>8140-325 1.9 g patte de guidage pour capot nylon. Guide plate for nylon cover.</p>
--	---	--	---

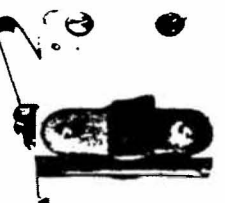
Verrouillage - Locking pieces

 <p>8140-48 9.4 g pour 1 élément simple avec verrouillage. For 1 single module (with locking).</p>	 <p>8140-49 11.5 g pour 2 éléments simples ou 1 double avec verrouillage - For 2 single modules or 1 double (with locking).</p>	 <p>8140-55 7.2 g pour 1 élément simple (sans verrouillage). For 1 single module (without locking).</p>	 <p>8140-56 9.5 g pour 2 éléments simples ou 1 double (sans verrouillage) - For 2 single modules or 1 double (without locking).</p>
 <p>8140-120 11.3 g pour 1 élément simple (avec verrouillage et guidage) - For 1 single module (with locking spring and retainer)</p>	 <p>8140-121 13.4 g pour 2 éléments simples ou 1 double (avec verrouillage et guidage) - For 2 single modules or 1 double (with locking spring and retainer).</p>	 <p>8140-246 Bande d'accrochage - Locking strip.</p>	

CONNECTRAL 8140 series



Extracteurs Extractors

Fichiers 8.42 8.44 8.42 8.44 Connectors

8140-35 8.8 g partie femelle - Female part.
8140-34 27.4 g partie mâle - Male part.
39033 Passe-fil - Grommet.

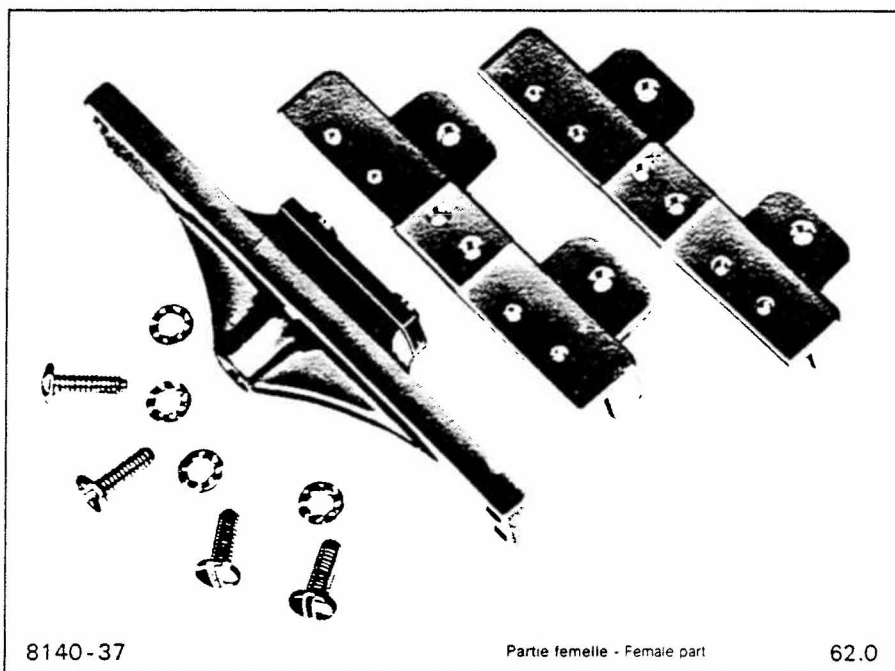
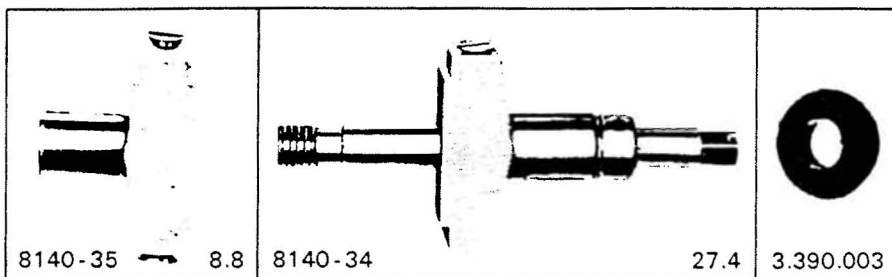



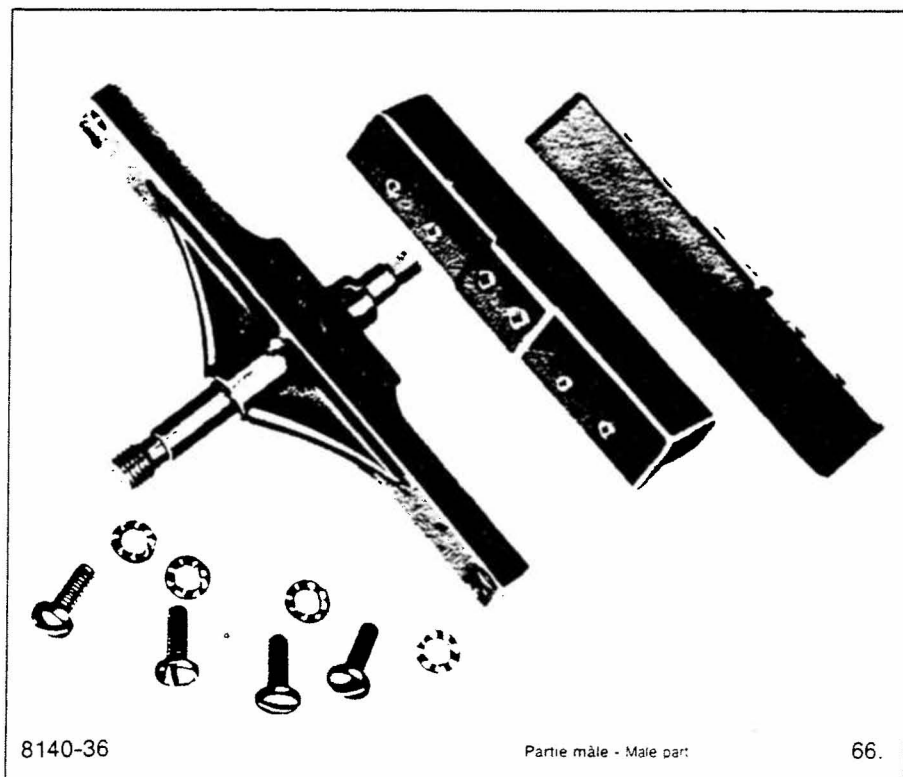





Fichier 8.43 8.43 Connector









CONNECTRAL 8140 series



Contacts

 8140-274	 8140-279	 8140-362	 8140-364	 8140-271
		 8140-278	 8140-361	 8140-363A U7

- 8140-274 2.1 g broche - pin \varnothing 3.5 mm
- 8140-279 0.7 g douille - socket \varnothing 3.5 mm
- 8140-362 1 g embout - solder bucket for 3.5 mm contacts
- 8140-364 1.1 g embout a sertir - crimp bucket for 3.5 mm contacts
- 8140-271 1.2 g broche - pin 2.5 mm
- 8140-278 0.4 g double - socket \varnothing 2.5 mm
- 8140-361 0.6 g embout a souder - solder bucket for 2.5 mm contacts
- 8140-363 0.7 g embout a sertir - crimp bucket for 2.5 mm contacts

 8140-725 <i>8140-4415</i>	 8140-726 <i>8140-6405</i>	 8140-855	 8140-856	 8140-858 <i>8140 4210</i>	 8634-115
---	---	---	---	---	---

- 8140-725 0.68 g broche a sertir \varnothing 1.5 mm - 1.5 mm \varnothing crimp pin for cable 16 AWG
- 8140-726 0.46 g douille a sertir \varnothing 1.5 mm - 1.5 mm \varnothing crimp socket for cable 16 AWG
- 8140-855 0.66 g broche a sertir \varnothing 1.5 mm - 1.5 mm \varnothing crimp pin for cable 24 AWG

- 8140-856 0.39 g douille a sertir \varnothing 1.5 mm - 1.5 mm \varnothing crimp socket for cable 24 AWG
- 8140-858 0.31 g broche a sertir \varnothing 1 mm - 1 mm \varnothing crimp pin
- 8140-115 0.23 g douille a sertir \varnothing 1 mm - 1 mm \varnothing crimp socket

Encombrement capots plastiques Dimensions of nylon hoods

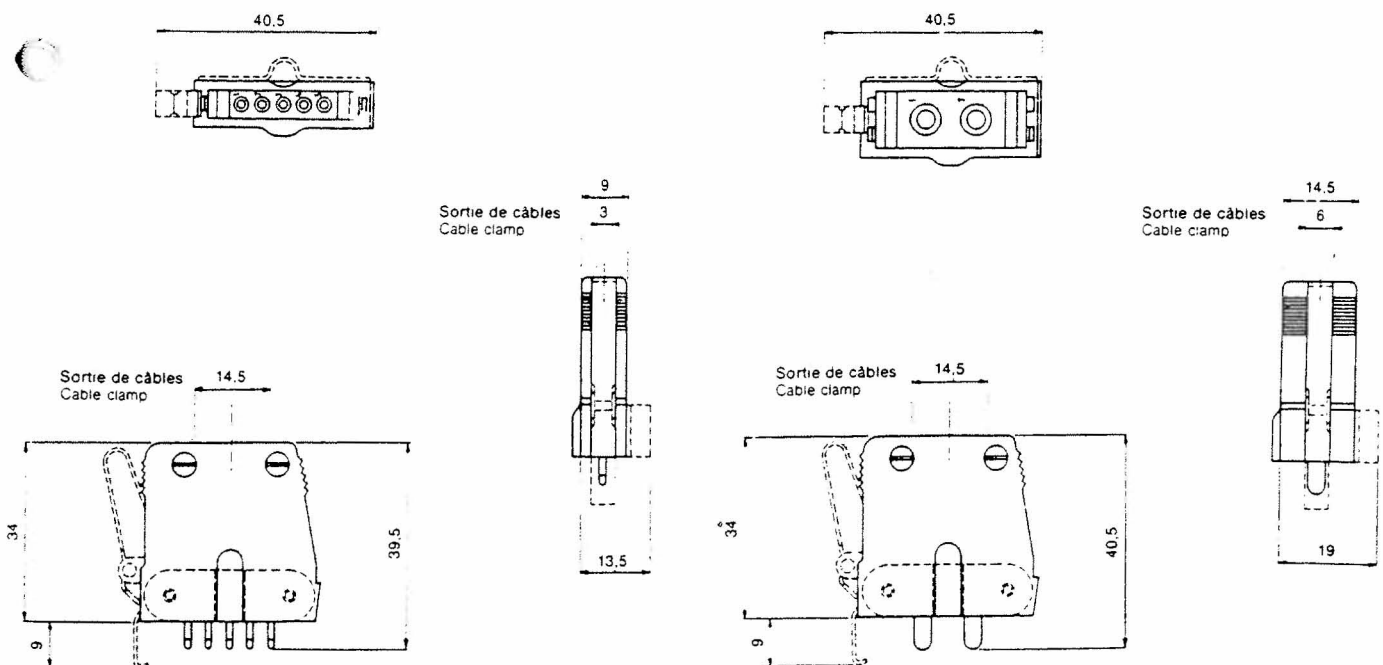

CONNECTRAL 8140 series



Sectionneur de masse - Earthing connectors

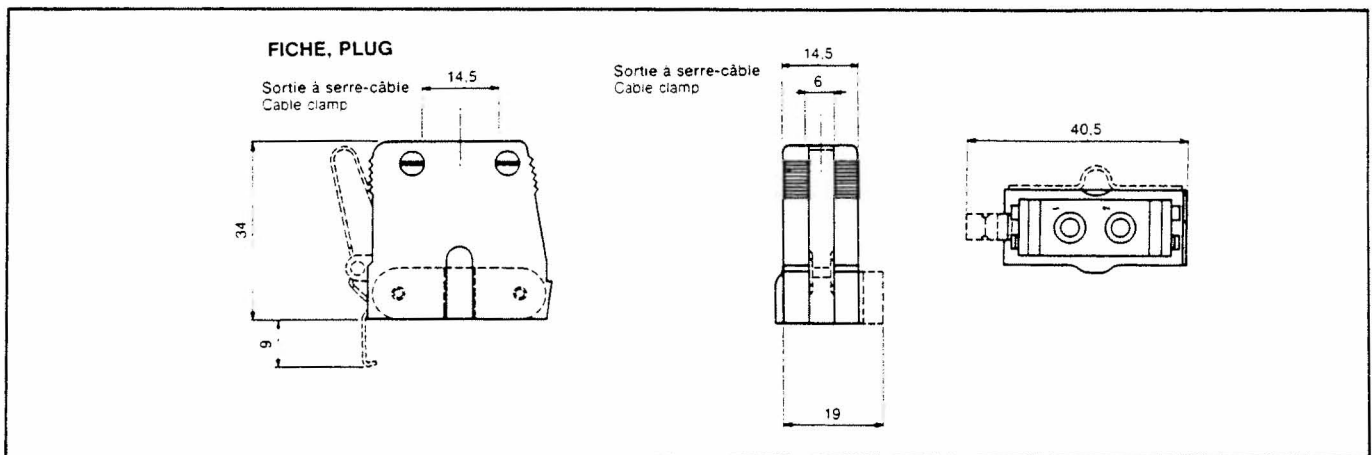
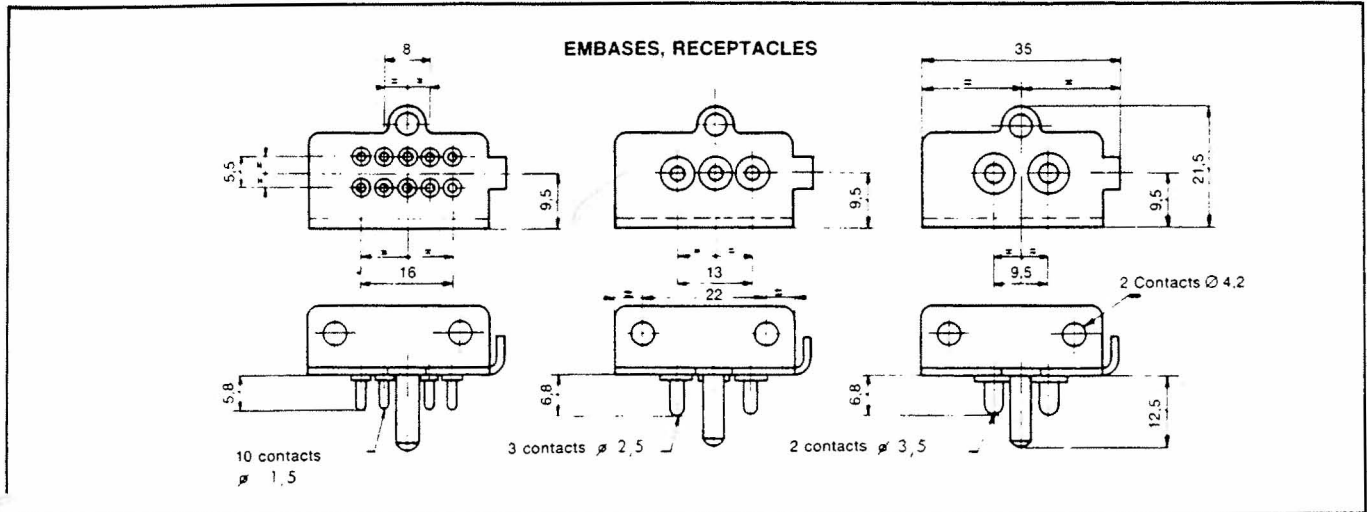

Sectionneurs de masse ou négatifs 50 A maxi comprenant :
une embase mâle métallique cadmée, bichromatée, pour fixation directe
sur structure et une fiche femelle composée d'éléments amovibles.

Connectors for earthing up to 50 AMP maximum comprising:
a male receptacle (cadmium plated metal bichromated) for direct fixing
on the structure, and a female plug made of removable modules.

Cette fiche peut comprendre :
2 éléments à 5 contacts femelles
ou 1 élément à 3 contacts femelles
ou 1 élément à 2 contacts femelles

1.5 mm
2.5 mm
3.5 mm

This plug consists of:
2 females modules with 5 contacts
or 1 female module with 3 contacts
or 1 female module with 2 contacts

1.5 mm
2.5 mm
3.5 mm

REFERENCES					Nombre de contacts Number of contacts		
Embase fixe (mâle) Receptable (male)	Masse Weight	Fiche mobile femelle - Plug (free) female	*Masse Weight g	Éléments montés dans la fiche femelle. Modules mounted in the female plug	1.5	2.5	3.5
8140-50/1	12.7	8140-200-553/1	18.5	8140-105	10		
8140-51	14.1	8140-000-215/A	18.5	8140-13			2
8140-54	13.4	8140-000-214/A	19	8140-08		3	

CONNECTRAL 8140 series



Encombrement des éléments Dimensions of modules

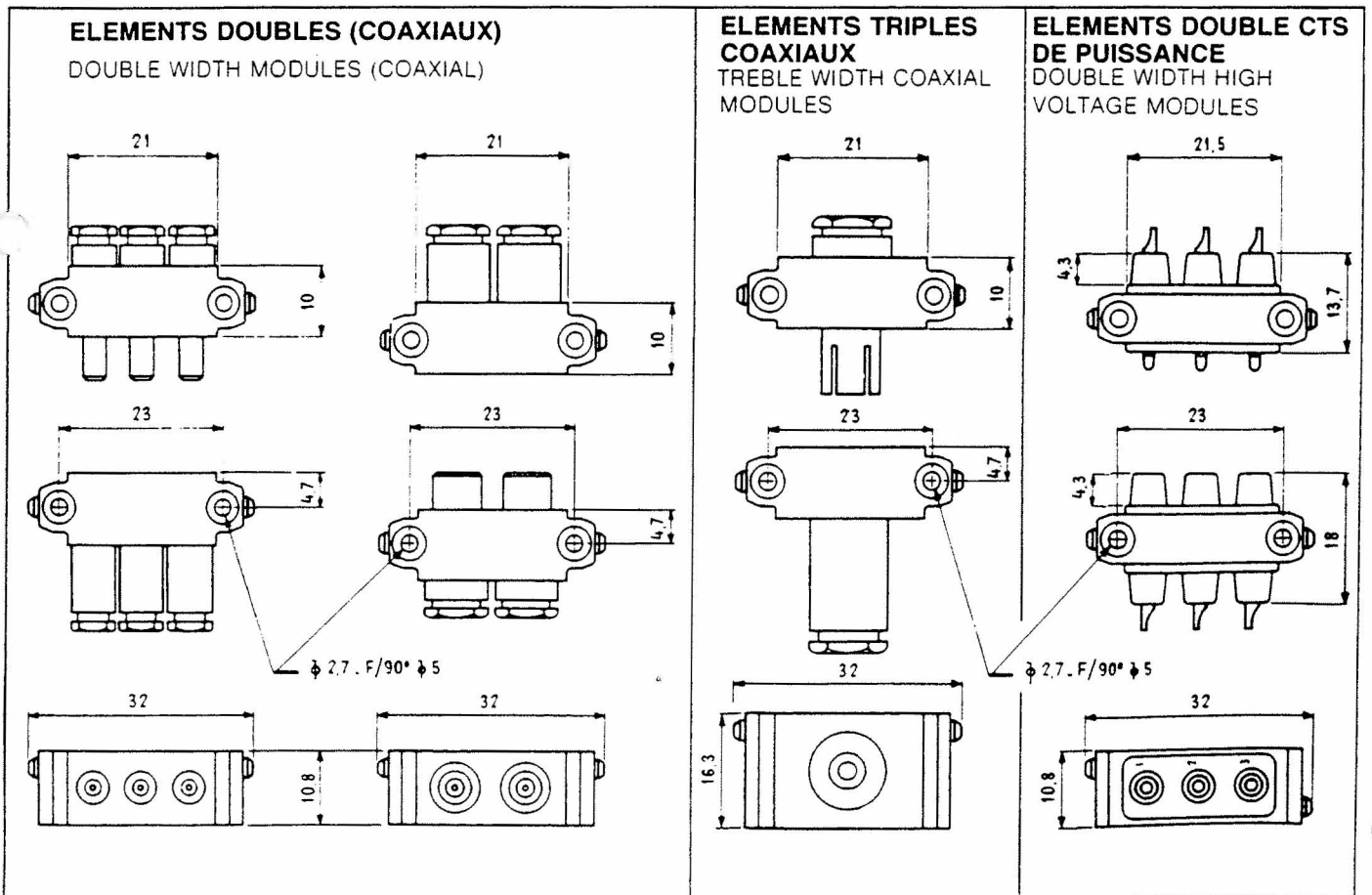
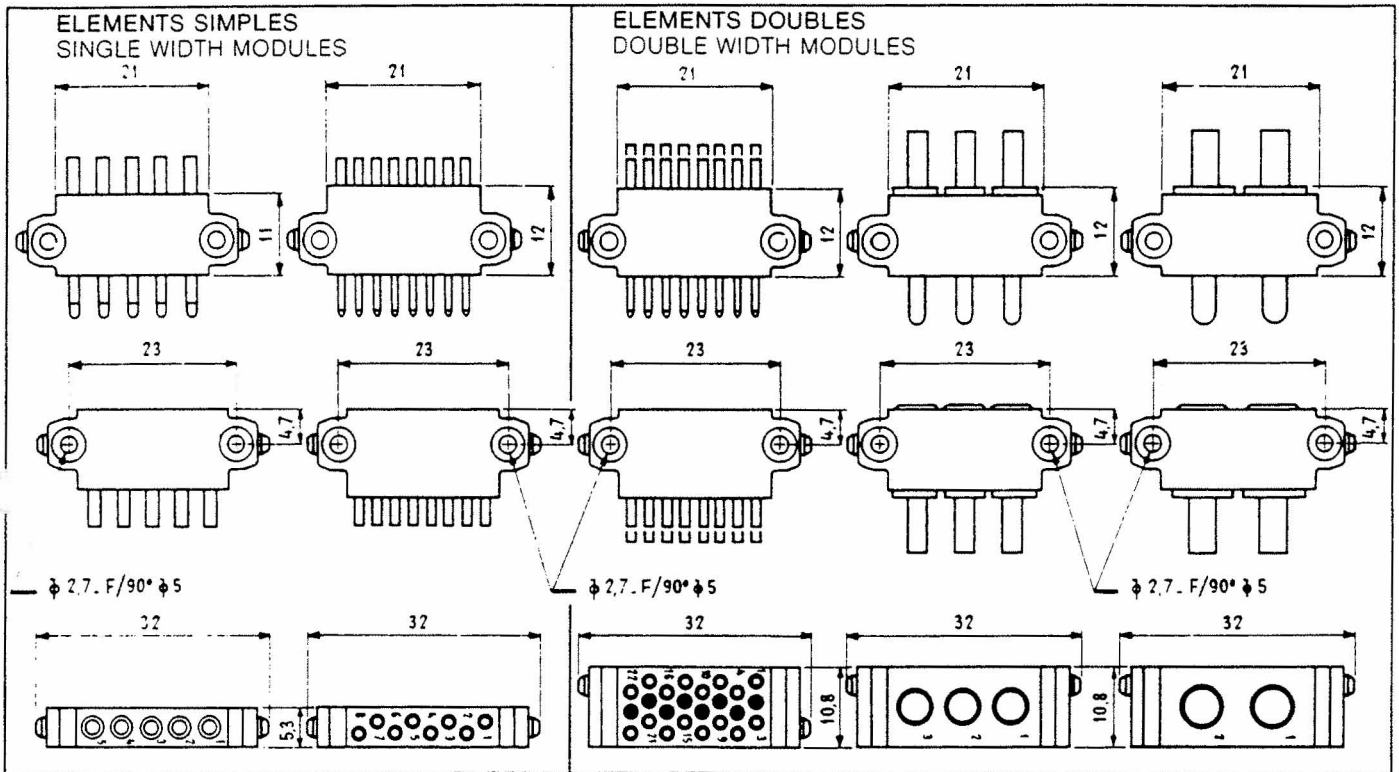

CONNECTRAL 8140 series



Encombrement des fichiers standards 8-40 Dimensions of 8-40 standard connectors

Formules de calcul (en mm)
Dimensions formulae (in mm)

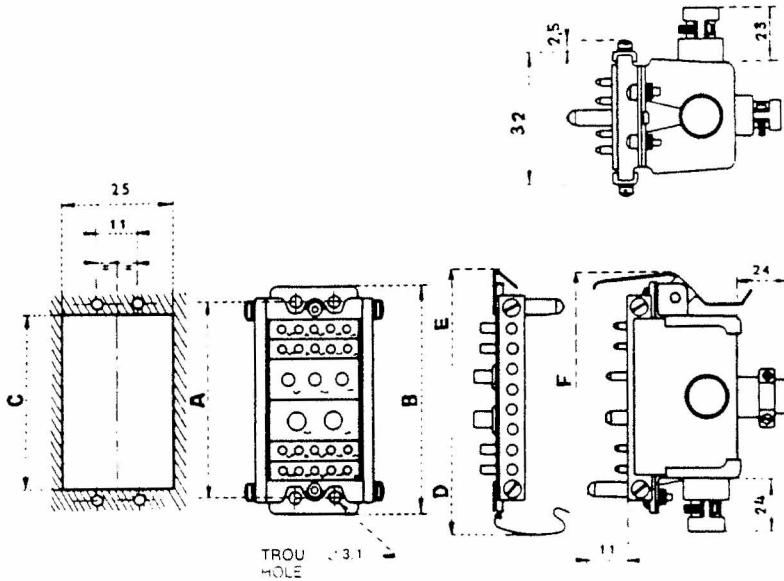

n1 Nombre d'éléments largeur 5,5 (éléments simples)
Number of modules width 5.5 (single modules)

n2 Nombre d'éléments largeur 11 (éléments doubles)
Number of modules width 11 (double modules)

n3 Nombre d'éléments largeur 16,5 (éléments triples)
Number of modules width 16.5 (triple modules)

A Entraxe
Distance between mounting centre
 $(5.5 n1 + 11 n2 + 16.5 n3) + 11$ constante

B $A + 7$ constante

C Ajourage cloison
Panel cutout
 $(5.5 n1 + 11 n2 + 16.5 n3) + 2$

D $B + 12$

Longueur du rail
Side channel length $(5.5 n1 + 11 n2 + 16.5 n3) + 10$

Longueur du capot
Hood length $(5.5 n1 + 11 n2 + 16.5 n3) - 1$

Nombre d'éléments simples larg. 5.5 Number of single modules width 5.5	1	2	3	4	5	6	7	8	9
A	16.5	22	27.5	33	38.5	44	49.5	55	60.5
B	23.5	29	34.5	40	45.5	51	56.5	62	67.5
C	7.5	13	18.5	24	29.5	35	40.5	46	51.5
D	35.5	41	46.5	52	57.5	63	68.5	74	77.5
E	29.5	35	40.5	46	51.5	57	62.5	68	73.5
Long. du rail Side channel length	15.5	21	26.5	32	37.5	43	48.5	54	59.5
Long. du capot Hood length			15.5	21	26.5	32	37.5	43	48.5
F			43.5	49	54.5	60	65.5	71	76.5

CONNECTRAL 8140 series



Encombrement des fichiers standards 8-40 Dimensions of 8-40 standard connectors

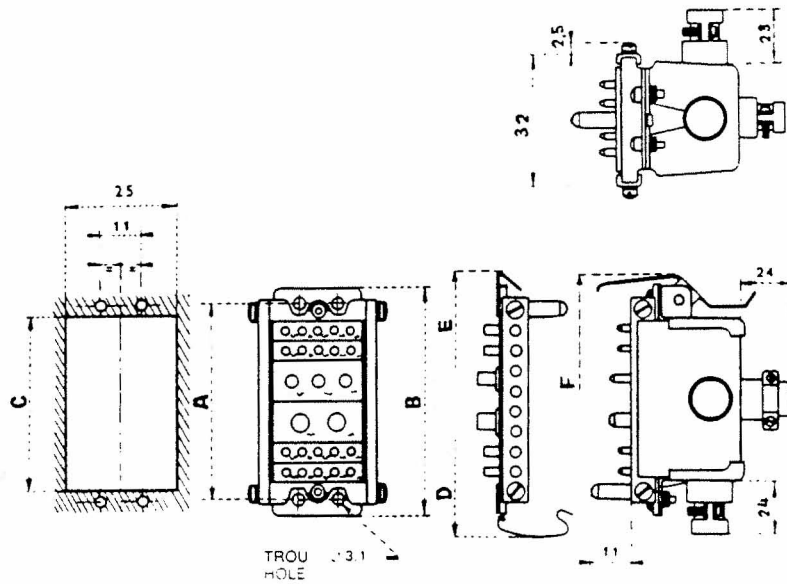

Formules de calcul (en mm)
Dimensions formulae (in mm)

- n1 Nombre d'éléments largeur 5.5 (éléments simples)
Number of modules width 5.5 (single modules)
- n2 Nombre d'éléments largeur 11 (éléments doubles)
Number of modules width 11 (double modules)
- n3 Nombre d'éléments largeur 16.5 (éléments triples)
Number of modules width 16.5 (triple modules)

- A Entraxe
Distance between mounting centre
(5.5 n1 + 11 n2 + 16.5 n3) + 11 constante
- B A + 7 constante
- C Ajourage cloison
Panel cutout
(5.5 n1 + 11 n2 + 16.5 n3) + 2
- D B + 12

Longueur du rail
Side channel length : (5.5 n1 + 11 n2 + 16.5 n3) + 10
Longueur du capot
Hood length : (5.5 n1 + 11 n2 + 16.5 n3) - 1

Nombre d'éléments simples larg. 5.5 Number of single modules width 5.5	1	2	3	4	5	6	7	8	9
A	16.5	22	27.5	33	38.5	44	49.5	55	60.5
B	23.5	29	34.5	40	45.5	51	56.5	62	67.5
C	7.5	13	18.5	24	29.5	35	40.5	46	51.5
D	35.5	41	46.5	52	57.5	63	68.5	74	77.5
E	29.5	35	40.5	46	51.5	57	62.5	68	73.5
Long. du rail Side channel length	15.5	21	26.5	32	37.5	43	48.5	54	59.5
Long. du capot Hood length			15.5	21	26.5	32	37.5	43	48.5
F			43.5	49	54.5	60	65.5	71	76.5

CONNECTRAL 8140 series



Encombrement des fichiers 8-41 pour rack Dimensions of 8-41 rack connectors

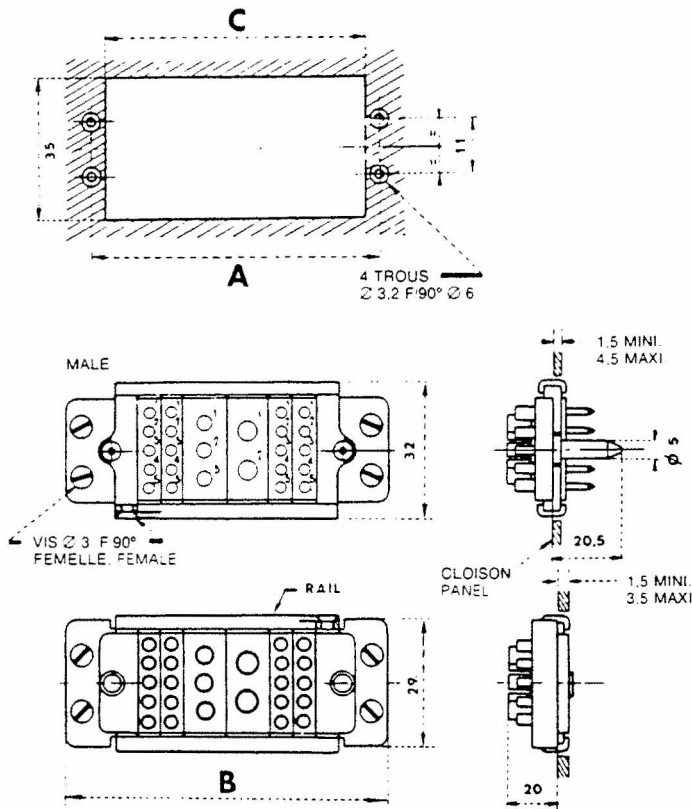

Formules de calcul (en mm)
Dimensional formulae (in mm)

- n1 Nombre d'éléments largeur 5,5 (éléments simples)
Number of modules width 5.5 (single modules)
- n2 Nombre d'éléments largeur 11 (éléments doubles)
Number of modules width 11 (double modules)
- n3 Nombre d'éléments largeur 16,5 (éléments triples)
Number of modules width 16.5 (triple modules)

- A Entraxe
Distance between mounting centre
 $(5,5 n1 + 11 n2 + 16,5 n3) + 11$ constante
- B $A + 7$ constante
- C Ajourage cloison
Panel cutout
 $(5,5 n1 + 11 n2 + 16,5 n3) + 2$

Longueur du rail
Side channel length : $(5,5 n1 + 11 n2 + 16,5 n3) + 2$

Longueur du capot
Hood length
 $(5,5 n1 + 11 n2 + 16,5 n3) - 1$

Nombre d'éléments simples larg. 5.5 Number of single modules width 5.5	1	2	3	4	5	6	7	8	9
A	36.5	42	47.5	53	58.5	64	69.5	75	80.5
B	43.5	49	54.5	60	65.5	71	76.5	82	87.5
C	29.5	35	40.5	46	51.5	57	62.5	68	73.5
Long. du rail Side channel length	17	22.5	28	33.5	39	44.5	50	55.5	61
Long. du capot Hood length			15.5	21	26.5	32	37.5	43	48.5

CONNECTRAL 8140 series



Encombrement des fichiers simples avec extracteur 8-42 Dimensions of 8-42 standard connectors with central extractor

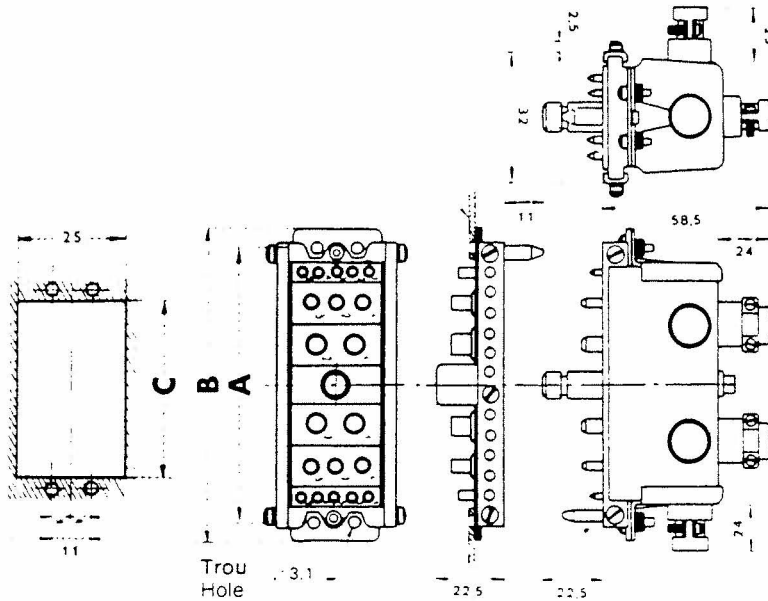

Formules de calcul (en mm)
Dimensional formulae (in mm)

n1 Nombre d'éléments largeur 5,5 (éléments simples)
Number of modules width 5.5 (single modules)

n2 Nombre d'éléments largeur 11 (éléments doubles)
Number of modules width 11 (double modules)

n3 Nombre d'éléments largeur 16,5 (éléments triples)
Number of modules width 16.5 (triple modules)

A Entraxe
Distance between mounting centre
 $(5,5 n1 + 11 n2 + 16,5 n3) + 11$
(extracteur - extractor) + 11 (constante)

B $A + 7$ (constante)

C Ajourage cloison
Panel cutout
 $(5,5 n1 + 11 n2 + 16,5 n3) + 11 + 2$

Longueur du rail
Side channel length : $(5,5 n1 + 11 n2 + 16,5 n3) + 11 + 10$

Longueur du capot
Hood length : $(5,5 n1 + 11 n2 + 16,5 n3) + 11 - 1$

Nombre d'éléments simples larg. 5.5 Number of single modules width 5.5	2	4	6	8	10	12	14	16
A	33	44	55	66	77	88	99	110
B	40	51	62	73	84	95	106	117
C	24	35	46	57	68	79	90	101
Long. du rail Side channel length	32	43	54	65	76	87	98	109
Long. du capot Hood length	21	32	43	54	69	76	87	98

CONNECTRAL 8140 series



Encombrement des fichiers doubles avec extracteur 8-43 Dimensions of 8-43 twin standard connectors with central extractor

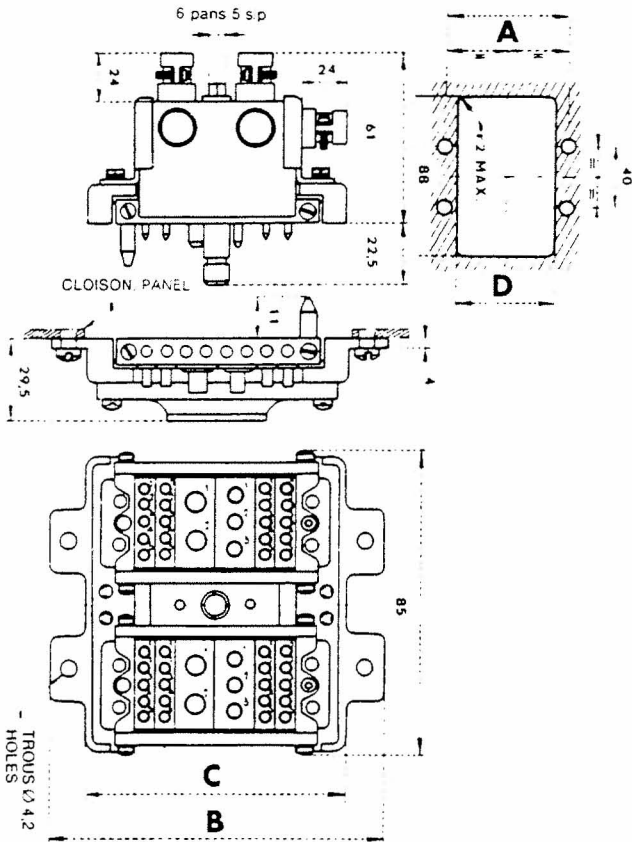

Formules de calcul (en mm)
Dimensional formulae (in mm)

n1 Nombre d'éléments largeur 5,5 (éléments simples)
Number of modules width 5.5 (single modules)

n2 Nombre d'éléments largeur 11 (éléments doubles)
Number of modules width 11 (double modules)

n3 Nombre d'éléments largeur 16,5 (éléments triples)
Number of modules width 16.5 (triple modules)

A Entraxe
Distance between mounting centre
 $(5,5 n1 + 11 n2 + 16,5 n3) + 45$

B $A + 10$

C Ajourage cloison
Panel cutout
 $(5,5 n1 + 11 n2 + 16,5 n3) + 32$

Longueur du rail
Side channel length : $(5,5 n1 + 11 n2 + 16,5 n3) + 10$

Longueur du capot
Hood length : $(5,5 n1 + 11 n2 + 16,5 n3) - 1$

Nombre d'éléments simples dans un fichier simple Number of single modules in a single connector	7	8	9	10	11	12	13	14	15	16
A	83.5	89	94.5	100	105.5	111	116.5	122	127.5	133
B	93.5	99	104.5	110	115.5	121	126.5	132	137.5	143
C	68.5	74	79.5	85	90.5	96	101.5	107	112.5	118
Long. du rail Side channel length	48.5	54	59.5	65	70.5	76	81.5	87	92.5	98
Long. du capot Hood length	37.5	43	48.5	54	59.5	65	70.5	76	81.5	87

CONNECTRAL 8140 series



Fichiers 8.44 pour rack avec extracteur 8.44 rack connectors with extractor

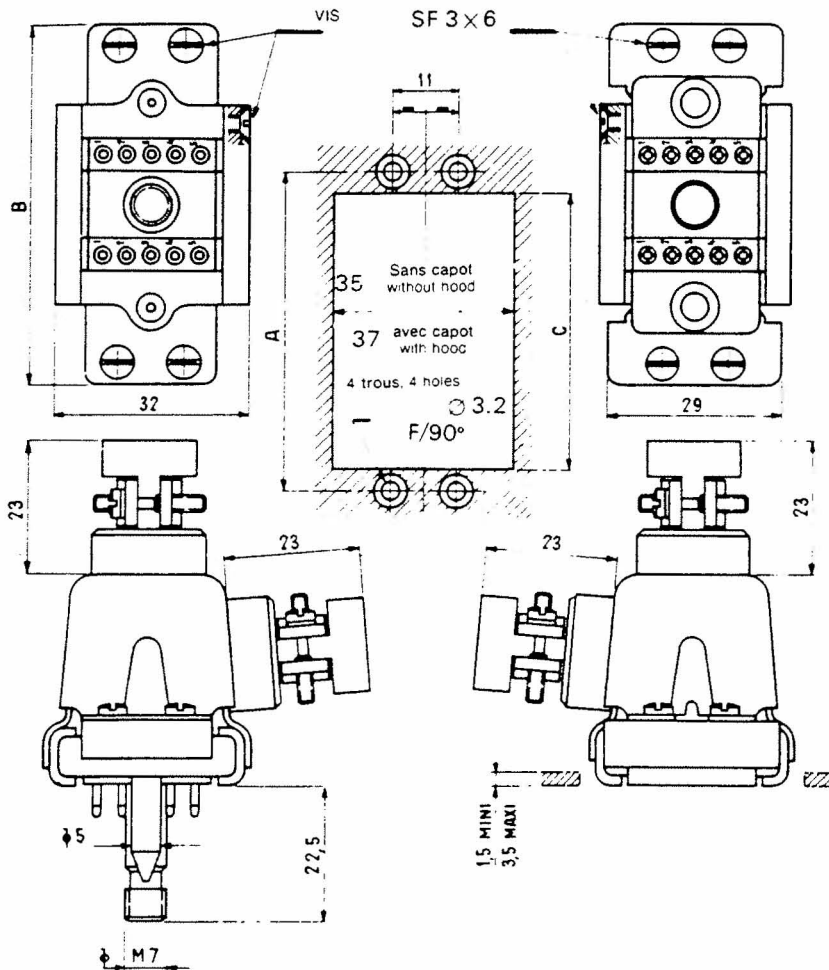

A : Entraxe. Distance between mounting centre (5,5 n1 + 11 n2 + 16,5 n3) + 11 (extracteur-extractor) + 31 (constante).

B : A + 7 (constante)

C : Ajourage cloison. Panel cutout (5,5 n1 + 11 n2 + 16,5 n3) + 11 + 24.

Longueur du rail - Side channel length (5,5 n1 + 11 n2 + 16,5 n3) + 11 + 11,5.

Longueur du capot - Hood length (5,5 n1 + 11 n2 + 16,5 n3) + 11 - 1

n1 Nombre d'éléments largeur 5,5 (éléments simples)
Number of modules width 5.5 (single modules)

n2 Nombre d'éléments largeur 11 (éléments doubles)
Number of modules width 11 (double modules)

n3 Nombre d'éléments largeur 16,5 (éléments triples)
Number of modules width 16.5 (triple modules)

Formule de calcul (en mm)
Calculation formulae (in mm)

Nombre d'éléments simples larg. 5.5 Number of single modules width 5.5	2	4	6	8	10	12	14	16
A	53	64	75	86	97	108	119	130
B	60	71	82	93	104	115	126	139
C	46	57	68	79	90	101	112	123
Long. du rail Side channel length	33.5	44.5	55.5	66.5	77.5	88.5	99.5	110.5
Long. du capot Hood length	21	32	43	54	65	76	87	98

CONNECTRAL 8140 series



Outillage - Tools

Pincès à sertir Crimping tools

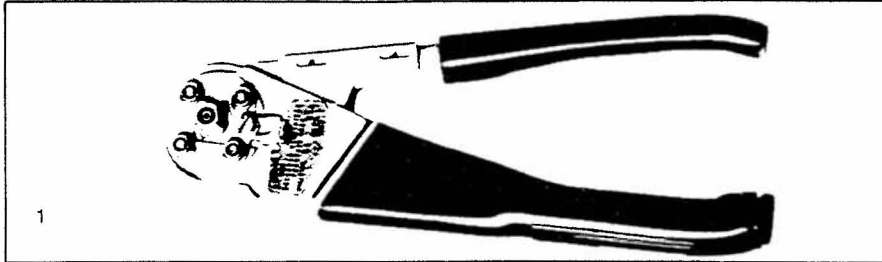

1 8465 (MS 3191-1) pour/for contacts 8140-4415-6405 Ø 1.5 mm Cable AWG 16.
Nous consulter pour le positionneur - Consult us for locator information.

2 8458 pour/for contacts Ø 1.5 mm, non démontables pour éléments simples n° 8140 104/105.
For 1.5 mm Ø no removable contacts for single elements n° 8140-104/105.

3 8459 pour/for contacts 8140-363/364 câbles admissibles 1,34 5,3 mm² - For contacts 8140-363/364 for cables from 1.34 to 5.3 mm².

4 Poinçon - Indenter part 8459-126.
Contacts 8140-364
Matrice - die part 8459-122

5 Poinçon - Indenter part 8459-127
Contacts 8140-363
Matrice - Die part 8459 124

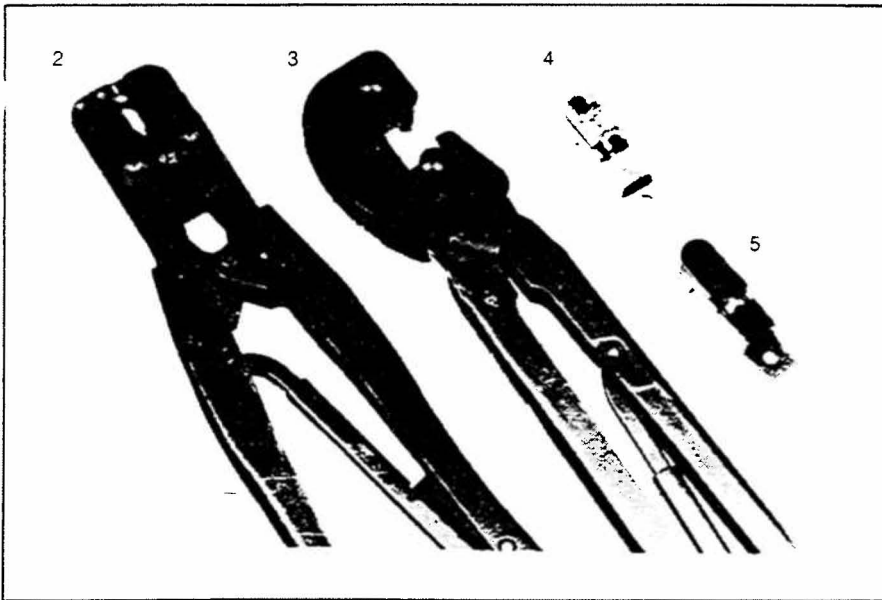

Outils d'insertion et d'extraction Insertion and extraction tools

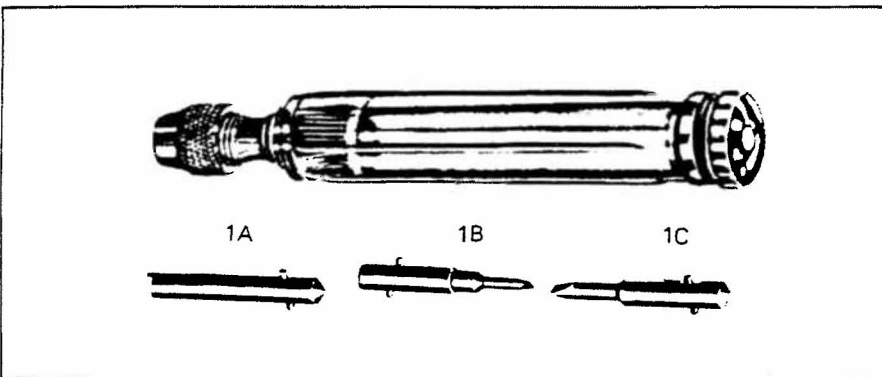

8140-82 Manche porte outil + démonteurs 1A 1B 1C pour contacts Ø 2,5 et 3,5 mm démontables.
Handle + tips 1A 1B 1C for 2.5 and 3.5 mm Ø removable contacts.

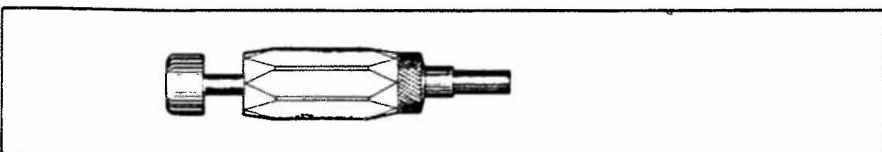

8140-574 Outil de démontage pour contacts éléments 8140-5027/5026.
Extraction tool for contacts of modules 8140-5027/5026.

8400 257 (+ 8140 208 (pias)
+ 8140 209 (co. ca. h))

Nous nous réservons le droit d'apporter à nos matériels toutes modifications que nous jugerons utiles dans un but d'amélioration. Les cotes portées dans nos catalogues sont donc susceptibles de subir de légères variations. Nous donnerons sur demande toutes cotes de détail nécessaires.

FCI reserves the right to make any engineering refinements, alterations or improvements deemed necessary on its products. The dimensions appearing in this catalogue are thus subject to change without notice. When dimensions are critical detailed drawings should be requested.

AUSTRALIA

FCI Connectors Australia
5 Tarrington Place
Smithfield NSW 2164
Tel.: 61 - 2 9725 5288
Fax: 61 - 2 9725 5204
e-mail: fciaus_sales@fciconnect.com

BELGIUM

FCI Belgium
48 A rue Stroobants
B-1140 Brussels
Tel.: 32 - 2 247 99 00
Fax: 32 - 2 247 99 99
e-mail: belgium@fciconnect.com

BRASIL

FCI Brasil
Estrada do Guarapiranga 2400
Santo Amaro
04901-905 SÃO PAULO-SP
Tel.: 55 - (11) 55 15 7200
Fax: 55 - (11) 55 15 7191
e-mail: brazil@fciconnect.com

CANADA

FCI Canada
1530 Birchmount Road
SCARBOROUGH - Ontario M1P 2G9
Tel.: 1 - (717) 767 8000
Fax: 1 - (717) 767 8052
e-mail: electronical.ca@fciconnect.com

CHINA

FCI Beijing
Unit 1412, Beijing COFCO Plaza Tower B
No. 8, Jianguomennei Daijie
Dong Cheng District
Beijing 100005, P.R. China
Tel.: 86 - 10 6526 3802
Fax: 86 - 10 6526 3805
e-mail: fcibj_sales@fciconnect.com

CHINA

FCI Hong Kong
AIA Tower New World Centre
20 Salisbury Road, Tsim Sha Tsui
Kowloon, Hong Kong
Tel.: 852 - 2510 8131
Fax: 852 - 2510 7743
e-mail: fcihk_sales@fciconnect.com

CHINA

FCI China
No. 808, Yong xin Mansion
Ji Mid Road
Shanghai 200020, P.R. China
Tel.: 86 - 21 6474 7807
Fax: 86 - 21 6467 4329
e-mail: fcisha_sales@fciconnect.com

CHINA

FCI Shenyang
No. 64-562, 8 Jing Street
Heping District, Shenyang 110003
P.R. China
Tel.: 86 - 24 2270 4873
Fax: 86 - 24 2270 4873
e-mail: fcisheny_sales@fciconnect.com

CHINA

FCI Shenzhen
Room 813A, 8/F, Shenzhen Kerry Centre
Renminan Lu, Shenzhen 518001
P.R. China
Tel.: 86 - 755 518 1732
Fax: 86 - 755 518 1730
e-mail: fcishenz_sales@fciconnect.com

FINLAND

FCI Finland Oy
Martinkuja 2
FIN-02270 ESPOO
Tel.: 358 9 86763611
Fax: 358 9 86763655
e-mail: ssarkkinen@fciconnect.com

FRANCE

FCI France
145 rue Yves le Coz
78035 VERSAILLES Cedex
Tel.: 33 - 1 39 49 21 83
Fax: 33 - 1 39 49 20 00
e-mail: fra@fciconnect.geis.com

GERMANY

Framatome Connectors Deutschland
Am Kronberger Hang 5
65824 Schwalbach
Tel.: 49 (0) 6196/9520-0
Fax: 49 (0) 6196/9520-111
e-mail: info_de@fciconnect.com

GREAT BRITAIN

Framatome Connectors UK
Connector House
Eyncourt Road - Woodside Estate
DUNSTABLE Beds. LU5 4TS
Tel.: 44 - 1 582 814 800
Fax: 44 - 1 582 814 814
e-mail: uk@fciconnect.com

INDIA

Framatome Connectors DEN
Thykoodam, Vyttila
Cochin 682 019 KERALA
Tel.: 91 - 484 303 028
Fax: 91 - 484 304 279
e-mail: fciindia_sales@fciconnect.com

INDONESIA

Framatome Connectors Indonesia
MEDCO Building, Ground Floor
Jl Ampera Raya, No. 20, Cilandak
Jakarta 12560
Tel.: 62 - 21 780 0824
Fax: 62 - 21 780 1560
e-mail: fciindo_sales@fciconnect.com

ITALY

Framatome Connectors Italia
Strada del Francese 137
10156 TORINO
Tel.: 39 - (011) 451 9611
Fax: 39 - (011) 470 2266
e-mail: italy@fciconnect.com

JAPAN

FCI Japan
28-10 Minami Oor 3-Chome
Shinagawa-ku, Tokyo 140-8581
Tel.: 81 - 3 5493 5200
Fax: 81 - 3 5493 5238
e-mail: fcijpn_sales@fciconnect.com

KOREA

FCI Korea
Room 301, Kyemyung Building 165-4
Samsung Dong, Kangnam Ku
Seoul 135090
Tel.: 82 - 2 562 8474
Fax: 82 - 2 562 8475
e-mail: fcikorea_sales@fciconnect.com

MEXICO

FCI Connectors Mexico
Calle 5 No. 104 Parque Industrial
Toluca 2000
C.P. 50200 Toluca
EDO DE MEXICO APDO Postal 532
Tel.: 52 - (72) 754 300
Fax: 52 - (72) 799 240
e-mail: fcim@edomex1.telmex.net.mx

NETHERLANDS

FCI Nederland
Essebaan 7
2908 LJ CAPELLE A/D IJSSEL
Tel.: 31 - 10 264 3333
Fax: 31 - 10 264 3399
e-mail: netherlands@fciconnect.com

SINGAPORE

FCI Asia
391B Orchard Road
18-00 Ngee Ann City
Singapore 238874
Tel.: 65 - 549 6600
Fax: 65 - 738 6311
e-mail: fcising_sales@fciconnect.com

SPAIN

FCI Connectors España
C/ Albert Einstein 5-7
Pol. Ind. Sesrovires
08635 St. Esteve Sesrovires
Tel.: 34 - (93) 771 5844
Fax: 34 - (93) 771 3197
e-mail: spain@fciconnect.com

SWEDEN

FCI Connectors Sweden
Sjöviksbacken 12
Box 47084 100 74 Stockholm
Tel.: 46 - (8) 685 5300
Fax: 46 - (8) 685 5355
e-mail: sweden@fciconnect.com

SWITZERLAND

FCI Schweiz
Sihlbruggstrasse 144
6340 BAAR
Tel.: 41 - (41) 760 1434
Fax: 41 - (41) 761 0647
e-mail: switzerland@fciconnect.com

TAIWAN

FCI Taiwan
No. 7-1 Tsa-Chiang 1st Road
Chung Li Industrial Zone
Chung Li, Taoyuan, Taiwan 320
Republic of China
Tel.: 886 - 3 452 4300
Fax: 886 - 3 451 5371
e-mail: fcitwn_sales@fciconnect.com

USA

FCI USA
825 Old Trail Road
Eiters, Pennsylvania 17319
Tel.: 1 - 800 237 2374
Fax: 1 - 717 938 7604
e-mail: uselectronics@fciconnect.com



www.fciconnect.com

X-ON Electronics

Largest Supplier of Electrical and Electronic Components

Click to view similar products for [High Speed/Modular Connectors](#) category:

Click to view products by [Sunbank](#) manufacturer:

Other Similar products are found below :

[650827-1](#) [74040-1346](#) [1410191-1](#) [1410368-3](#) [1410964-2](#) [1410326-3](#) [1410367-3](#) [1410971-4](#) [1467833-1](#) [2000877-1](#) [2000878-1](#) [2041314-1](#)
[2065387-1](#) [2187307-1](#) [163P](#) [1934290-1](#) [2000875-1](#) [2065917-1](#) [2102736-2](#) [FSR-40](#) [2169868-2](#) [22354-8](#) [437-5040-000](#) [5-1393565-0](#) [039-](#)
[0246-000](#) [0761601016](#) [0784461022](#) [10123159-12ELF](#) [030-2415-003/100 PK](#) [030-7380-004](#) [030-2494-001](#) [532939-1](#) [5532901-3](#) [3-1469268-](#)
[7](#) [74748-102LF](#) [73670-0247](#) [10041743-101LF](#) [10066670-100002LF](#) [1-533915-1](#) [249-4515-000](#) [7-1469373-3](#) [DL2-2J/S](#) [2000713-8](#)
[2000713-7](#) [10124313-101LF](#) [3011-21](#) [757105208](#) [EBTF-4-10-2.0-S-RA-1](#) [430305-001](#) [4395800100](#)