

84 Series

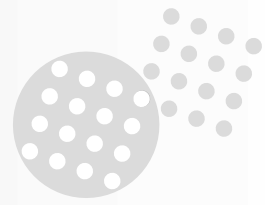

Presentation

The 84 bayonet series has been especially designed for light and harsh environment. Its physical characteristics and performances are appreciated in a large range of applications including :

- **Factory automation - Machine tool - Light electronics : 840 series**
- **Heavy transportation - Mining and harsh environment : 845 series**
- **Military Ground Equipment - Heavy weapons : 847 series**

Large variety of backshells



Wide range of wire gauges and current carrying capabilities

Wire sizes from 24 through 00 AWG can be accommodated. Contacts are rated from 7,5 amps up to 200 amps



84 Series



Series	840 Series	845 Series	847 Series
Shell material	Aluminium	Steel	Steel
Plating	Alodine 1200	Yellow cadmium olive green cadmium	White cadmium olive green cadmium
Endurance	500 cycles	500 cycles	500 cycles
Number of contacts	1 to 61 from Ø 1 to Ø 10 mm	1 to 61 from Ø 1 to Ø 10 mm	3 to 6 from Ø 1,5 to Ø 5 mm
Withstanding voltage	2000 Vrms	2800 Vrms	2000 Vrms
Current rating	7,5 A to 200 A (AWG 24 to AWG 00)	7,5 A to 200 A (AWG 24 to AWG 00)	16 A to 63 A
Protection class	IP 65 Hose proof protected against water jets from all directions	IP 68 Water tight	IP 67
Type of termination	Solder Crimp Straight spill	Solder Crimp	Crimp
Others	Straight spill contacts Ground contacts Plastic and metal backshells	Sealing grommet Gold plated contacts	Pilot contacts VDE contacts layouts

840 Series

845 Series

847 Series

840 Series



Applications

- Factory automation & machine tools
- Test & measurement instrumentation
- Transportation



Description

- A connector set consists of : a plug, a receptacle or in line receptacle, backshells & accessories
- A bayonet coupling system allows quick connection and disconnection of connectors
- A mechanical index is provided to guide housings for correct alignment and the insulators may be rotated at different angles to give a specific orientation to otherwise similar connectors.

Characteristics

Mechanical

- Shell : aluminium alloy and thermoplastic
- Plating : alodine
- Insulator : neoprene elastomer monobloc
- Contact : copper alloy
- Plating : silver or gold
- Endurance : 500 mating/unmating operations
- Contact retention : (for crimp version)
 - Ø 1 : 50 N Ø 3,5 : 100 N Ø 10 : 200 N
 - Ø 1,5 : 70 N Ø 5 : 150 N
 - Ø 2,5 : 80 N Ø 7 : 150 N

Electrical

- Test voltage : 2000 Vrms (except Ø 1 contact) : 1500 Vrms
- Contact resistance :
 - Ø 1 : ≤ 3 mΩ Ø 1,5 : ≤ 1,5 mΩ
 - Ø 2,5 : ≤ 0,6 mΩ Ø 3,5 : ≤ 0,35 mΩ
 - Ø 5 : ≤ 0,25 mΩ Ø 7 : ≤ 0,15 mΩ
 - Ø 10 : ≤ 0,08 mΩ
- Insulation resistance : ≥ 5000 MΩ (at 500 Vdc)
- Current rating :
 - Ø 1 : 7,5 A Ø 3,5 : 40 A Ø 10 : 200 A
 - Ø 1,5 : 11 A Ø 5 : 63 A
 - Ø 2,5 : 25 A Ø 7 : 120 A

Environmental

- Temperature range : -40°C +85°C
- Sealing : as per NFC 20010 - IP65
- Salt spray : as per NFC 20611 (48 hours)

Ordering information

basic series	840	21	1	3	0	•	••• XS
contact layout	(see next page)						
shell type	1	square flange receptacle					
	8	plug					
	5	cable connecting receptacle					
	9	flange mounted plug					
		(without backshell - shell size 1 to 5 with 001 specification only)					
contact type	1	male crimp					
	3	male solder or spill					
	5	female crimp					
	7	female solder or spill					
backshell	0	connector supplied without backshell					
	2	connector supplied with backnut					
orientation		blank : standard orientation					
	W or X	other orientations (see next page)					
specification		without specification : silver plated crimp or solder contact					
	001	gold plated crimp contacts + metal retainer ring					
	002	gold plated crimp contacts					
	SP2	gold plated solder contacts					
	004	silver plated spill contacts Ø 0.8 mm length : 8.50 mm					
	SP1	male connector with one longest contact					
	008	male connector with one longest contact and grounding plate					
	XS	X = indicates the number of large barrel crimp contacts Ø 1.5 mm to be delivered with the connector (see p 11)					

840 Series



Contact layouts and polarizations

Viewed from front face of male insulator

shell 1	3 Ø 1,5 11 ● * ▲	2 Ø 1,5 12	1 Ø 3,5 13 ■	7 Ø 1 19 ■		
	7 Ø 1,5 21 ● * ▲	1 Ø 1,5 2 Ø 2,5 22	3 Ø 2,5 23 ● *	4 Ø 2,5 24 ●	3 Ø 1,5 26	12 Ø 1 29 ■
	12 Ø 1,5 31 ● * ▲	3 Ø 3,5 32	4 Ø 3,5 33	2 Ø 3,5 4 Ø 1,5 34	1 Ø 10 35 □	19 Ø 1 39 ■
	19 Ø 1,5 41 ● * ▲	8 Ø 1,5 4 Ø 2,5 42	4 Ø 3,5 8 Ø 1,5 43	6 Ø 2,5 6 Ø 1,5 44	4 Ø 5 45	2 Ø 2,5 12 Ø 1,5 46
shell 5	37 Ø 1,5 51 ●	19 Ø 2,5 52	26 Ø 1,5 53	61 Ø 1 54 ■		
	4 Ø 7 65	<p>Available arrangements :</p> <ul style="list-style-type: none"> ■ crimp only (specification 002) □ solder only * in 008 ▲ spill contacts ● in SP1 <p><i>SP1 and 008 silver plated solder contacts only, the longest contact is always loaded in the cavity identified as 1 in insulator.</i></p>				

840 Series



Square flange receptacle type 1

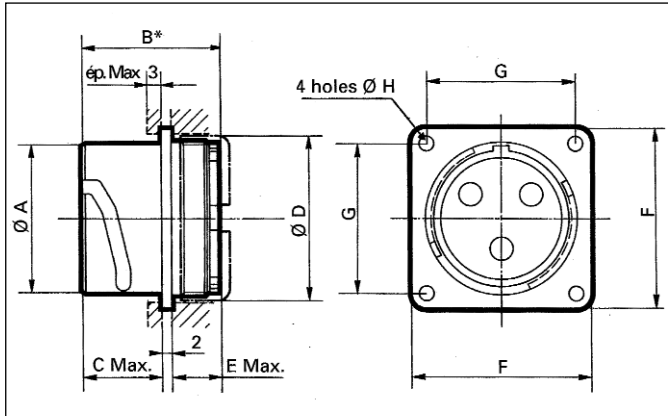

shells dim.	1	2	3	4	5	6
A	16 .63	20 .79	26 1.02	31 1.22	43 1.69	57 2.24
B*	27.50 1.08	27.50 1.08	27.90 1.10	27.90 1.10	39.10 1.54	39.10 1.54
C	16 .63	16 .63	17 .67	17 .67	17 .67	17 .67
D	18.50 .73	22.50 .89	27.50 1.08	33.50 1.32	44.50 1.75	61 2.40
E	12.50 .49	12.50 .49	12 .47	12 .47	23.50 .93	26 1.02
F	24 .94	27 1.06	31 1.22	37 1.46	49 1.93	66 2.60
G	18 .71	21 .83	25 .98	31 1.22	41 1.61	53 2.09
H	3.20 .13	3.20 .13	3.20 .13	3.20 .13	3.20 .13	5.50 .22

Panel cut-out

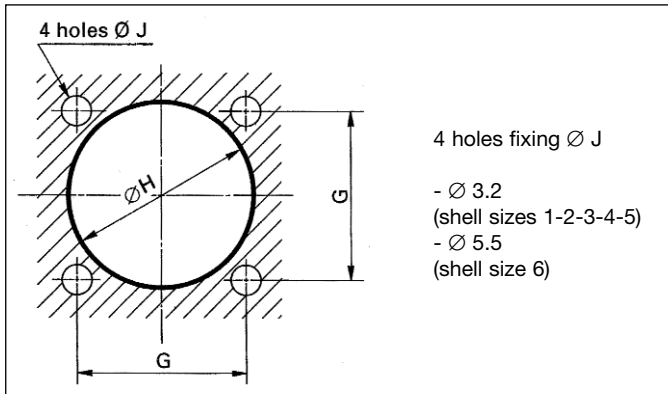

shells dim.	1	2	3	4	5	6
$G \pm 0,10$	18 .71	21 .83	25 .98	31 1.22	41 1.61	53 2.09
H	19.50 .77	23.50 .93	28.50 1.12	34.50 1.36	46 1.81	62 2.44

Flange mounted plug type 9

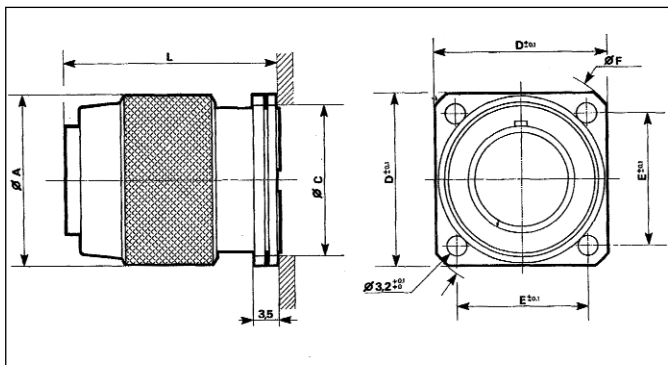

shells dim.	1	2	3	4	5
A	22.50 .89	26.50 1.04	33 1.30	39 1.54	51 2.01
L	32.50 1.28	32.50 1.28	32.50 1.28	32.50 1.28	43.50 1.71
C	19 .75	23 .91	28 1.10	34 1.34	45.50 1.79
D	24 .94	27 1.06	31 1.22	37 1.46	49 1.93
E	18 .71	21 .83	25 .98	31 1.22	41 1.61
F	31.50 1.24	36 1.42	41.50 1.63	50 1.97	64 2.52

Square flange receptacle type 1 with straight spills contacts

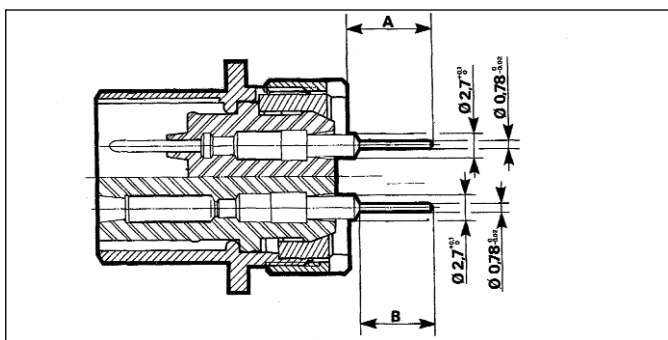

contact type	shells	A		$B^{+0,1}_0$
		min	Max.	
Long spills	1-2-3	9 .35	10.50 .41	8.50 .33
	4	9.50 .37	11 .43	

840 Series



Straight layout for arrangements 11-21-31 and 41

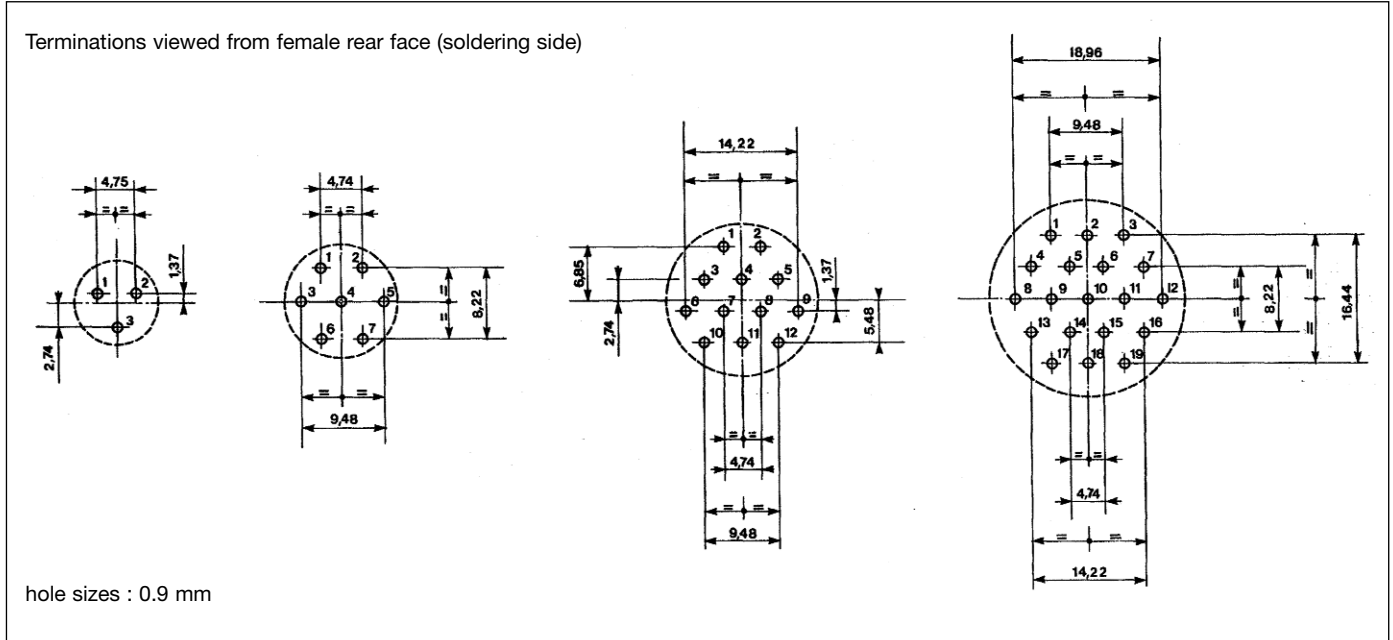

Dimensions

Plug type 8

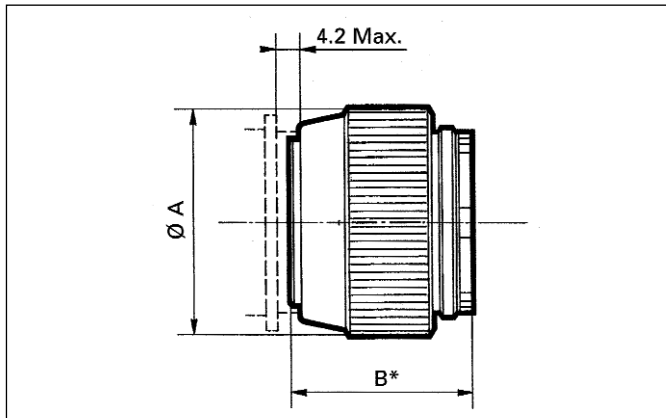

To calculate overall dimensioning of connector and backshell assembly, add the 2 dimensions B of each part.

Example :

Plug type 8 + backnut (002) shell size 1 = 31.5 + 2.5 = 34 mm

Receptacle type 1 + backnut (002) shell size 1 = 27.5 + 2.5 = 30 mm

B* includes retention cone

shells	1	2	3	4	5	6
dim.						
A	22.50 .89	26.50 1.04	33 1.30	39 1.54	51 2.01	65 2.56
B*	31.50 1.24	31.50 1.24	31.50 1.24	31.50 1.24	42.70 1.68	42.70 1.68

Cable connecting receptacle type 5

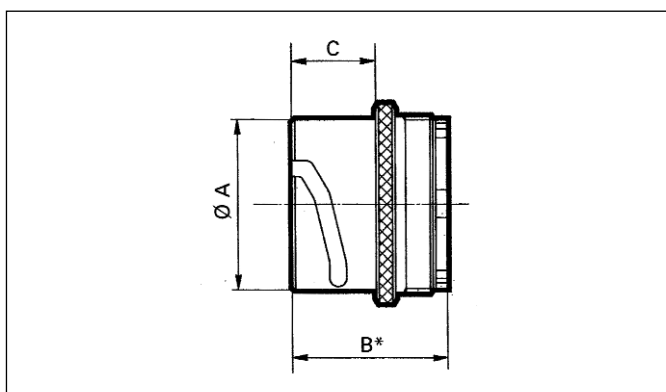

shells	1	2	3	4	5	6
dim.						
A	16 .63	20 .79	26 1.02	31 1.22	43 1.69	57 2.24
B*	27.50 1.08	27.50 1.08	27.90 1.10	27.90 1.10	39.10 1.54	39.10 1.54
C	14.50 .57	14.50 .57	15.50 .61	15.50 .61	15.50 .61	15.50 .61

840 Series



Backshells

basic series	840	2	0	002	...	
shell size	1	2	3	4	5	6
obligatory suffix						
backshell type	002	backnut				
	003	large outlet - straight metal backshells with cable clamp for crimp connector				
	004	standard outlet - elbow metal backshells with cable clamp for crimp connector				
	005	large outlet - elbow metal backshells with cable clamp for crimp connector				
	006	standard outlet - elbow metal backshells with cable clamp for crimp connector				
	008	plastic straight or angled backshell with cable clamp and sealing gland (shell sizes 1, 2, 3, 4, 5)				
	0010	metal straight backshell with cable clamp and sealing gland (shell sizes 2, 3, 4)				
	0011	metal straight backshell with sealing gland and threaded outlet (shell sizes 2, 3, 4)				
	0039	gaz thread adaptor (shell sizes 1, 2, 3, 4, 5)				
specification	indicates specification for backshell sealing gland diameter type 0010					

basic series	840	2	PEF	16														
shell size	1	2	3	4	5													
backshell type	electrical thread adaptor																	
thread type	<table border="1"> <thead> <tr> <th>shell</th> <th>1</th> <th>2</th> <th>3</th> <th>4</th> <th>5</th> </tr> </thead> <tbody> <tr> <td>PE type</td> <td>13</td> <td>16</td> <td>21</td> <td>21</td> <td>29</td> <td>29</td> </tr> </tbody> </table>					shell	1	2	3	4	5	PE type	13	16	21	21	29	29
shell	1	2	3	4	5													
PE type	13	16	21	21	29	29												

Electric thread adaptor

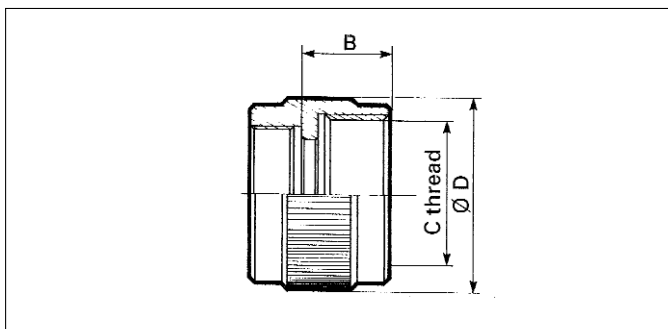

dim.	shells					
	1	2	3	4	5	
B Max.	18.70 .74	18.70 .74	19.30 .76	19.30 .76	18.70 .74	19.30 .76
C thread PE	13 .51	16 .63	21 .83	21 .83	29 1.14	29 1.14
D Max.	22.50 .89	26.50 1.04	33 1.30	43 1.69	43 1.69	51 2.01

840 Series



Gaz thread adaptor type 0039

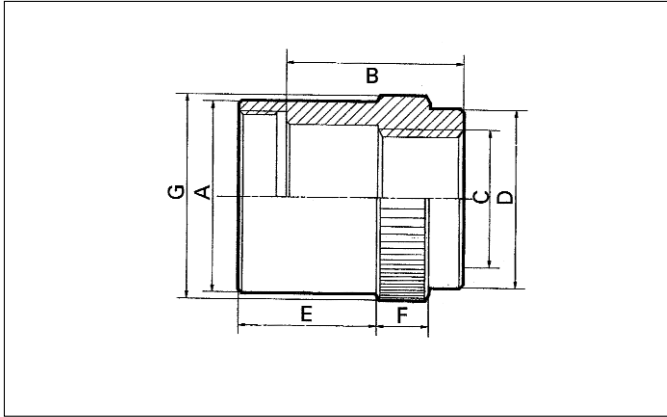

dim.	shells				
	1	2	3	4	5
A	19 .75	23 .91	29 1.14	35 1.38	46 1.81
B	15.50 .61	18 .71	21 .83	22 .87	31 1.22
C	G-1/4" 13.157	G-3/8" 16.662	G-1/2" 20.955	G-3/4" 26.441	G-1" 33.249
D	23.50 .93	22 .87	27 1.06	34 1.34	44 1.73
E	15 .59	17 .67	20 .79	25 .98	27.50 1.08
F	8 .31	8 .31	8 .31	8 .31	9 .35
G	24.50 .96	25 .98	31 1.22	37 1.46	48 1.89

Metallic backnut type 002

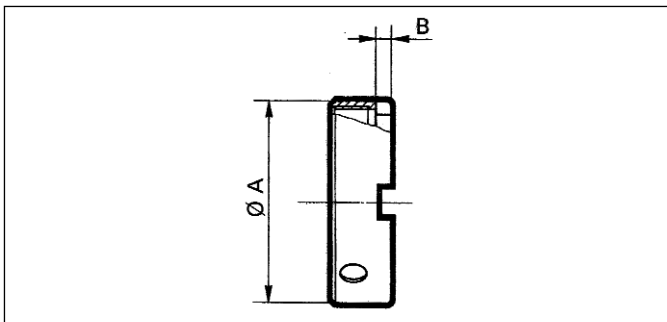

dim.	shells					
	1	2	3	4	5	6
A	18.50 .73	22.50 .89	27.50 1.08	33.50 1.32	44.50 1.75	61 2.40
B	2.50 .10	2.50 .10	2.50 .10	2.50 .10	2 .08	3 .12

Straight metal backshell with cable clamp type 003 and 004 depending on outlet Ø

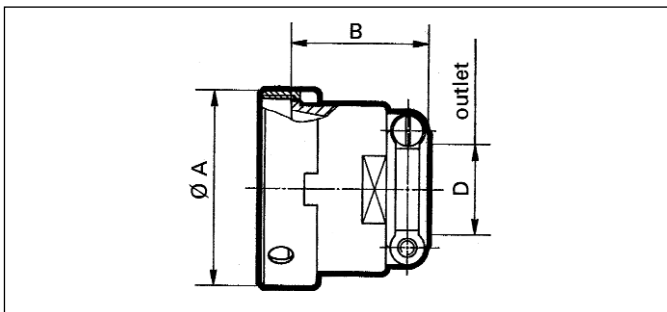

dim.	shells						
	1	2	3	4	5	6	
004	A	18.50 .73	22.50 .89	27.50 1.08	33.50 1.32	45 1.77	61 2.40
	B	15.50 .61	16.50 .65	23.50 .93	23.50 .93	27.50 1.08	45 1.77
	D	7 .28	10 .39	13.50 .53	15.50 .61	22.50 .89	36 1.42
003	B	22 .87	22 .87	23.50 .93	26.50 1.04	36.50 1.44	-
	D	8.50 .33	12 .47	15 .59	18 .71	27 1.06	-

Angled metal backshell with cable clamp type 005 and 006 depending on outlet Ø

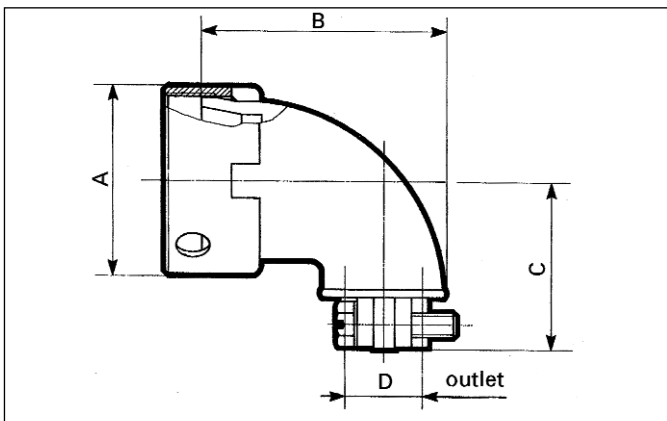

dim.	shells						
	1	2	3	4	5	6	
A	18.50 .73	22.50 .89	27.50 1.08	33.50 1.32	45 1.77	-	
standard outlet	006	B	27.50 .73	30 1.18	34.50 1.36	37.50 1.48	51 2.01
		C	16 .63	20.50 .81	22.50 .89	28 1.10	40 1.57
		D	6.50 .26	9.50 .37	13 .51	15 .59	22.50 .89
large outlet	005	B	-	43.50 1.71	45 1.77	51.50 2.03	-
		C	-	48 1.89	40.50 1.59	41.50 1.63	-
		D	-	17 .67	16 .63	20 .79	-

840 Series



Convertible straight angled backshell type 008 with cable clamp and sealing gland

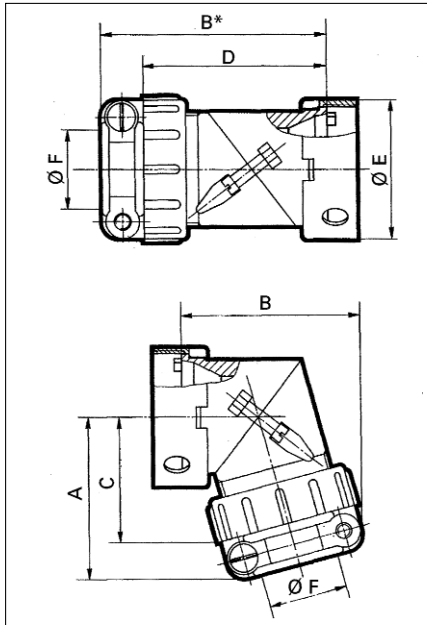

dim.	shells				
	1	2	3	4	5
A	22.50 .89	27.50 1.08	31.50 1.24	33 1.30	50.50 1.99
B	26 1.02	31.50 1.24	36.50 1.44	43.50 1.71	57 2.24
B*	33.50 1.32	40.50 1.59	46 1.81	55 2.17	74 2.91
C	18 .71	21.50 .85	25 .98	29.50 1.16	43.50 1.71
D	28.50 1.12	34.50 1.36	39 1.54	45 1.77	65.50 2.58
E	18.50 .73	22.50 .89	27.50 1.08	33.50 1.32	45 1.77
F	7 .28	10	15 .59	19 .75	22.50 .89

Metal backshell with sealing gland and cable clamp type 0010

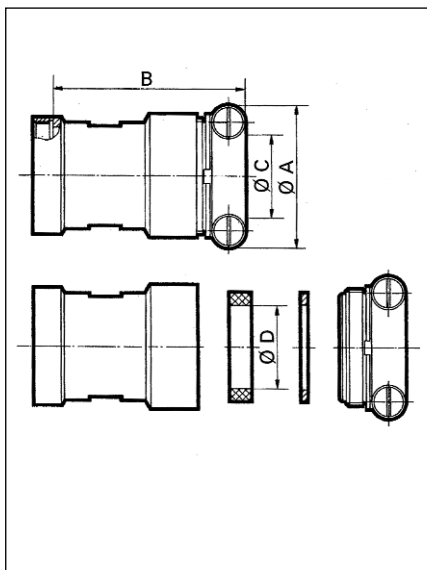

Ø of sealing gland gasket for backshell type 0010

dim.	shells		
	2	3	4
A	27.50 1.08	37 1.46	42 1.65
B	44.50 1.75	52.50 2.07	47.50 1.87
C	14.60 .57	19.60 .77	24.60 .97

shells	Ø D	specification
2	10.00 .39	003
	12.50 .49	004
	14.50 .57	005
3	14.00 .55	006
	16.00 .63	007
	18.00 .71	008
	19.50 .77	009
4	16.00 .63	010
	18.50 .73	011
	20.50 .81	012
	22.50 .89	013
	24.50 .96	014

Metal backshell with sealing gland type 0011

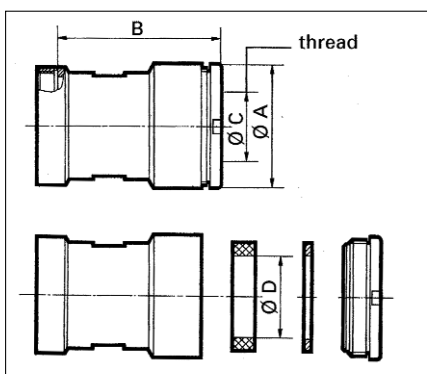

dim.	shells		
	2	3	4
A	26 1.02	31 1.22	36 1.42
B	39 1.54	44 1.73	49 1.93
C	15.25 .60 thread 1.41 .06	18.65 .73 thread 1.41 .06	20.45 .81 thread 1.41 .06
D	14.50 .57	19.50 .77	24.50 .96

840 Series

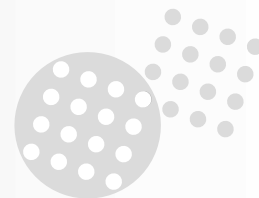

Crimp contacts

Contact Ø	Contact type	Part numbers	Admissible wire section				Max Ø over insulator	Part numbers Reducing sleeves	Admissible wire section			
			AWG		mm ²				AWG		mm ²	
			min	Max	min	Max		min	Max.	min	Max.	
Ø 1 all shells	male	8500-697	24	18	0.21	0.93	2.40	8500-781	30	26	0.06	0.15
	female	8500-1758										
Ø 1,5 small barrel shells 1, 2, 3, 4	male	8400-307A	22	18	0.38	0.93	3.30	63-584	30	24	0.06	0.21
	female	8400-619B										
Ø 1,5 large barrel shells 1, 2, 3, 4	male	8400-144A	16	14	1.34	1.91	3.30	-	-	-	-	-
	female	8400-618B										
Ø 2,5 shells 1, 2, 3, 4	male	8400-270A	12	10	3.18	5.30	5.10	8400-1665	14	-	1.91	-
	female	8400-147A										
Ø 3,5 all shells	male	8400-352A	-	8	8.98	-	6.40	8400-1029	10	-	5.30	-
	female	8400-148A										
Ø 5	male	8400-833	12	-	13.40	-	8.00	8400-2315	8	-	8.98	-
	female	8400-834										
Ø 10	male	8400-1799	-	-	16.00	-	8.50	-	-	-	-	-
	female	8400-1801										

Crimp contacts for shell sizes 5 and 6

Ø 1,5 small barrel	male	8400-309A	22	18	0.38	0.93	3.30	63 584	30	24	0.06	0.21
	female	8400-621B										
Ø 1,5 large barrel	male	8400-242A	16	14	1.34	1.91	3.30	-	-	-	-	-
	female	8400-620B										
Ø 2,5	male	8400-1407	12	10	3.18	5.30	5.10	8400-1665	14	-	1.91	-
	female	8400-1405										

840 Series



Accessories and tooling

Caps for receptacle

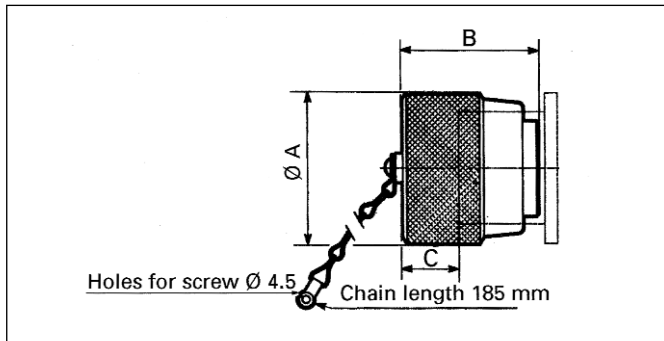

shells	caps for receptacle	caps for plug
1	8400-11	8400-21
2	8400-12	8400-22
3	8400-13	8400-23
4	8400-14	8400-24
5	8400-15	8400-25
6	8400-16	8400-26

Cap for plug

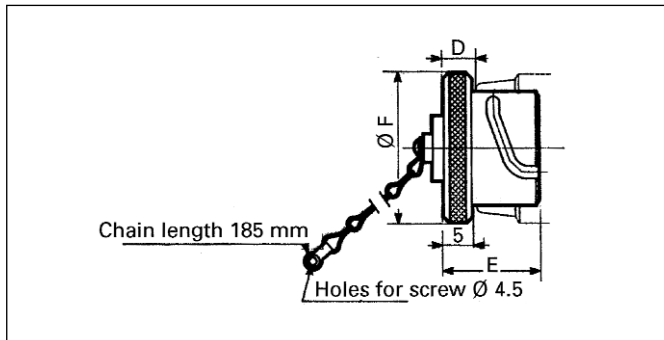

dim.	shells					
	1	2	3	4	5	6
A	22.50 .89	26.50 1.04	33 1.30	39 1.54	51 2.01	65 2.56
B	24.40 .96	24.30 .96	24.80 .98	24.80 .98	27.20 1.07	28.70 1.13
C	10.20 .40	10.20 .40	10.30 .41	10.30 .41	13.80 .54	14.30 .56
D	5.80 .23	5.80 .23	5.90 .23	5.90 .23	5.90 .23	5.90 .23
E	17 .67	17 .67	18 .71	18 .71	18 .71	18 .71
F	22.50 .89	26.50 1.04	33 1.30	39 1.54	49.80 1.96	64.50 2.54

Gasket for receptacle type 1

shells	1	2	3	4	5	6
Part numbers	8400-943	8400-944	8400-945	8400-2004	8400-2005	8400-1564

Crimping

Contacts Ø	Plier	Locator	
		shells 5 and 6	shells 1, 2, 3 and 4
Ø 1	MS 3191-1 SOURIAU 8465	MS 3191-20A	MS 3191-20A
Ø 1,5 small barrel	MS 3191-1 SOURIAU 8465	8400-1608	8400-1607
Ø 1,5 large barrel	MS 3191-1 SOURIAU 8465	8400-1609	MS3191-16A
Ø 2,5	MS 3191-1 SOURIAU 8465	8400-1721	8400-1610
Ø 3,5	8459	8459-130	8459-130
Ø 5	8459	8459-129	8459-129
Ø 10	8459	8459-168	8459-168

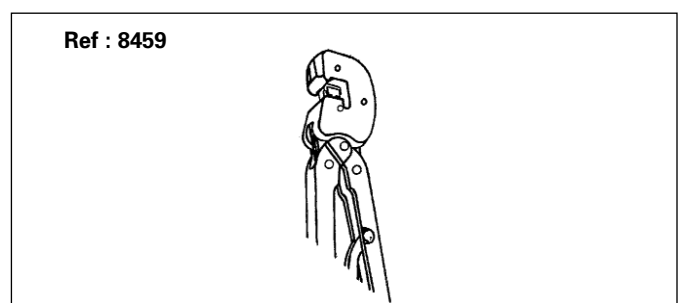
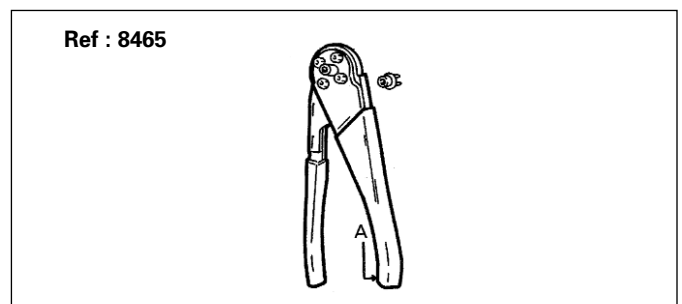

840 Series



Insertion tools

Contacts Ø	Shells 5 and 6	Shells 1, 2, 3 and 4
Ø 1	8400-2071	8500-93 B
Ø 1,5 small barrel	8400-482 A	
Ø 1,5 large barrel	8400-482 A	
Ø 2,5	8400-482 A	
Ø 3,5	8400-482 A	
Ø 5	8400-2129	
Ø 10	To insert contact : push in with wire	

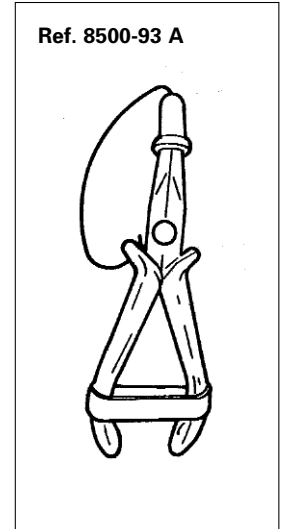
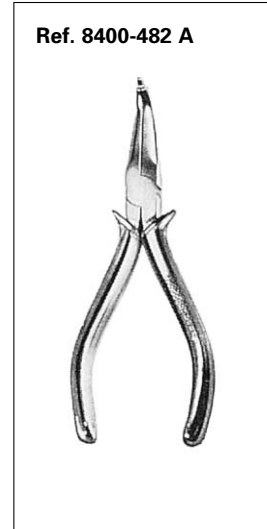
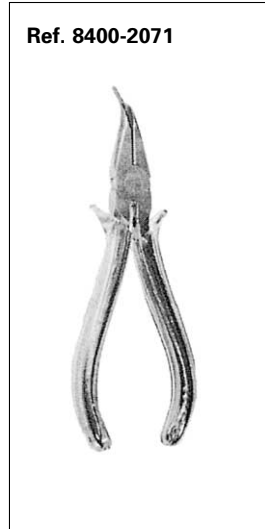

Extraction tools

Contacts Ø	Male contacts	Female contacts
Ø 1	8500-31	8500-31
Ø 1,5 small barrel	8400-448	8400-446
Ø 1,5 large barrel	8400-448	8400-446
Ø 2,5	8400-448	8400-322
Ø 3,5	8400-448	8400-322
Ø 5	8400-448	8400-980 A
Ø 10	manual extraction	

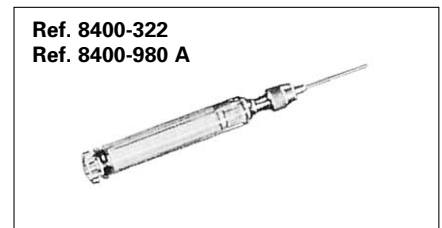
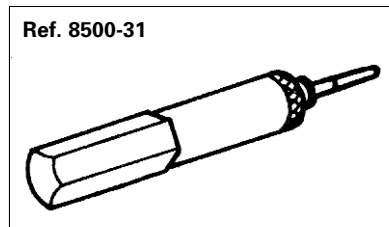

Note : for Ø 1 contact extraction from shell sizes 5 and 6 use tool part number 8310-31

Tightening support

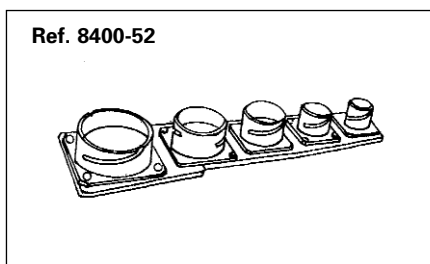

Backshell spanner

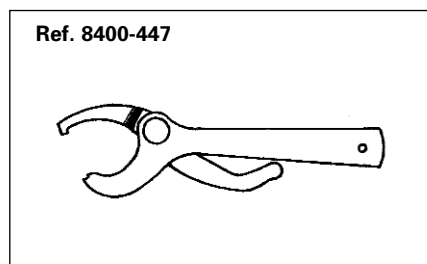

Strap clamp

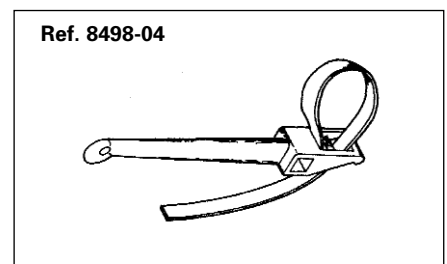

845 Series

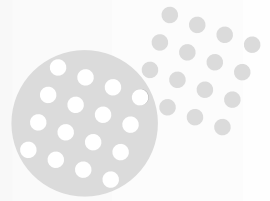

Applications

For all purposes in severe mechanical environment.
Power applications up to 200 A.

Standards

NFL 54120
GAM/T1 list



Description

- Shells in steel
- Plating : yellow cadmium bichromate or olive green cadmium
- Wide choice of contacts and contact layouts
- Environmental or sealed versions
- Bayonet coupling

Characteristics

Mechanical

- Endurance : 500 matings
- Shock : NFC 20616 level 50A
- Vibration : NFC 20616 level 55/10
- Contact retention (min) :

Ø 1 : 50N	Ø 3.5 : 100N
Ø 1.5 : 70N	Ø 5 : 150N
Ø 2.5 : 80N	Ø 10 : 200N

 (Ø in mm)

Electrical

- Maximum contact current rating :

Ø 1 : 7.5A	Ø 3.5 : 40A
Ø 1.5 : 11A	Ø 5 : 60A
Ø 2.5 : 25A	Ø 10 : 200A
- Test voltage : 2800 Vrms/50Hz
(except 1mm Ø contact : 1500 Vrms)
- Insulation resistance :
between contacts and earth at normal ambient temperature : $\geq 5000 \text{ M}\Omega$
- Contact resistance :

Ø 1 : 3 mΩ	Ø 3.5 : 0.35 mΩ
Ø 1.5 : 1.5 mΩ	Ø 5 : 0.25 mΩ
Ø 2.5 : 0.6 mΩ	Ø 10 : 0.08 mΩ

Environmental

- Temperature range : -40°C to +85°C
(+125°C peak)
- Humidity : to NFC 20603 for 56 days
- Salt spray : to NFC 20603 for 96 hours
- Fluid sealing :
 - immersed :
4 meters for 10 hours (standard version)
6 meters for 24 hours (sealed version)
 - water jet :
impact pressure 1 kg/cm² for 15 minutes

Without grommet seal

Ordering information

basic series		845	-21	-8	3	12
contact layouts	see table next page					
shell style	1- square flange receptacle 8- plug 5- in-line receptacle					
contact type	3- pin, solder 7- socket, solder 1- pin, crimp 5- socket, crimp					
cable fittings	00- connector without fitting* 15- backnut (corresponding to contact arrangement) 17- straight fitting with cable clamp (supplied with a grommet seal) 12- straight fitting for metal solder sleeve or heat shrink sleeving 14- elbow fitting for metal solder sleeve or heat shrink sleeving 36- elbow fitting with cable (supplied with a grommet seal corresponding to contact arrangement)					
special types	38- conduit tube fitting, plain 41- conduit tube fitting, braid					

* A connector may be ordered in this condition but cannot be utilised without specifying separately

example : connector 845-21-83-00
fitting 845-20-00-12

Note : Insulators and contacts are packed separately from connectors. Correct location of the insulator is made during assembly.
Style 1 receptacles are supplied complete with panel seals. The grommet seals provided with style 17 and 36 cable clamp fittings are not intended to be bonded to connector insulators.

845 Series

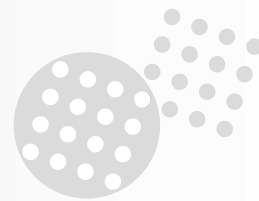

Contact layouts and polarizations Viewed from front face of male insulator

shell 1	3 Ø 1,5 11	2 Ø 1,5 12	1 Ø 3,5 13	7 Ø 1 19					
	shell 2	7 Ø 1,5 21	1 Ø 1,5 2 Ø 2,5 22	3 Ø 2,5 23	4 Ø 2,5 24	3 Ø 1,5 26	12 Ø 1 29		
		shell 3	12 Ø 1,5 31	3 Ø 3,5 32	4 Ø 3,5 33	2 Ø 3,5 4 Ø 1,5 34	1 Ø 10 35	19 Ø 1 39	
			shell 4	19 Ø 1,5 41	8 Ø 1,5 4 Ø 1,5 42	4 Ø 1,5 8 Ø 1,5 43	6 Ø 2,5 6 Ø 1,5 44	4 Ø 5 45	2 Ø 2,5 12 Ø 1,5 46
shell 5				37 Ø 1,5 51	19 Ø 2,5 52	26 Ø 1,5 53	61 Ø 1 54		

845 Series

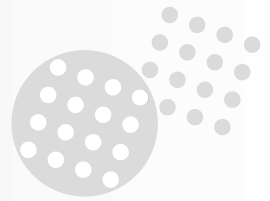

Shell styles Receptacle type 1

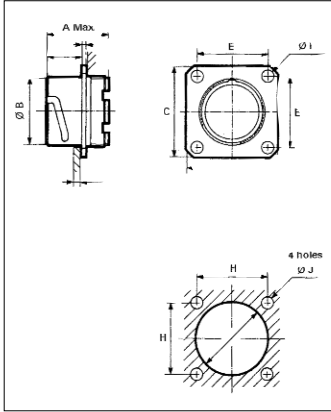

dim	shell size				
	1	2	3	4	5
A	28.20 1.110	28.20 1.110	28.60 1.126	28.60 1.126	38.00 1.496
B	16.00 .630	20.00 .787	26.00 1.024	31.00 1.220	43.00 1.693
C	15.50 .610	15.50 .610	16.50 .650	16.50 .650	16.50 .650
D	24.00 .945	27.00 1.063	31.00 1.220	42.00 1.654	54.00 2.126
E	18.00 .709	21.00 .827	25.00 .984	33.00 1.299	43.00 1.693
F	3.20 .126	3.20 .126	3.20 .126	5.50 .217	5.50 .217
G	19.00 .748	23.00 .906	28.00 1.102	34.00 1.339	46.00 1.811
H	18.00 .709	21.00 .827	25.00 .984	33.00 1.299	43.00 1.693
J	3.20 .126	3.20 .126	3.20 .126	5.50 .217	5.50 .217

Plug type 8

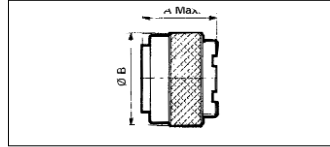

dim	shell size				
	1	2	3	4	5
A	32.20 1.268	32.20 1.268	32.20 1.268	32.20 1.268	41.60 1.638
B	22.50 .886	26.50 1.043	33.00 1.299	39.00 1.535	51.00 2.008

In-line receptacle type 5

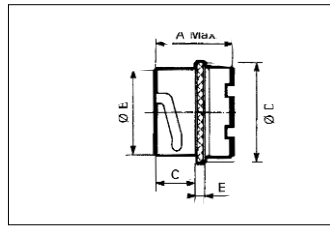

dim	shell size				
	1	2	3	4	5
A	28.00 1.102	28.00 1.102	28.40 1.118	28.40 1.118	37.80 1.488
B	16.00 .630	20.00 .787	26.00 1.024	31.00 1.220	43.00 1.693
C	14.00 .551	14.00 .551	14.80 .583	14.80 .583	14.80 .583
D	21.00 .827	25.00 .984	31.00 1.220	36.00 1.417	48.00 1.890
E	3.50 .138	3.50 .138	3.50 .138	3.50 .138	6.00 .236

Backfitting

backnut type 15

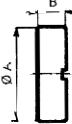

straight fitting with cable clamp type 17

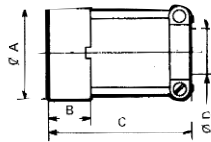

straight fitting for metal solder sleeve or heat shrink sleeving type 12

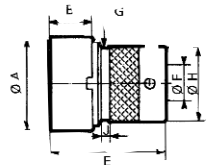

elbow fitting for metal solder sleeve or heat shrink sleeving type 14

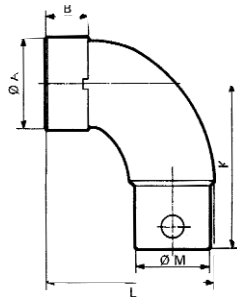

elbow fitting with cable clamp type 36

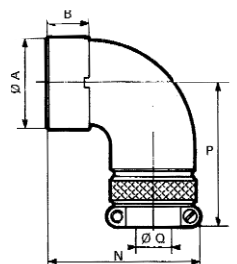

type	dim	shells size				
		1	2	3	4	5
15	A	18.50 .728	22.50 .886	27.50 1.083	33.50 1.319	44.80 1.764
	B	12.00 .472	10.10 .398	12.00 .472	10.10 .398	16.00 .630
17	A	18.50 .728	22.50 .886	27.50 1.083	33.50 1.319	45.00 1.772
	B	15.50 .610	15.50 .610	15.50 .610	15.50 .610	19.50 .768
	C	34.45 1.356	39.45 1.553	46.45 1.829	51.45 2.026	52.80 2.079
	D	11.00 .433	13.00 .512	17.00 .669	20.50 .807	30.00 1.181
12	A	18.50 .728	22.50 .886	27.50 1.083	33.50 1.319	45.00 1.772
	B	15.50 .610	15.50 .610	15.50 .610	15.50 .610	19.50 .768
	E	36.00 1.417	36.00 1.417	38.00 1.496	36.50 1.437	47.60 1.874
	F	12.00 .472	15.50 .610	21.50 .846	25.20 .992	37.00 1.457
	G	12.20 .480	16.00 .630	21.20 .835	27.00 1.063	38.00 1.496
	H	13.70 .539	17.50 .689	23.50 .925	27.00 1.063	40.00 1.575
	J	2.50 .098	2.50 .098	2.50 .098	2.50 .098	2.50 .098
14	A	18.50 .728	22.50 .886	27.50 1.083	33.50 1.319	45.00 1.772
	B	15.50 .610	15.50 .610	15.50 .610	15.50 .610	19.50 .768
	K	45.60 1.795	45.60 1.795	60.10 2.366	60.10 2.366	75.10 2.957
	L	43.15 1.699	40.15 1.581	61.65 2.427	59.65 2.348	70.55 2.778
	M	13.70 .539	17.50 .689	23.50 .925	27.00 1.063	40.00 1.575
36	A	18.50 .728	22.50 .886	27.50 1.083	33.50 1.319	45.00 1.772
	B	15.50 .610	15.50 .610	15.50 .610	15.50 .610	19.50 .768
	N	43.55 1.715	46.85 1.844	49.75 1.959	54.95 2.163	63.70 2.508
	P	37.50 1.476	42.50 1.673	47.50 1.870	53.50 2.106	72.30 2.846
	Q	11.00 .433	13.00 .512	17.00 .669	20.50 .807	30.00 1.181

845 Series



Plug/backfitting assemblies

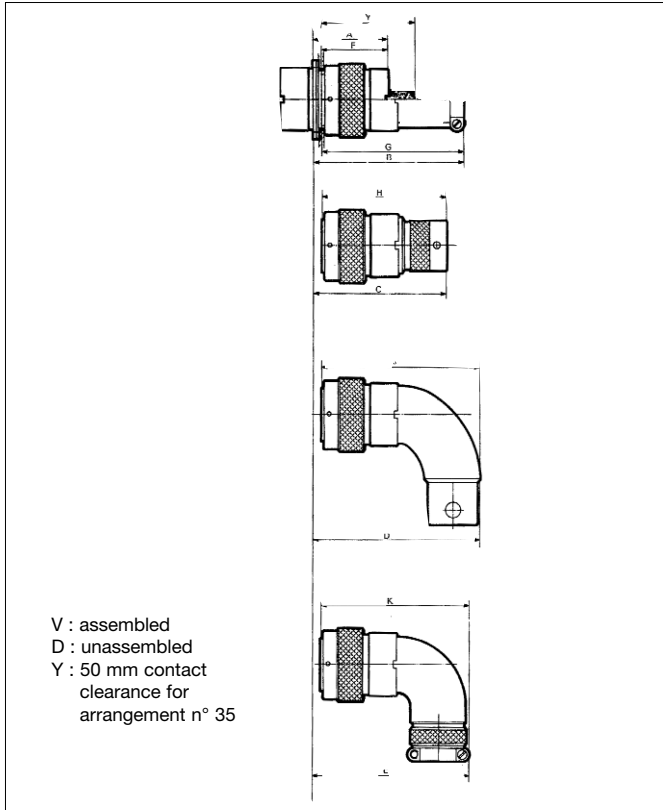

type	dim	shells size					
		1	2	3	4	5	
15	A	V	42.50 1.673	42.00 1.654	43.00 1.693	42.50 1.673	52.00 2.047
		D	55.50 2.185	55.50 2.185	56.50 2.224	56.50 2.224	63.00 2.480
	F	37.70 1.484	37.60 1.480	37.70 1.484	37.60 1.480	44.10 1.736	
17	B	V	64.00 2.520	69.00 2.717	76.50 3.012	81.50 3.209	93.00 3.661
		D	77.50 3.051	82.50 3.248	90.50 3.563	95.50 3.760	107.00 4.213
	G	59.70 2.350	64.70 2.547	71.70 2.823	76.70 3.020	87.90 3.461	
12	C	V	64.00 2.520	64.00 2.520	66.00 2.598	64.50 2.539	75.50 2.972
		D	84.50 3.327	81.50 3.209	105.00 4.134	102.00 4.016	122.50 4.823
	H	59.50 2.343	59.50 2.343	61.50 2.421	60.00 2.362	80.50 3.169	
14	D	V	71.00 2.795	68.00 2.677	91.00 3.583	88.00 3.465	108.50 4.272
		D	84.50 3.327	81.50 3.209	105.00 4.134	102.00 4.016	122.50 4.823
	J	66.50 2.618	63.70 2.508	86.20 3.394	83.20 3.276	103.50 4.075	
36	E	V	73.00 2.874	76.50 3.012	80.00 3.150	85.00 3.346	104.00 4.094
		D	86.50 3.406	90.00 3.543	93.50 3.681	99.00 3.898	118.00 4.646
	K	68.60 2.701	71.90 2.831	74.80 2.945	80.10 3.154	99.00 3.898	

Receptacle and in-line receptacle backfitting assemblies

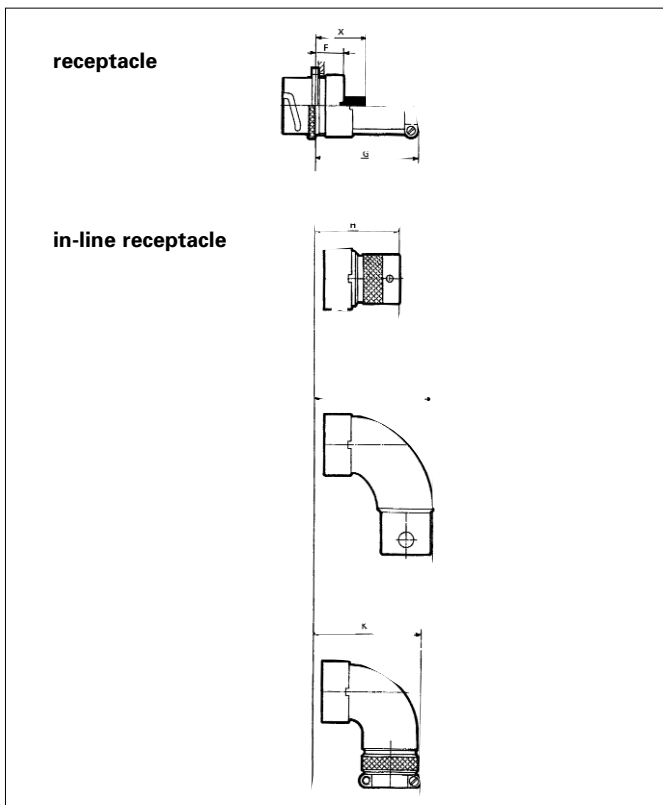

type	dim	shells size				
		1	2	3	4	5
15	F	16.00 .630	16.00 .630	17.00 .669	17.00 .669	25.00 .984
17	G	38.50 1.516	43.50 1.713	50.00 1.969	55.00 2.165	66.00 2.598
12	H	38.00 1.496	38.00 1.496	39.50 1.555	38.00 1.496	58.50 2.303
14	J	45.50 1.791	42.50 1.673	64.50 2.539	61.50 2.421	81.50 3.209
36	K	47.50 1.870	50.50 1.988	53.00 2.087	58.00 2.283	77.00 3.031

X : 28 mm contact clearance
for arrangement n° 35

845 Series



With grommet seal

Ordering information

basic series	845 -21 -8 3 22 -001					
contacts layouts	- see table below					
shell style	1 - square flange receptacle 8 - plug 5 - in-line receptacle					
contact type	3 - pin, solder 7 - socket, solder 1 - pin, crimp 5 - socket, crimp					
cable fittings	00 - connector without fitting* 25 - back nut 26 - fitting for heat shrink sleeving 22 - straight fitting with cable clamp		27 - short straight fitting with cable clamp 21 - straight fitting with cable clamp and gland 23 - elbow fitting with cable clamp and gland 24 - elbow fitting with cable clamp			
protection codes	001 - cadmium bichromate 003 - cadmium, olive green					

Contact layouts and polarizations

Viewed from front face of male insulator

shell 1	 3 Ø 1,5 11	 2 Ø 1,5 12	 1 Ø 3,5 13	 7 Ø 1 19			
shell 2	 7 Ø 1,5 21	 1 Ø 1,5 2 Ø 2,5 22	 3 Ø 2,5 23	 4 Ø 2,5 24	 12 Ø 1 29		
shell 3	 12 Ø 1,5 31	 3 Ø 3,5 32	 4 Ø 3,5 33	 2 Ø 3,5 4 Ø 1,5 34	 1 Ø 10 35	 19 Ø 1 39	
shell 4	 19 Ø 1,5 41	 8 Ø 1,5 4 Ø 2,5 42	 4 Ø 3,5 8 Ø 1,5 43	 6 Ø 2,5 6 Ø 1,5 44	 4 Ø 5 45	 2 Ø 2,5 12 Ø 1,5 46	 37 Ø 1 49
shell 5	 37 Ø 1,5 51	 19 Ø 2,5 52	 61 Ø 1 54				
shell 6	 4 Ø 10 61	 3 Ø 2,5 2 Ø 10 62	 55 Ø 1,5 64				

845 Series



Shell styles Receptacle type 1

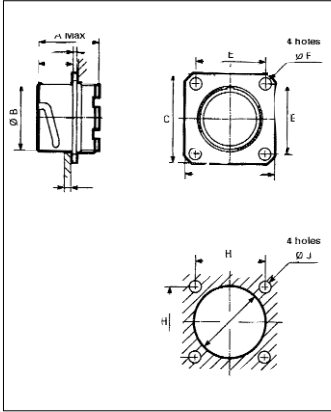

dim	shell size					
	1	2	3	4	5	6
A	28.20 1.110	28.20 1.110	28.60 1.126	28.60 1.126	38.00 1.496	38.00 1.496
B	16.00 .630	20.00 .787	26.00 1.024	31.00 1.220	43.00 1.693	57.00 2.244
C	15.50 .610	15.50 .610	16.50 .650	16.50 .650	16.50 .650	16.50 .650
D	24.00 .945	27.00 1.063	31.00 1.220	42.00 1.654	54.00 2.126	66.00 2.598
E	18.00 .709	21.00 .827	25.00 .984	33.00 1.299	43.00 1.693	53.00 2.087
F	3.20 .126	3.20 .126	3.20 .126	5.50 .217	5.50 .217	5.50 .217
G	19.00 .748	23.00 .906	28.00 1.102	34.00 1.339	46.00 1.811	60.00 2.362
H	18.00 .709	21.00 .827	25.00 .984	33.00 1.299	43.00 1.693	53.00 2.087
J	3.20 .126	3.20 .126	3.20 .126	5.50 .217	5.50 .217	5.50 .217

Plug type 8

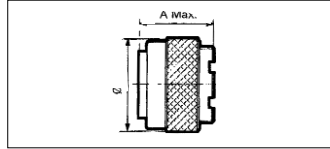

dim	shell size					
	1	2	3	4	5	6
A	32.20 1.268	32.20 1.268	32.20 1.268	32.20 1.268	41.60 1.638	41.60 1.638
B	22.50 .886	26.50 1.043	33.00 1.299	39.00 1.535	51.00 2.008	65.00 2.559

In-line receptacle type 5

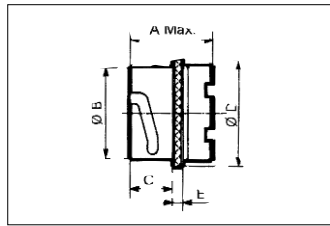

dim	shell size					
	1	2	3	4	5	6
A	28.00 1.102	28.00 1.102	28.40 1.118	28.40 1.118	37.80 1.488	37.80 1.488
B	16.00 .630	20.00 .787	26.00 1.024	31.00 1.220	43.00 1.693	57.00 2.244
C	14.00 .551	14.00 .551	14.80 .583	14.80 .583	14.80 .583	14.80 .583
D	21.00 .827	25.00 .984	31.00 1.220	36.00 1.417	48.00 1.890	62.00 2.441
E	3.50 .138	3.50 .138	3.50 .138	3.50 .138	6.00 .236	6.00 .236

Backfitting

backnut type 25



fitting for heat shrink sleeving type 26

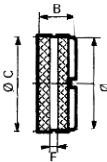

straight fitting with cable clamp type 22 short straight fitting with cable clamp type 27

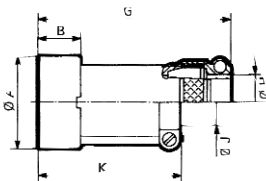

straight fitting with cable clamp type 21

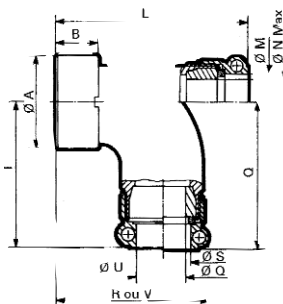

elbow fitting with cable clamp type 23

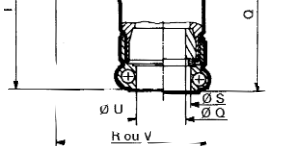

elbow fitting with cable clamp type 24

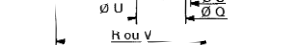

type 23

type 24

type	dim	shells size					
		1	2	3	4	5	6
25	A	18.50 .728	22.50 .886	27.50 1.083	33.50 1.319	44.80 1.764	59.50 2.343
	B	12.00 .472	10.10 .398	12.00 .472	10.10 .398	16.00 .630	19.80 .780
26	C	20.80 .819	23.50 .925	28.50 1.122	34.50 1.358	48.50 1.909	64.50 2.539
	D	15.00 .591	13.10 .516	15.00 .591	13.10 .516	19.00 .748	22.80 .898
	E	18.50 .728	22.60 .890	27.60 1.087	33.50 1.319	44.50 1.752	59.50 2.343
	F	3.50 .138	3.00 .118	3.00 .118	3.00 .118	3.50 .138	4.00 .157
22	A	18.50 .728	22.50 .886	27.50 1.083	33.50 1.319	45.00 1.772	61.50 2.421
	B	15.50 .610	15.50 .610	15.50 .610	15.50 .610	19.50 .768	20.50 .807
	G	44.90 1.768	53.90 2.122	60.90 2.398	69.90 2.752	84.30 3.319	119.00 4.685
27	H	11.00 .433	13.00 .512	17.00 .669	20.50 .807	30.00 1.181	40.00 1.575
	A	18.50 .728	22.50 .886	27.50 1.083	33.50 1.319	45.00 1.772	61.50 2.421
	B	15.50 .610	15.50 .610	15.50 .610	15.50 .610	19.50 .768	20.50 .807
21	J	11.00 .433	13.00 .512	17.00 .669	20.50 .807	30.00 1.181	40.00 1.575
	K	34.40 1.354	39.40 1.551	46.40 1.827	51.40 2.024	52.80 2.079	66.80 2.630
	A	18.50 .728	22.50 .886	27.50 1.083	33.50 1.319	45.00 1.772	61.50 2.421
23	B	15.50 .610	15.50 .610	15.50 .610	15.50 .610	19.50 .768	20.50 .807
	P	9.50 .374	12.50 .492	16.30 .642	19.20 .756	28.50 1.122	38.00 1.496
	Q	39.50 1.555	44.50 1.752	49.50 1.949	57.50 2.264	73.00 2.874	103.00 4.055
	R	43.50 1.713	46.80 1.843	49.70 1.957	54.90 2.161	63.70 2.508	93.50 3.681
	S	11.00 .433	13.00 .512	17.00 .669	20.50 .807	30.00 1.181	40.00 1.575
	A	18.50 .728	22.50 .886	27.50 1.083	33.50 1.319	45.00 1.772	61.50 2.421
	B	15.50 .610	15.50 .610	15.50 .610	15.50 .610	19.50 .768	20.50 .807
24	T	37.50 1.476	42.50 1.673	47.50 1.870	55.50 2.185	69.00 2.717	99.00 3.898
	U	11.00 .433	13.00 .512	17.00 .669	20.50 .807	30.00 1.181	40.00 1.575
	V	43.50 1.713	46.80 1.843	49.70 1.957	54.90 2.161	63.70 2.508	93.50 3.681
	A	18.50 .728	22.50 .886	27.50 1.083	33.50 1.319	45.00 1.772	61.50 2.421

845 Series



Plug/backfitting assemblies

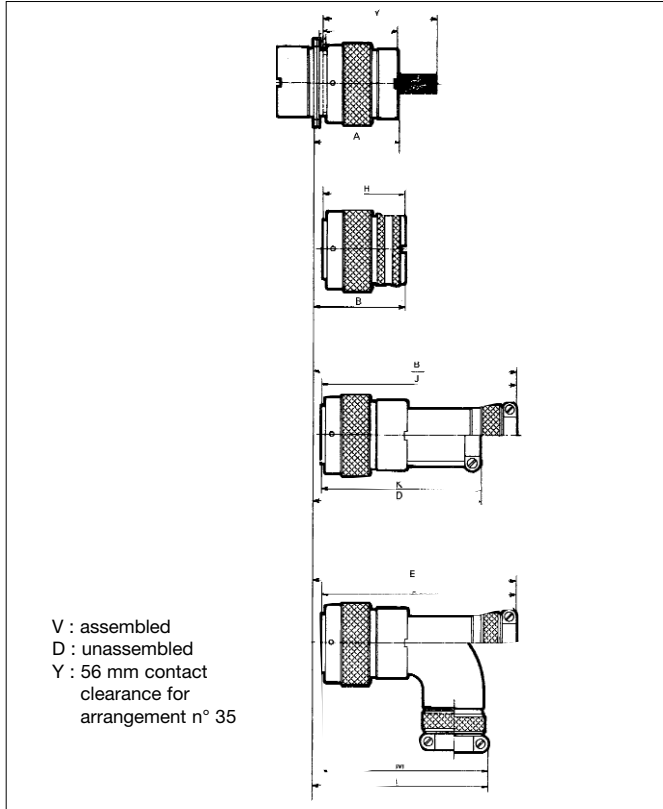

type	shells size dim	shells size						
		1	2	3	4	5	6	
25	A	V	42.50 1.673	42.50 1.673	43.00 1.693	44.00 1.732	52.50 2.067	55.00 2.165
		D	56.00 2.205	56.00 2.205	57.00 2.244	58.00 2.283	66.50 2.618	69.00 2.717
	G	38.50 1.516	38.00 1.496	38.50 1.516	39.00 1.535	47.50 1.870	50.50 1.988	
26	B	V	45.90 1.807	45.50 1.791	46.00 1.811	53.00 2.087	55.50 2.185	58.00 2.283
		D	59.00 2.323	59.00 2.323	60.00 2.362	61.00 2.402	69.50 2.736	72.00 2.835
	H	41.50 1.634	41.00 1.614	41.50 1.634	42.00 1.654	50.50 1.988	53.50 2.106	
22	C	V	74.50 2.933	83.50 3.287	91.00 3.583	100.00 3.937	124.50 4.902	155.00 6.102
		D	88.00 3.465	96.50 3.799	105.00 4.134	114.00 4.488	138.50 5.453	169.00 6.654
	J	70.50 2.776	78.50 3.091	86.50 3.406	95.50 3.760	119.50 4.705	150.00 5.906	
27	D	V	64.00 2.520	69.00 2.717	76.50 3.012	81.50 3.209	93.00 3.661	103.00 4.055
		D	77.50 3.051	82.50 3.248	90.50 3.563	95.50 3.760	107.00 4.213	117.00 4.606
	K	60.00 2.362	65.00 2.559	72.00 2.835	77.00 3.031	88.00 3.465	98.00 3.858	
21	E	V	77.00 3.031	86.00 3.386	93.50 3.681	102.50 4.035	128.50 5.059	160.00 6.299
		D	90.50 3.563	99.50 3.917	107.50 4.232	116.50 4.587	142.50 5.610	173.50 6.831
	L	72.50 2.854	81.50 3.209	88.50 3.484	97.50 3.839	124.00 4.882	155.00 6.102	
23-24	F	V	73.00 2.874	76.50 3.012	80.00 3.150	85.00 3.346	104.00 4.094	129.50 5.098
		D	86.50 3.406	90.00 3.543	93.50 3.681	99.00 3.898	118.00 4.646	144.50 5.689
	M	69.00 2.717	72.00 2.835	75.00 2.953	80.50 3.169	99.00 3.898	125.50 4.941	

Receptacle and in-line receptacle backfitting assemblies

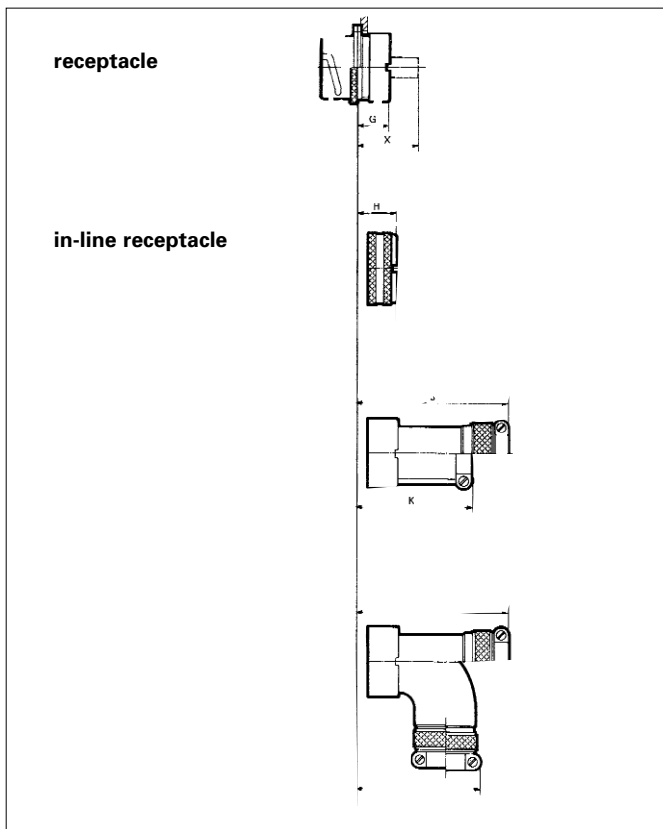

type	shells size dim	shells size					
		1	2	3	4	5	6
25	G	16.00 .630	16.00 .630	17.00 .669	17.00 .669	25.00 .984	28.00 1.102
26	H	19.50 .768	19.50 .768	19.00 .748	20.00 .787	28.50 1.122	31.50 1.240
22	J	48.50 1.909	57.50 2.264	64.00 2.520	73.00 2.874	97.50 3.839	128.00 5.039
27	K	38.50 1.516	43.50 1.713	49.50 1.949	54.50 2.146	66.00 2.598	76.00 2.992
21	L	51.00 2.008	60.00 2.362	66.50 2.618	75.50 2.972	102.00 4.016	133.00 5.236
23 - 24	M	47.50 1.870	50.50 1.988	53.00 2.087	58.00 2.283	77.00 3.031	102.50 4.035

X : 34 mm contact clearance for arrangement n° 35

845 Series

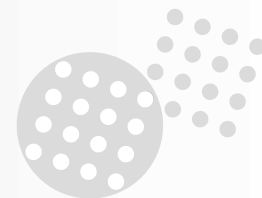

Accessories

Protective caps

Ordering information

basic series	845	-10	-00	31	-001
shell size	10 - 20 - 30 - 40 - 50 (excluding size 6)				
standard code					
caps	31 - for receptacles 32 - for plugs				
protection finish code	001 - cadmium bichromate 003 - cadmium olive green				

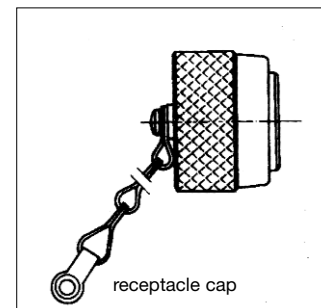
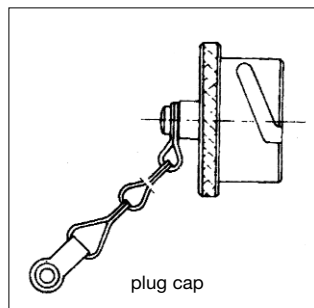

Sealing gaskets for square flange receptacle

shell size part number	8400-943	8400-944	8400-945	8400-946	8400-1180	8400-1564
---------------------------	----------	----------	----------	----------	-----------	-----------

Crimp contacts

diameter (mm)	female	male	wire size min/Max (mm ²)	insulation Ø min/Max (mm ²)	reducing sleeves	wire size with reducing sleeve min/Max (mm ²)
1	8500-1758	8201-326	0.21/0.93	1.55/2.40	8500-781	0.06/0.21
1.5	8400-618 A	8400-144 A	1.34/1.91	1.90/3.30		
1.5 (shells 5 and 6)	8400-620 A	8400-242 A	1.34/1.91	1.90/3.30		
2.5	8400-147 A	8400-270 A	3.18/5.30	3.50/5.10	8400-1665	1.91
2.5 (shells 5 and 6)	8400-1405	8400-1407	3.18/5.30	3.50/5.10	8400-1665	1.91
3.5	8400-148 A	8400-352 A	8.98	5.50/6.40	8400-1029	3.18/5.30
5	8400-834	8400-833	13.40	7.10/8.00	8400-2315	8.98
10 (arrangement 35)	8400-1183	8400-1181	67.20	14.40/15.50	8400-1779	41.80
10 (arrangement 61)	8400-1801	8400-1799	16.00	8.50		
10 (arrangement 62)	8400-1183	8400-1181	67.20	14.40/15.50	8400-1779	41.80

Solders contacts

diameter (mm)	female	male	Max wire size (mm ²)	insulation Ø min/Max (mm ²)
1.5	8400-622 A	8400-474	1.91	1.90/3.30
1.5 (shell 5 and 6)	8400-623 A	8400-475	1.91	1.90/3.30
2.5	8300-236	8300-235	5.30	3.50/5.10
2.5 (shell 5)	8473-119	8473-121	5.30	3.50/5.10
2.5 (shell 6)	8473-119	8473-121	5.30	3.50/5.10
3.5	8300-239	8300-238	8.98	5.50/6.40
5	8400-979	8400-961	13.40	7.10/8.00
10 (arrangement 35)	8400-1014	8400-986	67.20	14.40/15.50
10 (arrangement 61)	8400-1962	8400-1960	16.00	8.50
10 (arrangement 62)	8400-1014	8400-986	67.20	14.40/15.50

845 Series

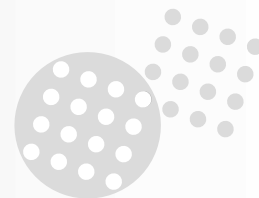

Tooling

Crimping tools (for both versions)

diameter of contact	plier	locator	
		shell size 5	others
1	MS 3191-1 SOURIAU 8465	MS 3191-20 A	MS 3191-20 A
1.5 small barrel	MS 3191-1 SOURIAU 8465	8400-1608	8400-1607
1.5 large barrel	MS 3191-1 SOURIAU 8465	8400-1609	MS 3191-16 A
2.5	MS 3191-1 SOURIAU 8465	8400-1721	8400-1610

diameter of contact	tool	locator	
		shell size 5	others
3,5	8459	8459-130 n°2	8459-130 n°2
5	8459	8459-129 n°1	8459-129 n°1
10	8463	8463-04	8463-04

Contact insertion tools

diameter of contact	GROMMET SEAL VERSION					
	shell size					
	5	1	2	3	4	6
1	8400-2071					
1.5	8400-1475					
2.5	8400-1475					
3.5	8400-1475					
5	insert manually	8400-2129				
10	insert manually					

diameter of contact	environmental version					
	shell size					
	5	1	2	3	4	6
1	8400-2071	8500-93 A				
1,5	8400-482 A					
2,5	8400-482 A					
3,5	8400-482 A					
5	insert manually	8400-2129				
10	insert manually					

Contact extraction tools (for both versions)

diameter of contact		shell size					
		5	1	2	3	4	6
1	male	8310-31	8500-31				
	female						
1,5	male	8400-448					
	female	8440-446					
2,5	male	8400-448					
	female	8400-322					

diameter of contact		shell size					
		5	1	2	3	4	6
3,5	male	8400-448					
	female	8400-322					
5	male	8400-448					
	female	8440-980*					
10	male	extract manually					
	female						

847 Series



Applications

Power supply (up to 63 A)

Standards

VG 96918

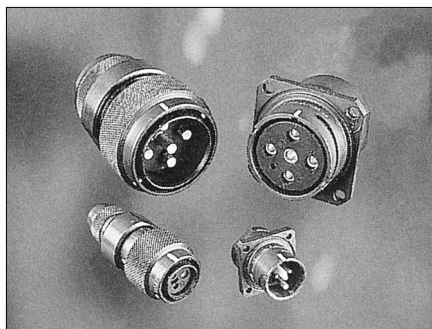

Description

- Bayonet coupling connector with crimp contacts
- Pilot and ground contacts available
- Contact layouts for :
 - mono 220 V
 - tri 220/380 + N + Pilot
- Shell continuity by grounding fingers.

Characteristics

Environmental

- Temperature range : - 55°C to + 85°C (125°C peak)
- Sealing (immersion) : 1 bar - 12 hours
- Salt spray resistance : 48 hours

Mechanical

- Shell : steel
- Backshell : steel
- Insulator : elastomer made in one piece
- Contacts : crimp, machined, from brass
- Plating : shells and backshells :
 - olive green cadmium
 - white cadmium
- contacts and shielding bracelet :
 - silver
- Endurance : 500 mating/unmating operations

Electrical

- Operating voltage :
 - shell 2 : 250 Vrms
 - shells 4-5 : 380 Vrms
- Current rating :
 - shell 2 : 16 A
 - shell 4 : 25 A
 - shell 5 : 63 A
- Withstanding voltage : 2000 Veff

Ordering information (with contacts and backshells)

basic series	847	48	F	5	47	N	3	02
contact layout	25-48-58							
shell type	A : square flange receptacle, smooth holes, without thread for backfitting B : square flange receptacle, smooth holes, with thread for backfitting L : square flange receptacle, threaded holes, without thread for backfitting M : square flange receptacle, threaded holes, with thread for backfitting F : plug P : cable connecting receptacle D : jam nut receptacle with thread for backfitting R : jam nut receptacle without thread for backfitting							
contact type	1 : crimp male contact 5 : crimp female contact							
backshell type	00 : receptacles (A, L, R types), without thread for backfitting receptacles (B, M, D), plugs and cable connecting receptacles supplied without backshell 21 : straight cable clamp and sealing gland backshell 23 : elbow cable clamp and sealing gland backshell 47 : straight backshell for shield termination and heatshrink sleeving 48 : straight backshell for shield termination and heatshrink sleeving and tightening shield ring							
orientation	N, W, X, Y : in all cases (orientation during the wiring operation)							
insert type ^{① ② ③}	0 : without grommet, without pilot contact 1 : with grommet, without pilot contact 2 : without grommet, with pilot contact 3 : with grommet, with pilot contact		① contact layout 25 : inserts are without pilot contact ② contact layout 58 : inserts are only with grommet ③ contact layouts 25 and 48 : with or without pilot contact Filler plug is supplied					
specifications	02 : olive green cadmium 03 : olive green cadmium with specific contacts 09 : white cadmium							

847 Series



Contact layouts and polarizations

viewed from front face of male insulator

contact layout 25 - MONO 220 V + ⊕

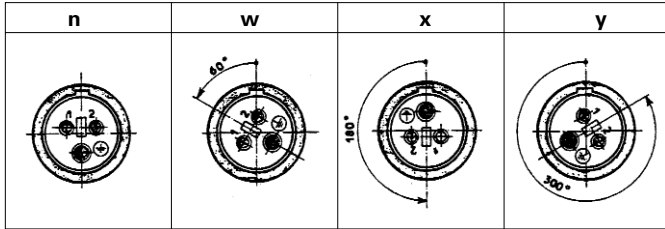

contact layout 48 TRI 220/380 V + N + Pilot + ⊕

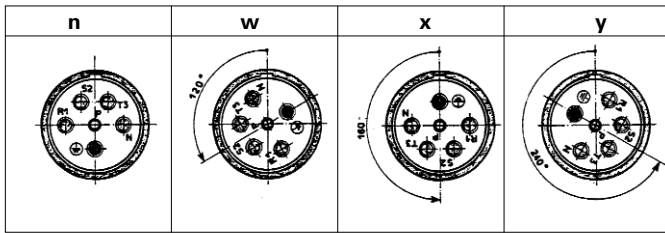

contact layout 58 TRI 220/380 V + N + Pilot ⊕

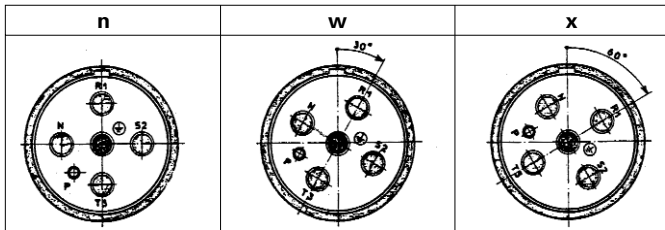

Contacts

(only for 02 and 09 spec.)

		contact layouts		
		25	48	58
male contact	phase	8400.2311	8400.2182	8400.2322
	ground	8400.2181	8400.2183	8400.2323 ^①
	pilot	-	8400.2312	
female contact	phase	8400.2313	8400.2214	8400.2321
	ground	8400.2213	8400.2215	8400.2324 ^①
	pilot	-	8400.2216	
	filler plug ^②	-	8522.389A	
	reducing ^③ sleeve	-	8400.3506 ^④	8400.2315 ^⑤ 8400.2327 ^⑤

^① Contact in two parts : contact body and crimping tip

^② Insure sealing for version without pilot contact

^③ to order separately

^④ for wire section 0.93 mm²

^⑤ for wire section 5.30 mm²

^⑥ for wire section 8.98 mm²

usable for phase
and ground contacts

Dimensions

Square flange receptacle, smooth or threaded holes without thread for backfitting

A and L types

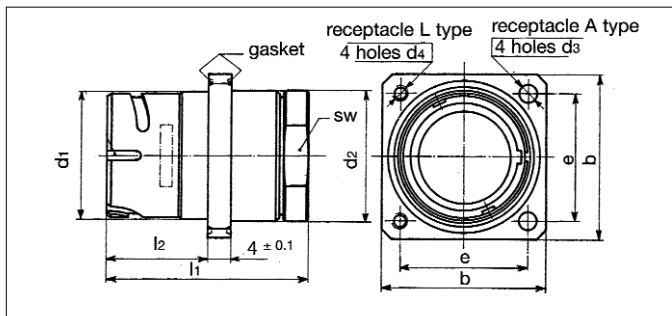

shell	d1 Max	d2 Max	d3	d4	l1 Max	l2 Max	e	b Max	sw
2	20.5 .807	22 .866	3.2 .126	M3	33.5 1.319	16.6 .654	21 .827	27 1.063	19 .748
4	31.5 1.240	32.8 1.291	5.5 .217	M5	35.6 1.402	17.5 .689	33 1.299	42 1.654	30 1.181
5	43.1 1.697	45 1.772	5.5 .217	M5	49 1.929	18.8 .740	43 1.693	54 2.126	42 1.654

Panel cut-out

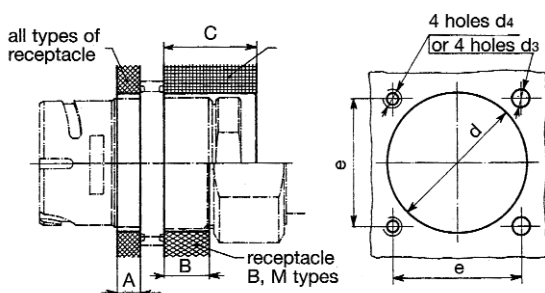

shell	A Max	B Max	C Max	d	e	d3	d4
2	3.75 .148	6.5 .256	illimited	23 .906	21 .827	3.2 .126	M3
4	4.0 .157	6.5 .256	illimited	34 1.339	33 1.299	5.5 .217	M5
5	5.75 .226	6.5 .256	illimited	46 1.811	43 1.693	5.5 .217	M5

847 Series



Square flange receptacle, smooth or threaded holes, with thread for backfitting B and M types

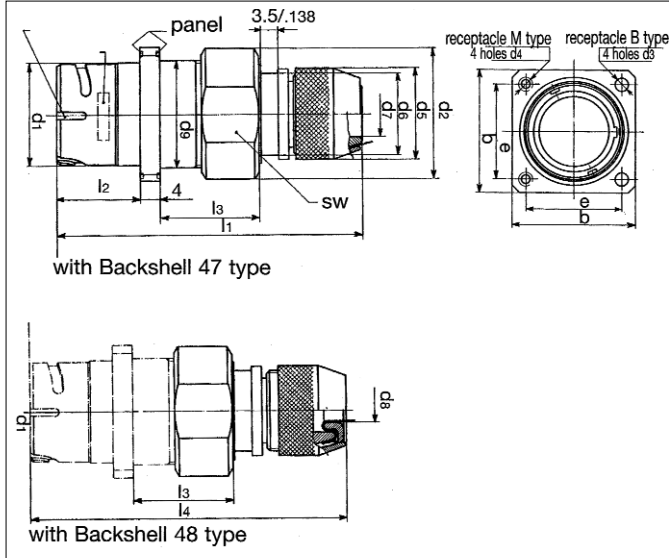

shell	d2 Max	d5 Max	d6	d7	d8	d9 Max	l1 Max	l3 Max	l4 Max	sw
2	26.1 1.028	18.1 .713	16.1 .634	9.2 .362	- -	21.5 .846	61.2 2.409	20.3 .799	- -	24 .945
4	38.6 1.520	28.1 1.106	26.2 1.031	18.3 .720	12.8 .504	33 1.299	64.5 2.539	21.7 .854	66.7 2.626	36 1.417
5	50.6 1.992	41.1 1.618	37.5 1.476	28.8 1.134	21.6 .850	44 1.732	68.5 2.697	22.6 .890	70.7 2.783	46 1.811

Dimensions d1, d3, d4, e, b, l2 are identical with A and L type receptacle

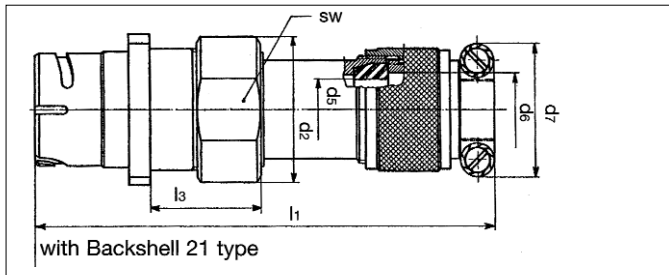

shell	d2 Max	d5 Max	d6 Max	d7 Max	l1 Max	l3 Max	sw
2	26.1 1.028	12.6 .496	13.1 .516	23.8 .937	82.3 3.240	20.3 .799	24 .945
4	38.6 1.520	19.1 .752	20.6 .811	33.8 1.331	98.1 3.862	21.7 .854	36 1.417
5	50.6 1.992	28.6 1.126	30.1 1.185	43.8 1.724	119.7 4.713	22.6 .890	46 1.811

Jam nut receptacle without thread for backfitting

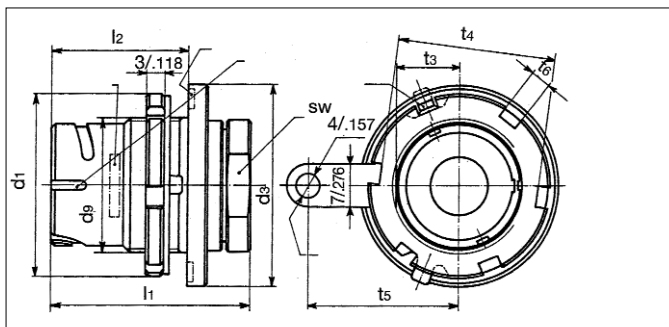

shell	d1	d9	d3 Max	l1 Max	l2 Max	t3 Max	t4 Max	t5	t6	sw
2	30 1.181	M22x1	33 1.299	33.4 1.315	22.5 .886	10.4 .409	26 1.024	25 .984	3.5 .138	19 .748
4	46 1.811	M36x1.5	48 1.890	35.5 1.398	23.2 .913	16 .630	41 1.614	34 1.339	5 .197	30 1.181
5	57 2.244	M48x1.5	59 2.323	49 1.929	23.5 .925	22.4 .882	52 2.047	39.5 1.555	5 .197	42 1.654

Panel cut-out

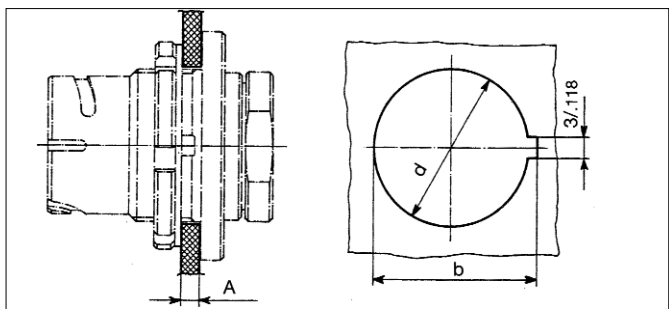

shell	A Max	d	b
2	3 .118	22.2 .874	24.2 .953
4	3 .118	36.2 1.425	38.2 1.504
5	3 .118	48.2 1.898	50.2 1.976

847 Series



Jam nut receptacle with thread for backfitting

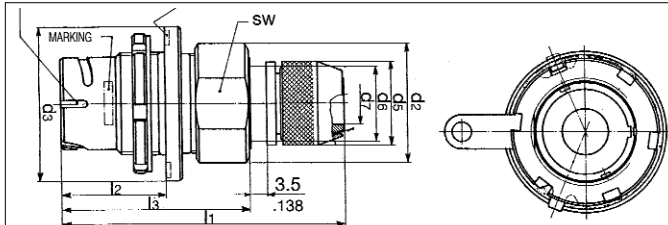

with Backshell 47 type

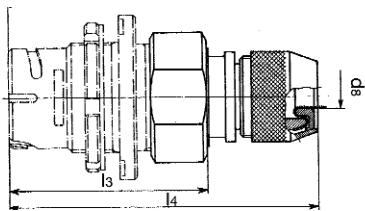

with Backshell 48 type

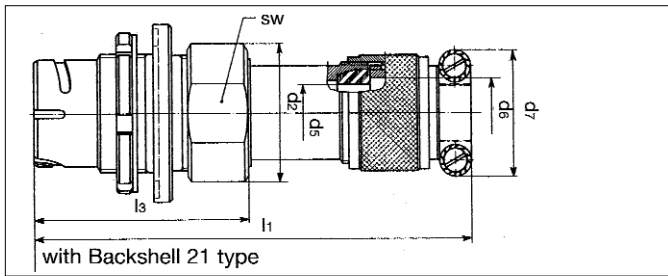

with Backshell 21 type

shell	d2 Max	d3 Max	d5 Max	d6	d7	d8	l1 Max	l2 Max	l3 Max	l4 Max	sw
2	26.1 1.028	33 1.299	18.1 .713	16.1 .634	9.2 .362	- -	61.1 2.406	22.5 .886	38.6 1.520	- -	24 .945
4	38.6 1.520	48 1.890	28.1 1.106	26.2 1.031	18.3 .720	12.8 .504	64.4 2.535	23.2 .913	41.2 1.622	66.6 2.622	36 1.417
5	50.6 1.992	59 2.323	41.1 1.618	37.5 1.476	28.8 1.134	21.6 .850	68.4 2.693	23.5 .925	44.9 1.768	70.7 2.783	46 1.811

shell	d2 Max	d5 Max	d6 Max	d7 Max	l1 Max	l3 Max	sw
2	26.1 1.028	12.6 .496	13.1 .516	23.8 .937	82.3 3.240	38.6 1.520	24 .945
4	38.6 1.520	19.1 .752	20.6 .811	33.8 1.331	98.1 3.862	41.2 1.622	36 1.417
5	50.6 1.992	28.6 1.126	30.1 1.185	43.8 1.724	119.7 4.713	44.9 1.768	46 1.811

Plug F type

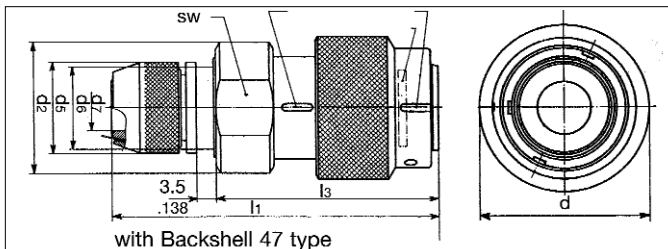

with Backshell 47 type

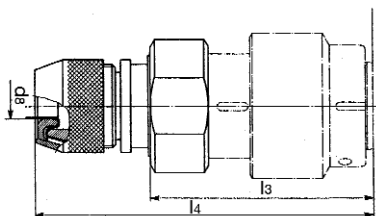

with Backshell 48 type

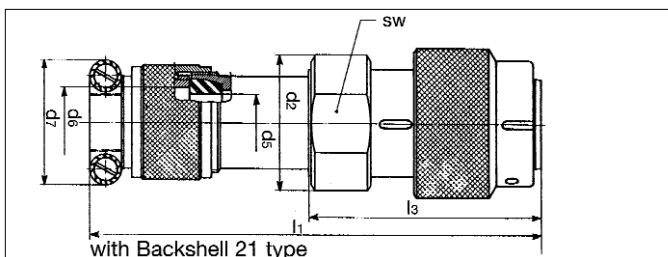

with Backshell 21 type

shell	d Max	d2 Max	d5 Max	d6	l3 Max	sw
2	28.6 1.126	26.1 1.028	18.1 .713	16.1 .634	44 1.732	24 .945
4	41.1 1.618	38.6 1.520	28.1 1.106	26.2 1.031	46.5 1.831	36 1.417
5	53.1 2.091	50.6 1.992	41.1 1.618	37.5 1.476	48.8 1.921	46 1.811

shell	d7	l1 Max	d8	l4 Max
2	9.2 .362	64.2 2.528	- -	- -
4	18.3 .720	67.7 2.665	12.8 .504	69.9 2.752
5	28.8 1.134	71.8 2.827	21.6 .850	74.1 2.917

shell	d2 Max	d5 Max	d6 Max	d7 Max	l1 Max	l3 Max	sw
2	26.1 1.028	12.6 .496	13.1 .516	23.8 .937	85.4 3.362	44 1.732	24 .945
4	38.6 1.520	19.1 .752	20.6 .811	33.8 1.331	101.4 3.992	46.5 1.831	36 1.417
5	50.6 1.992	28.6 1.126	30.1 1.185	43.8 1.724	123.0 4.843	46.8 1.843	46 1.811

847 Series



Cable connecting receptacle P type

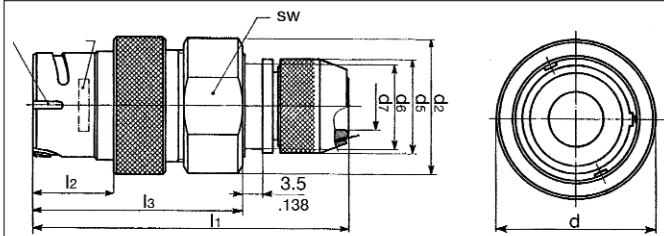

with Backshell 47 type

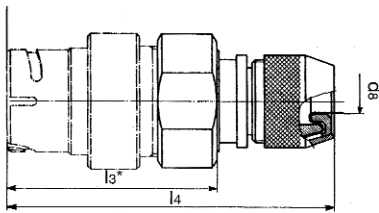

with Backshell 48 type

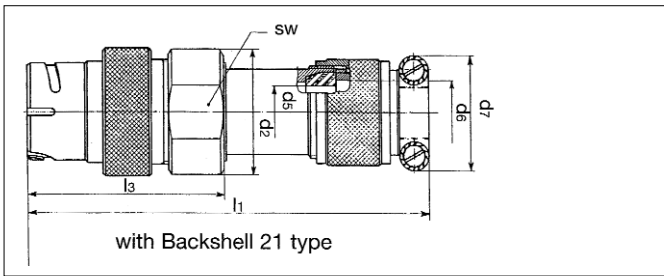

with Backshell 21 type

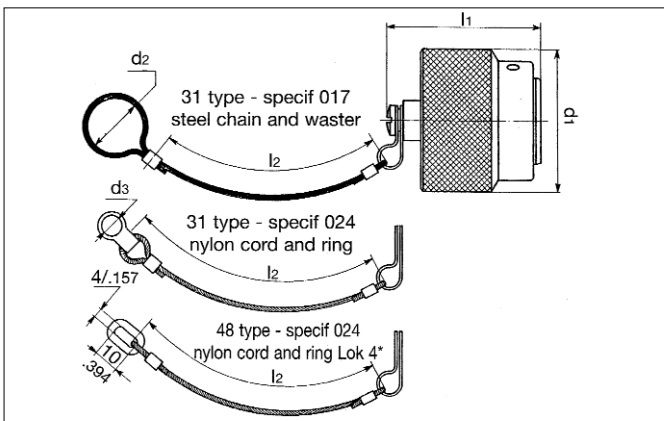

* Mounting with insulok (Hellermann) collar

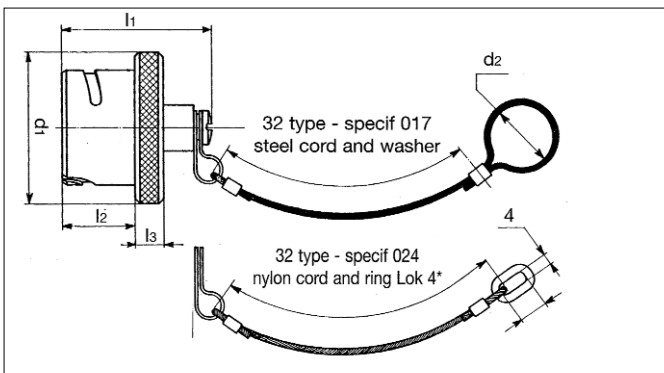

* Mounting with insulok (Hellermann) collar

shell	d	d2 Max	d5 Max	d6	l2	l3 Max	sw
2	26.5 1.043	26.1 1.028	18.1 .713	16.1 .634	15.5 .610	40.6 1.598	24 .945
4	39 1.535	38.6 1.520	28.1 1.106	26.2 1.031	16.4 .646	42.9 1.689	36 1.417
5	51 2.008	50.6 1.992	41.1 1.618	37.5 1.476	13.5 .531	45.1 1.776	46 1.811

shell	d7	l1 Max	d8	l4 Max
2	9.2 .362	60.9 2.398	-	-
4	18.3 .720	63.5 2.500	12.8 .504	65.7 2.587
5	28.8 1.134	68.2 2.685	21.6 .850	70.5 2.776

shell	d2 Max	d5 Max	d6 Max	d7 Max	l1 Max	l3 Max	sw
2	26.1 1.028	12.6 .496	13.1 .516	23.8 .937	82 3.228	40.6 1.598	24 .945
4	38.6 1.520	19.1 .752	20.6 .811	33.8 1.331	97.8 3.850	42.9 1.689	36 1.417
5	50.6 1.992	28.6 1.126	30.1 1.185	43.8 1.724	119.4 4.701	45.1 1.776	46 1.811

part numbers

8.45.20.0031.017
8.45.40.0031.017
8.45.50.0031.017

8.45.20.0031.024
8.45.40.0031.024
8.45.50.0031.024

8.45.20.0048.024
8.45.40.0048.024
8.45.50.0048.024

dim	2	4	5
d1 Max	26.6 1.047	39.1 1.539	51.1 2.012
d2	23 .906	34 1.339	46 1.811
d3	5 .197	5 .197	5 .197
l1 Max	31.5 1.240	31.5 1.240	34.5 1.358
l2	130 5.118	130 5.118	130 5.118

part numbers

8.45.20.0032.017
8.45.40.0032.017
8.45.50.0032.017

8.45.20.0032.024
8.45.40.0032.024
8.45.50.0032.024

dim	2	4	5
d1 Max	26.6 1.047	39.1 1.539	50 1.969
d2	23 .906	34 1.339	46 1.811
l1 Max	27 1.063	27.2 1.071	27.2 1.071
l2 Max	12.5 .492	13.2 .520	13.2 .520
l3 Max	5.1 .201	5.1 .201	5.1 .201
l4	130 5.118	130 5.118	130 5.118

847 Series

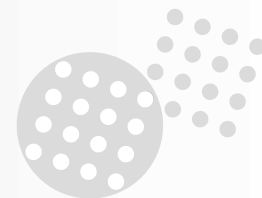

Cable stripping (for type 47 and 48 backshells)

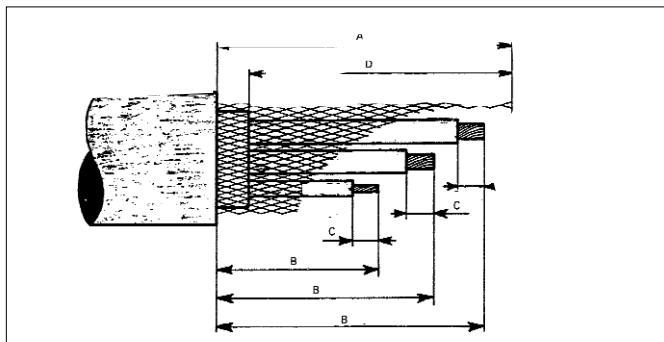

shell	A	D	type of cont.	B	C
2	50 1.969	40 1.575	ground	50 1.969	6.5 .256
			phase	45 1.772	
4	55 2.165	45 1.772	ground	55 2.165	6.5 .256
			phase	50 1.969	
			pilot	55 2.165	
5	70 2.756	50 1.969	ground	70 2.756	11 .433
			phase	65 2.559	
			pilot	70 2.756	6.5 .256

Crimping tools

shell	plier	turret	type of contact	turret position	section cable (mm ²)	selector position
2	M22520-1/01 (8365)	8400.2281	ground	red	1.34 à 1.50 1.91	6 7
			phase	blue	1.34 à 1.50 1.91	6 7
4	M22520-1/01 (8365)	8400.2282	ground	red	2.5 à 4.0	8
			phase	blue	2.5 à 4.0	8
			pilot	yellow	0.50 à 0.75	4
5	MS3191-1 (8465)	8400.2336	pilot	-	0.50 à 0.75	-
	M22520-1/01 (8365)	8400.2282		yellow	0.50 à 0.75	4
	8459	8459.129	ground phase	-	13.40	-

Extraction and insertion tools

shell	remark	type of contact	insertion tool male/female	extraction tool (male)	extraction tool (female)
2	-	phase	8400.1475	8400.448	8400.446
		ground			8400.322
4	without grommet	pilot	8500.29A	8500.31	8500.31
	with grommet		8400.2071		
4	-	phase	8400.1475	8400.448	8400.322
		ground			
5	-	pilot	8400.2071	8310.31	8310.31
		phase	8400.2428	8400.448	8400.980
			8380.02		
-	ground	8400.1549	8400.1549	8400.1549	

Cable

cable characteristics		shell 2	shell 4	shell 5
Ø over insulator Max	type 21 et 23 backshell	12.50 .492	19.00 .748	28.50 1.122
	type 47 backshell	9.10 .358	18.20 .717	28.70 1.130
	type 48 backshell	-	12.80 .504	21.60 .850
		-	-	-
Ø braid strands		0.20 .008	0.25 .010	0.40 .016
pilot wire	over insulator Max dia.	-	-	2.30 .091
	over insulator min dia.	-	-	1.80 .071
	section min (mm ²)	-	-	0.50 .0008
	section Max (mm ²)	-	-	0.75 .0012
ground and phase wires	over insulator Max dia.	3.30 .130	4.40 .173	8.00 .315
	over insulator min dia.	2.30 .091	3.10 .122	7.00 .276
	section min (mm ²)	1.34 .0021	2.50 .0039	13.40 .0208
	section Max (mm ²)	1.91 .0030	4.00 .0062	

Heat shrink sleeves (for type 47 and 48 backshells)

shell	straight-sleeve	bent-sleeve
2	202 K 132 - 4	222 K 132 - 4
4	202 K 163 - 4	222 K 163 - 4
5	202 K 174 - 4	222 K 174 - 4

X-ON Electronics

Largest Supplier of Electrical and Electronic Components

Click to view similar products for [Circular MIL Spec Connector](#) category:

Click to view products by [Sunbank](#) manufacturer:

Other Similar products are found below :

[89075GULPR](#) [0025-262-542](#) [58-584653-12P](#) [0134-202-1200](#) [0134-207-1206](#) [0134-207-1800](#) [0134-207-2207](#) [0134-213-0806](#) [0134-213-1007](#)
[0134-213-1009](#) [0134-213-1200](#) [0134-213-1208](#) [0134-213-1800](#) [0134-213-2209](#) [0025-258-000](#) [015-9516-002](#) [5M30-61](#) [60-042217-10P](#) [60-](#)
[042722-19P](#) [0114-201-1278](#) [024251-0015](#) [602GB06EG1832SN](#) [602GB06EG24-61SN](#) [0134-201-1207](#) [0134-201-1806](#) [0134-201-2006](#) [0134-](#)
[201-2007](#) [0134-201-2010](#) [0134-202-1400](#) [0134-207-0809](#) [0134-207-1208](#) [0134-207-2009](#) [0134-213-0800](#) [0134-213-1006](#) [0134-213-1008](#)
[6104-209-1702](#) [61-168211-04P](#) [6131-202-19149P](#) [6131-204-21149P](#) [6131-207-13149P](#) [6131-208-13149P](#) [6131-209-17149P](#) [6131-210-](#)
[11149P](#) [6131-211-19149P](#) [6131-216-19149P](#) [6131-220-25149P](#) [6131-259-11149P](#) [6131-259-21149P](#) [6131-259-23149P](#) [6131-263-19149P](#)