

SPECIFICATIONS

Customer	
Product Name	Multi-layer Chip Ceramic Inductor
Sunlord Part Number	SDCL1005-M01 Series
Customer Part Number	

New Released, Revised]

SPEC No.: SDCL02130000

[This SPEC is total 9 pages including specifications and appendix.]

[ROHS Compliant Parts]

Approved By	Checked By	Issued By

Shenzhen Sunlord Electronics Co., Ltd.

Address: Sunlord Industrial Park, Dafuyuan Industrial Zone, Baoan, Shenzhen, China 518110
 Tel: 0086-755-29832660 Fax: 0086-755-82269029 E-Mail: sunlord@sunlordinc.com

【For Customer approval Only】

Date: _____

Qualification Status: Full Restricted Rejected

Approved By	Verified By	Re-checked By	Checked By

Comments:

【Version change history】

Rev.	Effective Date	Changed Contents	Change Reasons	Approved By
01	/	New release	/	Hai Guo

1. Scope

This specification applies to SDCL1005-M01 series of multi-layer ceramic chip inductor.

2. Product Description and Identification (Part Number)

- 1) Description
SDCL series of multi-layer ceramic chip inductor.

- 2) Product Identification (Part Number)

SDCL 1005 C XXX _ _ D E M01

Type	
SDCL	Chip Ceramic Inductor

External Dimensions (L X W) (mm)	
1005 [0402]	1.0 X 0.5

Material Code	
C	

Nominal Inductance	
Example	Nominal Value
3N9	3.9nH
10N	10nH

Inductance Tolerance	
S	±0.3nH
J	±5%
k	±10%

Packing	
T	Tape Carrier Package

HSF Products	
Hazardous Substance Free Products	

Internal Code	
D	

Design Code	
M01	

3. Electrical Characteristics

Please refer to **Appendix A** (Page 9).

- 1) Operating and storage temperature range (individual chip without packing): -55 ~ +125
- 2) Storage temperature range (packaging conditions): -10 ~+40 and RH 70% (Max.)

4. Shape and Dimensions

- 1) Dimensions and recommended PCB pattern for reflow soldering: See **Fig.4-1**, **Fig.4-2** and **Table 4-1**.
- 2) Structure: See **Fig. 4-3** and **Fig. 4-4**.

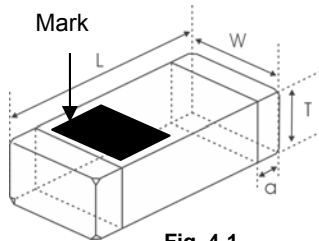

Fig. 4-1

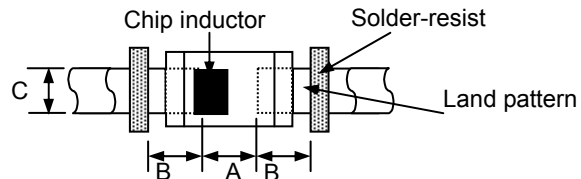

Fig. 4-2

[Table 4-1]

Unit: mm [inch]

Type	L	W	T	a	A	B	C
1005 [0402]	1.0±0.15 [0.039±0.006]	0.5±0.15 [0.020±0.006]	0.5±0.15 [0.020±0.006]	0.25±0.1 [0.010±0.004]	0.45~0.55	0.40~0.50	0.45~0.55

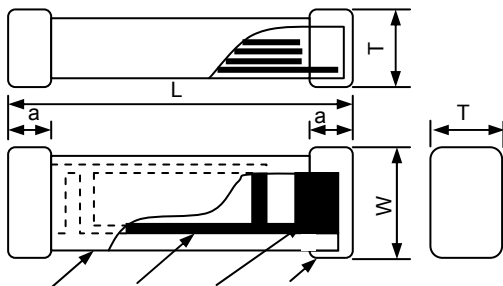

Fig. 4-3

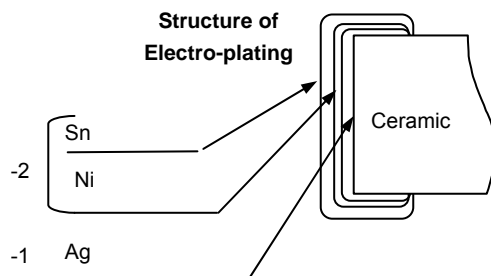

Fig. 4-4

Ceramic for SDCL Series
 Internal electrode (Ag)
 Pull out electrode (Ag)
 -1 Terminal electrode: Inside (Ag)
 -2 Outside (Electro-plating Ni-Sn)

- 3) Material Information: See **Table 4-2**

[Table 4-2]

Code	Part Name	Material Name
	Ceramic Body	Ceramic Powder
	Inner Coils	Silver Paste
	Pull-out Electrode (Ag)	Silver Paste
-1	Terminal Electrode: Inside Ag	Termination Silver Composition
-2	Electro-Plating: Ni/Sn plating	Plating Chemicals

5. Test and Measurement Procedures

5.1 Test Conditions

Unless otherwise specified, the standard atmospheric conditions for measurement/test as:

- Ambient Temperature: 20 ± 15
- Relative Humidity: $65 \pm 20\%$
- Air Pressure: 86kPa to 106kPa

If any doubt on the results, measurements/tests should be made within the following limits:

- Ambient Temperature: 20 ± 2
- Relative Humidity: $65 \pm 5\%$
- Air Pressure: 86kPa to 106kPa

5.2 Visual Examination

- Inspection Equipment: 20× magnifier

5.3 Electrical Test

5.3.1 DC Resistance (DCR)

- Refer to **Appendix A**.
- Test equipment (Analyzer): High Accuracy Milliohmmeter-HP4338B or equivalent.

5.3.2 Inductance (L)

- Refer to **Appendix A**.
- Test equipment: High Accuracy RF Impedance /Material Analyzer-E4991A+HP16192A or equivalent.
- Test signal: -20dBm or 50mV
- Test frequency refers to **Appendix A**.
- Test compensation: product true value=test value + compensation value, the compensation value is -0.2nH.

5.3.3 Q Factor (Q)

- Refer to **Appendix A**.
- Test equipment: High Accuracy RF Impedance /Material Analyzer-E4991A+HP16192A or equivalent.
- Test signal: -20dBm or 50mV
- Test frequency refers to **Appendix A**.

5.3.4 Self-Resonant Frequency (SRF)

- Refer to **Appendix A**.
- Test equipment: Agilent 8719ES or equivalent.
- Test signal: -20dBm or 50 mV

5.3.5 Rated Current

- Refer to **Appendix A**.
- Test equipment (see **Fig. 5.3.5-1**): Electric Power, Electric current meter, Thermometer.
- Measurement method (see **Fig. 5.3.5-1**):
 - Set test current to be 0mA.
 - Measure initial temperature of chip surface.
 - Gradually increase voltage and measure chip temperature for corresponding current.
- Definition of Rated Current(I_r): I_r is direct electric current as chip surface temperature rose just 20 against chip initial surface temperature(T_a) (see **Fig. 5.3.5-2**).

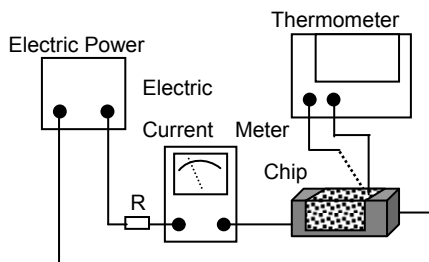

Fig. 5.3.5-1

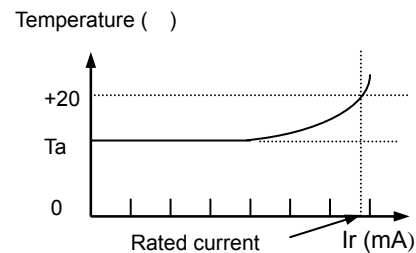
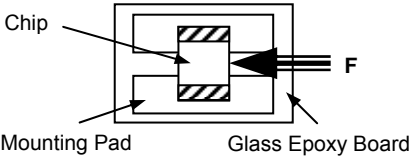
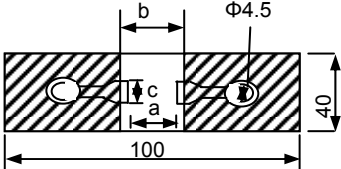
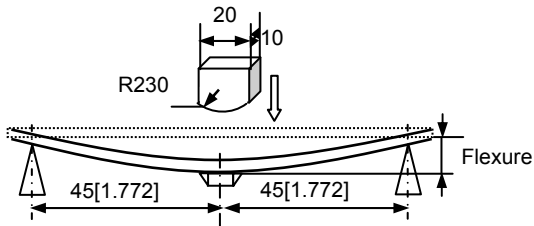
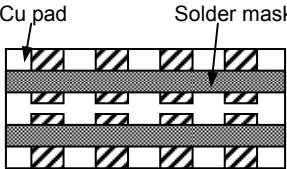
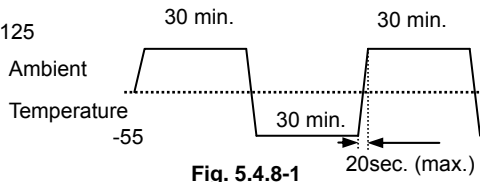

Fig. 5.3.5-2

5.4 Reliability Test

Items	Requirements	Test Methods and Remarks								
5.4.1 Terminal Strength	No removal or split of the termination or other defects shall occur.  <p style="text-align: center;">Fig.5.4.1-1</p>	Solder the inductor to the testing jig (glass epoxy board shown in Fig. 5.4.1-1) using eutectic solder. Then apply a force in the direction of the arrow. 5N force for 1005 series. Keep time: 10±1s Speed: 1.0mm/s.								
5.4.2 Resistance to Flexure	No visible mechanical damage. Unit: mm [inch] <table border="1" data-bbox="325 551 756 640"> <thead> <tr> <th>Type</th> <th>a</th> <th>b</th> <th>c</th> </tr> </thead> <tbody> <tr> <td>1005[0402]</td> <td>0.4</td> <td>1.5</td> <td>0.5</td> </tr> </tbody> </table>  <p style="text-align: center;">Fig. 5.4.2-1</p>	Type	a	b	c	1005[0402]	0.4	1.5	0.5	Solder the inductor to the test jig (glass epoxy board shown in Fig. 5.4.2-1) Using a eutectic solder. Then apply a force in the direction shown Fig. 5.4.2-2 . Flexure: 2mm. Pressurizing Speed: 0.5mm/sec. Keep time: 30 sec.  <p style="text-align: center;">Fig. 5.4.2-2</p>
Type	a	b	c							
1005[0402]	0.4	1.5	0.5							
5.4.3 Vibration	No visible mechanical damage. Inductance change: Within ±10%. Q factor change: Within ±20%.  <p style="text-align: center;">Fig. 5.4.3-1</p>	Solder the inductor to the testing jig (glass epoxy board shown in Fig. 5.4.3-1) using eutectic solder. The inductor shall be subjected to a simple harmonic motion having total amplitude of 1.5mm, the frequency being varied uniformly between the approximate limits of 10 and 55 Hz. The frequency range from 10 to 55 Hz and return to 10 Hz shall be traversed in approximately 1 minute. This motion shall be applied for a period of 2 hours in each 3 mutually perpendicular directions (total of 6 hours).								
5.4.4 Dropping	No visible mechanical damage. Inductance change: Within ±10%. Q factor change: Within ±20%.	Drop chip inductor 10 times on a concrete floor from a height of 100 cm.								
5.4.5 Temperature	Inductance change should be within ±10% of initial value measuring at 20 .	Temperature range: -55 to +125 , Reference temperature: 20								
5.4.6 Solderability	No visible mechanical damage. Wetting shall exceed 95% coverage	Solder temperature: 240±2 Duration: 3 sec. Solder: Sn/3.0Ag/0.5Cu. Flux: 25% Resin and 75% ethanol in weight.								
5.4.7 Resistance to Soldering Heat	No visible mechanical damage. Wetting shall exceed 95% coverage Inductance change: Within ±10%. Q factor change: Within ±20%.	Solder temperature: 260±3 Duration: 5 sec. Solder: Sn/3.0Ag/0.5Cu. Flux: 25% Resin and 75% ethanol in weight. The chip shall be stabilized at normal condition for 1~2 hours before measuring.								

<p>5.4.8 Thermal Shock</p>	<p>No mechanical damage. Inductance change: Within $\pm 10\%$. Q factor change: Within $\pm 20\%$.</p>  <p>Fig. 5.4.8-1</p>	<p>Temperature, Time: (See Fig. 5.4.8-1) -55 for 30±3 min→125 for 30±3min, Transforming interval: Max. 20 sec. Tested cycle: 100 cycles. The chip shall be stabilized at normal condition for 1~2 hours before measuring.</p>
<p>5.4.9 Resistance to Low Temperature</p>	<p>No mechanical damage. Inductance change: Within $\pm 10\%$. Q factor change: Within $\pm 20\%$.</p>	<p>Temperature: -55 ± 2 , Duration: 1000^{+24} hours. The chip shall be stabilized at normal condition for 1~2 hours before measuring.</p>
<p>5.4.10 Resistance to High Temperature</p>	<p>No mechanical damage. Inductance change: Within $\pm 10\%$. Q factor change: Within $\pm 20\%$.</p>	<p>Temperature: 125 ± 2 , Duration: 1000^{+24} hours. The chip shall be stabilized at normal condition for 1~2 hours before measuring.</p>
<p>5.4.11 Damp Heat (Steady States)</p>	<p>No visible mechanical damage. Inductance change: Within $\pm 10\%$. Q factor change: Within $\pm 20\%$.</p>	<p>Temperature: 60 ± 2 Humidity: 90% to 95% RH. Duration: 1000^{+24} hours. The chip shall be stabilized at normal condition for 1~2 hours before measuring.</p>
<p>5.4.12 Loading Under Damp Heat</p>	<p>No visible mechanical damage. Inductance change: Within $\pm 10\%$. Q factor change: Within $\pm 20\%$.</p>	<p>Temperature: 60 ± 2 Humidity: 90% to 95% RH. Duration: 1000^{+24} hours. Applied current: Rated current. The chip shall be stabilized at normal condition for 1~2 hours before measuring.</p>
<p>5.4.13 Loading at High Temperature (Life Test)</p>	<p>No visible mechanical damage. Inductance change: Within $\pm 10\%$. Q factor change: Within $\pm 20\%$.</p>	<p>Temperature: 125 ± 2 , Duration: 1000^{+24} hours. Applied current: Rated current. The chip shall be stabilized at normal condition for 1~2 hours before measuring.</p>

6. Packaging and Storage

6.1 Packaging

Tape Carrier Packaging:

Packaging code: T

- a. Tape carrier packaging are specified in attached figure Fig.6.1-1~3
- b. Tape carrier packaging quantity please see the following table:

Type	1005[0402]
T(mm)	0.5±0.15
Tape	Paper Tape
Quantity	10K

(1) Taping Drawings (Unit: mm)

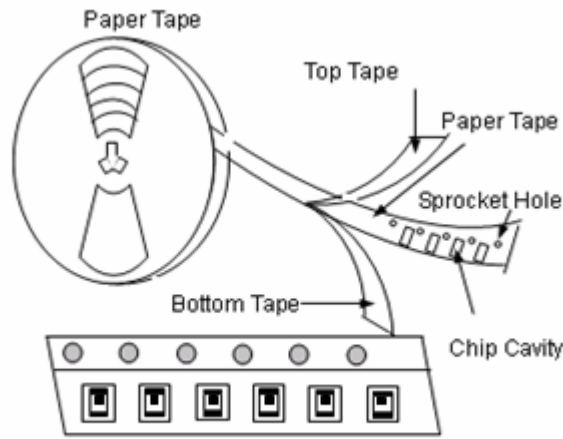

Remark: The sprocket holes are to the right as the tape is pulled toward the user.

Fig. 6.1-1

(2) Taping Dimensions (Unit: mm)

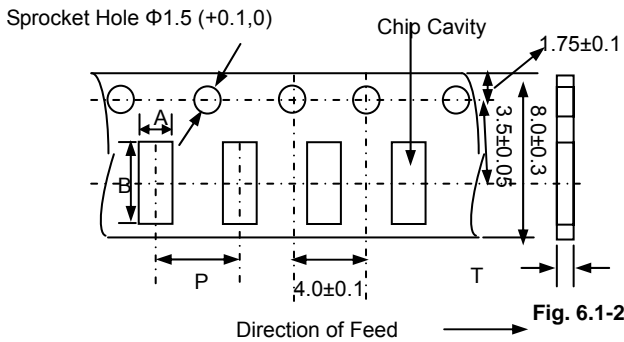

Paper Tape

Type	A	B	P	T max
1005[0402]	0.65 ± 0.1	1.15 ± 0.1	2.0 ± 0.05	0.8

Fig. 6.1-2

(3) Reel Dimensions (Unit: mm)

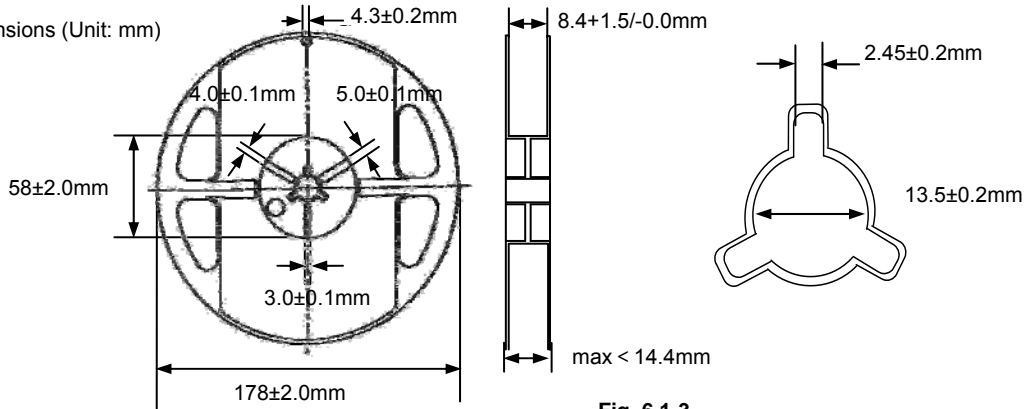

Fig. 6.1-3

6.2 Storage

- a. The solderability of the external electrode may be deteriorated if packages are stored where they are exposed to high humidity. Package must be stored at 40 or less and 70% RH or less.
- b. The solderability of the external electrode may be deteriorated if packages are stored where they are exposed to dust of harmful gas (e.g. HCl, sulfurous gas of H₂S).
- c. Packaging material may be deformed if package are stored where they are exposed to heat of direct sunlight.
- d. Solderability specified in **Clause 5.4.6** shall be guaranteed for 12 months from the date of delivery on condition that they are stored at the environment specified in **Clause 3**. For those parts, which passed more than 12 months shall be checked solder-ability before use.

7. Recommended Soldering Technologies

7.1 Re-flowing Profile:

- 1~2 /sec. Ramp.
- Pre-heating: 150~190 /90±30 sec.
- Time above 240 : 20~40sec.
- Peak temperature: 260 Max. /10sec.
- Solder paste: Sn/3.0Ag/0.5Cu.
- Max.2 times for re-flowing.

[Note: The reflow profile in the above table is only for qualification and is not meant to specify board assembly profiles. Actual board assembly profiles must be based on the customer's specific board design, solder paste and process, and should not exceed the parameters as the Reflow profile shows.]

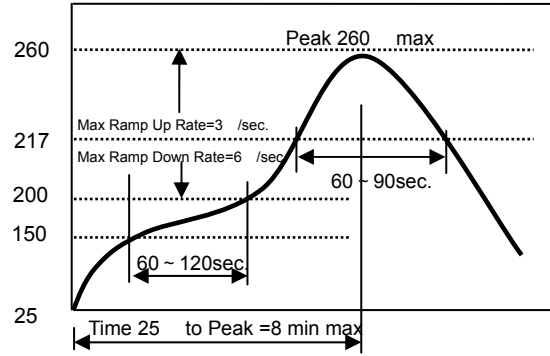

7.2 Iron Soldering Profile.

- Iron soldering power: Max.30W.
- Pre-heating: 150 / 60 sec.
- Soldering Tip temperature: 350 Max.
- Soldering time: 3sec Max.
- Solder paste: Sn/3.0Ag/0.5Cu.
- Max.1 times for iron soldering.

[Note: Take care not to apply the tip of the soldering iron to the terminal electrodes.]

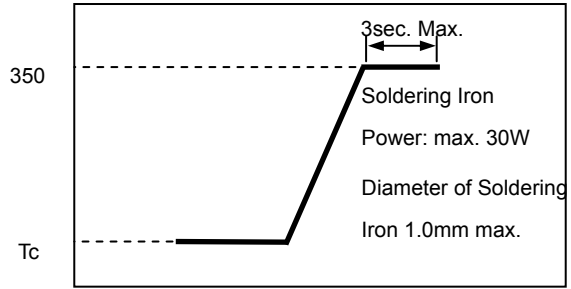

8. Supplier Information

- a) Supplier:
Shenzhen Sunlord Electronics Co., Ltd.
- b) Manufacturer:
Shenzhen Sunlord Electronics Co., Ltd.
- c) Manufacturing Address:
Sunlord Industrial Park, Dafuyuan Industrial Zone, Guanlan, Shenzhen, China 518110

Appendix A: Electrical Characteristics

SDCL1005-M01 Series

Part Number	L (nH)	Q Min.	L, Q Test. Freq (MHz)	Q (Typ.) Freq. (MHz)			S.R.F (MHz) Min	DCR (Ω) Max.	I _r (mA) Max.	Thickness (mm) [inch]
				100	800	1000				
SDCL1005C1N0STDFM01	1.0±0.3	8	100	11	34	36	10000	0.10	400	0.5±0.15 [.020±.006]
SDCL1005C1N1STDFM01	1.1±0.3	8	100	11	34	36	10000	0.10	400	
SDCL1005C1N2STDFM01	1.2±0.3	8	100	11	34	36	10000	0.10	400	
SDCL1005C1N3STDFM01	1.3±0.3	8	100	11	34	36	10000	0.10	400	
SDCL1005C1N5STDFM01	1.5±0.3	8	100	11	34	36	6000	0.10	300	
SDCL1005C1N6STDFM01	1.6±0.3	8	100	11	32	35	6000	0.10	300	
SDCL1005C1N8STDFM01	1.8±0.3	8	100	11	30	34	6000	0.10	300	
SDCL1005C2N0STDFM01	2.0±0.3	8	100	10	29	33	6000	0.20	300	
SDCL1005C2N2STDFM01	2.2±0.3	8	100	10	29	33	6000	0.20	300	
SDCL1005C2N4STDFM01	2.4±0.3	8	100	10	29	32	6000	0.20	300	
SDCL1005C2N7STDFM01	2.7±0.3	8	100	10	29	32	6000	0.20	300	
SDCL1005C3N0STDFM01	3.0±0.3	8	100	10	29	32	6000	0.20	300	
SDCL1005C3N3STDFM01	3.3±0.3	8	100	10	29	32	6000	0.20	300	
SDCL1005C3N6STDFM01	3.6±0.3	8	100	10	28	31	4000	0.20	300	
SDCL1005C3N9STDFM01	3.9±0.3	8	100	10	28	31	4000	0.20	300	
SDCL1005C4N3STDFM01	4.3±0.3	8	100	10	28	31	4000	0.20	300	
SDCL1005C4N7STDFM01	4.7±0.3	8	100	10	28	31	4000	0.20	300	
SDCL1005C5N1STDFM01	5.1±0.3	8	100	10	28	30	4000	0.30	300	
SDCL1005C5N6STDFM01	5.6±0.3	8	100	10	28	30	4000	0.30	300	
SDCL1005C6N2STDFM01	6.2±0.3	8	100	10	27	30	3900	0.30	300	
SDCL1005C6N8 TDFM01	6.8	8	100	10	27	30	3900	0.30	300	
SDCL1005C7N5 TDFM01	7.5	8	100	10	27	30	3700	0.40	300	
SDCL1005C8N2 TDFM01	8.2	8	100	10	27	30	3600	0.40	300	
SDCL1005C9N1 TDFM01	9.1	8	100	10	27	30	3400	0.40	300	
SDCL1005C10N TDFM01	10	8	100	10	27	30	3200	0.40	300	

: Please specify the inductance tolerance: J=±5%, K=±10%.

X-ON Electronics

Largest Supplier of Electrical and Electronic Components

Click to view similar products for [Fixed Inductors](#) category:

Click to view products by [Sunlord](#) manufacturer:

Other Similar products are found below :

[MLZ1608M6R8WTD25](#) [MLZ1608N6R8LT000](#) [MLZ1608N3R3LTD25](#) [MLZ1608N3R3LT000](#) [MLZ1608N150LT000](#)
[MLZ1608M150WTD25](#) [MLZ1608M3R3WTD25](#) [MLZ1608M3R3WT000](#) [MLZ1608M150WT000](#) [MLZ1608A1R5WT000](#)
[MLZ1608N1R5LT000](#) [B82432C1333K000](#) [PCMB053T-1R0MS](#) [PCMB053T-1R5MS](#) [PCMB104T-1R5MS](#) [CR32NP-100KC](#) [CR32NP-151KC](#) [CR32NP-180KC](#) [CR32NP-181KC](#) [CR32NP-1R5MC](#) [CR32NP-390KC](#) [CR32NP-3R9MC](#) [CR32NP-680KC](#) [CR32NP-820KC](#)
[CR32NP-8R2MC](#) [CR43NP-390KC](#) [CR43NP-560KC](#) [CR43NP-680KC](#) [CR54NP-181KC](#) [CR54NP-470LC](#) [CR54NP-820KC](#) [CR54NP-8R5MC](#)
[MGDQ4-00004-P](#) [MGDU1-00016-P](#) [MHL1ECTTP18NJ](#) [MHL1JCTTD12NJ](#) [PE-51506NL](#) [PE-53601NL](#) [PE-53630NL](#) [PE-53824SNLT](#) [PE-62892NL](#) [PE-92100NL](#) [PG0434.801NLT](#) [PG0936.113NLT](#) [PM06-2N7](#) [PM06-39NJ](#) [HC2LP-R47-R](#) [HC2-R47-R](#) [HC3-2R2-R](#) [HC8-1R2-R](#)