

Multilayer Chip Antenna – SLDA Series

Operating Temp. : -40°C~+85°C

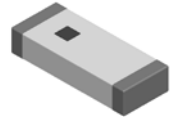

FEATURES

- Light weight, compact
- Wide bandwidth, low cost
- Built-in antenna with high gain

APPLICATIONS

- Bluetooth, Wireless LAN, Mobile TV
- Home RF system, etc.

PRODUCT IDENTIFICATION

| <u>SLDA</u> ① | <u>31</u> ② | <u>-2R800G</u> ③ | <u>-S1</u> ④ | <u>I</u> ⑤ | <u>F</u> ⑥ | | | | | | | | | | | | | | | | | | | | | | | | | | |
|--|-------------------------|---------------------|-----------------|--|-------------------------|--|--|--------------------------------|-------------|---|---------|-----------------------------------|---------|----|---------|----|---------|----|---------|----|---------|---|--|------------------|--|---------|---------------|--------|-----------|--------|-----------|
| ① | ② | ③ | ④ | ⑤ | ⑥ | | | | | | | | | | | | | | | | | | | | | | | | | | |
| <table border="1"> <thead> <tr> <th colspan="2">Type</th> </tr> </thead> <tbody> <tr> <td>SLDA</td> <td>Multilayer Chip Antenna</td> </tr> </tbody> </table> | | Type | | SLDA | Multilayer Chip Antenna | <table border="1"> <thead> <tr> <th colspan="2">External Dimensions (LxW) (mm)</th> </tr> </thead> <tbody> <tr> <td>31</td> <td>3.2x1.6</td> </tr> <tr> <td>52</td> <td>5.2x2.1</td> </tr> <tr> <td>62</td> <td>6.0x2.0</td> </tr> <tr> <td>72</td> <td>7.0x2.0</td> </tr> <tr> <td>81</td> <td>8.0x1.0</td> </tr> <tr> <td>92</td> <td>9.0x2.0</td> </tr> </tbody> </table> | | External Dimensions (LxW) (mm) | | 31 | 3.2x1.6 | 52 | 5.2x2.1 | 62 | 6.0x2.0 | 72 | 7.0x2.0 | 81 | 8.0x1.0 | 92 | 9.0x2.0 | <table border="1"> <thead> <tr> <th colspan="2">Center Frequency</th> </tr> </thead> <tbody> <tr> <th>Example</th> <th>Nominal Value</th> </tr> <tr> <td>2R800G</td> <td>2800.0MHz</td> </tr> <tr> <td>2R450G</td> <td>2450.0MHz</td> </tr> </tbody> </table> | | Center Frequency | | Example | Nominal Value | 2R800G | 2800.0MHz | 2R450G | 2450.0MHz |
| Type | | | | | | | | | | | | | | | | | | | | | | | | | | | | | | | |
| SLDA | Multilayer Chip Antenna | | | | | | | | | | | | | | | | | | | | | | | | | | | | | | |
| External Dimensions (LxW) (mm) | | | | | | | | | | | | | | | | | | | | | | | | | | | | | | | |
| 31 | 3.2x1.6 | | | | | | | | | | | | | | | | | | | | | | | | | | | | | | |
| 52 | 5.2x2.1 | | | | | | | | | | | | | | | | | | | | | | | | | | | | | | |
| 62 | 6.0x2.0 | | | | | | | | | | | | | | | | | | | | | | | | | | | | | | |
| 72 | 7.0x2.0 | | | | | | | | | | | | | | | | | | | | | | | | | | | | | | |
| 81 | 8.0x1.0 | | | | | | | | | | | | | | | | | | | | | | | | | | | | | | |
| 92 | 9.0x2.0 | | | | | | | | | | | | | | | | | | | | | | | | | | | | | | |
| Center Frequency | | | | | | | | | | | | | | | | | | | | | | | | | | | | | | | |
| Example | Nominal Value | | | | | | | | | | | | | | | | | | | | | | | | | | | | | | |
| 2R800G | 2800.0MHz | | | | | | | | | | | | | | | | | | | | | | | | | | | | | | |
| 2R450G | 2450.0MHz | | | | | | | | | | | | | | | | | | | | | | | | | | | | | | |
| <table border="1"> <thead> <tr> <th>Series Code</th> </tr> </thead> <tbody> <tr> <td>S1, 01, etc.</td> </tr> </tbody> </table> | | Series Code | S1, 01, etc. | <table border="1"> <thead> <tr> <th colspan="2">Packing</th> </tr> </thead> <tbody> <tr> <td>T</td> <td>Tape & Reel</td> </tr> </tbody> </table> | | Packing | | T | Tape & Reel | <table border="1"> <thead> <tr> <th>Hazardous Substance Free Products</th> </tr> </thead> <tbody> <tr> <td>F</td> </tr> </tbody> </table> | | Hazardous Substance Free Products | F | | | | | | | | | | | | | | | | | | |
| Series Code | | | | | | | | | | | | | | | | | | | | | | | | | | | | | | | |
| S1, 01, etc. | | | | | | | | | | | | | | | | | | | | | | | | | | | | | | | |
| Packing | | | | | | | | | | | | | | | | | | | | | | | | | | | | | | | |
| T | Tape & Reel | | | | | | | | | | | | | | | | | | | | | | | | | | | | | | |
| Hazardous Substance Free Products | | | | | | | | | | | | | | | | | | | | | | | | | | | | | | | |
| F | | | | | | | | | | | | | | | | | | | | | | | | | | | | | | | |

SHAPE AND LAND PATTERN

| Type: | Dimensions (mm) |
|--------------------------|-------------------|
| | |
| Type: SLDA21-2R450G-S1TF | Land Pattern (mm) |
| | |

SHAPE AND DIMENSIONS

| Series | A | B | C | D | E | F | G | H | I | J |
|--------|---------|---------|---------|---------|---------|---------|---------|---------|-----|---------|
| SLDA31 | 3.2±0.2 | 1.6±0.2 | 1.2±0.2 | 0.5±0.2 | 1.6±0.2 | 0.8±0.2 | 0.8±0.2 | 2.2±0.2 | 1.4 | 1.6±0.2 |
| SLDA52 | 5.2±0.2 | 2.1±0.2 | 1.0±0.2 | 0.5±0.2 | 2.3±0.2 | 1.5±0.2 | 1.0±0.2 | 4.0±0.2 | 1.4 | 2.3±0.2 |
| SLDA62 | 6.0±0.2 | 2.0±0.2 | 1.0±0.2 | 0.5±0.2 | 2.2±0.2 | 1.5±0.2 | 1.0±0.2 | 5.0±0.2 | 1.4 | 2.2±0.2 |
| SLDA72 | 7.0±0.2 | 2.0±0.2 | 1.0±0.2 | 0.5±0.2 | 2.2±0.2 | 1.5±0.2 | 1.0±0.2 | 6.0±0.2 | 1.4 | 2.2±0.2 |
| SLDA81 | 8.0±0.2 | 1.0±0.2 | 1.0±0.2 | 0.5±0.2 | 1.5±0.2 | 1.5±0.2 | 1.0±0.2 | 7.0±0.2 | 1.4 | 1.5±0.2 |
| SLDA92 | 9.0±0.2 | 2.0±0.2 | 1.0±0.2 | 0.5±0.2 | 2.2±0.2 | 1.5±0.2 | 1.0±0.2 | 8.0±0.2 | 1.4 | 2.2±0.2 |

TERINAL-CONFIGURATION



| No. | Terminal Name | No. | Terminal Name |
|-----|---------------|-----|---------------|
| (1) | Feeding Point | (2) | NC |

EVALUATION BOARD

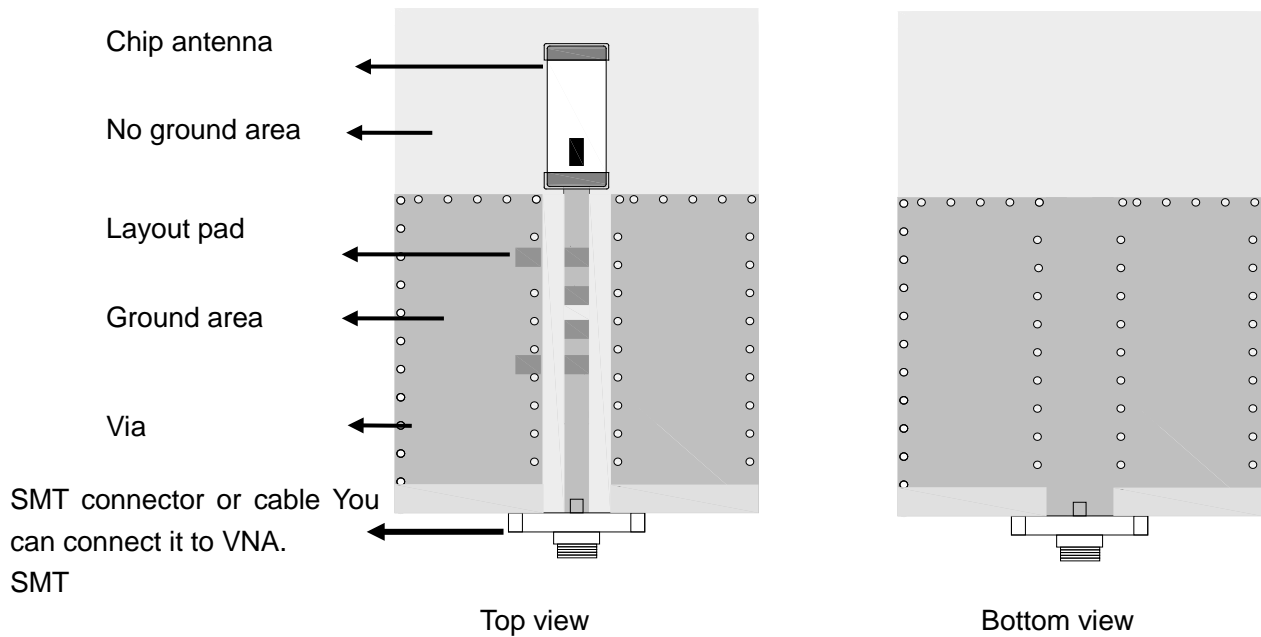

APPLICATION GUIDE

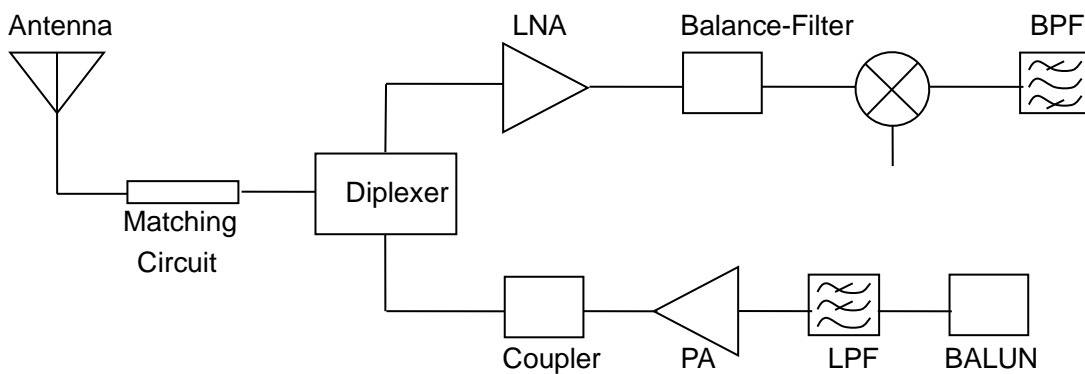

SPECIFICATIONS

SLDA31 TYPE

| Part Number | Band Width | Peak Gain | Average Gain | VSWR | Impedance | Power Capacity |
|--------------------|------------|-------------------------|-------------------------|-------|-----------|----------------|
| | MHz | V-XZ | V-XZ | In BW | Ω | W |
| SLDA31-2R800G-S1TF | ≥ 100 | 0.5dBi Typ. | -1dBi Typ. | <2 | 50 | 3 |
| SLDA31-2R400G-S1TF | ≥ 100 | 2.5dB @ (XZ-total) | -1.5dB @ (XZ-total) | <2 | 50 | 2 |
| SLDA31-2R450G-S2TF | ≥ 100 | 2.5dBi @ (XZ-total) | 0.5dBi @ (XZ-total) | <2 | 50 | 2 |

SLDA52 TYPE

| Part Number | Band Width | Peak Gain | Average Gain | VSWR | Impedance | Power Capacity |
|--------------------|------------|-------------|--------------|-------|-----------|----------------|
| | MHz | V-XZ | V-XZ | In BW | Ω | W |
| SLDA52-2R510G-S1TF | ≥ 200 | 2.5dBi Typ. | 0.5dBi Typ. | <2 | 50 | |
| SLDA52-2R540G-S1TF | ≥ 200 | 2.5dBi Typ. | 0.5dBi Typ. | <2 | 50 | |

SLDA62 TYPE

| Part Number | Band Width | Peak Gain | Average Gain | VSWR | Impedance | Power Capacity |
|--------------------|------------|-------------|--------------|-------|-----------|----------------|
| | MHz | V-XZ | V-XZ | In BW | Ω | W |
| SLDA62-2R640G-01TF | ≥ 200 | 2.6dBi Typ. | 0.7dBi Typ. | <2 | 50 | 3 |

SLDA72 TYPE

| Part Number | Band Width | Peak Gain | Average Gain | VSWR | Impedance | Power Capacity |
|--------------------|------------|-------------|--------------|-------|-----------|----------------|
| | MHz | V-XZ | V-XZ | In BW | Ω | W |
| SLDA72-2R470G-S1TF | ≥ 200 | 2.7dBi Typ. | 1.0dBi Typ. | <2 | 50 | 3 |

SLDA81 TYPE

| Part Number | Band Width | Peak Gain | Average Gain | VSWR | Impedance | Power Capacity |
|--------------------|------------|-------------|--------------|-------|-----------|----------------|
| | MHz | V-XZ | V-XZ | In BW | Ω | W |
| SLDA81-3R010G-S1TF | ≥ 200 | 2.0dBi Typ. | 0.5dBi Typ. | <2 | 50 | 3 |

SLDA92 TYPE

| Part Number | Band Width | Peak Gain | Average Gain | VSWR | Impedance | Power Capacity |
|--------------------|------------|-------------|--------------|-------|-----------|----------------|
| | MHz | V-XZ | V-XZ | In BW | Ω | W |
| SLDA92-2R660G-S1TF | ≥ 200 | 3.0dBi Typ. | 1.0dBi Typ. | <2 | 50 | 3 |

※Frequency will be changed with layout of PCB. Please contact us for appropriate design.

RETURN LOSS

SLDA31-2R800G-S1TF

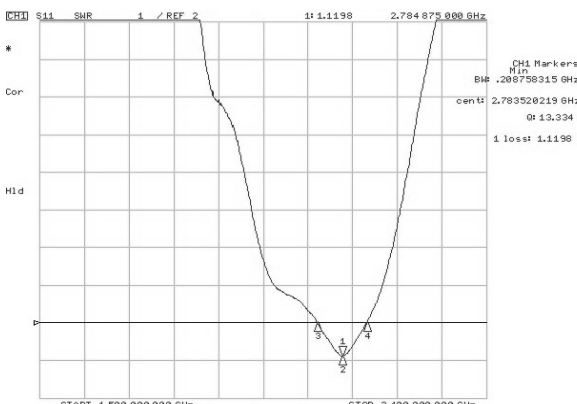

SLDA31-2R400G-S1TF

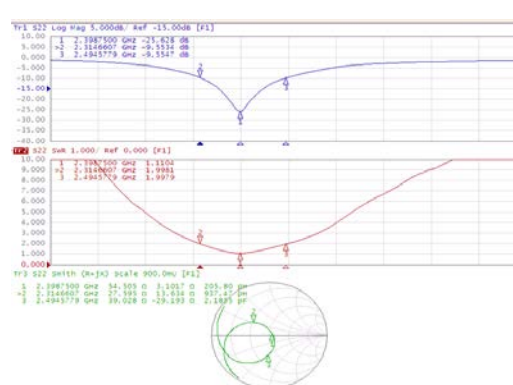

RETURN LOSS

SLDA31-2R450G-S2TF

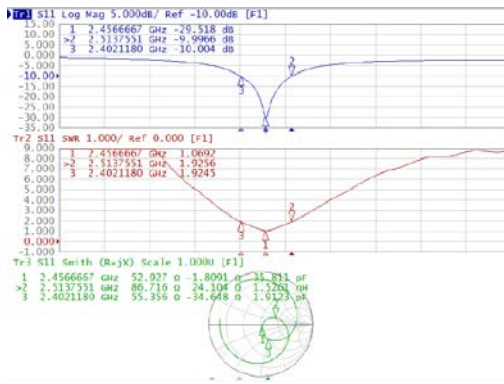

SLDA52-2R510G-S1TF

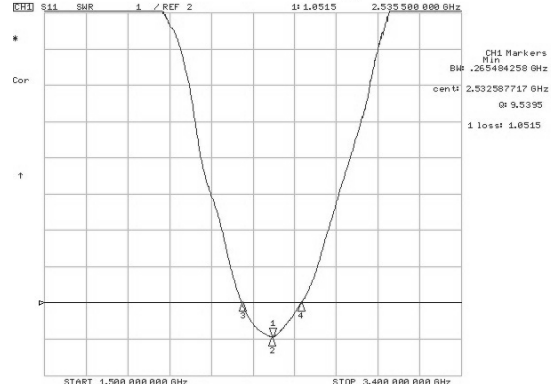

SLDA52-2R540G-S1TF

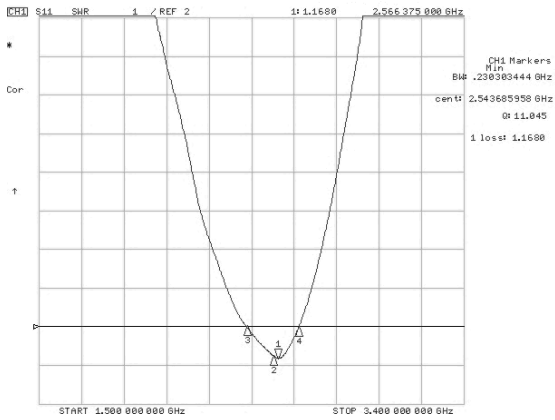

SLDA62-2R640G-01TF

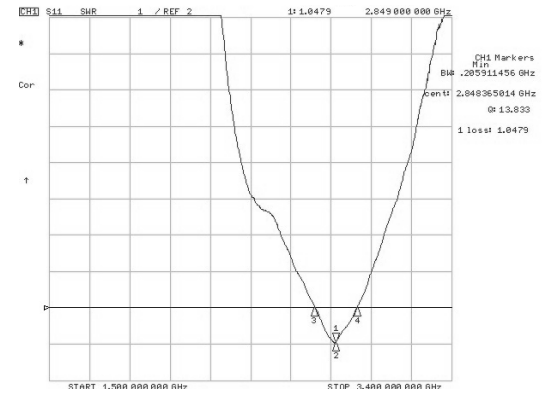

SLDA72-2R470G-S1TF

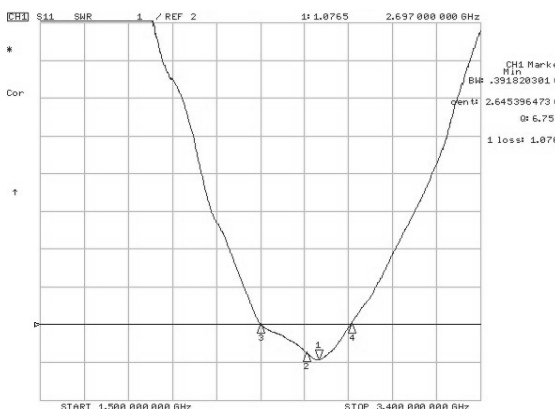

SLDA81-3R010G-S1TF

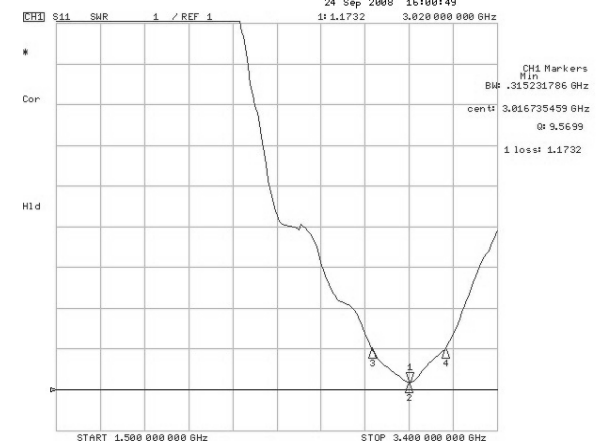

SLDA92-2R660G-S1TF

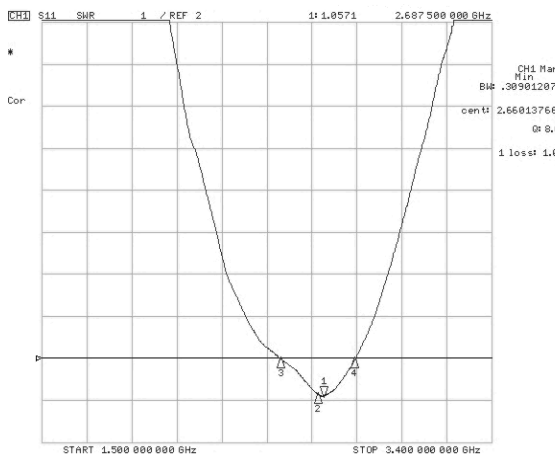

X-ON Electronics

Largest Supplier of Electrical and Electronic Components

Click to view similar products for [Antennas](#) category:

Click to view products by [Sunlord](#) manufacturer:

Other Similar products are found below :

[GAN30084EU](#) [930-033-R](#) [EXE902SM](#) [APAMPG-117](#) [MAF94383](#) [W6102B0100](#) [SPDA17RP918](#) [A09-F5NF-M](#) [RGFRA1903041A1T](#) [108-00016-050](#) [W3921B0100](#) [SIMNA-868](#) [SIMNA-915](#) [SIMNA-433](#) [W1049B090](#) [TRABT1560](#) [A75-001](#) [W3118A](#) [WTL2449CQ1-FRSMM](#) [CPL9C](#) [0600-00060](#) [GD5W-28P-NF](#) [MA9-7N](#) [GD53-25](#) [C37](#) [MAF94051](#) [FRX380](#) [MA9-5N](#) [B1322NR](#) [QWFTB120](#) [MAF94271](#) [MAF94300](#) [GPSMB301](#) [FG4403](#) [PSQ24495-91RSM](#) [MIKROE-2393](#) [DA5-32RADOME](#) [5200227](#) [GPSCPMM00](#) [W1049B030](#) [SPDA17RP918](#) [GPSCP00](#) [AN 303](#) [ANTDOM-05-01-WPM](#) [EXW30BNX](#) [OSCAR1A/5M/SMAM/S/S/31](#) [ALPHA4A/1M/SMAM/S/S/26](#) [OSCAR1A/10M/SMAM/S/S/31](#) [OSCAR40/5M/LL/SMAM/S/S/33](#) [OSCAR40/10M/LL/SMAM/S/S/33](#)