

SPECIFICATIONS

Customer	
Product Name	Multilayer Chip Diplexer
Sunlord Part Number	SLFD18-5R950G-07T
Customer Part Number	

New Released, Revised]

SPEC No.: **SLFD190000**

Rev.	Effective Date	Changed Contents	Change Reasons	Approved By
01	/	New release	/	Hai Guo

【 This SPEC is total 8 pages including specifications 】

【 ROHS, Halogen-Free and SVHC Compliant Parts 】

Approved By	Checked By	Issued By

Shenzhen Sunlord Electronics Co., Ltd.

Address: Sunlord Industrial Park, Dafuyuan Industrial Zone, Baoan, Shenzhen, China 518110

Tel: 0086-755-29832660 Fax: 0086-755-82269029 E-Mail: sunlord@sunlordinc.com

【 For Customer approval Only 】

Date: _____

Qualification Status: Full Restricted Rejected

Approved By	Verified By	Re-checked By	Checked By

Comments:

Caution

All products listed in this specification are developed, designed and intended for use in general electronics equipment. The products are not designed or warranted to meet the requirements of the applications listed below, whose performance and/or quality require especially high reliability, or whose failure, malfunction or trouble might directly cause damage to society, person, or property. Please understand that we are not responsible for any damage or liability caused by use of the products in any of the applications below. Please contact us for more details if you intend to use our products in the following applications.

1. Aircraft equipment
2. Aerospace equipment
3. Undersea equipment
4. nuclear control equipment
5. military equipment
6. Power plant equipment
7. Medical equipment
8. Transportation equipment (automobiles, trains, ships,etc.)
9. Traffic signal equipment
10. Disaster prevention / crime prevention equipment
11. Data-processing equipment
12. Applications of similar complexity or with reliability requirements comparable to the applications listed in the above

1. Scope

This specification applies to SLFD18-5R950G-07T of Multilayer Chip Diplexer.

2. Product Description and Identification (Part Number)

- 1) Description
Multi-layer Chip Diplexer
- 2) Product Identification (Part Number)

SLFD 18 5R950G 07 I
 ① ② ③ ④ ⑤

①	Type
SLFD	Multilayer Chip Diplexer

②	External Dimensions (LxW) (mm)
18	1.6 x 0.8

③	Center Frequency
5R950G	5950.0 MHz

④	Series Code
	07

⑤	Packing
T	Tape Carrier Package

3. Electrical Characteristics

Part Number	SLFD18-5R950G-07T	
Application	Low Band	High Band
Bandwidth(BW)	2400~2500 MHz	4900~5950 MHz
Max. IL in BW (@25°C)	0.4 dB max	0.6 dB max
Attenuation(Absolute value)	21 dB min. at 4800~5000MHz 23 dB min. at 5000~5950MHz 25 dB min. at 7200~7500MHz	26 dB min. at 824~2170MHz 30 dB min. at 2400~2700MHz 20 dB min. at 9800~11900MHz
Max. RL in BW (@25°C)	15 dB min	12 dB min
Characteristic Impedance (Nom.)	Complex Conjugate to IC chipset.	

- a) Operating and storage temperature range (individual chip without packing): -40°C~ +85°C.
- b) Storage temperature range (packaging conditions): -10°C~ +40°C and RH 70% (Max.).
- c) Test equipment: Network Analyzer:E5071C.
- d) Electrical Performance: See Fig. 3-1.

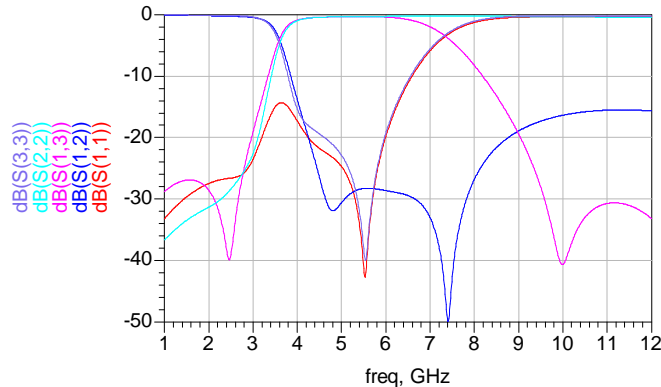

Fig. 3-1

4. Shape and Dimensions

1) Dimensions and terminal configuration: See Fig. 4-1

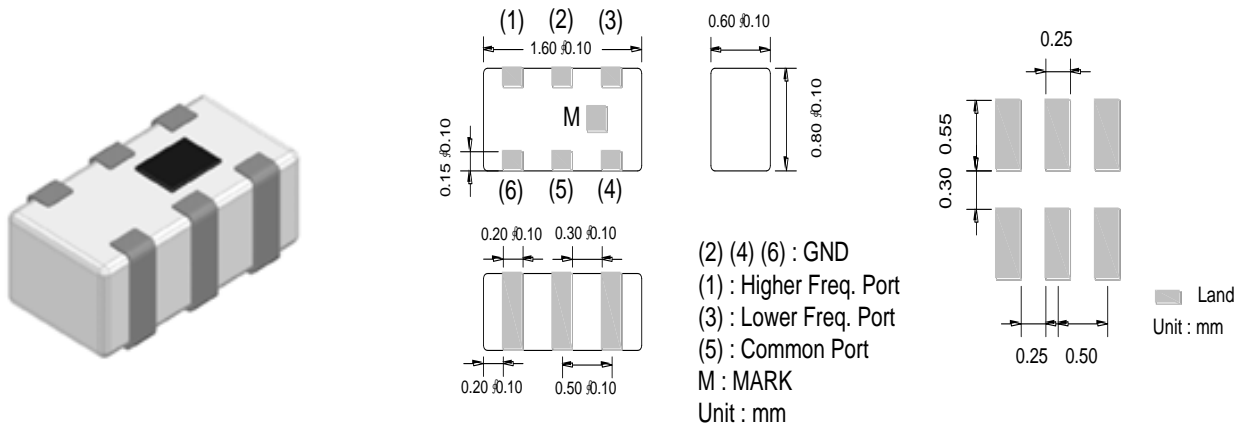
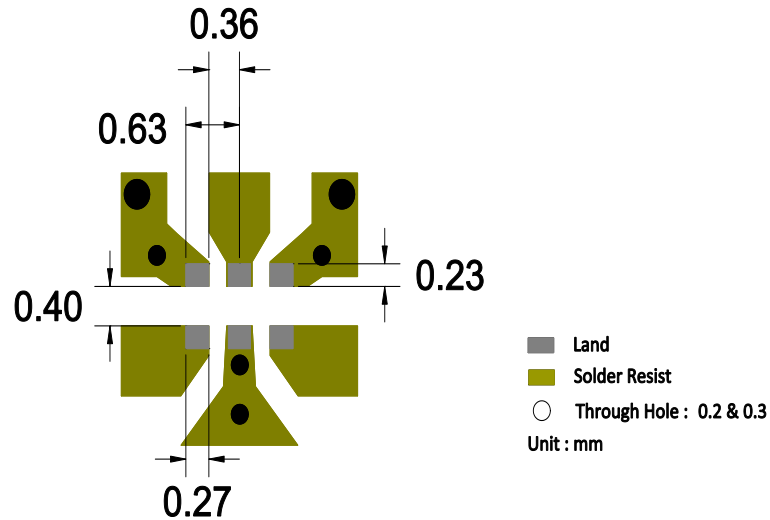

Fig. 4-1

2) Recommended Land Pattern: See Fig.4-2



* Line width should be designed to match 50 Ω characteristic impedance, depending on PCB material and thickness.

5. Test and Measurement Procedures

5.1 Test Conditions

Unless otherwise specified, the standard atmospheric conditions for measurement/test as:

- a. Ambient Temperature: 20±15°C
- b. Relative Humidity: 65±20%
- c. Air Pressure: 86 KPa to 106 KPa

If any doubt on the results, measurements/tests should be made within the following limits:

- a. Ambient Temperature: 20±2°C
- b. Relative Humidity: 65±5%
- c. Air Pressure: 86KPa to 106 KPa

5.2 Visual Examination

- a. Inspection Equipment: 20 X magnifier

5.3 Reliability Test

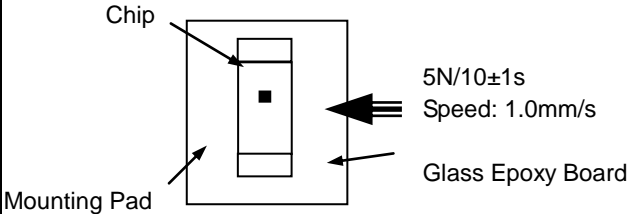
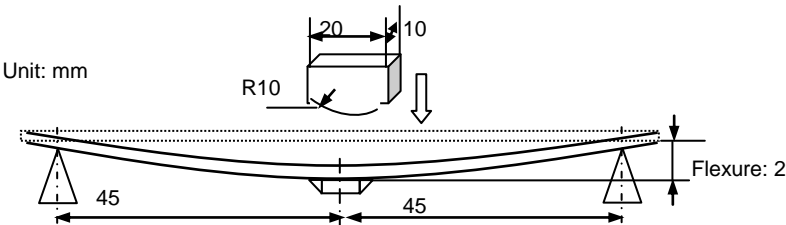
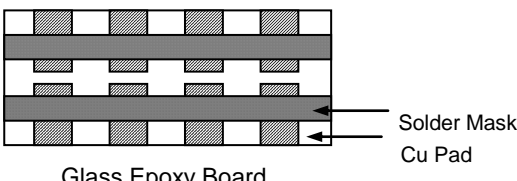
Items	Requirements	Test Methods and Remarks
<p>5.3.1 Terminal Strength</p>	<p>No visible mechanical damage.</p>	<p>① Solder the inductor to the testing jig (glass epoxy board shown as the following figure) using leadfree solder. Then apply a force in the direction of the arrow. ② 5N force for 1608 series. ③ Keep time: 10±1sec.</p> 
<p>5.3.2 Resistance to Flexure</p>	<p>No visible mechanical damage.</p>	<p>① Solder the chip to the test jig (glass epoxy board) using a leadfree solder. Then apply a force in the direction shown as the following figure. Solder the chip to the test jig (glass epoxy board) using leadfree solder. Then apply a force in the direction. ② Flexure: 2mm ③ Pressurizing Speed: 0.5mm/sec ④ Keep time: ≥30 sec</p> 
<p>5.3.3 Vibration</p>	<p>No visible mechanical damage.</p>	<p>① Solder the chip to the testing jig (glass epoxy board shown as the following figure) using leadfree solder. ② The chip shall be subjected to a simple harmonic motion having total amplitude of 1.5mm, the frequency being varied uniformly between the approximate limits of 10 and 55 Hz. ③ The frequency range from 10 to 55 Hz and return to 10 Hz shall be traversed in approximately 1 minute. This motion shall be applied for a period of 2 hours in each 3 mutually perpendicular directions (total of 6 hours).</p> 
<p>5.3.4 Dropping</p>	<p>No visible mechanical damage.</p>	<p>Drop the chip 10 times on a concrete floor from a height of 100 cm.</p>
<p>5.3.5 Solderability</p>	<p>① No visible mechanical damage. ② Wetting shall be exceeded 75% coverage.</p>	<p>① Solder temperature: 240±2°C ② Duration: 3sec ③ Solder: Sn/3.0Ag/0.5Cu ④ Flux: 25% Resin and 75% ethanol in weight</p>
<p>5.3.6 Resistance to Soldering Heat</p>	<p>No visible mechanical damage.</p>	<p>① Solder temperature: 260±5°C ② Duration: 5 sec ③ Solder: Sn/3.0Ag/0.5Cu ④ Flux: 25% Resin and 75% ethanol in weight ⑤ The chip shall be stabilized at normal condition for 1~2 hours before measuring.</p>

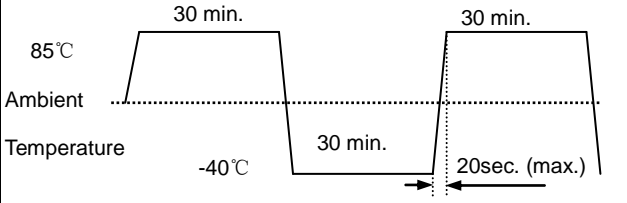
<p>5.3.7 Thermal Shock</p>	<p>① No visible mechanical damage. ② Satisfy electrical Characteristic.</p>	<p>① Temperature and time: -40°C for 30 ± 3 min \rightarrow 85°C for 30 ± 3 min ② Transforming interval: Max. 20 sec. ③ Tested cycle: 100 cycles ④ The chip shall be stabilized at normal condition for 1~2 hours before measuring.</p> 
<p>5.3.8 Damp Heat (Steady States)</p>	<p>① No visible mechanical damage. ② Satisfy electrical Characteristic.</p>	<p>① Temperature: $60\pm 2^{\circ}\text{C}$ ② Humidity: 90% to 95% RH ③ Duration: 500^{+24} hours ④ The chip shall be stabilized at normal condition for 1~2 hours before measuring.</p>
<p>5.3.9 Resistance to High temperature</p>	<p>① No visible mechanical damage. ② Satisfy electrical Characteristic.</p>	<p>① Temperature: $85\pm 2^{\circ}\text{C}$ ② Duration: 500^{+24} hours ③ The chip shall be stabilized at normal condition for 1~2 hours before measuring.</p>

6. Packaging and Storage

6.1 Packaging

There is one type of packaging for the Diplexer. Please specify the packing code when ordering.

6.1.1 Tape Carrier Packaging:

Packaging code: T

- a. Tape carrier packaging are specified in attached figure **Fig. 6.1-1-3**
- b. Tape carrier packaging quantity please see the following table:

Type	1608[0603]
Tape	Paper Tape
Quantity	4K

(1) Taping Drawings (Unit: mm)

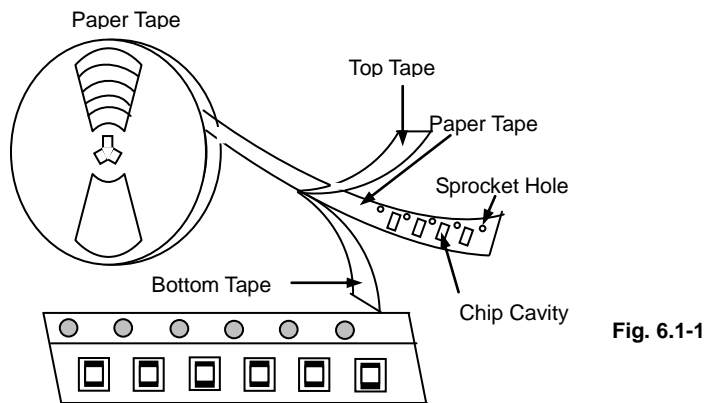

Remark: The sprocket holes are to the right as the tape is pulled toward the user.

(2) Taping Dimensions (Unit: mm)

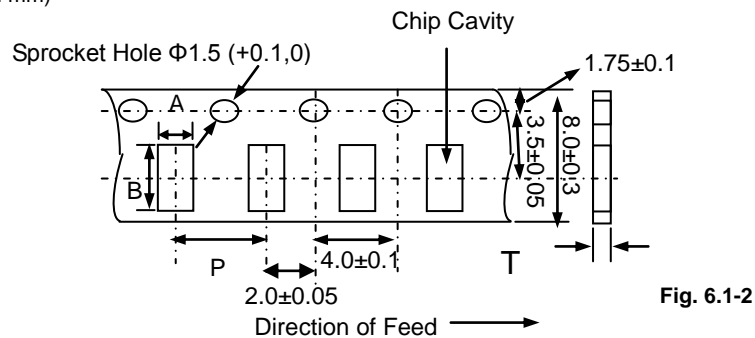

Type	Chip Thickness	A	B	P	T max
SLFD18	0.60±0.10	1.00±0.10	1.80±0.10	4.0±0.10	0.75

(3) Reel Dimensions (Unit: mm)

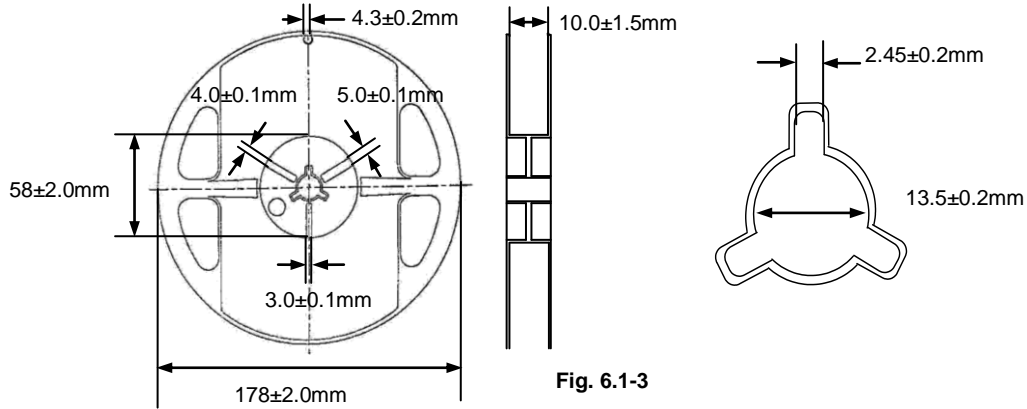

Fig. 6.1-3

6.2 Storage

- a. The solderability of the external electrode may be deteriorated if packages are stored where they are exposed to high humidity. Package must be stored at 40°C or less and 70% RH or less.
- b. The solderability of the external electrode may be deteriorated if packages are stored where they are exposed to dust of harmful gas (e.g. HCl, sulfurous gas of H₂S).
- c. Packaging material may be deformed if package are stored where they are exposed to heat of direct sunlight.
- d. Solderability specified in **Clause 5.3.6** shall be guaranteed for 6 months from the date of delivery on condition that they are stored at the environment specified in **Clause 3**. For those parts, which passed more than 6 months shall be checked solder-ability before use.

7. Recommended Soldering Technologies

7.1 Re-flowing Profile

- △ Preheat condition: 150 ~200°C/60~120sec.
- △ Allowed time above 217°C: 60~90sec.
- △ Max temp: 260°C
- △ Max time at max temp: 10sec.
- △ Solder paste: Sn/3.0Ag/0.5Cu
- △ Allowed Reflow time: 2x max

[Note: The reflow profile in the above table is only for qualification and is not meant to specify board assembly profiles. Actual board assembly profiles must be based on the customer's specific board design, solder paste and process, and should not exceed the parameters as the Reflow profile shows.]

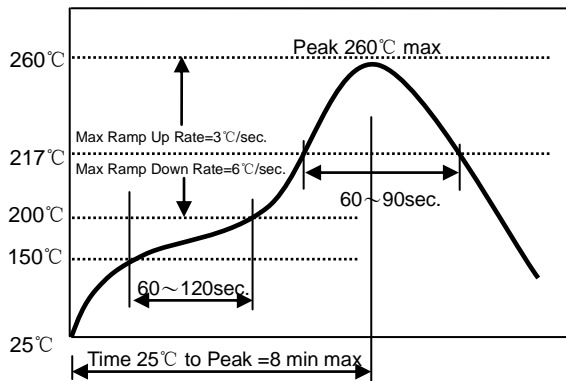

7.2 Iron Soldering Profile

- △ Iron soldering power: Max.30W
- △ Pre-heating: 150 °C / 60 sec.
- △ Soldering Tip temperature: 350°C Max.
- △ Soldering time: 3 sec Max.
- △ Solder paste: Sn/3.0Ag/0.5Cu
- △ Max.1 times for iron soldering

[Note: Take care not to apply the tip of the soldering iron to the terminal electrodes.]

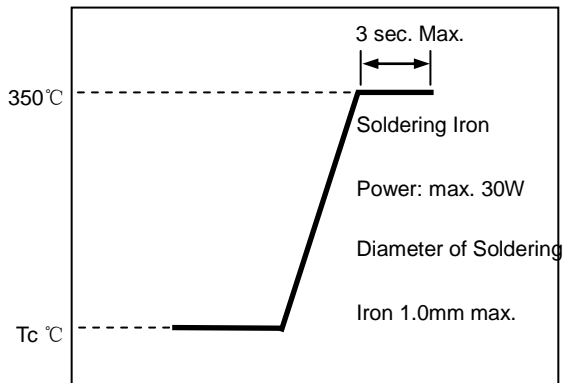

8. Supplier Information

a) Supplier:

Shenzhen Sunlord Electronics Co., Ltd.

b) Manufacturer:

Shenzhen Sunlord Electronics Co., Ltd.

c) Manufacturing Address:

Sunlord Industrial Park, Dafuyuan Industrial Zone, Guanlan, Shenzhen, China**Zip: 518110**

X-ON Electronics

Largest Supplier of Electrical and Electronic Components

Click to view similar products for [Signal Conditioning](#) category:

Click to view products by [Sunlord](#) manufacturer:

Other Similar products are found below :

[MAPDCC0004](#) [PD0409J5050S2HF](#) [880157](#) [HHS-109-PIN](#) [DC1417J5005AHF](#) [DC4859J5005AHF](#) [AFS14A30-2185.00-T3](#) [AFS14A35-1591.50-T3](#) [DS-323-PIN](#) [DSS-313-PIN](#) [B39321R801H210](#) [B39321R821H210](#) [B39921B4317P810](#) [1A0220-3](#) [2089-6207-00](#) [JP510S](#) [LFB212G45SG8C341](#) [LFB322G45SN1A504](#) [LFL182G45TC3B746](#) [SF2159E](#) [30057](#) [1P510S](#) [CER0813B](#) [3A325](#) [40287](#) [41180](#) [ATB3225-75032NCT](#) [B69842N5807A150](#) [BD0810N50100AHF](#) [BD2326L50200AHF](#) [BD2425J50200AHF](#) [HMC189AMS8TR](#) [C5060J5003AHF](#) [JHS-114-PIN](#) [JP503AS](#) [DC0710J5005AHF](#) [DC2327J5005AHF](#) [DC3338J5005AHF](#) [43020](#) [LFB2H2G60BB1C106](#) [LFL15869MTC1B787](#) [X3C19F1-20S](#) [XC3500P-20S](#) [10013-20](#) [SF2081E](#) [SF2194E](#) [SF2238E](#) [CDBLB455KCAX39-B0](#) [RF1353C](#) [PD0922J5050D2HF](#)