

SAW Duplexer

for B2 / Unbalanced / LR / 1612

Pinnacle PN: SA021612G88AT

Key Feature:

✓ High Output Power

✓ Low Insertion Loss

1 Description

SA0216121G88AT is a high-performance Surface Acoustic Wave (SAW) duplexer optimized for FDD LTE Band 2 applications operating in the range of 1.850-1.910GHz / 1.930-1.990 GHz. It is designed to provide low insertion loss in Band 2, good isolation between TX and RX ports, and high rejection in the adjacent cellular bands for mobile devices.

SA0216121G88AT uses advanced Chip Scale Package (CSP) technology and is housed in an industry-standard, 8-pin 1.6mm x 1.2 mm package with a low profile of 0.6 mm max.

2 Package & Dimensions:

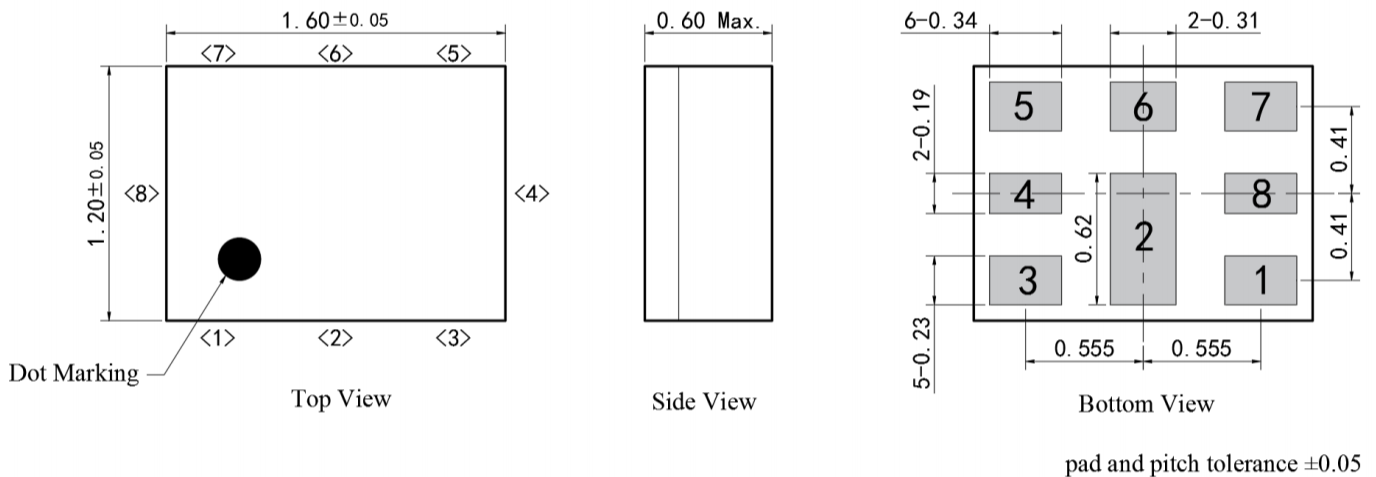

Figure 1: Drawing of Package with each tolerance range

3 Test Circuit

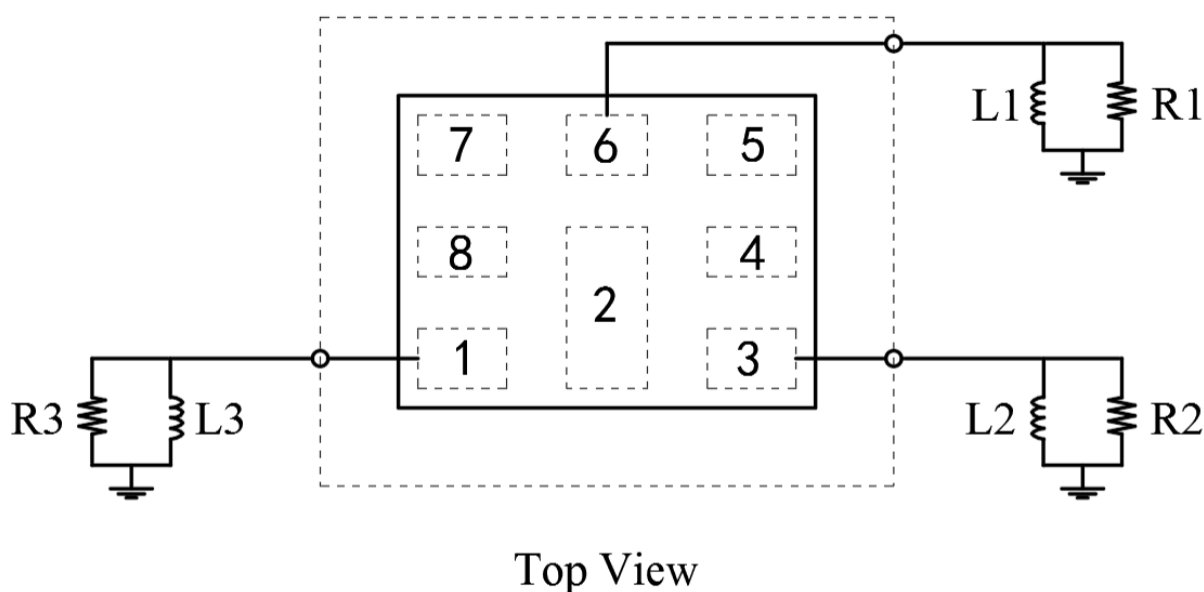

Figure 2: Schematic of matching circuit. External matching components required as below.

R1: 50 Ohm	L1: 3.0 nH
R2: 50 Ohm	L2: 15.0 nH
R3: 50 Ohm	L3: 8.2 nH

4 Pin configuration

- 1 RX
- 3 TX
- 6 Ant
- 2, 4, 5,7,8 To be grounded

5 Absolute Maximum Ratings

Parameter	Rating	Unit
Operating Temperature	-30 to +85	°C
Storage Temperature	-40 to +85	°C
Input Power@ input port	Pin=31dBm Continuous wave for 5000h@+50°C	dBm
Approximate weight	2.3	mg
Moisture Sensitivity Levels	3	MSL
Maximum DC Voltage	3	V

6 Recommended Soldering Profile

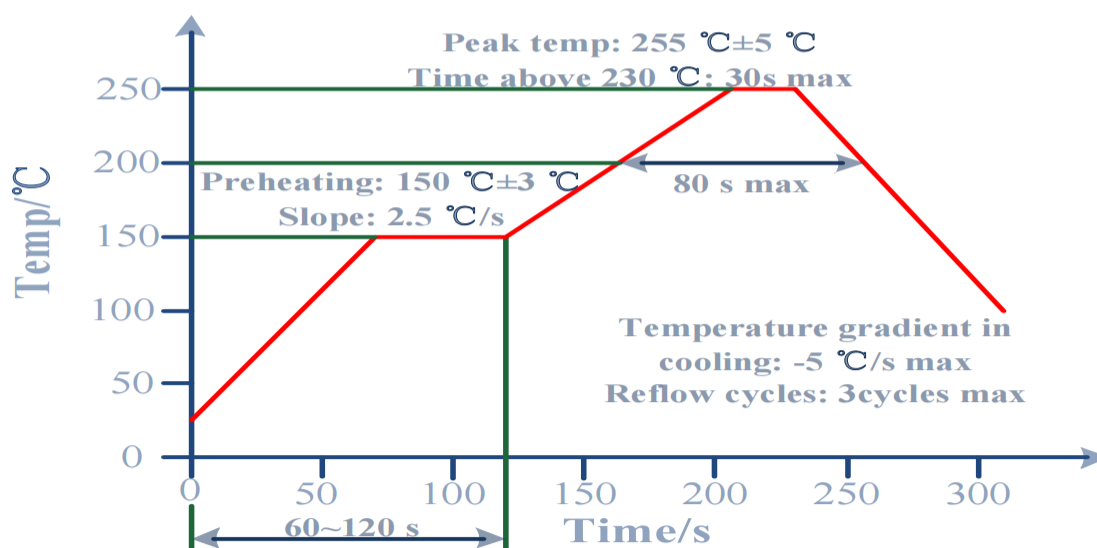

Figure 3: Recommended Reflow profile for convection and infrared soldering -lead-free solder.

7 Electrical Specifications

(At $T_a=25^\circ\text{C}$, unless otherwise specified, as measured on the evaluation board of SA0216121G88AT with feed line loss de-embedded.)

TX→ANT						
Parameter		Min	Typ.	Max	Unit	
Insertion Loss	1850 - 1910 MHz	-	1.6	2.6	dB	
Passband Ripple	1850 - 1910 MHz	-	1.2	2.0	dB	
Attenuation	10 - 728 MHz	36	42	-	dB	
	728 - 768 MHz	35	40	-	dB	
	859 - 894 MHz	34	38	-	dB	
	1226 - 1250 MHz	31	35	-	dB	
	1559 - 1606 MHz	35	40	-	dB	
	1606 - 1680 MHz	30	35	-	dB	
	1930 - 1990 MHz	40	52	-	dB	
	2110 - 2200 MHz	35	40	-	dB	
	2350 - 2360 MHz	25	30	-	dB	
	2400 - 2700 MHz	25	30	-	dB	
	3700 - 3830 MHz	25	30	-	dB	
	5150 - 5455 MHz	12	20	-	dB	
	5520 - 5845 MHz	8	15	-		
VSWR(TX)	1850 - 1910 MHz	-	1.6	2.1	-	
VSWR(ANT)	1850 - 1910 MHz	-	1.6	2.1	-	

ANT→RX						
Parameter	Conditions	Min	Typ.	Max	Unit	
Insertion Loss	1930 - 1990 MHz	-	2.2	3.0	dB	
Passband Ripple	1930 - 1990 MHz	-	1.5	2.0	dB	
Attenuation	699 - 716 MHz	42	48	-	dB	
	777 - 787 MHz	41	46	-	dB	
	814 - 849 MHz	40	45	-	dB	
	1850 - 1915 MHz	40	52	-	dB	
	2055 - 2080 MHz	30	40	-	dB	
	2305 - 2315 MHz	35	42	-	dB	
	2400 - 2500 MHz	36	44	-	dB	
	4900 - 5950 MHz	42	52	-	dB	
	5610 - 5845 MHz	42	52	-	dB	
	5790 - 5985 MHz	42	52	-	dB	
	7720 - 7980 MHz	40	50	-	dB	
VSWR(ANT)	1930 - 1990 MHz	-	1.7	2.2	-	
VSWR(RX)	1930 - 1990 MHz	-	1.6	2.1	-	

TX→RX					
Parameter	Conditions	Min	Typ.	Max	Unit
Isolation	1850 -1910 MHz	53	56	-	dB
	1930 - 1990 MHz	54	57	-	dB
	1574 - 1577 MHz	40	50	-	dB
	3700 - 3820 MHz	35	45	-	dB
	5550 - 5850 MHz	30	40	-	dB

8 Frequency Characteristics

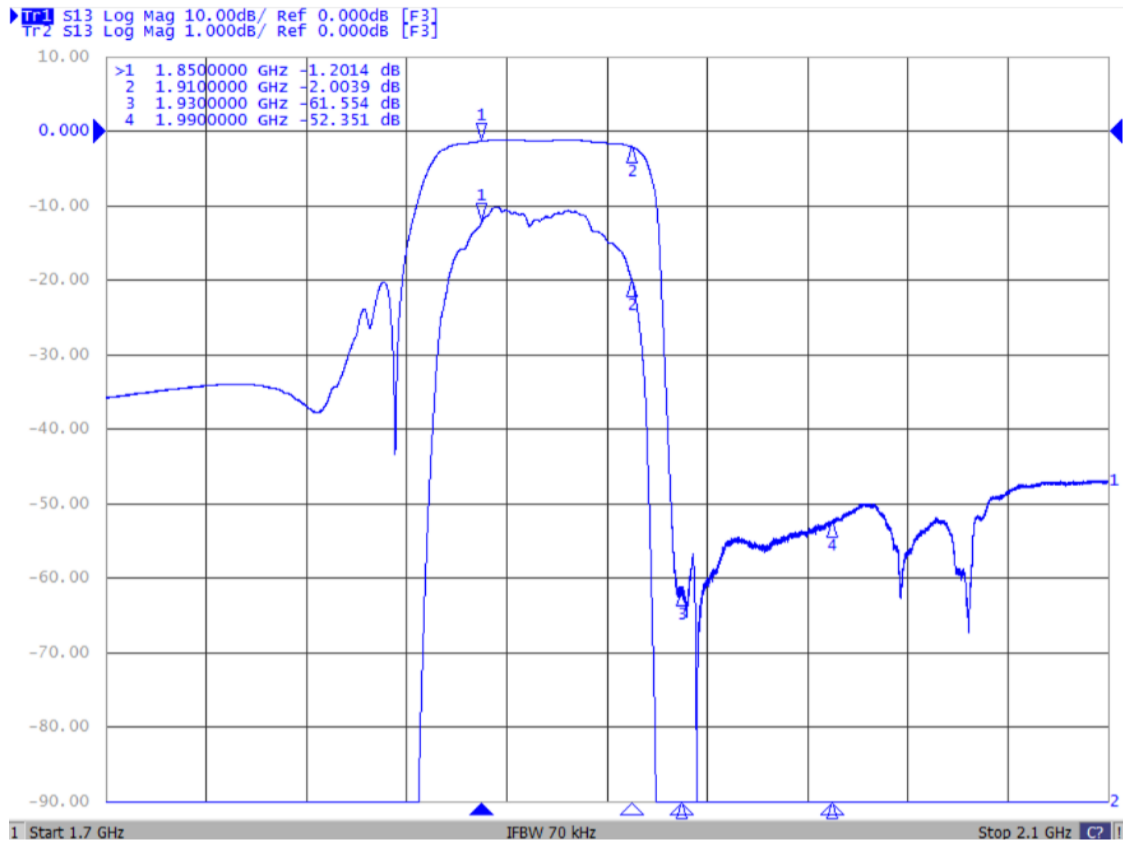

Figure 4: TX→ANT

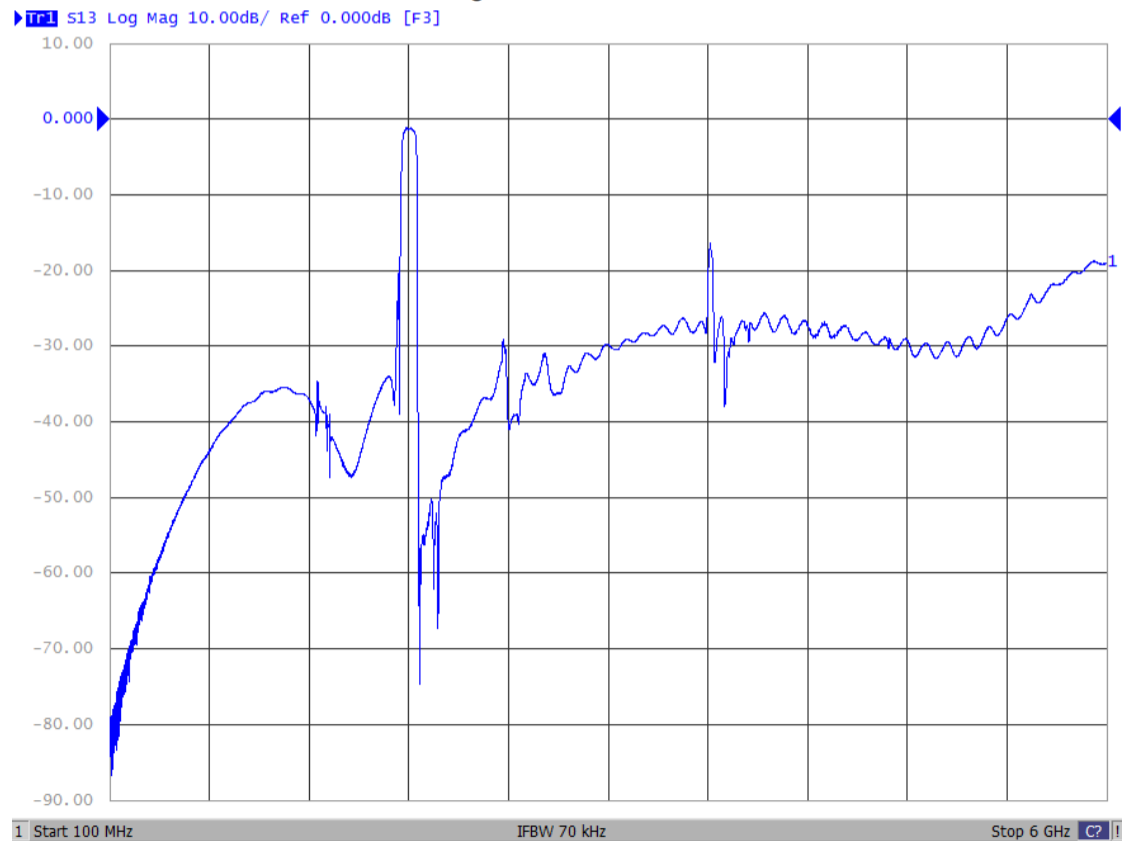

Figure 5: TX→ANT (Wide Band)

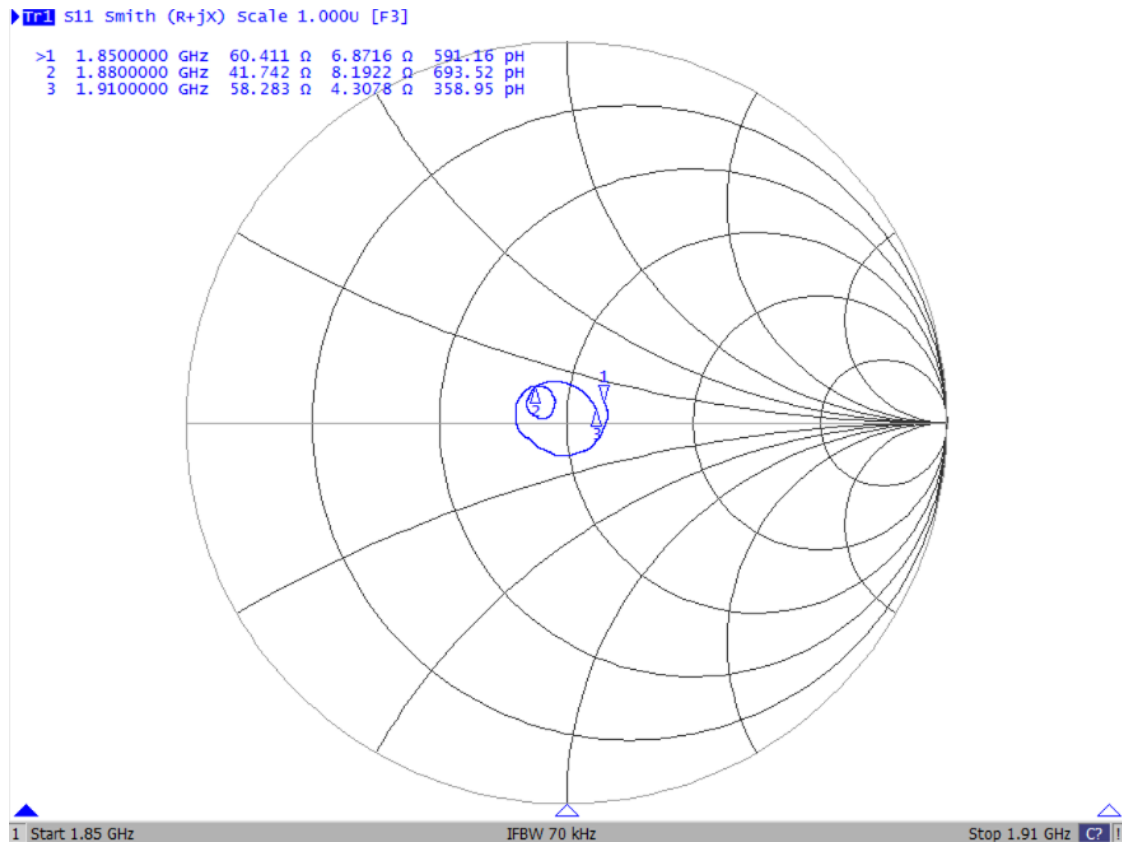

Figure 6: Smith for ANT

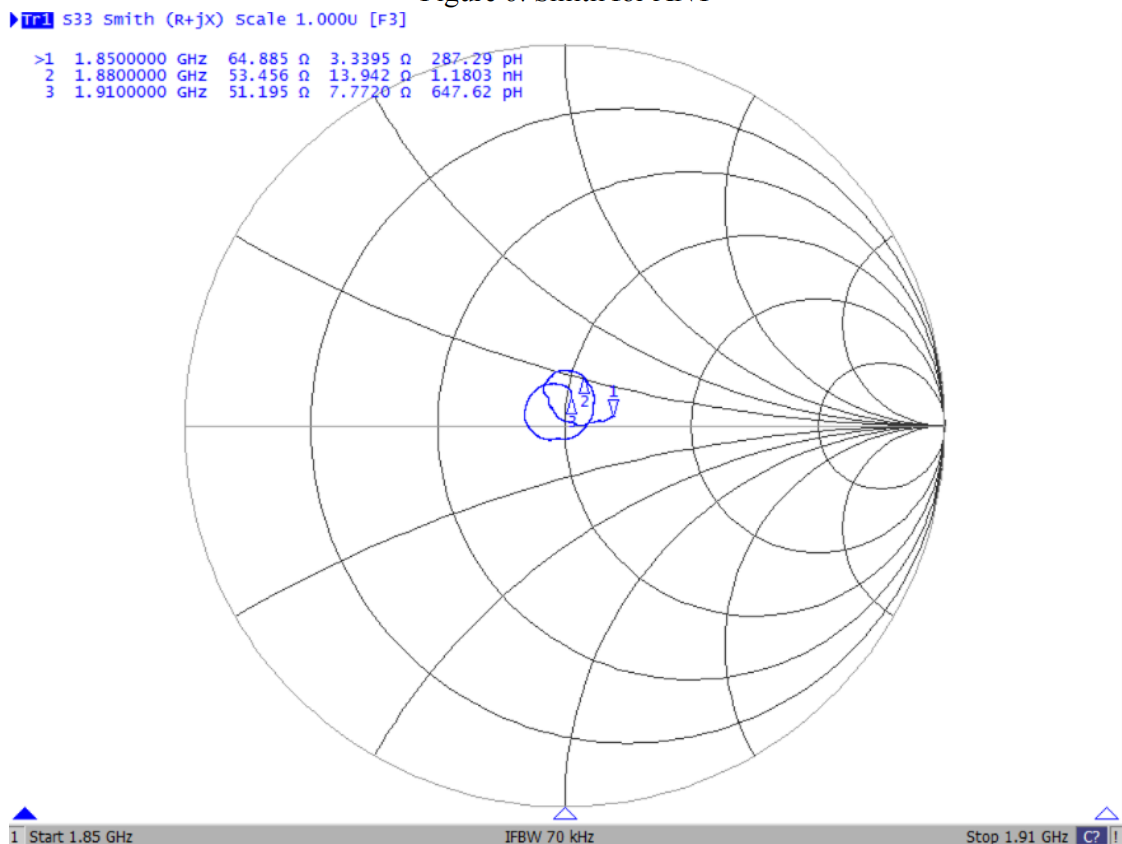

Figure7: Smith for TX

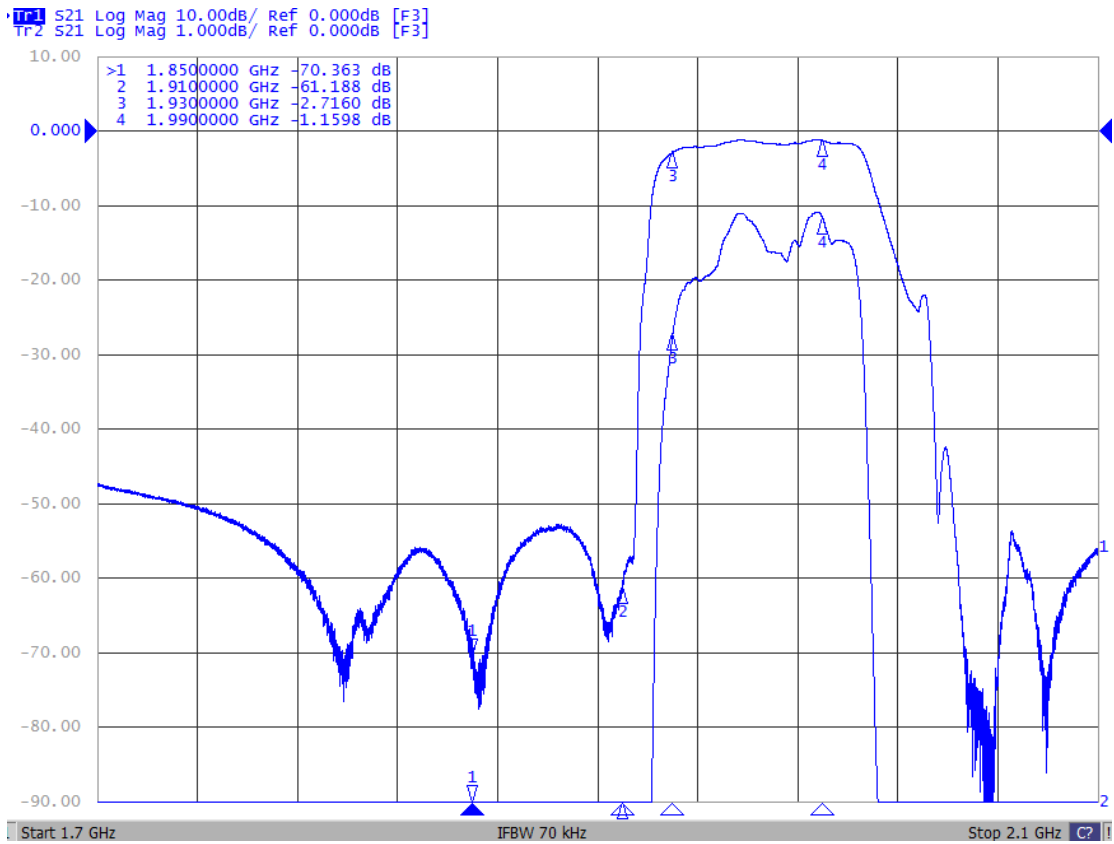

Figure 8: ANT→RX

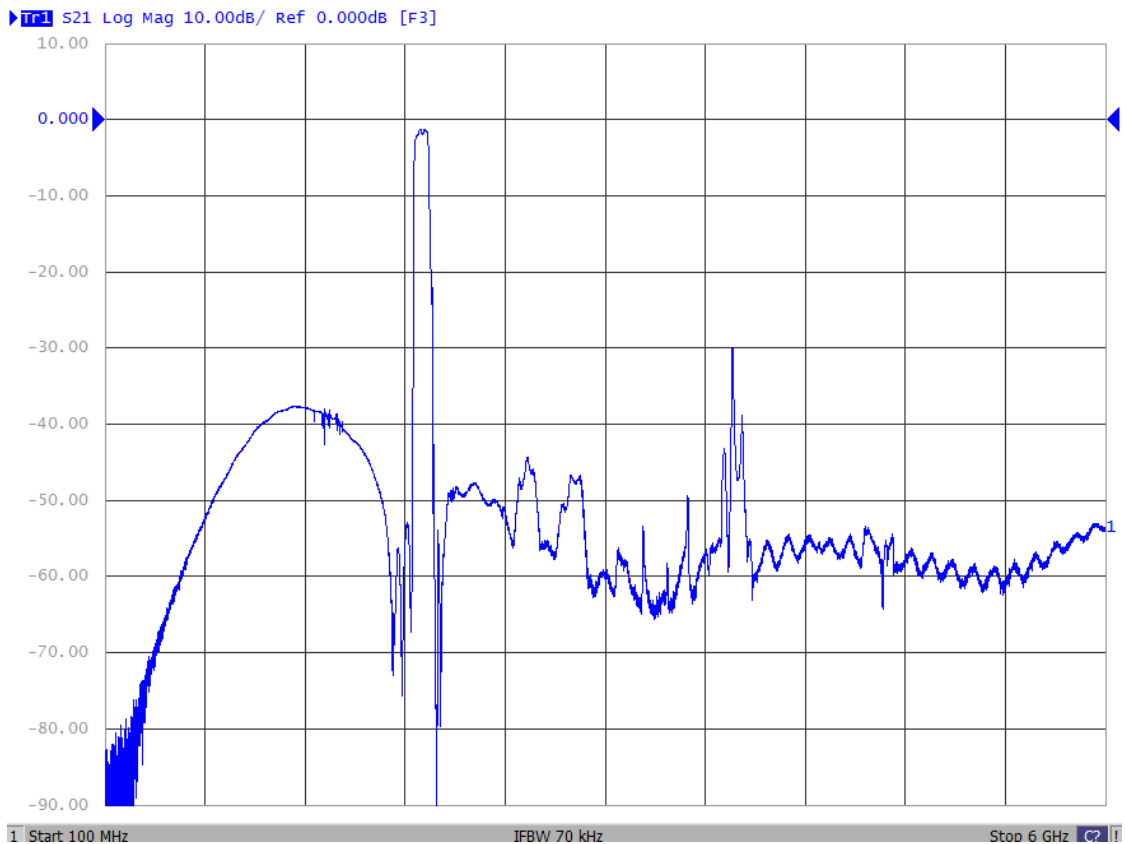

Figure 9: ANT→RX (Wide Band)

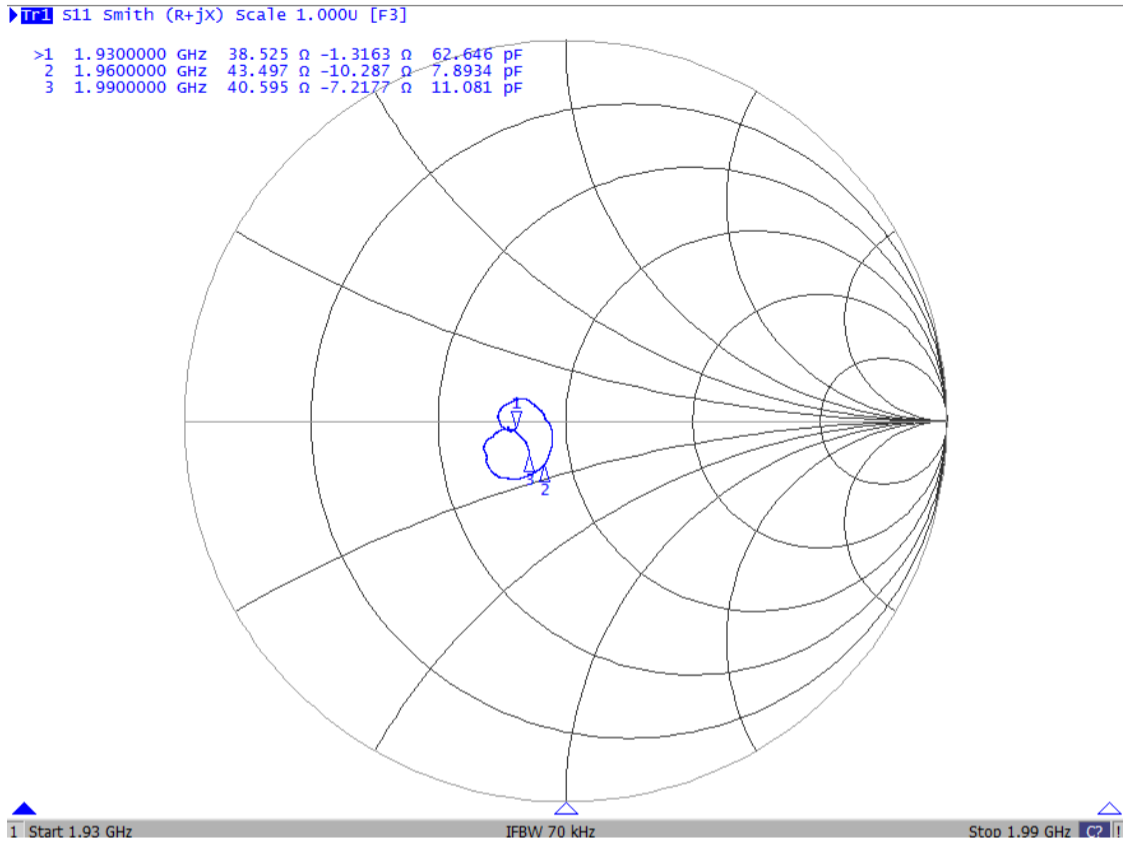

Figure 10: Smith for ANT

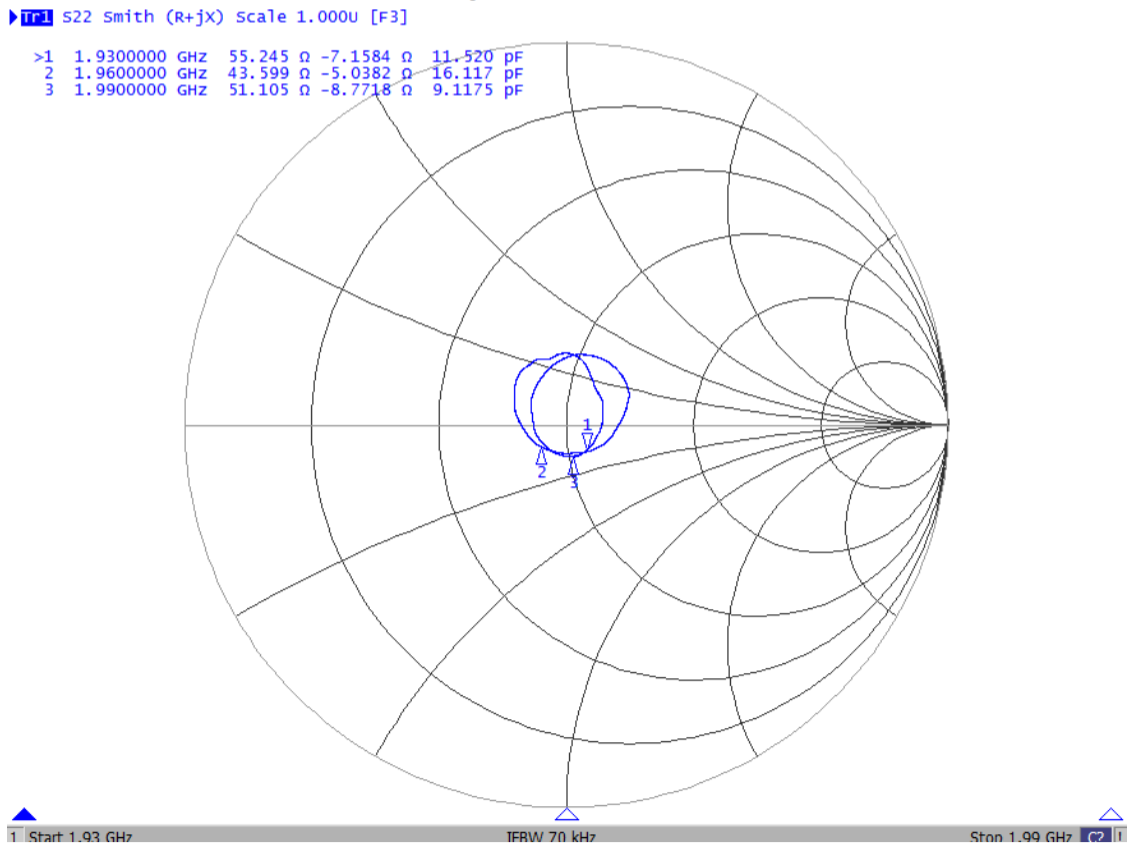

Figure 11: Smith for RX

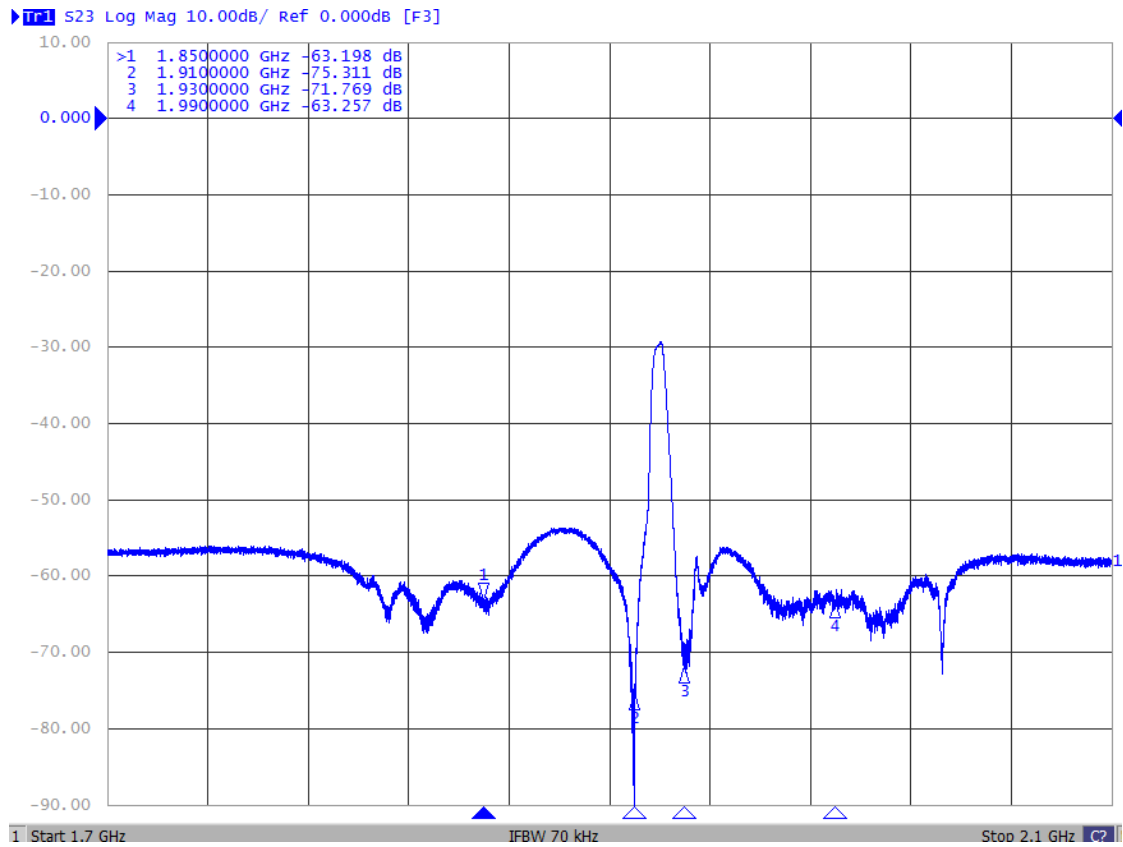

Figure 12: TX→RX

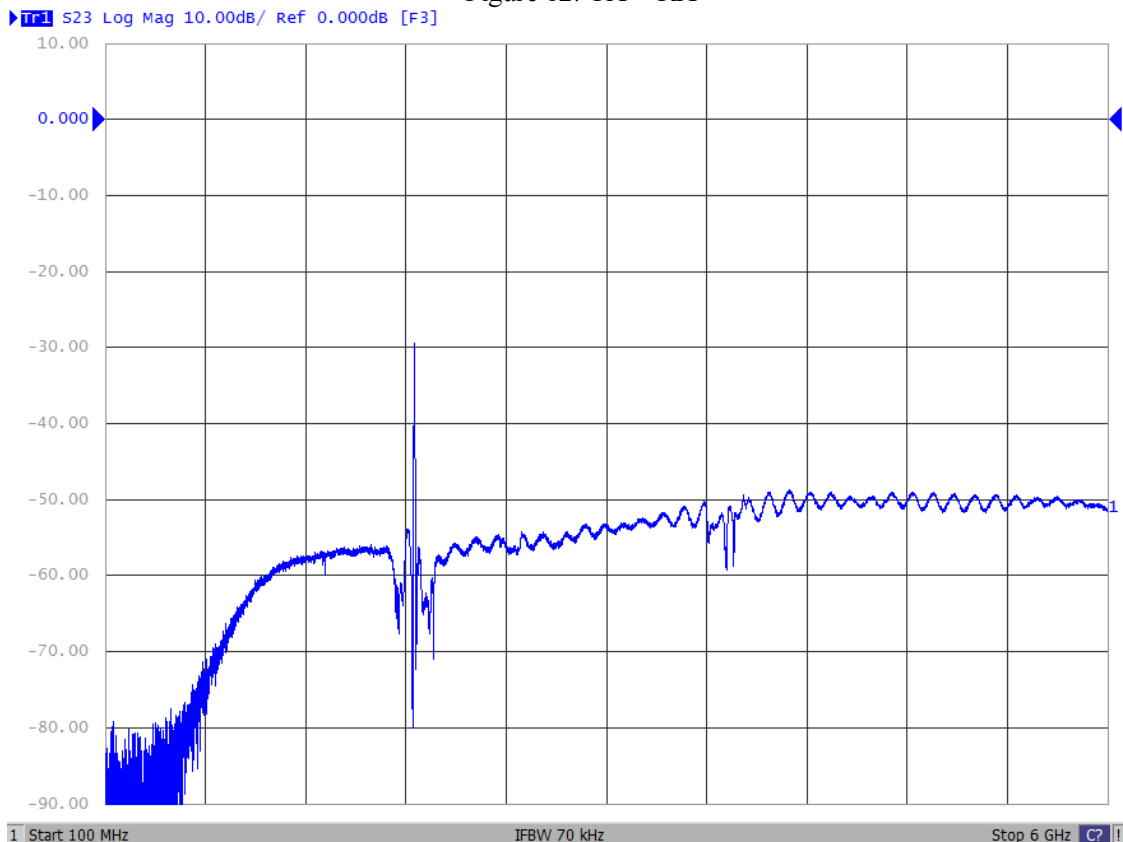

Figure 13: TX→RX (Wide Band)

9 Packaging

9.1 Tape

Tensile Strength of Carrier Tape: Carrier tape 10N or more; Cover tape 5N or more. Packaging quantities: 5000 PCS / Reel.

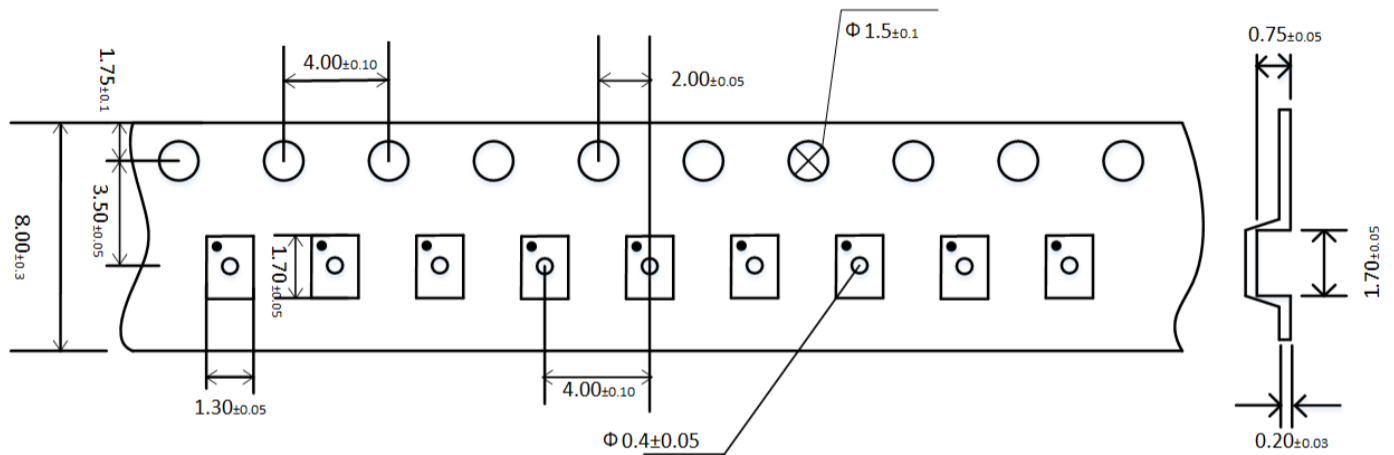

Figure 14: Drawing of tape with tape dimensions according above (mm).

9.2 Reel with diameter of 178mm

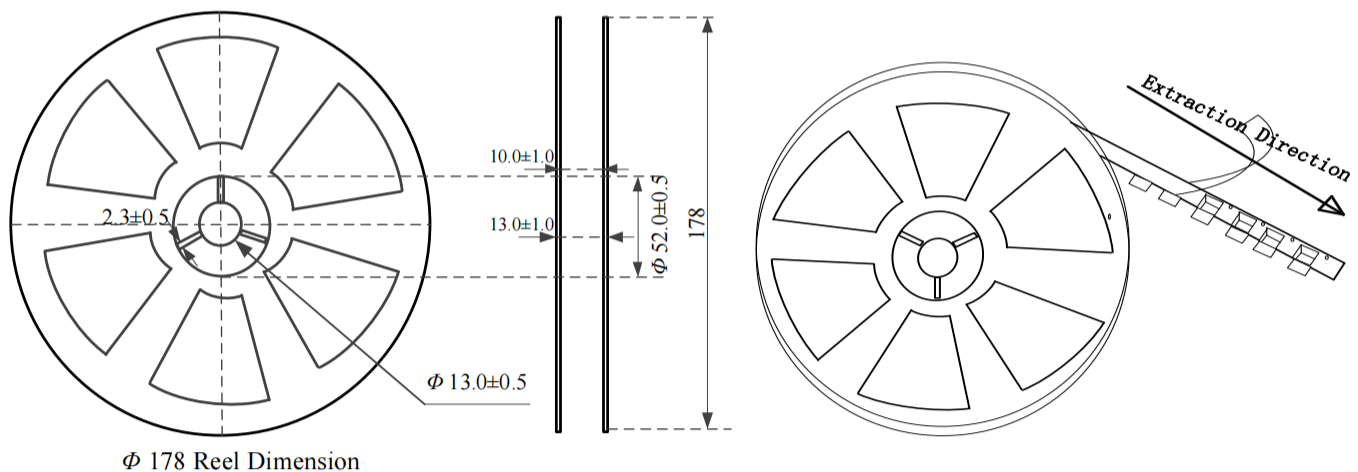

Figure 15: Drawing of reel with diameter of 178mm.

X-ON Electronics

Largest Supplier of Electrical and Electronic Components

Click to view similar products for [Signal Conditioning](#) category:

Click to view products by [Sunltech](#) manufacturer:

Other Similar products are found below :

[PD0409J5050S2HF](#) [HHS-109-PIN](#) [AFS14A35-1591.50-T3](#) [JP510S](#) [LFB322G45SN1A504](#) [SF2159E](#) [FM-104-PIN](#) [CER0813B](#)

[MAPDCC0005](#) [3A325](#) [BD0810N50100AHF](#) [DC0710J5005AHF](#) [DC2327J5005AHF](#) [LFL15869MTC1B787](#) [X3C19F1-20S](#)

[CDBLB455KCAX39-B0](#) [RF1353C](#) [051157-0000](#) [PD0922J5050D2HF](#) [600S150FTRB](#) [1E1305-3](#) [1F1304-3S](#) [TP-103-PIN](#)

[BD1222J50200AHF](#) [BD1722J50100AHF](#) [2450DP39K5400E](#) [BD0810J50150AHF](#) [BD1722J50200AHF](#) [DS-327-PIN](#) [MACP-008125-](#)

[CK07F0](#) [DS-329-PIN](#) [DS-313-PIN](#) [TP-104-PIN](#) [TP-101-PIN](#) [HH-128-PIN](#) [8594810000](#) [T-1000-N](#) [JP506S](#) [XC0900P-10S](#) [XC0900B-30S](#)

[CHE1260-QAG](#) [11305-10](#) [5962-9091202MXA](#) [3A412S](#) [X3C06A4-03S](#) [B39000Z3410A4](#) [DSS-333-PIN](#) [PD2425J5050S2HF](#)

[B39242B4360P810](#) [B39781B8005P810](#)