

Wire Wound Chip Inductor

1. SHAPES AND DIMENSIONS

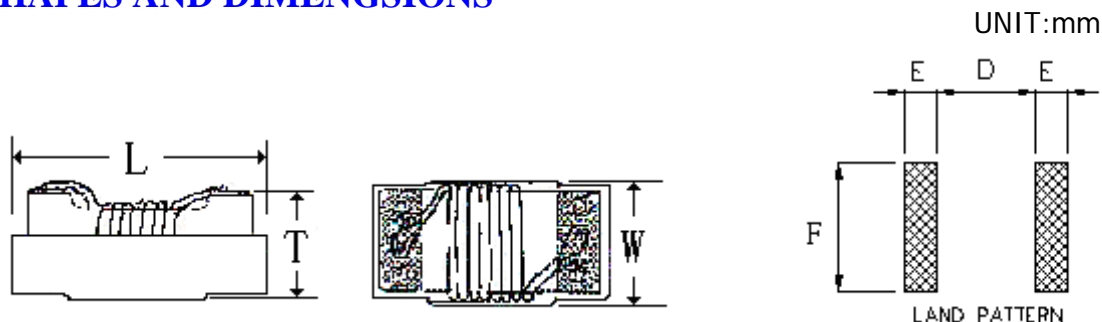

CODE		L(Max)	W(Max)	T(Max)	E(Typ.)	F(Typ.)	D(Typ.)
DIMENSION	1005(0402)	1.19	0.66	0.64	0.40	0.64	0.64
	1608(0603)	1.80	1.25	1.20	0.64	1.02	0.64
	2012(0805)	2.29	1.73	1.52	1.02	1.78	0.76
	2520(1008)	2.92	2.70	2.23	1.02	2.54	1.27
	3225(1210)	3.50	2.90	2.25	1.02	2.54	1.78
	4532(1812)	4.80	3.40	3.15	1.14	3.05	3.00

2. PART NUMBERING SYSTEM

SCW 2012 F R47 J S T HF
 1 2 3 4 5 6 7 8

- 1 PRODUCT SYMBOL (产品代号)
- 2 DIMENSIONS (规格尺寸)
- 3 MATERIAL (芯片类型)
- 4 INDUCTANCE (电感量)
- 5 TOLERANCE (公差) : F±1%; G±2%; J±5%; K±10%; M±20%
- 6 TERMINAL (端电极材料) : G-金端头; S-锡端头; Y-银钯端头
- 7 PACKAGING (包装方式) : T-编带盘装; B-散装
- 8 PHOSPHATE FREE (无红磷)

3. ELECTRICAL CHARACTERISTICS @25

No.	Part Number	L	Freq	Tolerance	Q	SRF	Rdc	Idc
		(uH)	(MHz)		(min)	(MHz)min	(Ω)max	(mA)max
1	SCW2012FR47*ST	0.47	7.9	J,K	12	500	0.31	720
2	SCW2012F1R0*ST	1.0	7.9	J,K	12	360	1.00	430
3	SCW2012F1R2*ST	1.2	7.9	J,K	12	350	1.15	410
4	SCW2012F1R5*ST	1.5	7.9	J,K	20	330	0.83	700
5	SCW2012F2R2*ST	2.2	7.9	J,K	12	170	1.50	350
6	SCW2012F3R3*ST	3.3	7.9	J,K	12	90	1.80	300
7	SCW2012F4R7*ST	4.7	7.9	J,K	12	85	2.05	250
8	SCW2012F6R8*ST	6.8	8.9	J,K	12	55	2.60	220
9	SCW2012F8R2*ST	8.2	9.9	J,K	12	50	3.00	180
10	SCW2012F100*ST	10	10.9	J,K	10	30	3.20	150
11	SCW2012F150*ST	15	11.9	J,K	10	16	4.20	100
12	SCW2012F220*ST	22	12.9	J,K	10	14	6.00	80
13	SCW2012F330*ST	33	13.9	J,K	10	17	10.70	60
14	SCW2012F680*ST	68	14.9	J,K	8	11	17.50	40

4. Recommended Soldering Conditions

Figure 1.
Re-flow
Soldering (Lead
Free)

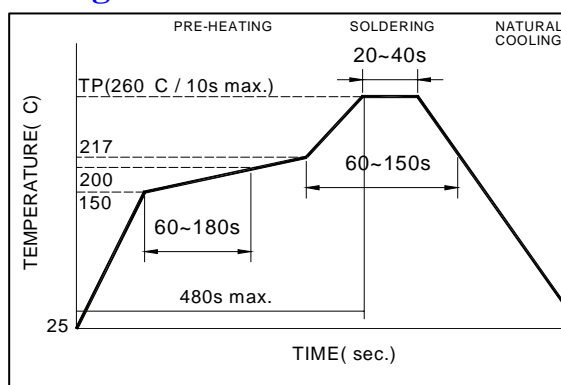

Note:

- Preheat circuit and products to 150°C
- 280°C tip temperature (max)

**Figure 2.
Wave Soldering**

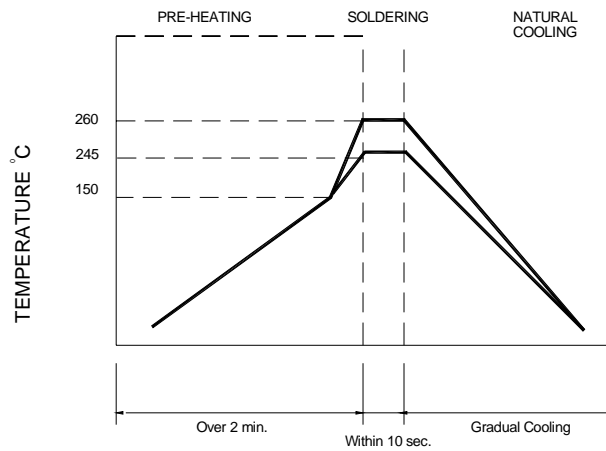

Note :

- Never contact the ceramic with the iron tip
- 1.0mm tip diameter (max)

**Figure 3.
Hand Soldering**

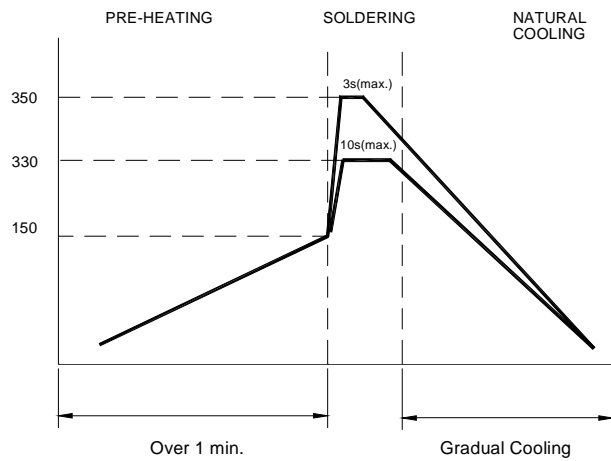

Note:

- Use a 20 watt soldering iron with tip diameter of 1.0mm
- Limit soldering time to 3 sec.

5. PACKAGING(unit: mm)

Tape

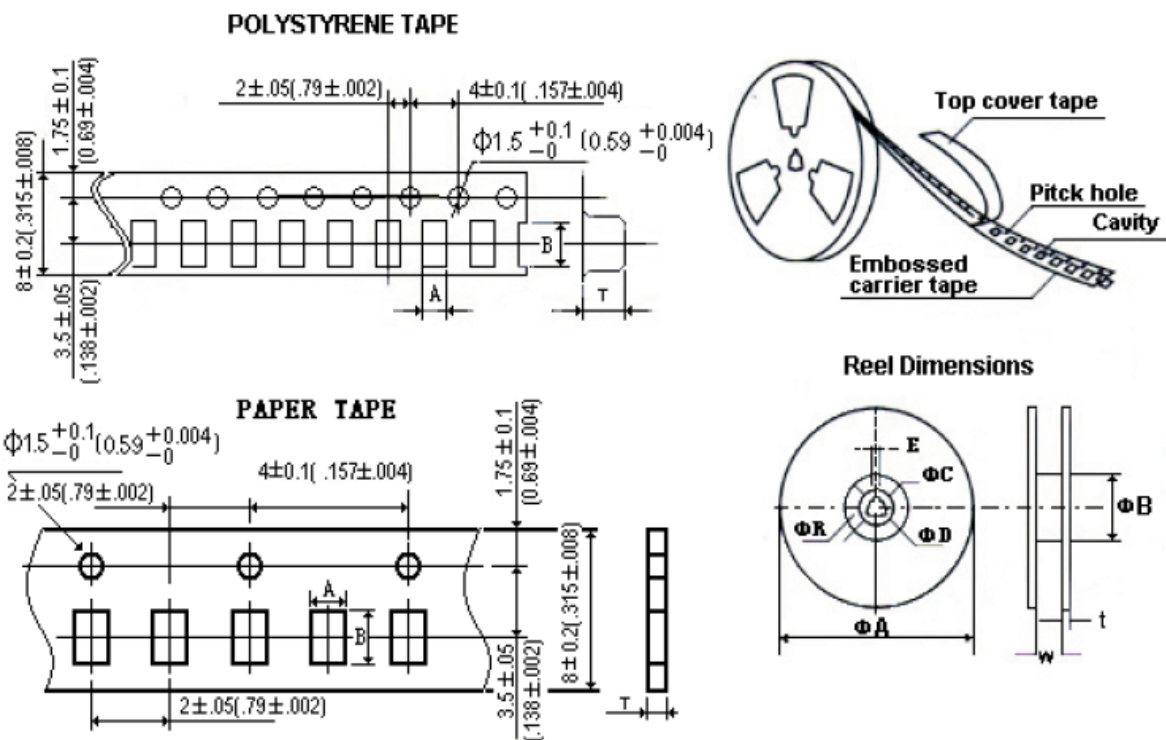

		A	B	T
纸带	0402	0.74	1.23	0.60
胶带	0603	1.15	1.83	0.95
	0805	1.85	2.40	1.45
	1008	2.73	2.90	2.34
	1210	2.96	3.60	2.40
	1812	3.22	4.82	3.15

unit:(mm)

unit	ΦA	ΦB	ΦC	ΦD	E	W	t	R
mm	178	60	13	21	2	10	2	1
	330	75	13	23	2	12	2	1

包装数量

Packaging Quantity

规格 Dimension	0402	0603	0805	1008	1210	1812
数量 Quantity(pcs)	10000	4000	3000	2000	2000	2000

6. 1 RELIABILITY TEST

TEST ITEM	SPECIFICATION		TEST CONDITION
	0402UC、0603UC、 0805UC、1008UC、 1210UC	0402IF、0805IF 、1210IF、 1812IF	
Operating Temperature Range	- 40 ~ +125°C	- 40 ~ +85°C	
Storage Temperature Range	- 40 ~ +125°C	- 40 ~ +85°C	
Rating current	150~1360mA(max)	40~1000mA (max)	Current sources:33010D
Inductance	1.0~8600uH	1.0~1000uH	Test Frequency:0.252~250MHz Test Equipment:HP4291A、HP4286A、HP4287A、 HP4284A Test Fixture:16193Aor16334A
Q	16~65(min)	10~35(min)	Test Frequency:0.252~1500MHz Test Equipment:HP4291A、HP4286A、HP4287A、 Test Fixture:16193Aor16334A
RDC	0.030~9.00Ω(max)	0.20~21.00Ω (max)	Test Equipment:HP4263B
SRF	55~12500MHz(min)	1.6~350MHz (min)	Test Equipment:HP4291A Test Fixture:16193A
Solderability	The metalized area must have more then 90%of solder coverage		Soldering Temp:230±5°C Dippng time:5±1S
Resistance to soldering heat	No eviden ce of mechanical damage The mealized arer must have more then 75%of solder coverage Inductance change,less than±5% Q chanqe less than±10%		Soldering Temp:260±5°C Dippng time:10±1S
Tehermal Shock	No eviden ce of mechanical damage Inductance change,less than±5% Q chanqe less than±10%		A cycle contain:Step1:-40°C , 30Min Step2:-85°C , 30Min Cycle Times:10

6.2 RELIABILITY TEST

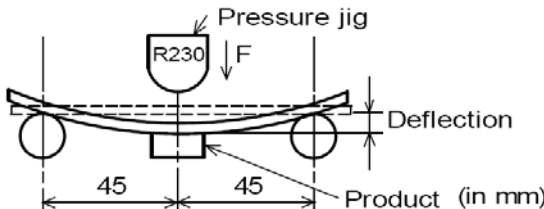
High Temperature Storage	No evidence of mechanical damage Inductance change, less than $\pm 5\%$ Q change less than $\pm 10\%$	Test Temperature: $125 \pm 2^\circ\text{C}$ (Ceramic core) $85 \pm 2^\circ\text{C}$ (Ferrite core) Test Time: 96 ± 2 Hours
Low Temperature Storage	No evidence of mechanical damage Inductance change, less than $\pm 5\%$ Q change less than $\pm 10\%$	Test Temperature: $-40 \pm 2^\circ\text{C}$ Test Time: 96 ± 2 Hours
Moisture Resistance	No evidence of mechanical damage Inductance change, less than $\pm 5\%$ Q change less than $\pm 10\%$	Test Temperature: $50 \pm 2^\circ\text{C}$ Test Time: 100 Hours 相对湿度 90~95%
Vibration	No evidence of mechanical damage Inductance change, less than $\pm 5\%$ Q change less than $\pm 10\%$	Amplitude: 1.5mm X、Y、Z方向各 1Hours45min Frequency range: 10~55~10Hz(min)
Component Adhesion	No evidence of mechanical damage No evidence of peel off or broken Keep continuity of Winding	Force: 2Kgf Test Time: 5 ± 1 秒
Resistance to bend	No evidence of mechanical damage	Camber: 20mm Test Board: Glass-Epoxy board Thickness: 8mm 
Life	No evidence of mechanical damage Inductance change, less than $\pm 5\%$ Q change less than $\pm 10\%$	Test Temperature: $85 \pm 2^\circ\text{C}$ Test Time: 1000 Hours with rating current Test Time: 96 ± 2 Hours

X-ON Electronics

Largest Supplier of Electrical and Electronic Components

Click to view similar products for [Fixed Inductors](#) category:

Click to view products by [Sunltech](#) manufacturer:

Other Similar products are found below :

[CR32NP-151KC](#) [CR32NP-180KC](#) [CR32NP-181KC](#) [CR32NP-1R5MC](#) [CR32NP-390KC](#) [CR32NP-3R9MC](#) [CR32NP-680KC](#) [CR32NP-820KC](#) [CR32NP-8R2MC](#) [CR43NP-390KC](#) [CR43NP-560KC](#) [CR43NP-680KC](#) [CR54NP-181KC](#) [CR54NP-470LC](#) [CR54NP-820KC](#) [CR54NP-8R5MC](#) [70F224AI](#) [MGDQ4-00004-P](#) [MHL1ECTTP18NJ](#) [MHQ1005P10NJ](#) [MHQ1005P1N0S](#) [MHQ1005P2N4S](#) [MHQ1005P3N6S](#) [MHQ1005P5N1S](#) [MHQ1005P8N2J](#) [PE-51506NL](#) [PE-53601NL](#) [PE-53602NL](#) [PE-53630NL](#) [PE-53824SNLT](#) [PE-92100NL](#) [PG0434.801NLT](#) [PG0936.113NLT](#) [9220-20](#) [9310-16](#) [PM06-2N7](#) [PM06-39NJ](#) [A01TK](#) [1206CS-471XJ](#) [HC2LP-R47-R](#) [HC2-R47-R](#) [HC3-2R2-R](#) [HCF1305-3R3-R](#) [1206CS-151XG](#) [RCH664NP-140L](#) [RCH664NP-4R7M](#) [RCH8011NP-221L](#) [RCP1317NP-332L](#) [RCP1317NP-391L](#) [RCR1010NP-470M](#)