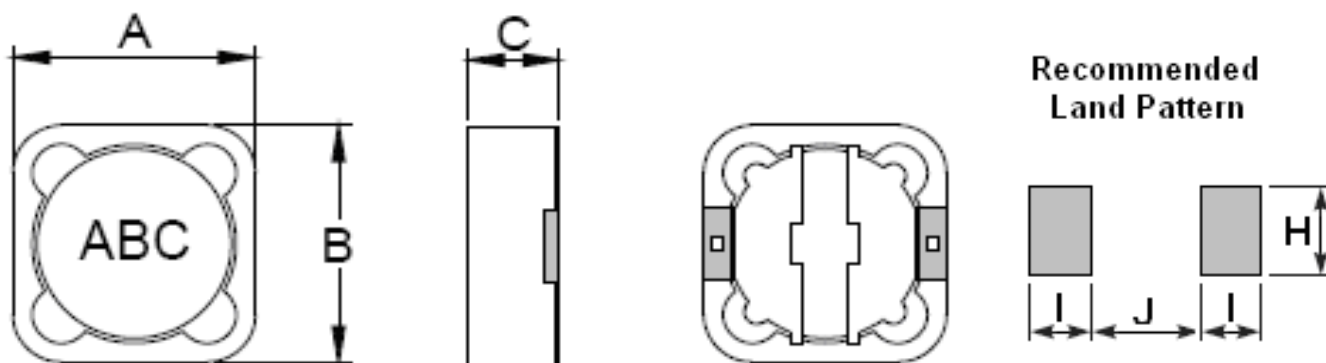
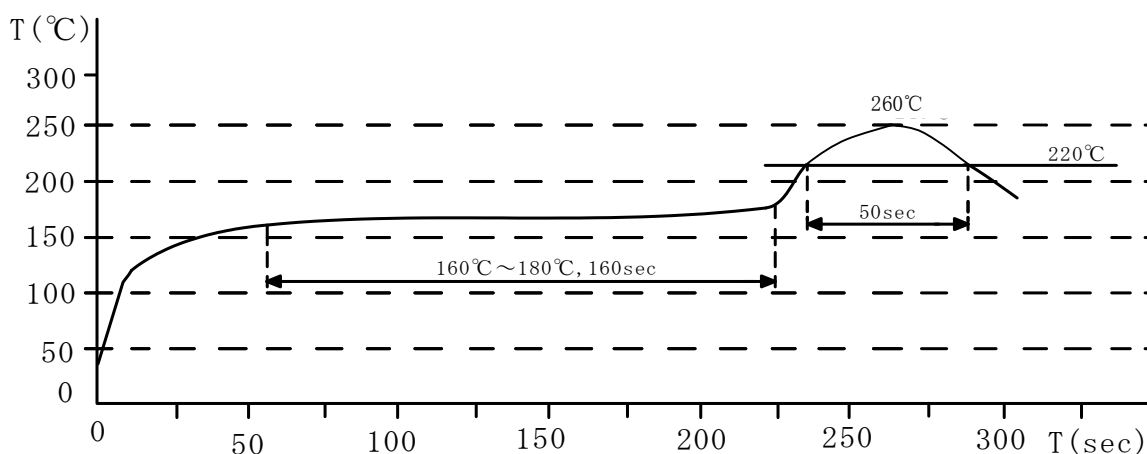

Shielded High Current SMD Power Inductor
◆ Dimensions(Unit:mm):

Series	A	B	C	I	J	H
SLH1209S Series	12.5 Max	12.5 Max	10.0Max	2.2Typ	7.4Typ	4.9Typ

◆ Recommended Reflow Condition

Reflow soldering time: 6min

We recommend infrared ray heat source of reflow bath.

However halogen lamp shall be used side heat will be beyond range of resistance heat,so we can't recommend it

◆ Specifications

Part No.	Test Frequency	Indutance (uH)	DC (Ω) MAX	Isat(A) MAX	Irms(A) MAX
SLH1209S1R0NST	100KHz/0.3V	1.0	0.015	20.0	10.0
SLH1209S2R2NST	100KHz/0.3V	2.2	0.018	17.0	9.0
SLH1209S3R3NST	100KHz/0.3V	3.3	0.020	14.0	8.0
SLH1209S4R7NST	100KHz/0.3V	4.7	0.022	11.0	8.0
SLH1209S6R8NST	100KHz/0.3V	6.8	0.025	10.0	7.0
SLH1209S100MST	100KHz/0.3V	10.0	0.027	9.0	6.0
SLH1209S150MST	100KHz/0.3V	15.0	0.030	8.0	5.5
SLH1209S220MST	100KHz/0.3V	22.0	0.050	6.5	5.0
SLH1209S330MST	100KHz/0.3V	33.0	0.060	5.0	4.5
SLH1209S470MST	100KHz/0.3V	47.0	0.080	4.4	4.0
SLH1209S560MST	100KHz/0.3V	56.0	0.090	3.8	3.5
SLH1209S680MST	100KHz/0.3V	68.0	0.100	3.6	3.0
SLH1209S101MST	100KHz/0.3V	100	0.140	3.0	2.5
SLH1209S121MST	100KHz/0.3V	120	0.170	2.5	2.2
SLH1209S151MST	100KHz/0.3V	150	0.230	2.0	1.8
SLH1209S221MST	100KHz/0.3V	220	0.280	1.8	1.6
SLH1209S331MST	100KHz/0.3V	330	0.540	1.5	1.4
SLH1209S471MST	100KHz/0.3V	470	0.610	1.2	1.1
SLH1209S681MST	100KHz/0.3V	680	0.980	1.0	0.9
SLH1209S102MST	100KHz/0.3V	1000	1.200	0.7	0.5
SLH1209S122MST	100KHz/0.3V	1200	1.500	0.6	0.4
SLH1209S222MST	100KHz/0.3V	2200	3.200	0.4	0.3

◆ Reliability Testing Items

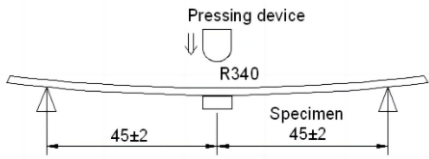
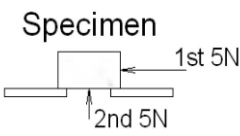
Item	Specification	Condition
Bending Test	Change from an initial value L: within±10%	Apply pressure gradually in the direction of the arrow at a rate of about 0.5mm/s until bent depth reaches 3mm and hold for 30±5s  Board: 40X100mm Thickness: 1.0mm
Adhesion strength	Change from an initial value L: within±10%	A static load using a R0.5 pressing tool shall be applied the arrow and to the body of the specimen in the direction of the arrow and shall be hold for 60±5s.Measure after removing pressure. 
Vibration	Change from an initial value L : within±10%	The specimen shall be subjected to a vibration of 1.5mm amplitude, sweep frequency 10~55Hz (10Hz to 55Hz to 10Hz in a period of one minute) for 1 h in each of 3(X,Y,Z) axes.
Mechanical shock	Change from an initial value L : within±10%	Peak acceleration: 981 m/S ² Duration of pulse: 6ms 3 times in each of 3(X,Y,Z)axes. The specimen must be fixed on test board. Three successive shock shall be applied in the perpendicular direction of each surface of the specimen.
Free fall test	Change from an initial value L : within±10%	The specimen must be fixed on test board. It must be equipped with instruments of which weight is 500g. Then it shall be fallen freely from 1m height to rigid wood 3 times in each of three axes
Solder ability	New solder shall cover 90% minimum of the surface immersed	Terminals shall be immersed for 5 to 10 seconds in flux at room temperature. Dip sample into solder bath containing molten solder at 245±5°C for 3±0.5 seconds.

Item	Specification	Condition
Resistance to soldering heat	Change from an initial value L : within±10%	Test method : Reflow soldering method Preheat:150~180°C 90±30s Peak temp:250(+ 5,-0)°C (230°C min , 30±10s) The specimen shall be subjected to the reflow process under the above condition 2 times. Test board shall be 0.8mm thick. Base material shall be glass epoxy resin Measurement The specimen shall be stored at standard atmospheric conditions for 1 h in prior to the measurement.
Dielectric strength	Without damage	100V DC shall be applied for 60s between the terminal and the core
Insulation resistance	100mΩ or more.	100V DC shall be applied between the terminal and the core
Low temperature	Change from an initial value L : within±10%	The specimen shall be stored at a temperature of -40±3°C for 500 ±12h. Then it shall be stabilized under standard atmospheric conditions for 1 h before measurement Measurement shall be made within 1h.
Dry heat	Change from an initial value L : within±10%	The specimen shall be stored at a temperature of 125±2°C for 500± 12h. Then it shall be stabilized under standard atmospheric conditions for 1 h before measurement. Measurement shall be made within 1h
Dump heat	Change from an initial value L : within±10%	The specimen shall be stored at a temperature of 125±2°C with relative humidity of 90 ~ 95% for 500±2h. Then it shall be stabilized under standard atmospheric conditions for 1 h before measurement. Measurement shall be made within 1h

Item	Specification	Condition
Temperature cycle	Change from an initial value L : within $\pm 10\%$	The specimen shall be subjected to 500 continuous cycles of temperature change of -40°C for 30 min and 85°C for 30 min with the transit period of 2min or less. Then it shall be stabilized under standard atmospheric conditions for 1 h before measurement. Measurement shall be made within 1h
Temperature drift	Inductance temperature coefficient 2000 ppm/ $^{\circ}\text{C}$ or less	To be measured in the range of -40°C to 125°C .
Operating temperature range	$-40 \sim + 125^{\circ}\text{C}$	Including self temperature rise.
Storage temperature range	$-40 \sim + 125^{\circ}\text{C}$	With taping.

◆ Standard atmospheric conditions

Unless otherwise specified, the standard range of atmospheric conditions in making measurements and test as follows;

Ambient temperature : 5°C to 35°C , Relative humidity: 45% to 85%, Air pressure: 86kPa to 106kPa

If more strict measurement is required, measurement shall be made within following limits;

Ambient temperature : $20 \pm 2^{\circ}\text{C}$, Relative humidity: $65 \pm 5\%$, Air pressure: 86kPa to 106kPa

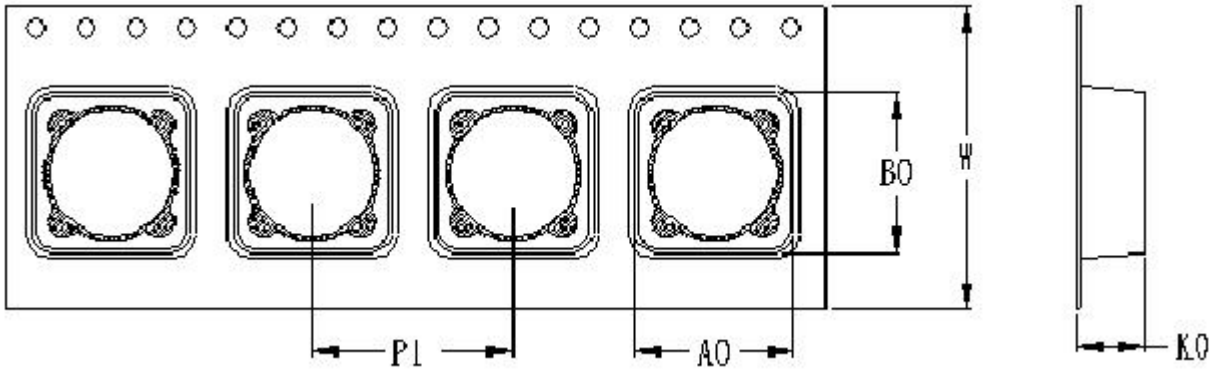
◆ Package
1:Tape Dimension:(unit:mm)

Part NO	P1	W	A0	B0	K0
SLH1209S Series	16.0±0.1	24.0±0.3	12.6±0.2	12.6±0.2	10.0±0.15

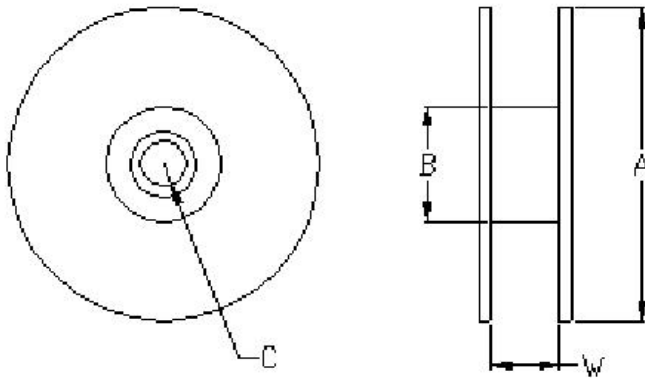
2:Dimension:(unit:mm)

Series	A	B	C	W	Reel
SLH1209S Series	330	100	13	24	400PCS

X-ON Electronics

Largest Supplier of Electrical and Electronic Components

Click to view similar products for [Fixed Inductors](#) category:

Click to view products by [Sunltech](#) manufacturer:

Other Similar products are found below :

[CR32NP-100KC](#) [70F224AI](#) [MHQ1005P10NJ](#) [MHQ1005P1N0S](#) [MHQ1005P2N4S](#) [MHQ1005P3N6S](#) [MHQ1005P5N1S](#) [MHQ1005P8N2J](#)
[PE-53601NL](#) [PE-53602NL](#) [PG0936.113NLT](#) [9220-20](#) [9310-16](#) [PM06-2N7](#) [PM06-39NJ](#) [A01TK](#) [1206CS-471XJ](#) [HC2-R47-R](#) [HC8-1R2-R](#)
[HCF1305-3R3-R](#) [1206CS-151XG](#) [RCH664NP-4R7M](#) [RCP1317NP-391L](#) [DH2280-4R7M](#) [DS1608C-106](#) [B10TJ](#) [B82498B3101J000](#) [ELJ-](#)
[RE27NJF2](#) [1812CS-153XJ](#) [1812CS-183XJ](#) [1812CS-223XJ](#) [1812LS-104XJ](#) [1812LS-105XJ](#) [1812LS-124XJ](#) [1812LS-154XJ](#) [1812LS-223XJ](#)
[1812LS-224XJ](#) [1812LS-563XJ](#) [1812LS-683XJ](#) [1812LS-824XJ](#) [NIN-FB101JTR110F](#) [NIN-FB471JTR62F](#) [NIN-FC1R5JTR220F](#) [NIN-](#)
[HCR15JTRF](#) [NIN-HCR33JTRF](#) [NIN-HDR22JTRF](#) [NIN-HDR82JTRF](#) [NIN-HK2N7STRF](#) [NIN-PA150KTR370F](#) [NIN-PB100KTR550F](#)