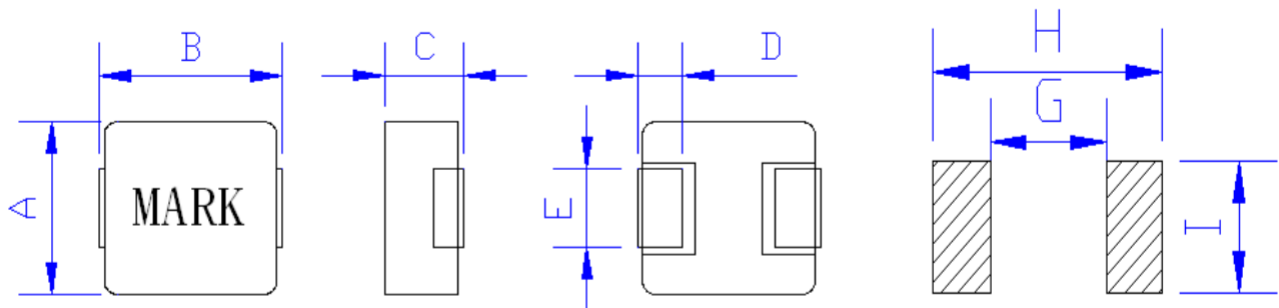
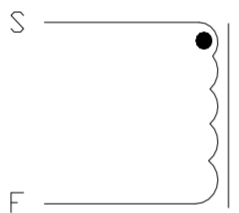

SMD Molding Power Inductor
◆ Dimensions(Unit:mm):

◆ Schematic Diagram:

A	8.00±0.3
B	8.70±0.5
C	5.0 MAX
D	1.80±0.3
E	3.00±0.3
G	4.50 Ref
H	9.00 Ref
I	3.50 Ref

◆ Electrical Characteristics:

Part NO.	Inductance (μH)	Accuracy Grade	Test Frequency (KHz)	Test Voltage (mV)	Rdc (mΩ)		Idc (A)		Isat (A)	
					Typ	Max	Max	Typ	Max	Typ
SLO0850HR15MTT	0.15	±20%	100	1000	0.6	0.7	38.0	40.0	58.0	60.0
SLO0850HR22MTT	0.22	±20%	100	1000	1.8	2.1	25.0	26.0	53.0	55.0
SLO0850HR47MTT	0.47	±20%	100	1000	2.5	2.9	22.0	23.0	28.0	30.0
SLO0850HR68MTT	0.68	±20%	100	1000	3.6	4.0	18.0	19.0	23.0	25.0
SLO0850HR82MTT	0.82	±20%	100	1000	4.0	4.8	17.0	18.0	23.0	24.0

Part NO.	Inductance (μH)	Accuracy Grade	Test Frequency (KHz)	Test Voltage (mV)	Rdc (mΩ)		Idc (A)		Isat (A)	
					Typ	Max	Max	Typ	Max	Typ
SLO0850H1R0MTT	1.0	±20%	100	1000	4.1	4.8	16.0	17.0	19.0	20.0
SLO0850H1R5MTT	1.5	±20%	100	1000	4.9	5.7	14.0	15.0	19.0	20.0
SLO0850H2R2MTT	2.2	±20%	100	1000	8.2	9.5	11.0	12.0	15.0	16.0
SLO0850H3R3MTT	3.3	±20%	100	1000	11.0	13.0	10.0	10.5	12.0	13.0
SLO0850H4R7MTT	4.7	±20%	100	1000	15.0	18.0	8.5	9.5	11.0	12.0
SLO0850H5R6MTT	5.6	±20%	100	1000	19.8	24.0	8.0	9.0	12.0	13.0
SLO0850H6R8MTT	6.8	±20%	100	1000	20.0	24.0	8.0	9.0	10.0	11.0
SLO0850H100MTT	10.0	±20%	100	1000	35.0	41.0	6.0	6.5	7.0	8.0
SLO0850H150MTT	15.0	±20%	100	1000	47.0	56.5	5.0	6.0	6.5	7.0
SLO0850H220MTT	22.0	±20%	100	1000	74.0	81.0	4.0	4.5	5.0	5.5
SLO0850H330MTT	33.0	±20%	100	1000	120.0	132.0	2.5	3.5	4.5	5.0
SLO0850H470MTT	47.0	±20%	100	1000	177.0	195.0	2.0	2.5	3.0	3.5
SLO0850H560MTT	56.0	±20%	100	1000	170.0	187.0	2.2	2.5	3.0	3.5
SLO0850H680MTT	68.0	±20%	100	1000	235.0	258.0	1.5	2.0	2.5	3.0
SLO0850H101MTT	100	±20%	100	1000	272.0	300.0	1.0	1.5	2.0	2.5

※

1: Test conditions: All tests were conducted at room temperature $25 \pm 2^\circ\text{C}$

2: Rated current: At room temperature 25°C , after loading the current, the surface temperature of the product rises by about 40°C (no more than 40°C)

3: Saturation current: At room temperature 25°C , after loading the current, the inductance value drops to 70% of the initial inductance value (no less than 70%).

4: Operating temperature range: $-40^\circ\text{C} \sim +125^\circ\text{C}$ (including product surface temperature rise).

In the extreme use environment, the highest temperature that the product can withstand (including product surface temperature rise) does not exceed 125°C . Circuit design, component placement, PCB size and thickness, heat dissipation device and operating frequency will affect the product temperature, please verify the actual temperature of the product in the application.

◆ Reliability Testing Items

Items	Specifications	Test Method/Condition
Electrical Performance Test		
L	Refer to standard electrical characteristic list.	Microtest 6377
Rdc	Refer to standard electrical characteristic list.	TH 2511
Idc	Refer to standard electrical characteristic list.	Applied the current to coils the inductance change should not be less than 30% to initial value and temperature rise should not be 40°C typical.
Temperature rise test	The temperature rise does not exceed 40°C.	Applied the rated current for 4 hours.
Overload test	No evidence of electrical damage	Applied 1.5 times of rated current for a period of 5 minutes
Climatic Test		
Operating temperature range	-45°C ~ +125°C	Includes product surface temperature rise
High temperature resistance	No mechanical damage. Inductance should not change more than ±10%	+125°C ± 2°C / 1000h Test at room temperature for 1 hour.
Low temperature resistance	No mechanical damage. Inductance should not change more than ±10%	-45°C ± 2°C / 1000h. Test at room temperature for 1 hour.
Temperature shock	No mechanical damage. Inductance should not change more than ±10%	Temperature: -45°C for 30 ± 3min +125°C for 30 ± 3min Number of cycles: 1000
Static humidity	No mechanical damage. Inductance should not change more than ±10%	Humidity: 85% RH Temperature: 85°C ± 2°C Testing time: 1000 ± 2h

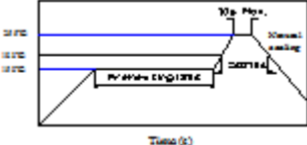
Item	Specifications	Test Method/Condition
Mechanical performance test		
Solder ability test	At least 95% of terminal electrode should be covered with solder.	Preheating temperature: 150°C Preheating time: 120s Solder temperature: 255 ± 5°C Duration: 10s Max 
Resistance to soldering	At least 95% of terminal electrode should be covered with solder. No mechanical damage. Inductance should not change more than ±10%	Repeat the reflow curve twice.
Vibration test	No mechanical damage. Inductance should not change more than ±10%	Amplitude modulation: 1.5mm Test time: A period of 2h in each of 3 mutually perpendicular directions. Frequency range: 10Hz to 55Hz to 10Hz for 1min
Shock test	No mechanical damage. Inductance should not change more than ±10%	Duration: 6ms Peak acceleration: 100g Direction: ±X ±Y ±Z (6 directions) Number of shocks: Three consecutive shocks in each direction (total 18 times)
Adhesion of electrode	No mechanical damage Inductance should not change more than ±10%	A 17.7N(1.8kg) force is applied to the side of the inductance for 60(±1)s
Circuit board bending test	No mechanical damage. Inductance should not change more than ±10%.	Apply a force to bend the circuit board at least (D)x=2mm, and the duration of the applied force should be 60(±5)s.

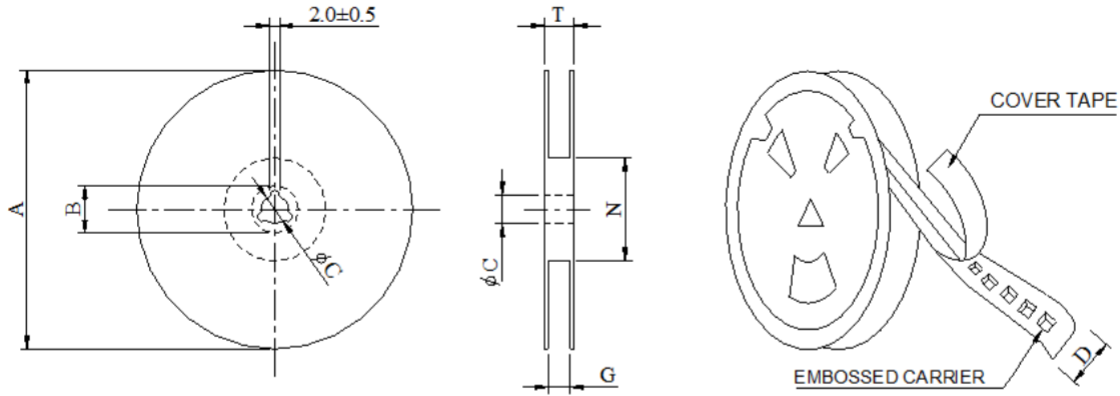
◆ PACKAGING:(Unit:mm)

Part NO.	A	B	C	D	G	N	T	Reel
SLO0850H Series	330	21	13	24	25	100	28	1000Pcs

X-ON Electronics

Largest Supplier of Electrical and Electronic Components

Click to view similar products for [Fixed Inductors](#) category:

Click to view products by [Sunltech](#) manufacturer:

Other Similar products are found below :

[CR32NP-100KC](#) [70F224AI](#) [MHQ1005P10NJ](#) [MHQ1005P1N0S](#) [MHQ1005P2N4S](#) [MHQ1005P3N6S](#) [MHQ1005P5N1S](#) [MHQ1005P8N2J](#)
[PE-53601NL](#) [PE-53602NL](#) [PG0936.113NLT](#) [9220-20](#) [9310-16](#) [PM06-2N7](#) [PM06-39NJ](#) [A01TK](#) [1206CS-471XJ](#) [HC2-R47-R](#) [HC8-1R2-R](#)
[HCF1305-3R3-R](#) [1206CS-151XG](#) [RCH664NP-4R7M](#) [RCP1317NP-391L](#) [DH2280-4R7M](#) [DS1608C-106](#) [B10TJ](#) [B82498B3101J000](#) [ELJ-](#)
[RE27NJF2](#) [1812CS-153XJ](#) [1812CS-183XJ](#) [1812CS-223XJ](#) [1812LS-104XJ](#) [1812LS-105XJ](#) [1812LS-124XJ](#) [1812LS-154XJ](#) [1812LS-223XJ](#)
[1812LS-224XJ](#) [1812LS-563XJ](#) [1812LS-683XJ](#) [1812LS-824XJ](#) [NIN-FB101JTR110F](#) [NIN-FB471JTR62F](#) [NIN-FC1R5JTR220F](#) [NIN-](#)
[HCR15JTRF](#) [NIN-HCR33JTRF](#) [NIN-HDR22JTRF](#) [NIN-HDR82JTRF](#) [NIN-HK2N7STRF](#) [NIN-PA150KTR370F](#) [NIN-PB100KTR550F](#)