

SMD Molding Power Inductor

◆ Features

- 1、Soft saturation
- 2、High current, low DCR, high efficiency
- 3、High reliability.
- 4、100% Lead(Pb)-Free and RoHS compliant.
- 5、Operating temperature -55~+125°C
(Including self - temperature rise)

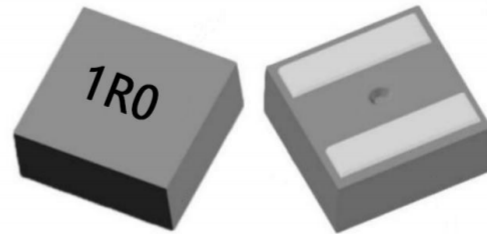

◆ Applications

- 1、Note PC power system, incl. IMVP-6
- 2、DC/DC converter
- 3、Pad,Smart phone.
- 4、Portable gaming devices, Smart wear, Wi-Fi module.
- 5、Notebooks, VR, AR
- 6、LCD displays, HDDs, DVCs, DSCs, etc
- 7、Baseband power supply, Amplifier, Power management,
Module power supply, Camera power manageme.

◆ Lead Free Part Numbering

SLO 1513 T 1R0 M S T
(1) (2) (3) (4) (5) (6) (7)

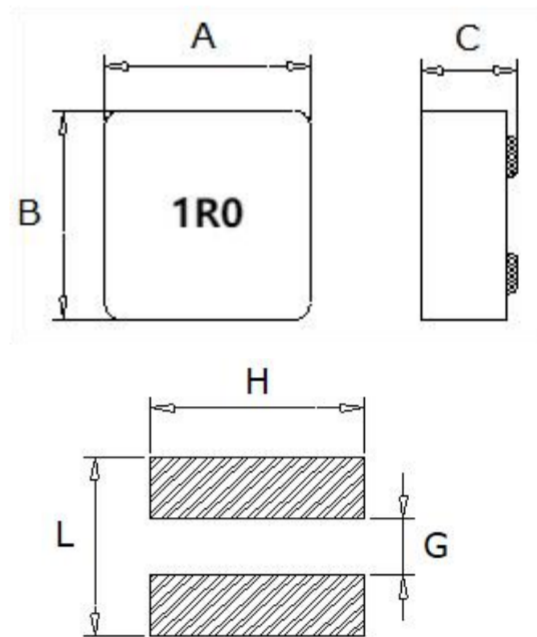
- (1) Series Type
- (2) Dimension: A X C
- (3) Material Code
- (4) Inductance: 1R0=1.0μH ;
2R2=2.2μH;
- (5) Inductance Tolerance: M=±20%, Y=±30%
- (6) Company Code
- (7) Packaging : packed in embossed carrier tape

◆ Dimensions

Series	A±0.3(mm)	B±0.3mm)	C±0.3(mm)	L Ref(mm)	H Ref(mm)	G Ref(mm)
SLO1513T	16.5	15.5	12.7	15.0	15.0	6.0

◆ Specification

Part Number	INDUCTANCE Lo(μ H)	DCR (m Ω)	Test a condition	Isat (A)		Irms (A)Typ	
		Max.		Max.	Typ	20 $^{\circ}$ C rise	40 $^{\circ}$ C rise
SLO1513T Series							
SLO1513T4R7MTT	4.7	3.3	100KHz/0.1V	40.0	44.0	23.0	31.0
SLO1513T5R6MTT	5.6	3.9	100KHz/0.1V	35.0	40.0	22.0	29.0
SLO1513T6R8MTT	6.8	4.2	100KHz/0.1V	32.0	37.0	21.0	27.0
SLO1513T8R2MTT	8.2	5.74	100KHz/0.1V	29.0	33.0	20.0	26.0
SLO1513T100MTT	10	7.0	100KHz/0.1V	27.0	30.0	19.0	25.0
SLO1513T150MTT	15	7.5	100KHz/0.1V	21.0	25.5	16.0	22.0
SLO1513T220MTT	22	13.86	100KHz/0.1V	19.0	22.0	12.0	17.0
SLO1513T330MTT	33	22.2	100KHz/0.1V	16.0	19.0	9.0	14.0

NOTES:

1. Test frequency : L : 100KHz /0.1V;
2. All test in 25 $^{\circ}$ C temperature.
3. Testing Instrument:L:HP4285A,CH11025,CH3302,CH1320,CH1320S LCR METER / Rdc:CH16502, MICRO OHMMETER.
4. Heating Rating Current (Irms) will cause the coil temperature rise of 40 $^{\circ}$ C approximately (Δ t) ;
5. Saturation Current (Isat) will cause L0 to drop 30% approximately.
6. The part temperature (ambient + temp rise) should not exceed 125 $^{\circ}$ C under the worst case operating condition. Circuit design, component,PCB trace size and thickness airflow and other cooling provisions all could affect the part temperature. Part temperature should be verified in the end application.
7. Special inquiries besides the above common used types can be met on your requirement.n.



DCR Test

◆ Reliability Test

Mechanical Reliability		
Item	Specification and Requirement	Test Method
Solderability	1. No case deformation or change in visual 2. New solder coverage More than 95%	1.Preheat: $155^{\circ}\text{C} \pm 5^{\circ}\text{C}$, $60\text{S} \pm 2\text{S}$ 2.Tin: lead-free. 3.Temperature: $240^{\circ}\text{C} \pm 5^{\circ}\text{C}$, flux $3.0\text{S} \pm 0.5\text{S}$.
Mechanical shock	1. No case deformation or change in visual 2. $\Delta\text{L}/\text{Lo} \leq \pm 10\%$	1. Acceleration: 100G 2. Pulse time: 6ms 3. 3 times in each positive and negative direction of 3 mutual perpendicular directions
Mechanical vibration	1. No case deformation or change in visual 2. $\Delta\text{L}/\text{Lo} \leq \pm 10\%$	1. Reflow: 2times 2. Frequency: $10\text{HZ} \sim 50\text{HZ} \sim 10\text{HZ}$, 20 Min/Cycles 3. Amplitude: $1.52 \text{ mm} \pm 10\%$ 4. Directions: X,Y,Z 5. Time: 12 cycle / direction
Endurance Reliability		
Item	Specification and Requirement	Test Method
Thermal Shock	Inductance change: Within $\pm 10\%$ Without distinct damage in visual	1. First -55°C for 30 minutes, last 125°C for 30 minutes as 1 cycle. Go through 1000 cycles. 2. Max transfer time is 3 minutes. 3. Measured at room temperature after placing for 24 ± 2 hours
Humidity Resistance	Inductance change: Within $\pm 10\%$ Without distinct damage in visual	1.Reflow 2 times, 2. $85^{\circ}\text{C} \pm 3^{\circ}\text{C}$, $85\% \pm 3\% \text{RH}$, 1000 hours 3.Measured at room temperature after placing for 24 ± 2 hours
Low temperature storage	Inductance change: Within $\pm 10\%$ Without distinct damage in visual	1. Temperature: $-55 \pm 2^{\circ}\text{C}$ 2. Time: 1000 hours 3. Measured at room temperature after placing for 24 ± 2 hours
High temperature storage	Inductance change: Within $\pm 10\%$ Without distinct damage in visual	1. Temperature: $+125 \pm 2^{\circ}\text{C}$ 2. Time: 1000 hours 3. Measured at room temperature after placing for 24 ± 2 hours

◆ Recommended Soldering Technologies

(1) Re-flowing Profile

Preheat condition: 150 ~200°C/60~180sec.

Allowed time above 217°C: 80~120sec.

Max temp: 260°C

Max time at max temp: 10 sec.

Solder paste: Sn/3.0Ag/0.5Cu

Allowed Reflow time: 2x max

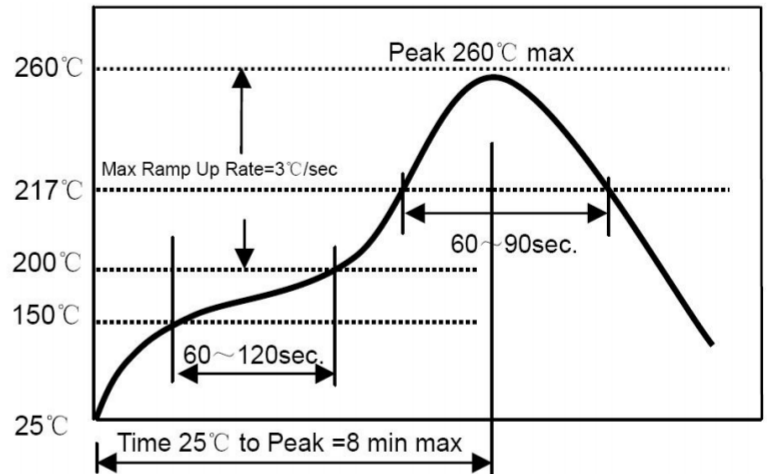

(2) Iron Soldering Profile

Iron soldering power: Max. 30W

Pre-heating: 150°C/60sec.

Soldering time: 3sec. Max.

Solder paste: Sn/3.0Ag/0.5Cu

Max.1 times for iron soldering

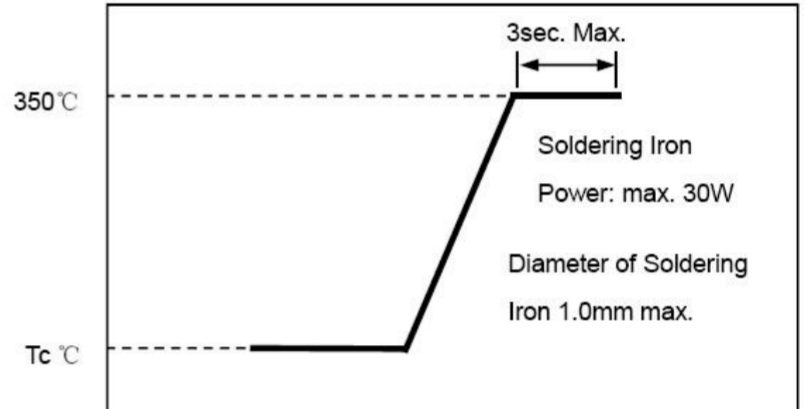

◆ Packaging:150PCS/Reel

X-ON Electronics

Largest Supplier of Electrical and Electronic Components

Click to view similar products for [Fixed Inductors](#) category:

Click to view products by [Sunltech](#) manufacturer:

Other Similar products are found below :

[CR32NP-100KC](#) [70F224AI](#) [MHQ1005P10NJ](#) [MHQ1005P1N0S](#) [MHQ1005P2N4S](#) [MHQ1005P3N6S](#) [MHQ1005P5N1S](#) [MHQ1005P8N2J](#)
[PE-53601NL](#) [PE-53602NL](#) [PG0936.113NLT](#) [9220-20](#) [9310-16](#) [PM06-2N7](#) [PM06-39NJ](#) [A01TK](#) [1206CS-471XJ](#) [HC2-R47-R](#) [HC8-1R2-R](#)
[HCF1305-3R3-R](#) [1206CS-151XG](#) [RCH664NP-4R7M](#) [RCP1317NP-391L](#) [DH2280-4R7M](#) [DS1608C-106](#) [B10TJ](#) [B82498B3101J000](#) [ELJ-](#)
[RE27NJF2](#) [1812CS-153XJ](#) [1812CS-183XJ](#) [1812CS-223XJ](#) [1812LS-104XJ](#) [1812LS-105XJ](#) [1812LS-124XJ](#) [1812LS-154XJ](#) [1812LS-223XJ](#)
[1812LS-224XJ](#) [1812LS-563XJ](#) [1812LS-683XJ](#) [1812LS-824XJ](#) [NIN-FB101JTR110F](#) [NIN-FB471JTR62F](#) [NIN-FC1R5JTR220F](#) [NIN-](#)
[HCR15JTRF](#) [NIN-HCR33JTRF](#) [NIN-HDR22JTRF](#) [NIN-HDR82JTRF](#) [NIN-HK2N7STRF](#) [NIN-PA150KTR370F](#) [NIN-PB100KTR550F](#)