

**SMD Molding Power Inductor**

**◆ Features:**

1. Metal material for large current and low loss
2. High performance (Isat) realized by metal dust core
3. Low loss realized with low Rdc
4. Closed magnetic circuit design reduces leakage flux
5. Vinyl thermal spray, better surface compactness|
6. 100% lead (Pb) free meet RoHS standard

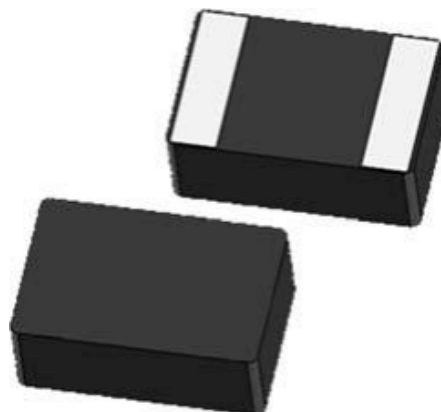

**◆ Application**

1. DC/DC converters
2. Pad Smartphone
3. Portable gaming devices, Smart wear, Wi-Fi module
4. Notebooks VR AR
5. LCD displays, HDDs DVCs DSDs etc
6. Base and power supply, Amplifier, Power management Module power supply, Camera power manage me

**◆ Lead Free Part Numbering**

**SLO 322512 T R22 M T T**  
**(1) (2) (3) (4) (5) (6) (7)**

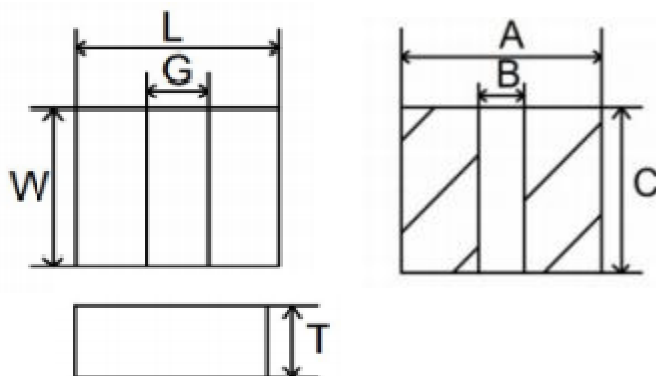
- (1). Series Type
- (2). Dimension: LxGxW
- (3). Material Code
- (4). Inductance: R22=0.22uH 2R2=2.2uH
- (5). Inductance Tolerance: M=±20% N=±30%
- (6). Company Code
- (7). Packaging: Packed in embossed carrier tape



Series	L	G	W	T	A	B	C
SLO322512T	3.2±0.2	0.9±0.2	2.5±0.2	1.2 MAX	3.25	0.90	2.55

**◆ Specifications**

Part Number	L0(uH) @ (0A) 1MHz ±20%	Rdc(mΩ)		Heat rating current Irms(A)		Saturation current Iast(A)	
		Typical	Max	Typical	Max	Typical	Max
SLO322512TR10MTT	0.10	5.2	7.0	12.0	11.0	18.0	16.5
SLO322512TR22MTT	0.22	6.6	10.0	9.2	8.7	11.5	11.0
SLO322512TR24MTT	0.24	7.0	12.0	9.0	8.5	11.0	10.5
SLO322512TR33MTT	0.33	9.0	14.0	8.4	8.1	10.0	9.5
SLO322512TR47MTT	0.47	14.0	19.0	7.5	7.2	8.6	8.2
SLO322512TR68MTT	0.68	18.0	23.0	7.3	6.8	8.1	7.7
SLO322512T1R0MTT	1.0	26.0	30.0	5.3	4.8	6.6	5.8
SLO322512T1R5MTT	1.5	37.0	44.0	4.7	4.3	5.1	4.7
SLO322512T2R2MTT	2.2	58.0	70.0	3.6	3.0	4.6	4.2
SLO322512T3R3MTT	3.3	75.0	95.0	2.9	2.5	3.7	3.2
SLO322512T4R7MTT	4.7	115.0	135.0	2.3	2.0	2.9	2.6
SLO322512T6R8MTT	6.8	177.0	210.0	2.1	1.9	2.8	2.4
SLO322512T100MTT	10.0	210.0	230.0	2.2	1.8	2.3	1.9

**◆ Soldering Condition**

This is for recommendation, please customer perform adjustment according to actual application  
 Recommend Reflow Soldering Profile: (solder: Sn96.5/Ag3/Cu0.5)

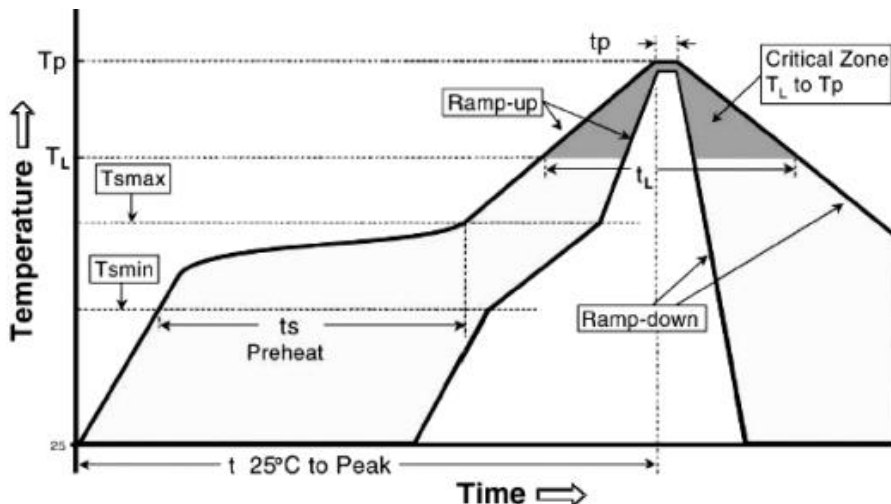

Profile Feature	Lead (Pb)-Free solder
Preheat: Temperature Min (T <sub>smin</sub> ) Temperature Max (T <sub>smax</sub> ) Time (T <sub>smin</sub> to T <sub>smax</sub> ) (ts)	150°C 200°C 60-120 seconds
Average ramp-up rate: (T <sub>s max</sub> to T <sub>p</sub> )	3°C/second max.
Time maintained above Temperature (T <sub>L</sub> ) Time (T <sub>L</sub> )	217°C 60-150 seconds
Peak Temperature (T <sub>p</sub> )	260°C
Time within+0-5 °C of actual peak Temperature (T <sub>p</sub> ) <sup>2</sup>	10 seconds
Ramp-down Rate	6°C/second max
Time 25 °C to Peak Temperature	8minutes max

Allowed Re-flow times:2 times

Remark:To avoid discoloration phenomena of chip on terminal electrodes,please use N2 Re-flow furnace

◆ **Packing:3000PCS/Reel**

**◆ Reliability**

Item	Requirement	Test Methods and Remarks
<b>Insulation Resistance</b>	$\geq 100M\Omega$	100 VDC between inductor coil and The middle of the top surface of the body for 60 seconds
<b>Solder ability</b>	90% or more of electrode area shall be coated by new solder	Dip pads in flux Solder Composition: Sn/Ag3.0/Cu0.5(Pb-Free) Solder Temperature: 245±5 °C Immersion Time: (5±1) s
<b>Resistance to Soldering Heat</b>	No visible mechanical damage Inductance change: Within ±10%	Dip pads in flux Solder Composition: Sn/Ag3.0/Cu0.5(Pb-Free) Solder Temperature: 260±5 °C Immersion Time: 10±1sec
<b>Adhesion of teral electrode</b>	Strong bond between the pad and the core, without come off PCB	Inductors shall be subjected to (260±5)°C for (20±5)s Soldering in the base whit 0.3mm solder And then aplombelectrode way plus tax 10 N for (10±1) seconds
<b>High temperature</b>	No case deformation or change in appearance Inductance change: Within ±10%	Temperature: -40±2 °C Time : 1000 hours Measurement at 24±4 hours after test conclusion
<b>Low temperature</b>	No visible mechanical damage Inductance change: Within ±10%	Temperature: -40±2 °C Time : 1000 hours Measurement at 24±4 hours after test conclusion
<b>Thermal shock</b>	No visible mechanical damage Inductance change: Within ±10%	The test sample shall be placed at (-55±3)°C and (125±3)°C for (30±3) , different temperature conversion time is 2~3 utes The temperature cycle shall be repeated 32 cycles Placed at room temperature for 2 hours, within 48±4 hours of testing
<b>Temperature characteristic</b>	Inductance change Pc-b,Pc-d Within ±10%	a:+20 °C (30~45) b:-40 °C (30~45) c:+20 °C (30~45) d:+125 °C (30~45) e:+20 °C (30~45) $P_{c-b} = \frac{L_b - L_c}{L_c} \times 100\%$ $P_{c-d} = \frac{L_d - L_c}{L_c} \times 100\%$
<b>Static Humidity</b>	No visible mechanical damage Inductance change: Within ±10%	Inductors shall be subjected to (95±3)%RH at(60±2)°C for (1000±4) h Placed at room temperature for 2 hours, within 48 hours of testing
<b>Life</b>	No visible mechanical damage Inductance change: Within ±10%	Inductors shall be store at (85±2)°C for (1000±4) hours with Irms applied Placed at room temperature for 2 hours, within 48 hours of testing.

## X-ON Electronics

Largest Supplier of Electrical and Electronic Components

*Click to view similar products for [Fixed Inductors](#) category:*

*Click to view products by [Sunltech](#) manufacturer:*

Other Similar products are found below :

[CR32NP-100KC](#) [70F224AI](#) [MHQ1005P10NJ](#) [MHQ1005P1N0S](#) [MHQ1005P2N4S](#) [MHQ1005P3N6S](#) [MHQ1005P5N1S](#) [MHQ1005P8N2J](#)  
[PE-53601NL](#) [PE-53602NL](#) [PG0936.113NLT](#) [9220-20](#) [9310-16](#) [PM06-2N7](#) [PM06-39NJ](#) [A01TK](#) [1206CS-471XJ](#) [HC2-R47-R](#) [HC8-1R2-R](#)  
[HCF1305-3R3-R](#) [1206CS-151XG](#) [RCH664NP-4R7M](#) [RCP1317NP-391L](#) [DH2280-4R7M](#) [DS1608C-106](#) [B10TJ](#) [B82498B3101J000](#) [ELJ-](#)  
[RE27NJF2](#) [1812CS-153XJ](#) [1812CS-183XJ](#) [1812CS-223XJ](#) [1812LS-104XJ](#) [1812LS-105XJ](#) [1812LS-124XJ](#) [1812LS-154XJ](#) [1812LS-223XJ](#)  
[1812LS-224XJ](#) [1812LS-563XJ](#) [1812LS-683XJ](#) [1812LS-824XJ](#) [NIN-FB101JTR110F](#) [NIN-FB471JTR62F](#) [NIN-FC1R5JTR220F](#) [NIN-](#)  
[HCR15JTRF](#) [NIN-HCR33JTRF](#) [NIN-HDR22JTRF](#) [NIN-HDR82JTRF](#) [NIN-HK2N7STRF](#) [NIN-PA150KTR370F](#) [NIN-PB100KTR550F](#)