

# AC Axial Fan & Blower



\*All products are **RoHS** compliance.



**SUNON®**

## Sunon AC Axial Fan & Blower

			Page
Engineering Information			page 02
Fan Model Numbering System			page 04
AC Fan Series		Air Flow (CFM)	
<b>NEW</b>	60x60x25mm (MagLev Motor AC Fan)	17.5~18	page 05
<b>NEW</b>	70x70x25mm (MagLev Motor AC Fan)	28~29	page 06
<b>NEW</b>	80x80x25 mm (MagLev Motor AC Fan)	40~41	page 07
	80x80x25mm	17~22	page 08
	80x80x38mm	23~31	page 09
<b>NEW</b>	92x92x25mm (MagLev Motor AC Fan)	52~54	page 10
	92x92x25mm	21~37	page 11
	120x120x25mm (115V)	46~80	page 12
	120x120x25mm (220-240V)	46~80	page 13
	120x120x38mm (115V)?	70~117	page 14
	120x120x38mm (220-240V)	70~117	page 15
	120x120x38mm (Plastic Frame)	85~100	page 16
<b>NEW</b>	120x120x38mm (New Type)	95~117	page 17
	120x120x38mm (Dual AC Voltage)	95~115	page 18
	171x151x51mm	180~200	page 19
	171x151x51mm ( Alveolate Motor)	203~239	page 20
	∅171x51mm ( Alveolate Motor)	203~239	page 21
	176x176x89mm ( Alveolate Motor)	315~355	page 22
<b>NEW</b>	∅254x89mm ( Alveolate Motor)	425~870	page 23
	120x120x31mm (Blower)	20~22	Page 24

### Certification



### Safety



## MagLev Frequency-Switching Motor (MagLev AC Fan)

 Low Power Consumption  Super High Airflow  Smart Multi-functional Controls

Sunon MagLev AC Fans with MagLev Frequency-Switching Motors, not only contain the three features of low noise, high temperature endurance, and super long life inherited from the MagLev motor design, but also are superior in low power consumption, super high airflow, and smart multi-functional controls. By adopting the design principle of frequency-switching circuit controls, Sunon MagLev AC Fans are the best solution for AC-powered cooling.

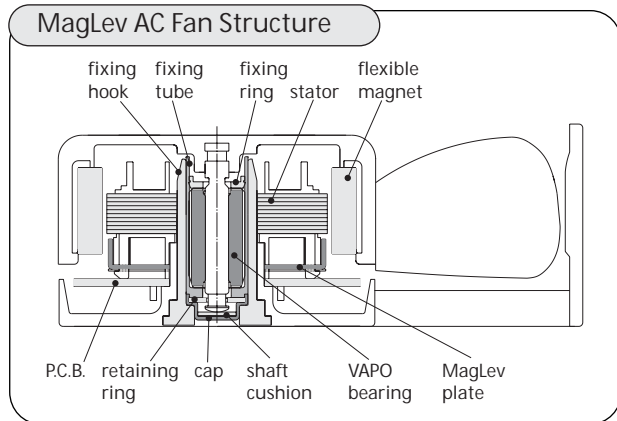

### MagLev AC Fans compared with conventional AC fans

#### MagLev AC Fan

1. Due to the patented design, Sunon MagLev AC Fan's hub area is significantly reduced, yielding a larger impeller which can offer double the airflow of conventional AC fans.
2. Rotational speed can be adjusted per customer's requirement.
3. Frequency-switching circuit design can reduce the power consumption to less than half that of conventional AC fans. With an input voltage of 115V/50Hz, the 80mm AC fans offer power consumptions of only 3.6W.
4. Provides output signal for rotational speed detection.
5. The MagLev design, with its compact size features low noise.
6. By rotating with full exertion in a fixed operational orbit, the MagLev AC fan eliminates vibration and prolongs lifespan.
7. MagLev AC Fans with its novel technology goes beyond the norm and provides unlimited possibilities for customers' future demands.

#### Conventional AC fan

1. Limited by the motor-wire wrapping process, the resulting motor hube is larger than MagLev AC fans.
2. Limited rotational speed, can't adjust to customers demand for the highest rotational speed.
3. When directly connected to AC power supplies, the power consumption is higher.
4. It's difficult for conventional motor design to provide output signal for torational speed detection.
5. Conventional AC fans have encountered a bottleneck in their technical development, and therefore it is difficult to make any further break through.

*Alveolate Motor AC fan series with automatic motor-wire wrapping technology ensures stable performance of high wind volume, low acoustic noise, also available with functions of dual spinning rate, and thermal cutout.*



## SUNON-Alveolate Motor VS. Traditional Shaded-Pole Motor

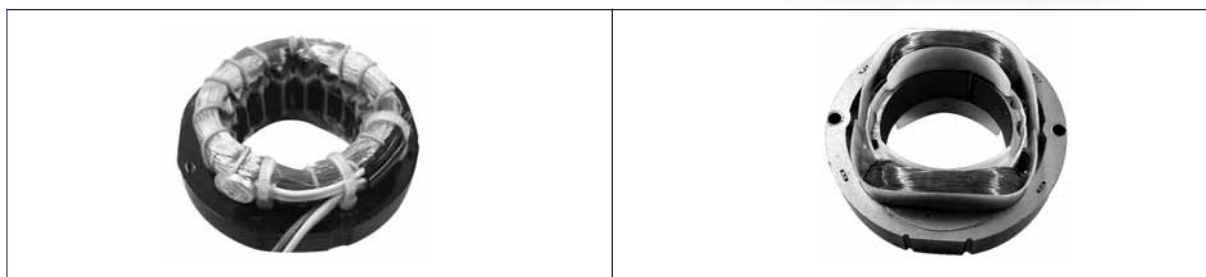

SUNON-Alveolate Motor	Traditional Shaded-Pole Motor
1. The Alveolate Motor is equipped with starting stator coils and working ones. The starting coils form a low starting voltage with the capacitors. For example, an 115VAC (the fixed voltage) Alveolate Motor can be started with 60VAC.	1. The Traditional Shaded-Pole Motor, designed with single-wire wrapping, is started by "the starting copper" and cannot be started with low voltage. An 115VAC Traditional Shaded-Pole motor will need more than 80VAC to run, 20VAC more than the Alveolate one.
2. The coils do not produce high temperature and consumes less electricity. The temperature is normally around 50°C. Therefore, the motor is always stable and reliable.	2. The Traditional Shaded-Pole Motor consumes electricity twice as much as the Alveolate Motor. It is not reliable because the temperature is usually higher than 70°C.
3. The Thermal Cutout can protect the motor.	3. The Thermal Cutout is an option.
4. The motor has a large torsion to produce high wind pressure and wind volume.	4. General wind pressure and wind volume.
5. The motor is equipped with the third wire, ready to comply with the customer's systems.	5. Without the third wire.

## General AC Fan

Ex) **SF11580AT 1 08 2 H B L .GN**

### MODEL SERIES

SFxxx  
SPxxx  
DPxxx

### VOLTAGE

1 : 115 VAC  
2 : 220 -240 VAC

### FRAME SIZE

08 : 80 mm  
09 : 92 mm  
12 : 120 mm

### FRAME THICKNESS

2 : 25 mm  
3 : 38 mm

RoHS Compliance

### TERMINALS

T : Terminal  
L : Lead wire

### BEARING SYSTEM

B : Ball  
S : Sleeve

### SPEED

X : Super  
H : High  
M : Middle  
L : Low

## New Type AC Fan

Ex) **A 1 17 5 - H B T**

### MODEL SERIES

A : New AC fan series  
AB : New AC blower series  
MA : MagLev AC Fan series

### VOLTAGE

1 : 115 VAC      3 : 380 VAC  
2 : 220-240 VAC

### FRAME SIZE

08 : 80 mm      17 : 172 mm  
09 : 92 mm      25 : 254 mm  
12 : 120 mm

### FRAME THICKNESS

2 : 25 mm      7 : 72 mm  
3 : 31~38mm      9 : 89~90mm  
5 : 50~51 mm

### TERMINALS

T : Terminal  
L : Lead wire

### BEARING SYSTEM

V : MagLev  
S : Sleeve  
B : Ball

### SPEED

X : Super  
H : High  
M : Middle  
L : Low

## P/N

P/N Suffixes have the following significance :

- T : Thermal Cutout
- C : Capacitor
- TC : Alveolate Motor with Thermal Cutout and Capacitor
- TC.R : Round Frame , Alveolate Motor with Thermal Cutout and Capacitor
- N : New frame
- GN : RoHS compliance

\* Alveolate Motor only available in P/N : TC model

## MagLev Motor AC Fan

### 17.5-18 CFM

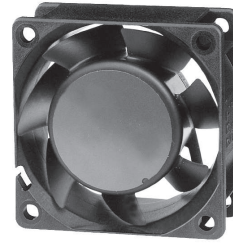

Model	P/N	Bearing ● VAPO ○ BALL ◎ Sleeve	Rating Voltage (VAC)	Freq. (Hz)	Power Current (AMP)	Power Consumption (WATTS)	Speed (RPM)	Air Flow (CFM)	Static Pressure (Inch-H <sub>2</sub> O)	Noise (dBA)	Weight (g)
MA1062-HVL	GN	●	115	50/60	0.191/0.185	3.6/3.6	4100/4200	17.5/18	0.19/0.20	30/31	81
MA2062-HVL	GN	●	220-240	50/60	0.198/0.211	4.1/4.4	4100/4200	17.5/18	0.19/0.20	30/31	81

Frame : PBT Plastic

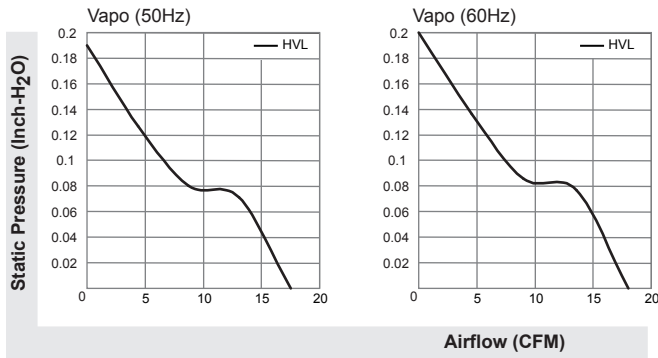

UNITS:mm

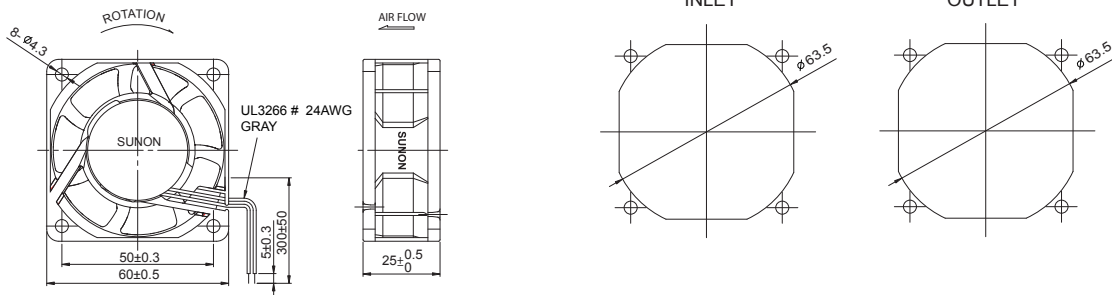

\*All model could be customized on voltage or any other requirements to fit your need.

\*Specifications subject to change without notice. Please Visit SUNON web site at <http://www.sunon.com> for update information.

## MagLev Motor AC Fan

### 28-29 CFM

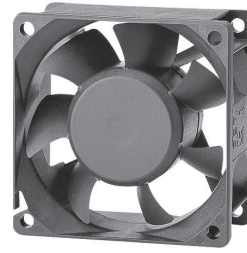

Model	P/N	Bearing	Rating Voltage (VAC)	Freq. (Hz)	Power Current (AMP)	Power Consumption (WATTS)	Speed (RPM)	Air Flow (CFM)	Static Pressure (Inch-H <sub>2</sub> O)	Noise (dBA)	Weight (g)
MA1072-HVL	GN	● Vapo ○ BALL ◎ Sleeve	115	50/60	0.208/0.197	3.7/3.7	3800/3900	28/29	0.17/0.18	30/31	90
MA2072-HVL	GN	●	220-240	50/60	0.207/0.220	4.3/4.4	3800/3900	28/29	0.17/0.18	30/31	90

Frame : PBT Plastic

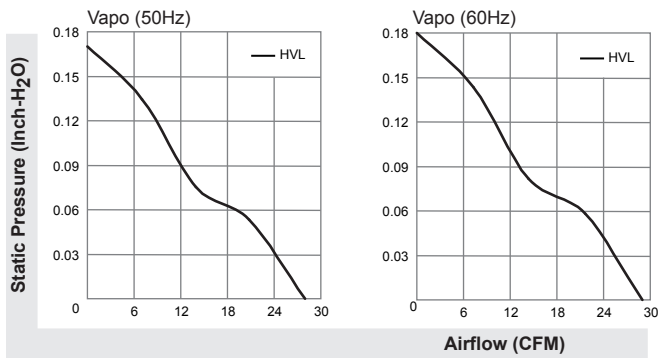

UNITS:mm

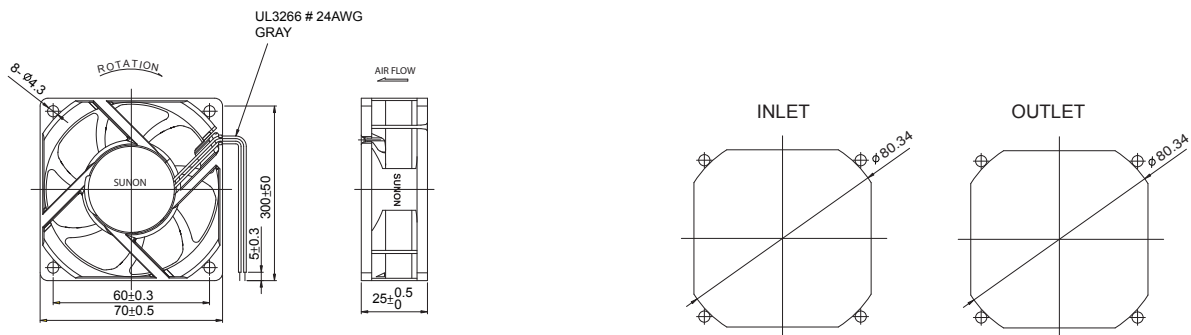

\*All model could be customized on voltage or any other requirements to fit your need.

\*Specifications subject to change without notice. Please Visit SUNON web site at <http://www.sunon.com> for update information.

## MagLev Motor AC Fan

### 40-41 CFM



Model	P/N	Bearing	Rating Voltage (VAC)	Freq. (Hz)	Power Current (AMP)	Power Consumption (WATTS)	Speed (RPM)	Air Flow (CFM)	Static Pressure (Inch-H <sub>2</sub> O)	Noise (dBA)	Weight (g)
MA1082-HVL	GN	● Vapo ○ BALL ◎ Sleeve	115	50/60	0.112/0.116	3.6/3.6	3200/3300	40/41	0.14/0.15	32/33	102.2
MA2082-HVL	GN	●	220-240	50/60	0.102/0.101	4.6/4.6	3200/3300	40/41	0.14/0.15	32/33	102.2

Frame : PBT Plastic

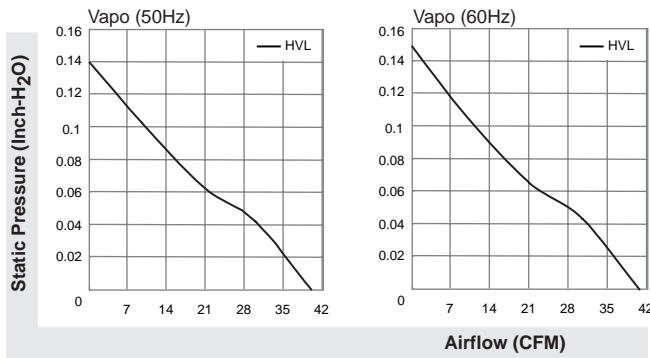

UNITS:mm

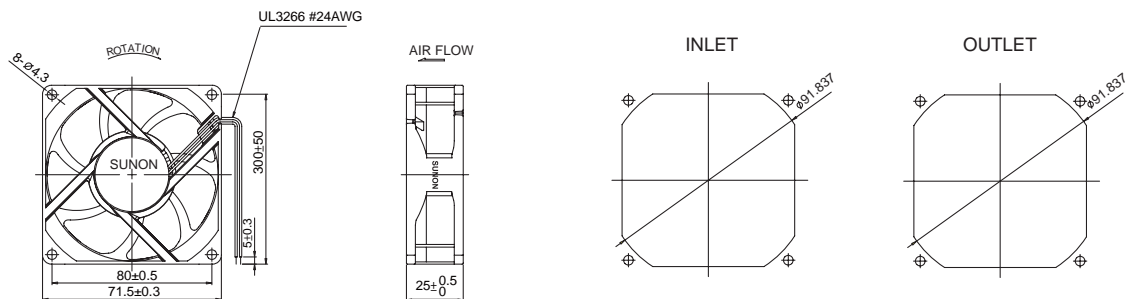

\*All model could be customized on voltage or any other requirements to fit your need.

\*Specifications subject to change without notice. Please Visit SUNON web site at <http://www.sunon.com> for update information.



## 17-22CFM



Model	P/N	Bearing ● VAPO ○ BALL ⊙ Sleeve	Rating Voltage (VAC)	Freq. (Hz)	Power Current (AMP)	Power Consumption (WATTS)	Speed (RPM)	Air Flow (CFM)	Static Pressure (Inch-H <sub>2</sub> O)	Noise (dBA)	Weight (g)
SF11580AT	1082HSL.GN	⊙	115	50/60	0.12/0.10	12/11	2300/2750	17/21	0.12/0.18	29/33	260
SF11580AT	1082HBL.GN	○	115	50/60	0.12/0.10	12/11	2450/2900	18/22	0.13/0.19	30/34.5	260
SF23080AT	2082HSL.GN	⊙	220-240	50/60	0.07/0.07	14/13.5	2300/2750	17/21	0.12/0.18	29/33	260
SF23080AT	2082HBL.GN	○	220-240	50/60	0.07/0.07	14/13.5	2450/2900	18/22	0.13/0.19	30/34.5	260

Frame : Aluminum alloy

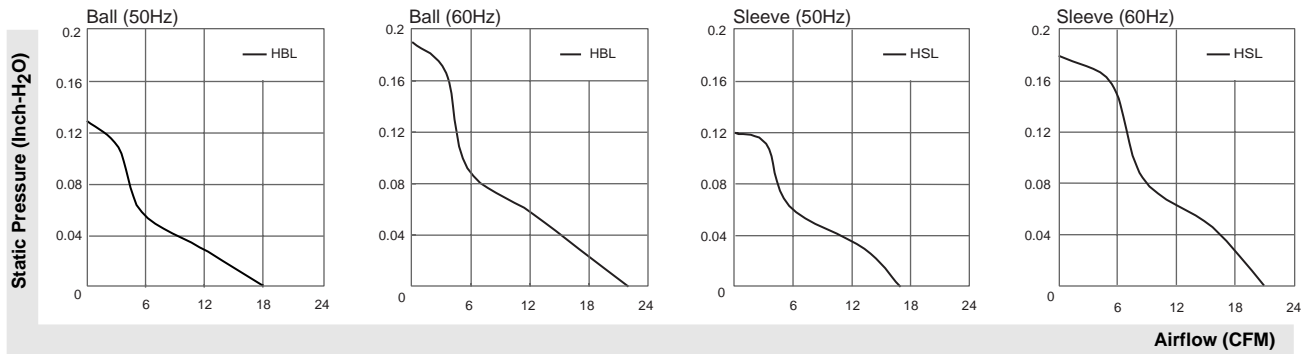

UNITS:mm

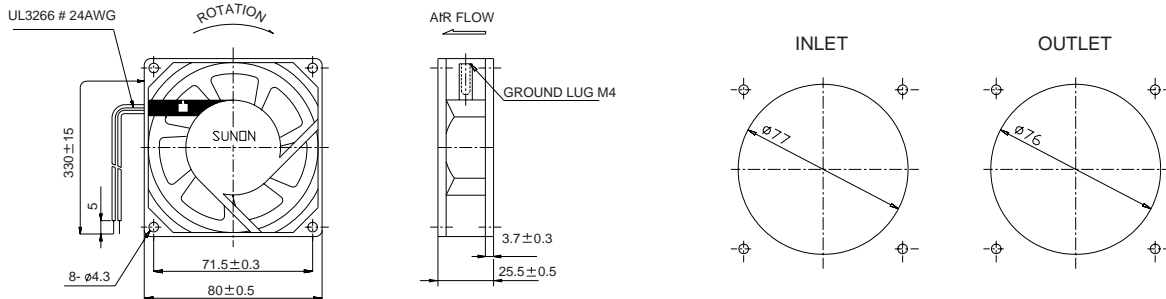

\*All model could be customized on voltage or any other requirements to fit your need.

\*Specifications subject to change without notice. Please Visit SUNON web site at <http://www.sunon.com> for update information.

## 23-31CFM



Model	P/N	Bearing ● VAPO ○ BALL ⊙ Sleeve	Rating Voltage (VAC)	Freq. (Hz)	Power Current (AMP)	Power Consumption (WATTS)	Speed (RPM)	Air Flow (CFM)	Static Pressure (Inch-H <sub>2</sub> O)	Noise (dBA)	Weight (g)
SF11580A	1083HSL.GN	⊙	115	50/60	0.15/0.13	14/12	2300/2750	23/30	0.12/0.18	31/35	340
SF11580A	1083HBL.GN	○	115	50/60	0.15/0.13	14/12	2400/2850	24/31	0.13/0.19	32/36.5	340
SF23080A	2083HSL.GN	⊙	220-240	50/60	0.09/0.08	18/16	2300/2750	23/30	0.12/0.18	31/35	340
SF23080A	2083HBL.GN	○	220-240	50/60	0.09/0.08	18/16	2400/2850	24/31	0.13/0.19	32/36.5	340

Frame : Aluminum alloy

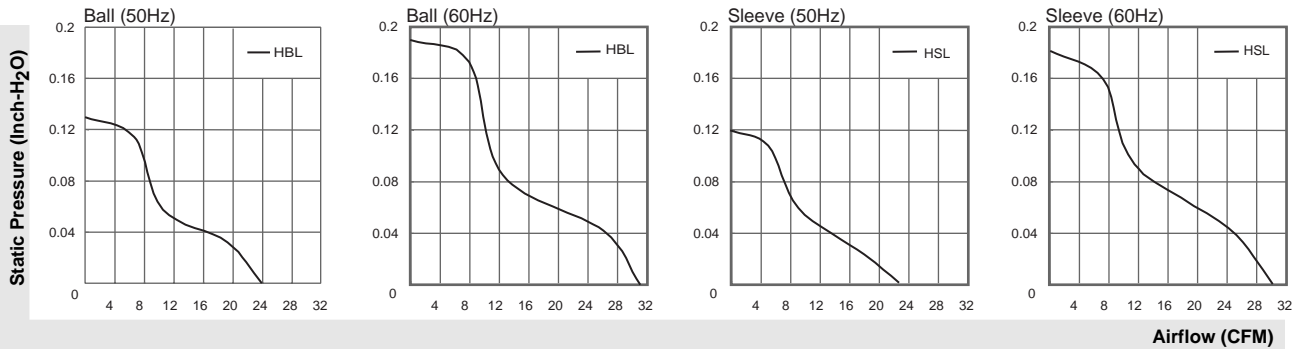

UNITS:mm

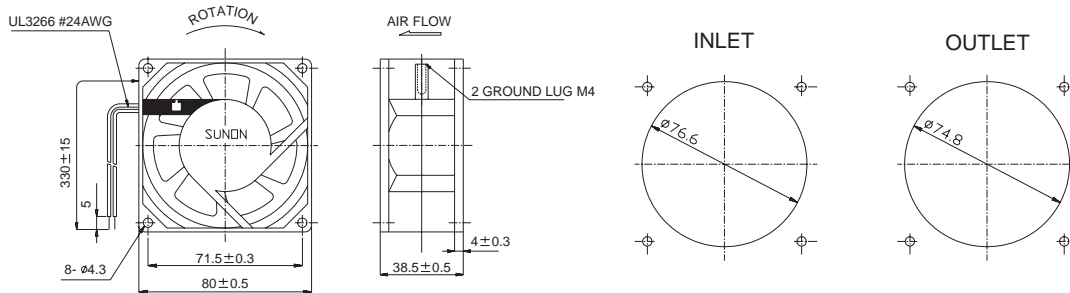

\*All model could be customized on voltage or any other requirements to fit your need.

\*Specifications subject to change without notice. Please Visit SUNON web site at <http://www.sunon.com> for update information.

## MagLev Motor AC Fan

### 52-54 CFM



Model	P/N	Bearing ● VAPO ○ BALL ◎ Sleeve	Rating Voltage (VAC)	Freq. (Hz)	Power Current (AMP)	Power Consumption (WATTS)	Speed (RPM)	Air Flow (CFM)	Static Pressure (Inch-H <sub>2</sub> O)	Noise (dBA)	Weight (g)
MA1092-HVL	GN	●	115	50/60	0.114/0.118	3.6/3.6	2900/3000	52/54	0.12/0.14	31/32	119.7
MA2092-HVL	GN	●	220-240	50/60	0.103/0.106	4.6/4.6	2900/3000	52/54	0.12/0.14	31/32	119.7

Frame : PBT Plastic

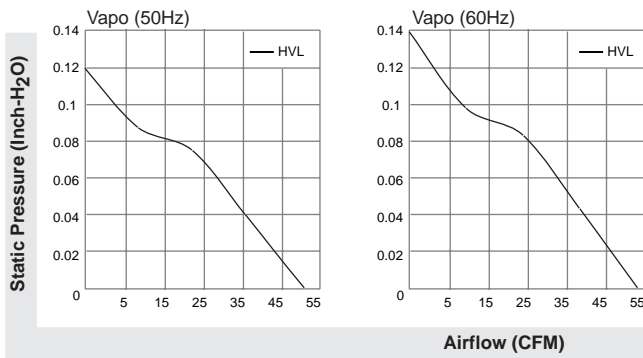

UNITS:mm

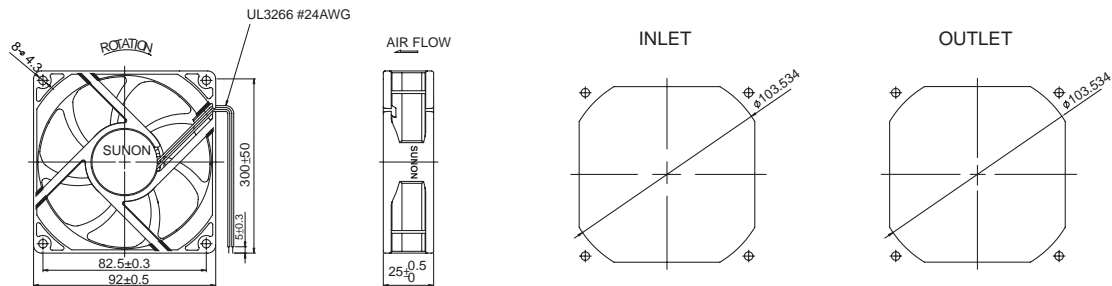

\*All model could be customized on voltage or any other requirements to fit your need.

\*Specifications subject to change without notice. Please Visit SUNON web site at <http://www.sunon.com> for update information.

21-37 CFM



Model	P/N	Bearing	Rating Voltage (VAC)	Freq. (Hz)	Power Current (AMP)	Power Consumption (WATTS)	Speed (RPM)	Air Flow (CFM)	Static Pressure (Inch-H <sub>2</sub> O)	Noise (dBA)	Weight (g)
SF11592A	1092HSL.GN	⊙	115	50/60	0.12/0.11	13/12	2250/2750	29/36	0.12/0.18	36/39	280
SF11592A	1092HST.GN	⊙	115	50/60	0.12/0.11	13/12	2250/2750	29/36	0.12/0.18	36/39	280
SF11592A	1092MSL.GN	⊙	115	50/60	0.06/0.06	7/6	1550/1700	21/26	0.08/0.09	28/30	280
SF11592A	1092MST.GN	⊙	115	50/60	0.06/0.06	7/6	1550/1700	21/26	0.08/0.09	28/30	280
SF11592A	1092HBL.GN	○	115	50/60	0.12/0.11	13/12	2350/2850	30/37	0.13/0.19	37/40	280
SF11592A	1092HBT.GN	○	115	50/60	0.12/0.11	13/12	2350/2850	30/37	0.13/0.19	37/40	280
SF11592A	1092MBL.GN	○	115	50/60	0.07/0.06	7/6	1800/2100	23/28	0.10/0.11	31/33	280
SF11592A	1092MBT.GN	○	115	50/60	0.07/0.06	7/6	1800/2100	23/28	0.10/0.11	31/33	280
SF23092A	2092HSL.GN	⊙	220-240	50/60	0.07/0.06	14.5/14	2250/2750	29/36	0.12/0.18	36/39	280
SF23092A	2092HST.GN	⊙	220-240	50/60	0.07/0.06	14.5/14	2250/2750	29/36	0.12/0.18	36/39	280
SF23092A	2092MSL.GN	⊙	220-240	50/60	0.07/0.07	15/14	2000/2500	27/33	0.11/0.16	32/37	280
SF23092A	2092MST.GN	⊙	220-240	50/60	0.07/0.07	15/14	2000/2500	27/33	0.11/0.16	32/37	280
SF23092A	2092HBL.GN	○	220-240	50/60	0.07/0.06	14.5/14	2350/2850	30/37	0.13/0.19	37/40	280
SF23092A	2092HBT.GN	○	220-240	50/60	0.07/0.06	14.5/14	2350/2850	30/37	0.13/0.19	37/40	280
SF23092A	2092MBL.GN	○	220-240	50/60	0.07/0.07	15/14	2200/2700	28/35	0.12/0.18	35/38	280
SF23092A	2092MBT.GN	○	220-240	50/60	0.07/0.07	15/14	2200/2700	28/35	0.12/0.18	35/38	280

Frame : Aluminum alloy

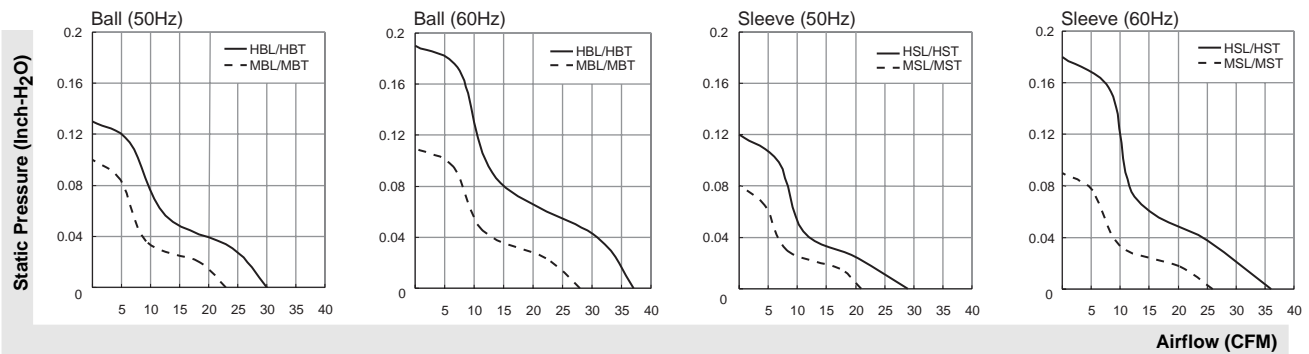

UNITS:mm

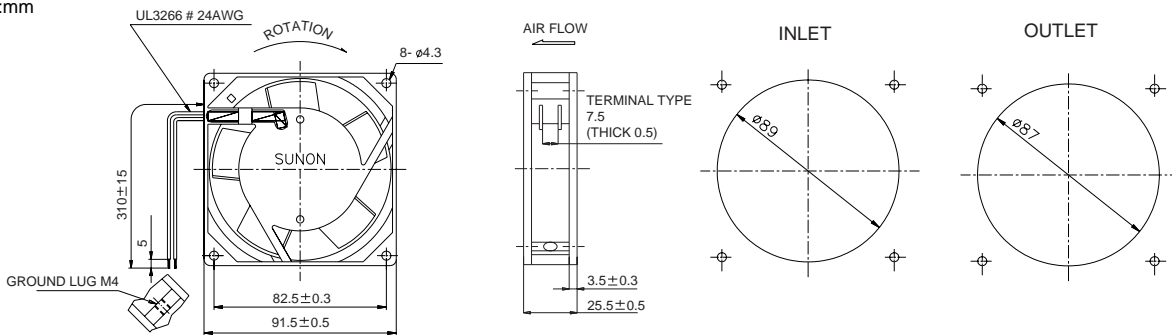

\*All model could be customized on voltage or any other requirements to fit your need.

\*Specifications subject to change without notice. Please Visit SUNON web site at <http://www.sunon.com> for update information.

## 46-80 CFM



Model	P/N	Bearing	Rating Voltage (VAC)	Freq. (Hz)	Power Current (AMP)	Power Consumption (WATTS)	Speed (RPM)	Air Flow (CFM)	Static Pressure (Inch-H <sub>2</sub> O)	Noise (dBA)	Weight (g)
SP101AT	1122HSL.GN	⊙	115	50/60	0.21/0.19	19/18	2000/2300	64/78	0.13/0.16	43/46	330
SP101AT	1122HST.GN	⊙	115	50/60	0.21/0.19	19/18	2000/2300	64/78	0.13/0.16	43/46	330
SP103AT	1122LSL.GN	⊙	115	50/60	0.14/0.13	14/13	1600/1800	46/53	0.11/0.12	35/38	330
SP103AT	1122LST.GN	⊙	115	50/60	0.14/0.13	14/13	1600/1800	46/53	0.11/0.12	35/38	330
SP101AT	1122HBL.GN	○	115	50/60	0.21/0.19	19/18	2150/2500	66/80	0.14/0.17	44/48	330
SP101AT	1122HBT.GN	○	115	50/60	0.21/0.19	19/18	2150/2500	66/80	0.14/0.17	44/48	330
SP103AT	1122LBL.GN	○	115	50/60	0.12/0.11	12.5/11.5	1700/1900	47/54	0.12/0.13	37/40	330
SP103AT	1122LBT.GN	○	115	50/60	0.12/0.11	12.5/11.5	1700/1900	47/54	0.12/0.13	37/40	330

Frame : Aluminum alloy

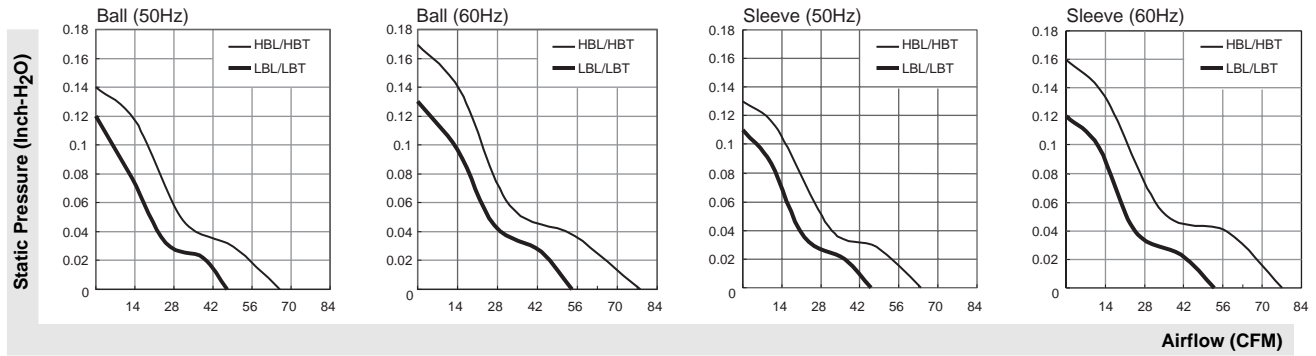

UNITS:mm

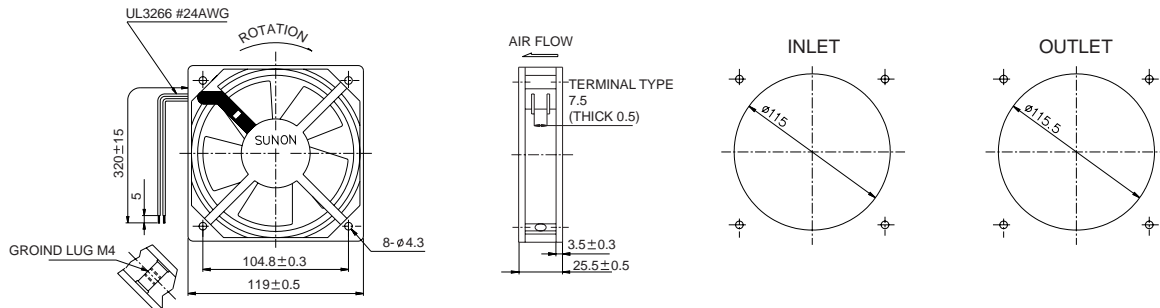

\*All model could be customized on voltage or any other requirements to fit your need.

\*Specifications subject to change without notice. Please Visit SUNON web site at <http://www.sunon.com> for update information.

## 46-80 CFM



Model	P/N	Bearing	Rating Voltage (VAC)	Freq. (Hz)	Power Current (AMP)	Power Consumption (WATTS)	Speed (RPM)	Air Flow (CFM)	Static Pressure (Inch-H <sub>2</sub> O)	Noise (dBA)	Weight (g)
DP201AT	2122HSL.GN	⊙	220-240	50/60	0.10/0.09	19/19	2000/2300	64/78	0.13/0.16	43/46	330
DP201AT	2122HST.GN	⊙	220-240	50/60	0.10/0.09	19/19	2000/2300	64/78	0.13/0.16	43/46	330
DP203AT	2122LSL.GN	⊙	220-240	50/60	0.07/0.07	14/13	1600/1800	46/53	0.11/0.12	35/38	330
DP203AT	2122LST.GN	⊙	220-240	50/60	0.07/0.07	14/13	1600/1800	46/53	0.11/0.12	35/38	330
DP201AT	2122HBL.GN	○	220-240	50/60	0.10/0.09	19/18	2150/2500	66/80	0.14/0.17	44/48	330
DP201AT	2122HBT.GN	○	220-240	50/60	0.10/0.09	19/18	2150/2500	66/80	0.14/0.17	44/48	330
DP203AT	2122LBL.GN	○	220-240	50/60	0.07/0.07	14/13	1700/1900	47/54	0.12/0.13	37/40	330
DP203AT	2122LBT.GN	○	220-240	50/60	0.07/0.07	14/13	1700/1900	47/54	0.12/0.13	37/40	330

Frame : Aluminum alloy

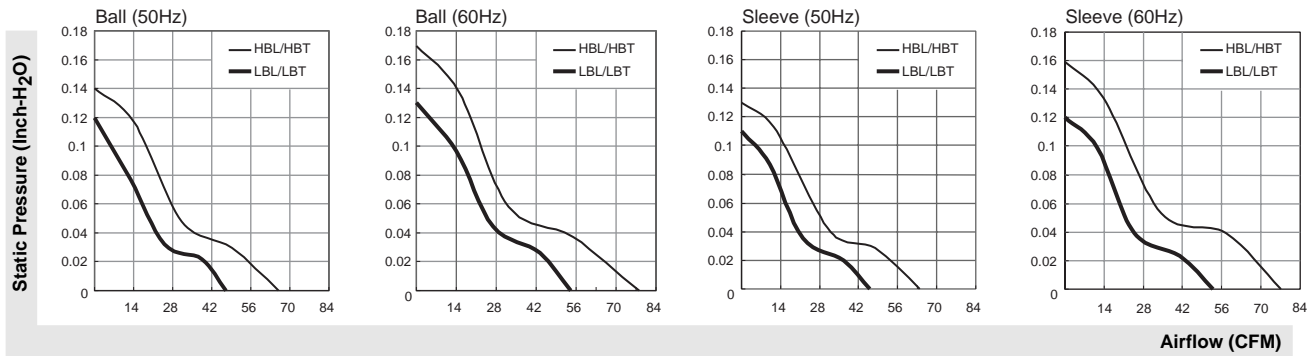

UNITS:mm

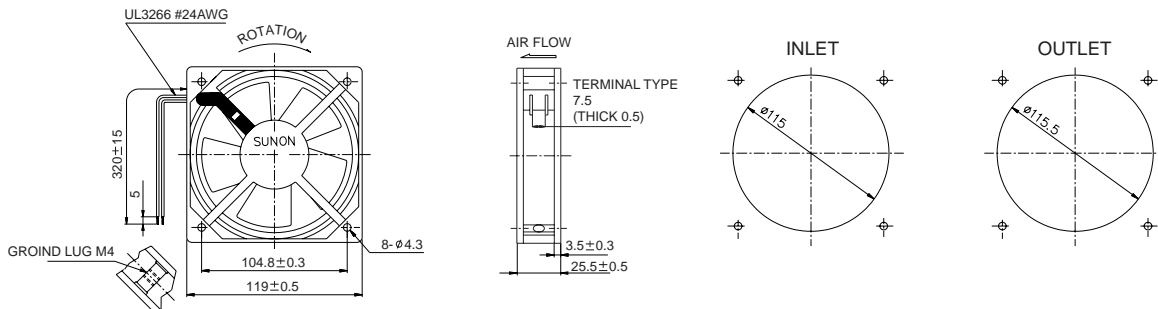

\*All model could be customized on voltage or any other requirements to fit your need.

\*Specifications subject to change without notice. Please Visit SUNON web site at <http://www.sunon.com> for update information.

## 70-117CFM



Model	P/N	Bearing ● VAPO ○ BALL ◎ Sleeve	Rating Voltage (VAC)	Freq. (Hz)	Power Current (AMP)	Power Consumption (WATTS)	Speed (RPM)	Air Flow (CFM)	Static Pressure (Inch-H <sub>2</sub> O)	Noise (dBA)	Weight (g)
SP100A	1123XSL.GN	◎	115	50/60	0.26/0.24	22/20	2700/3100	95/115	0.33/0.38	44/49	550
SP100A	1123XST.GN	◎	115	50/60	0.26/0.24	22/20	2700/3100	95/115	0.33/0.38	44/49	550
SP101A	1123HSL.GN	◎	115	50/60	0.21/0.18	20/18	2550/2900	85/105	0.25/0.30	43/48	550
SP101A	1123HST.GN	◎	115	50/60	0.21/0.18	20/18	2550/2900	85/105	0.25/0.30	43/48	550
SP102A	1123MSL.GN	◎	115	50/60	0.17/0.16	15/15	2400/2600	78/84	0.14/0.21	33/38	550
SP102A	1123MST.GN	◎	115	50/60	0.17/0.16	15/15	2400/2600	78/84	0.14/0.21	33/38	550
SP103A	1123LSL.GN	◎	115	50/60	0.11/0.13	11/11	2200/2000	76/70	0.12/0.08	38/36	550
SP103A	1123LST.GN	◎	115	50/60	0.11/0.13	11/11	2200/2000	76/70	0.12/0.08	38/36	550
SP100A	1123XBL.GN	○	115	50/60	0.26/0.24	22/20	2850/3150	97/117	0.34/0.39	45/50	550
SP100A	1123XBT.GN	○	115	50/60	0.26/0.24	22/20	2850/3150	97/117	0.34/0.39	45/50	550
SP101A	1123HBL.GN	○	115	50/60	0.21/0.18	20/18	2750/3050	87/107	0.26/0.32	45/50	550
SP101A	1123HBT.GN	○	115	50/60	0.21/0.18	20/18	2750/3050	87/107	0.26/0.32	45/50	550
SP102A	1123MBL.GN	○	115	50/60	0.17/0.16	16/15	2500/2700	80/88	0.15/0.22	35/40	550
SP102A	1123MBT.GN	○	115	50/60	0.17/0.16	16/15	2500/2700	80/88	0.15/0.22	35/40	550
SP103A	1123LBL.GN	○	115	50/60	0.13/0.11	11/11	2150/2300	72/78	0.09/0.13	37/39	550
SP103A	1123LBT.GN	○	115	50/60	0.13/0.11	11/11	2150/2300	72/78	0.09/0.13	37/39	550

Frame : Aluminum alloy

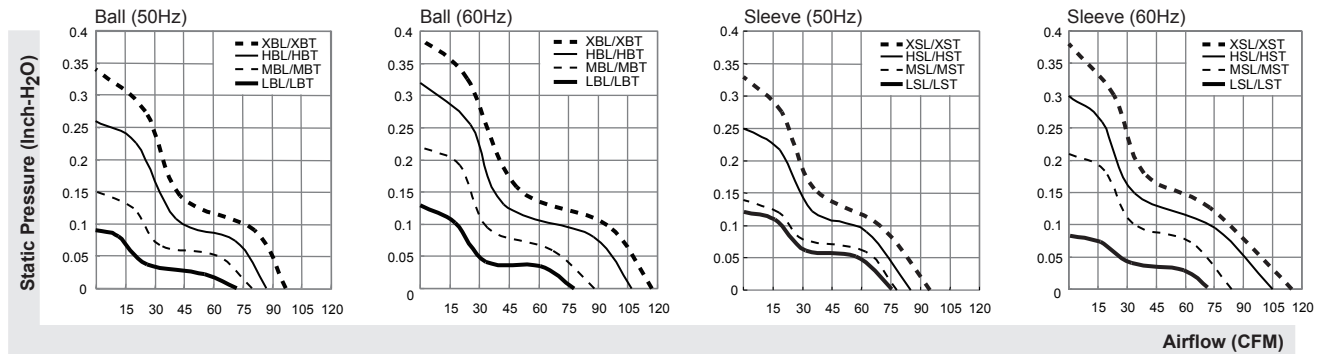

UNITS:mm

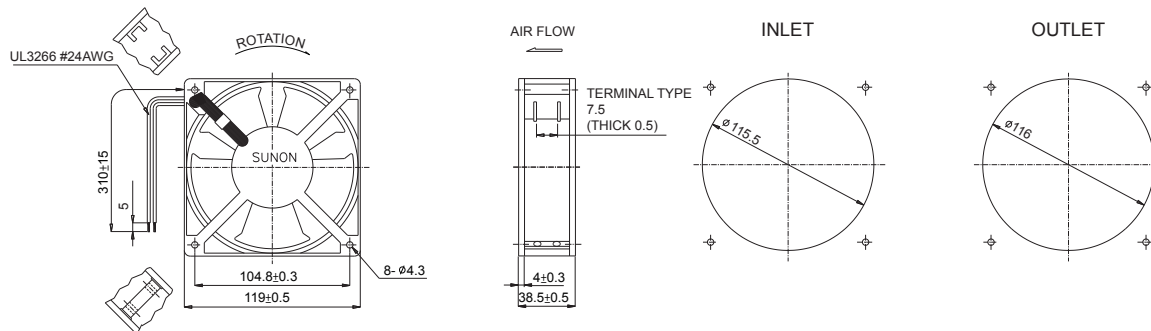

\*All model could be customized on voltage or any other requirements to fit your need.

\*Specifications subject to change without notice. Please Visit SUNON web site at <http://www.sunon.com> for update information.

## 70-117CFM



Model	P/N	Bearing ● VAPO ○ BALL ◎ Sleeve	Rating Voltage (VAC)	Freq. (Hz)	Power Current (AMP)	Power Consumption (WATTS)	Speed (RPM)	Air Flow (CFM)	Static Pressure (Inch-H <sub>2</sub> O)	Noise (dBA)	Weight (g)
DP200A	2123XSL.GN	◎	220-240	50/60	0.14/0.12	22/21	2700/3100	95/115	0.33/0.38	44/49	550
DP200A	2123XST.GN	◎	220-240	50/60	0.14/0.12	22/21	2700/3100	95/115	0.33/0.38	44/49	550
DP201A	2123HSL.GN	◎	220-240	50/60	0.125/0.11	20/19	2550/2900	85/105	0.25/0.30	43/48	550
DP201A	2123HST.GN	◎	220-240	50/60	0.125/0.11	20/19	2550/2900	85/105	0.25/0.30	43/48	550
DP202A	2123MSL.GN	◎	220-240	50/60	0.09/0.08	16/15	2300/2500	78/84	0.14/0.21	33/38	550
DP202A	2123MST.GN	◎	220-240	50/60	0.09/0.08	16/15	2300/2500	78/84	0.14/0.21	33/38	550
DP203A	2123LSL.GN	◎	220-240	50/60	0.06/0.05	11/10	2000/1800	70/63	0.08/0.07	36/32	550
DP203A	2123LST.GN	◎	220-240	50/60	0.06/0.05	11/10	2000/1800	70/63	0.08/0.07	36/32	550
DP200A	2123XBL.GN	○	220-240	50/60	0.14/0.12	22/21	2850/3150	97/117	0.34/0.39	45/50	550
DP200A	2123XBT.GN	○	220-240	50/60	0.14/0.12	22/21	2850/3150	97/117	0.34/0.39	45/50	550
DP201A	2123HBL.GN	○	220-240	50/60	0.125/0.11	20/19	2750/3050	87/107	0.26/0.32	45/50	550
DP201A	2123HBT.GN	○	220-240	50/60	0.125/0.11	20/19	2750/3050	87/107	0.26/0.32	45/50	550
DP202A	2123MBL.GN	○	220-240	50/60	0.09/0.08	16/15	2400/2600	78/84	0.14/0.21	34/39	550
DP202A	2123MBT.GN	○	220-240	50/60	0.09/0.08	16/15	2400/2600	78/84	0.14/0.21	34/39	550
DP203A	2123LBL.GN	○	220-240	50/60	0.06/0.05	10/10	2150/2300	72/78	0.09/0.13	37/39	550
DP203A	2123LBT.GN	○	220-240	50/60	0.06/0.05	10/10	2150/2300	72/78	0.09/0.13	37/39	550

Frame : Aluminum alloy

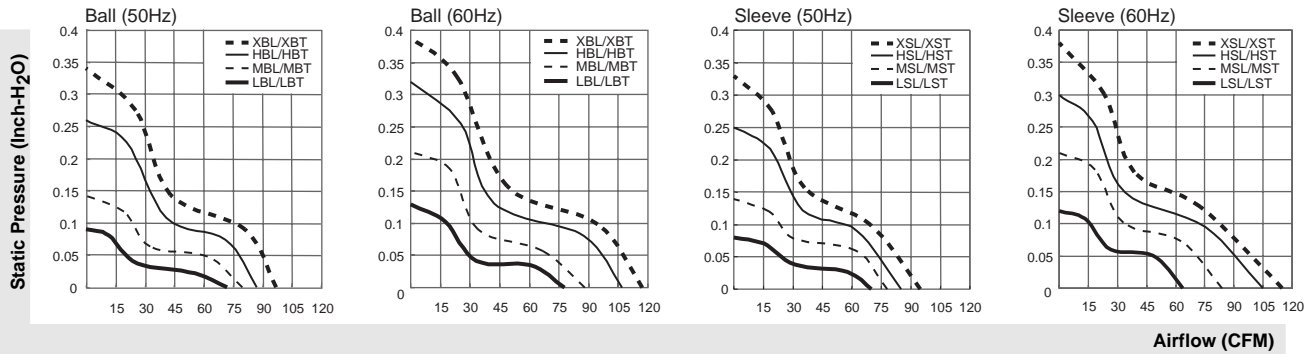

UNITS:mm

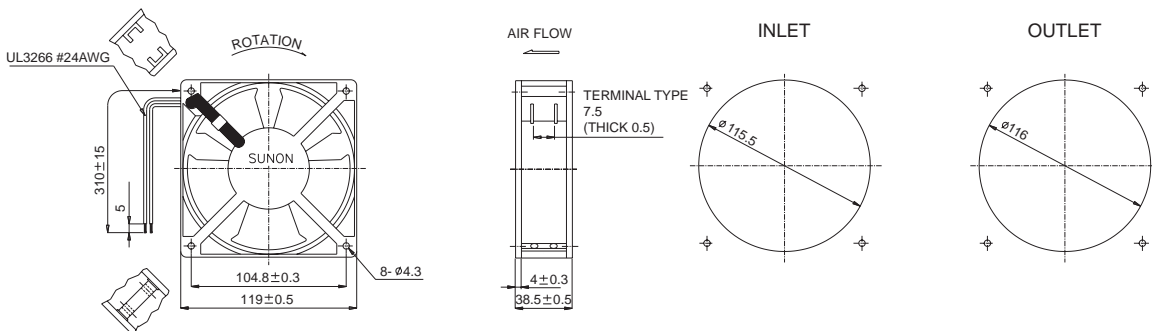

\*All model could be customized on voltage or any other requirements to fit your need.

\*Specifications subject to change without notice. Please Visit SUNON web site at <http://www.sunon.com> for update information.



## 85-100 CFM



Model	P/N	Bearing ● VAPO ○ BALL ⊙ Sleeve	Rating Voltage (VAC)	Freq. (Hz)	Power Current (AMP)	Power Consumption (WATTS)	Speed (RPM)	Air Flow (CFM)	Static Pressure (Inch-H <sub>2</sub> O)	Noise (dBA)	Weight (g)
SP109WR	1123HST.GN	⊙	115	50/60	0.25/0.22	22/20	2500/2900	85/100	0.28/0.35	41/47	465
SP109WR	1123HSL.GN	⊙	115	50/60	0.25/0.22	22/20	2500/2900	85/100	0.28/0.35	41/47	465
SP109WR	1123HBT.GN	○	115	50/60	0.25/0.22	22/20	2500/2900	85/100	0.25/0.30	42/48	465
SP109WR	1123HBL.GN	○	115	50/60	0.25/0.22	22/20	2500/2900	85/100	0.25/0.30	42/48	465
DP209WR	2123HST.GN	⊙	220-240	50/60	0.13/0.12	22/21	2500/2900	85/100	0.28/0.35	41/47	465
DP209WR	2123HSL.GN	⊙	220-240	50/60	0.13/0.12	22/21	2500/2900	85/100	0.28/0.35	41/47	465
DP209WR	2123HBT.GN	○	220-240	50/60	0.13/0.12	22/21	2500/2900	85/100	0.25/0.30	42/48	465
DP209WR	2123HBL.GN	○	220-240	50/60	0.13/0.12	22/21	2500/2900	85/100	0.25/0.30	42/48	465

Frame : PBT Plastic

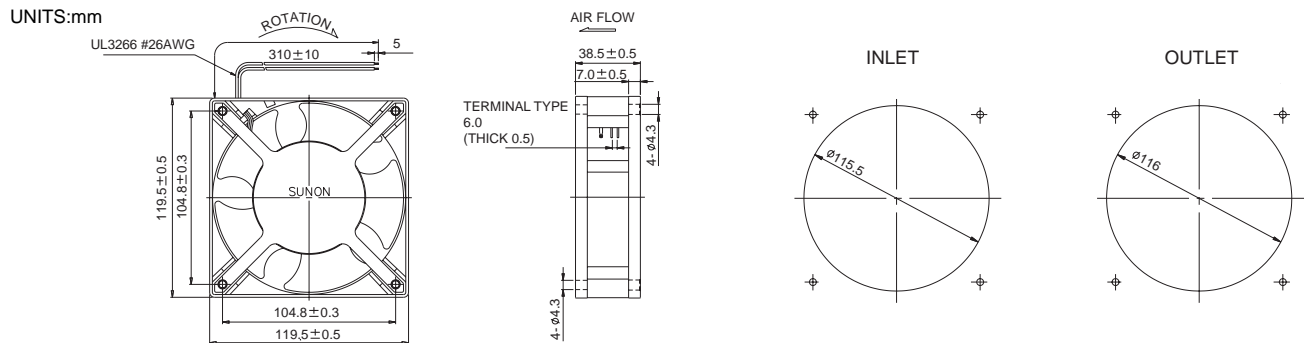
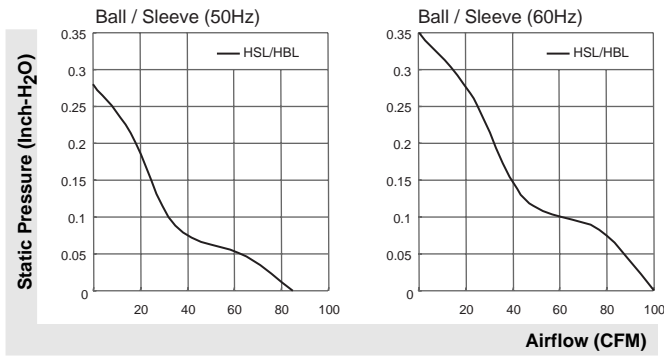

\*All model could be customized on voltage or any other requirements to fit your need.

\*Specifications subject to change without notice. Please Visit SUNON web site at <http://www.sunon.com> for update information.

NEW



## 95-117 CFM

Model	P/N	Bearing ● VAPO ○ BALL ⊙ Sleeve	Rating Voltage (VAC)	Freq. (Hz)	Power Current (AMP)	Power Consumption (WATTS)	Speed (RPM)	Air Flow (CFM)	Static Pressure (Inch-H <sub>2</sub> O)	Noise (dBA)	Weight (g)
A1123-HST	GN	⊙	115	50/60	0.28/0.25	23/20	2700/3100	95/115	0.33/0.38	44/49	525
A1123-HSL	GN	⊙	115	50/60	0.28/0.25	23/20	2700/3100	95/115	0.33/0.38	44/49	525
A1123-HBT	GN	○	115	50/60	0.28/0.25	23/20	2700/3100	97/117	0.34/0.39	45/50	525
A1123-HBL	GN	○	115	50/60	0.28/0.25	23/20	2700/3100	97/117	0.34/0.39	45/50	525
A2123-HST	GN	⊙	220-240	50/60	0.14/0.12	23/20	2700/3100	95/115	0.33/0.38	44/49	525
A2123-HSL	GN	⊙	220-240	50/60	0.14/0.12	23/20	2700/3100	95/115	0.33/0.38	44/49	525
A2123-HBT	GN	○	220-240	50/60	0.14/0.12	23/20	2700/3100	97/117	0.34/0.39	45/50	525
A2123-HBL	GN	○	220-240	50/60	0.14/0.12	23/20	2700/3100	97/117	0.34/0.39	45/50	525

Frame : Aluminum alloy

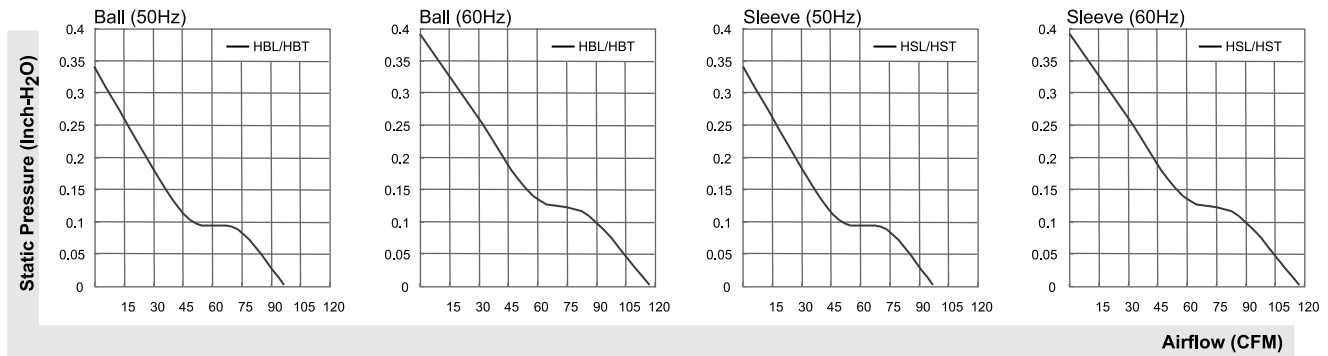

UNITS:mm

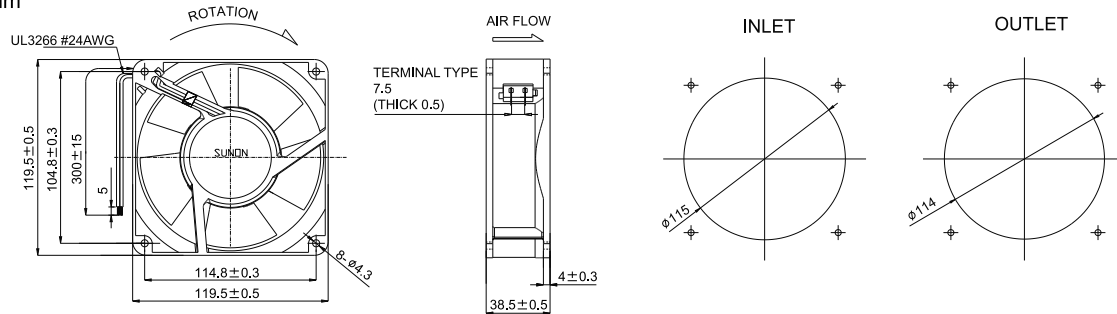

\*All model could be customized on voltage or any other requirements to fit your need.

\*Specifications subject to change without notice. Please Visit SUNON web site at <http://www.sunon.com> for update information.

## Dual AC Voltage 95-115 CFM



Model	P/N	Bearing	Rating Voltage (VAC)	Freq. (Hz)	Power Current (AMP)	Power Consumption (WATTS)	Speed (RPM)	Air Flow (CFM)	Static Pressure (Inch-H <sub>2</sub> O)	Noise (dBA)	Weight (g)
SF1212AD	SL.GN	● VAPO ○ BALL ⊙ Sleeve	115 220-240	50/60	0.27/0.24 0.13/0.12	21.5/19 19.5/19	2700/3100	95/115	0.33/0.38	44/49	550
SF1212AD	BL.GN	○	115 220-240	50/60	0.27/0.24 0.13/0.12	21.5/19 19.5/19	2700/3100	95/115	0.33/0.38	44/49	550

Frame : Aluminum alloy

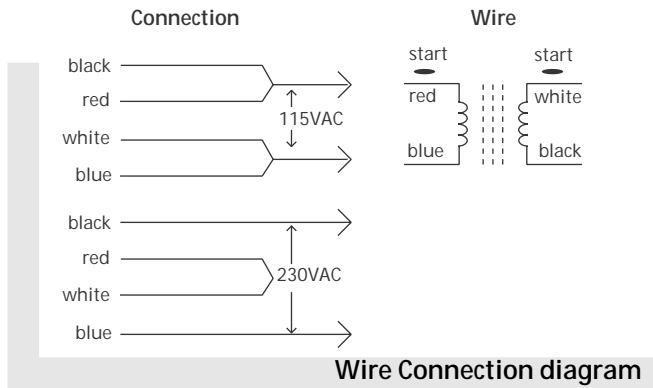
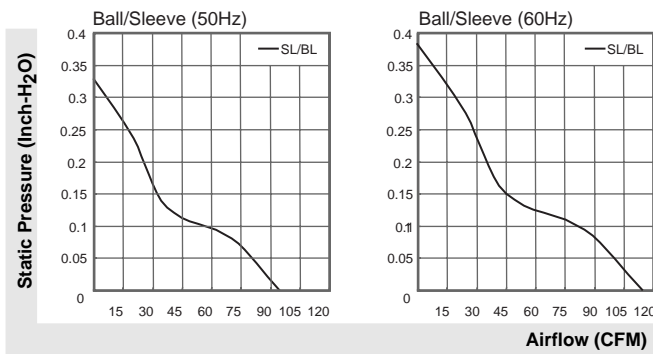

UNITS:mm

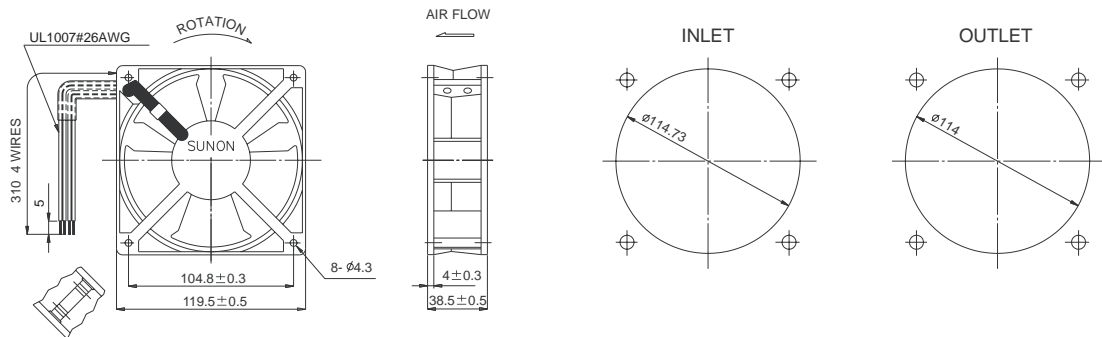

\*All model could be customized on voltage or any other requirements to fit your need.  
\*Specifications subject to change without notice. Please Visit SUNON web site at <http://www.sunon.com> for update information.

## 180-200 CFM

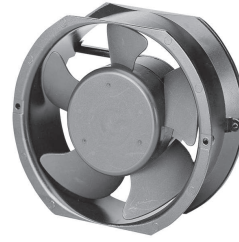

Model	P/N	Bearing	Rating Voltage (VAC)	Freq. (Hz)	Power Current (AMP)	Power Consumption (WATTS)	Speed (RPM)	Air Flow (CFM)	Static Pressure (Inch-H <sub>2</sub> O)	Noise (dBA)	Weight (g)
A1175-HBL	T.GN	○ BALL	115	50/60	0.59/0.48	39/36	2650/2950	180/200	0.48/0.38	52/55	957
A1175-HBT	T.GN	○ BALL	115	50/60	0.59/0.48	39/36	2650/2950	180/200	0.48/0.38	52/55	957
A2175-HBL	T.GN	○ BALL	220-240	50/60	0.28/0.24	39/36	2650/2950	180/200	0.48/0.38	52/55	957
A2175-HBT	T.GN	○ BALL	220-240	50/60	0.28/0.24	39/36	2650/2950	180/200	0.48/0.38	52/55	957

Frame : Aluminum alloy

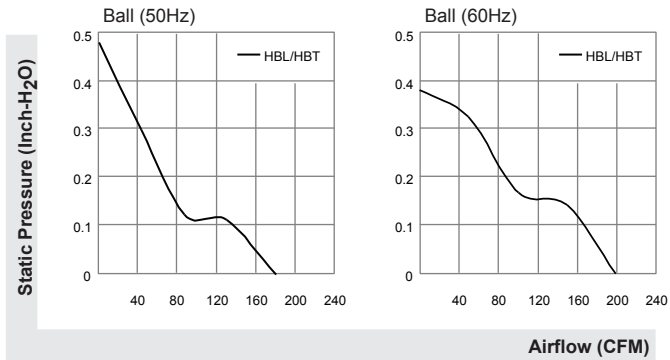

UNITS:mm

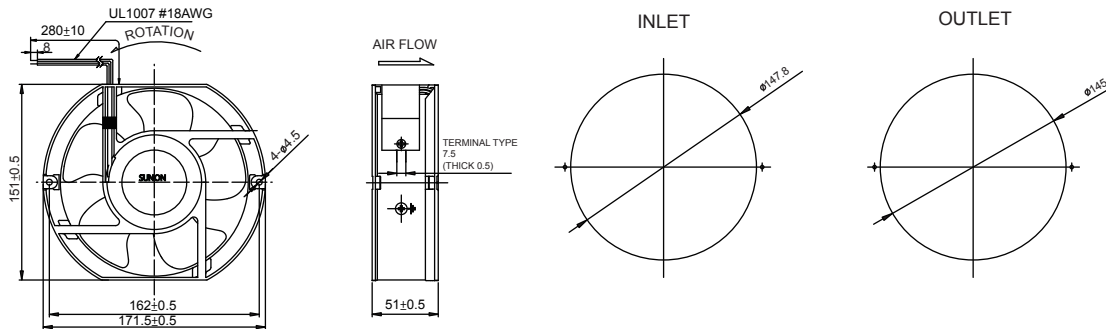

\*All model could be customized on voltage or any other requirements to fit your need.

\*Specifications subject to change without notice. Please Visit SUNON web site at <http://www.sunon.com> for update information.

# Alveolate Motor

## 203-239 CFM



Model	P/N	Bearing	Rating Voltage (VAC)	Freq. (Hz)	Power Current (AMP)	Power Consumption (WATTS)	Speed (RPM)	Air Flow (CFM)	Static Pressure (Inch-H <sub>2</sub> O)	Noise (dBA)	Weight (g)
A1175-HBL	TC.GN	○ BALL	115	50/60	0.22/0.23	25/27	2800/3200	203/239	0.62/0.69	51/58	908
A1175-HBT	TC.GN	○ BALL	115	50/60	0.22/0.23	25/27	2800/3200	203/239	0.62/0.69	51/58	908
A2175-HBL	TC.GN	○ STEEVE	220-240	50/60	0.11/0.11	25/26	2800/3200	203/239	0.62/0.69	51/58	908
A2175-HBT	TC.GN	○ STEEVE	220-240	50/60	0.11/0.11	25/26	2800/3200	203/239	0.62/0.69	51/58	908

Frame : Aluminum alloy

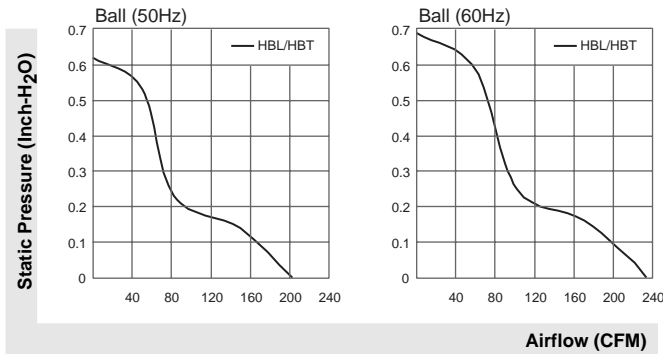

UNITS:mm

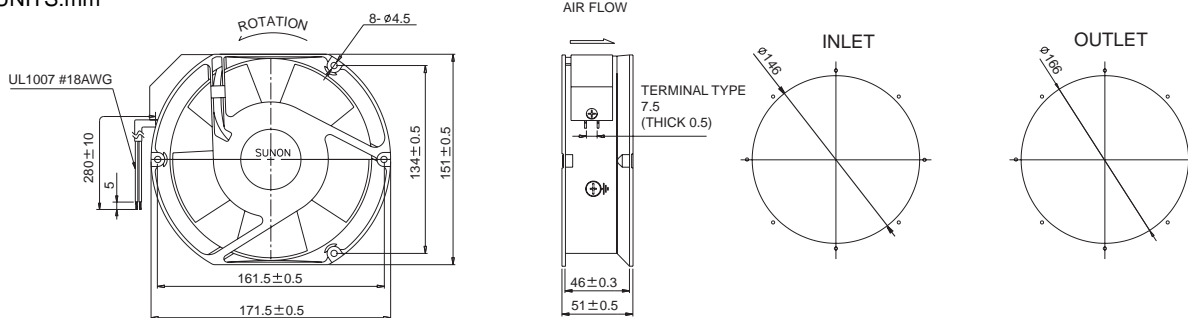

\*All model could be customized on voltage or any other requirements to fit your need.  
 \*Specifications subject to change without notice. Please Visit SUNON web site at <http://www.sunon.com> for update information.

# Alveolate Motor

## 203-239 CFM



Model	P/N	Bearing	Rating Voltage (VAC)	Freq. (Hz)	Power Current (AMP)	Power Consumption (WATTS)	Speed (RPM)	Air Flow (CFM)	Static Pressure (Inch-H <sub>2</sub> O)	Noise (dBA)	Weight (g)
A1175-HBL	TC.R.GN	○ BALL	115	50/60	0.22/0.23	25/27	2800/3200	203/239	0.62/0.69	51/58	908
A1175-HBT	TC.R.GN	○ BALL	115	50/60	0.22/0.23	25/27	2800/3200	203/239	0.62/0.69	51/58	908
A2175-HBL	TC.R.GN	○ BALL	220-240	50/60	0.11/0.11	25/26	2800/3200	203/239	0.62/0.69	51/58	908
A2175-HBT	TC.R.GN	○ BALL	220-240	50/60	0.11/0.11	25/26	2800/3200	203/239	0.62/0.69	51/58	908

Frame : Aluminum alloy

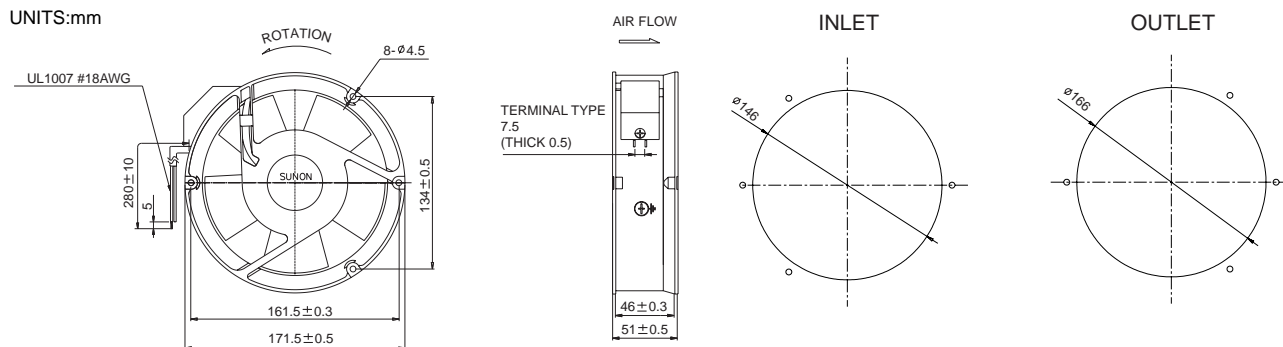
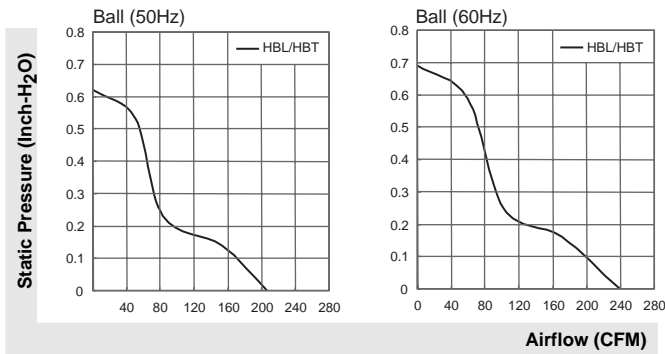

\*All model could be customized on voltage or any other requirements to fit your need.  
 \*Specifications subject to change without notice. Please Visit SUNON web site at <http://www.sunon.com> for update information.

Alveolate Motor

315-335CFM



Model	P/N	Bearing ● VAPO ○ BALL ⊙ Sleeve	Rating Voltage (VAC)	Freq. (Hz)	Power Current (AMP)	Power Consumption (WATTS)	Speed (RPM)	Air Flow (CFM)	Static Pressure (Inch-H <sub>2</sub> O)	Noise (dBA)	Weight (g)
A1179-HBT	TC.GN	○	115	50/60	0.25/0.27	24/30	2800/3250	315/335	0.65/0.8	62/66	1960
A1179-HBL	TC.GN	○	115	50/60	0.25/0.27	24/30	2800/3250	315/335	0.65/0.8	62/66	1960
A2179-HBT	TC.GN	○	220-240	50/60	0.11/0.15	23/30	2800/3250	315/335	0.65/0.8	62/66	1960
A2179-HBL	TC.GN	○	220-240	50/60	0.11/0.15	23/30	2800/3250	315/335	0.65/0.8	62/66	1960

Frame : Aluminum alloy

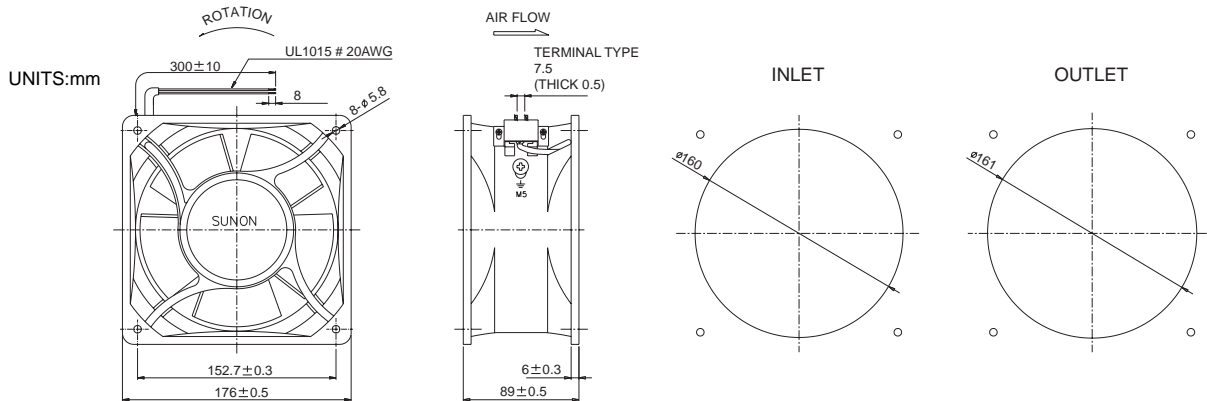
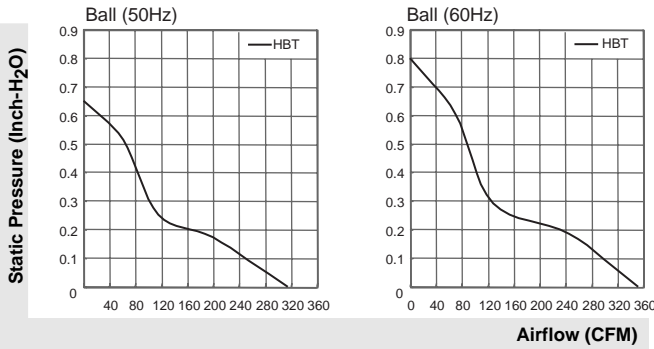

\*All model could be customized on voltage or any other requirements to fit your need.  
 \*Specifications subject to change without notice. Please Visit SUNON web site at <http://www.sunon.com> for update information.

## Alveolate Motor 425-870 CFM

**NEW**



Model	P/N	Bearing ● VAPO ○ BALL ⊙ Sleeve	Rating Voltage (VAC)	Freq. (Hz)	Power Current (AMP)	Power Consumption (WATTS)	Speed (RPM)	Air Flow (CFM)	Static Pressure (Inch-H <sub>2</sub> O)	Noise (dBA)	Weight (g)
A1259-MBL	TC.N.GN	○	115	50/60	0.23/0.23	20/23	1400/1600	425/500	0.27/0.31	50/52	2300
A1259-MBT	TC.N.GN	○	115	50/60	0.23/0.23	20/23	1400/1600	425/500	0.27/0.31	50/52	2300
A1259-HBL	TC.N.GN	○	115	50/60	0.60/0.65	63/72	2100/1900	650/585	0.35/0.31	62/60	2300
A1259-HBT	TC.N.GN	○	115	50/60	0.60/0.65	63/72	2100/1900	650/585	0.35/0.31	62/60	2300
A1259-XBL	TC.N.GN	○	115	50/60	0.83/1.10	88/120	2600/2900	800/870	0.76/0.62	68/70	2400
A1259-XBT	TC.N.GN	○	115	50/60	0.83/1.10	88/120	2600/2900	800/870	0.76/0.62	68/70	2400
A2259-MBL	TC.N.GN	○	220-240	50/60	0.15/0.13	63/72	1400/1600	425/500	0.27/0.31	50/52	2300
A2259-MBT	TC.N.GN	○	220-240	50/60	0.15/0.13	63/72	1400/1600	425/500	0.27/0.31	50/52	2300
A2259-HBL	TC.N.GN	○	220-240	50/60	0.24/0.27	56/61	2100/1900	650/585	0.35/0.31	62/60	2300
A2259-HBT	TC.N.GN	○	220-240	50/60	0.24/0.27	56/61	2100/1900	650/585	0.35/0.31	62/60	2300

Frame : Aluminum alloy

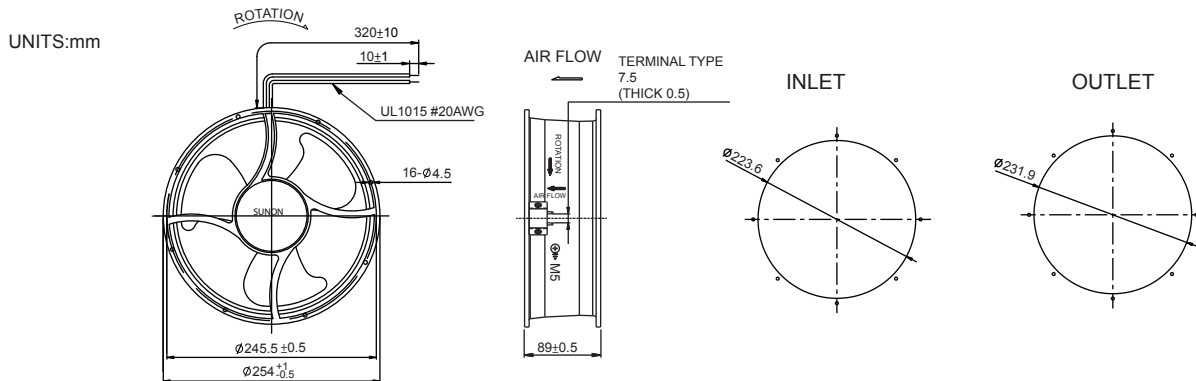
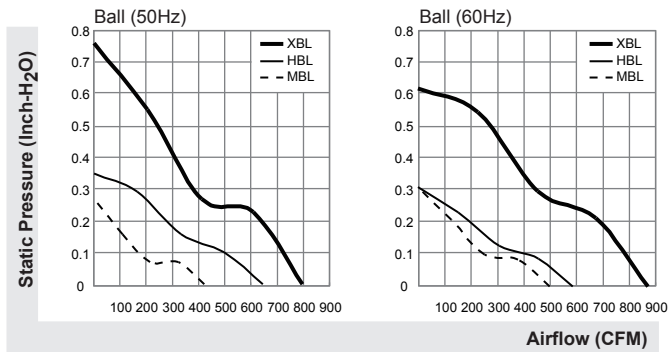

\*All model could be customized on voltage or any other requirements to fit your need.

\*Specifications subject to change without notice. Please Visit SUNON web site at <http://www.sunon.com> for update information.



## 20-22 CFM



Model	P/N	Bearing	Rating Voltage (VAC)	Freq. (Hz)	Power Current (AMP)	Power Consumption (WATTS)	Speed (RPM)	Air Flow (CFM)	Static Pressure (Inch-H <sub>2</sub> O)	Noise (dBA)	Weight (g)
AB1123-HST	GN	● Vapo	115	50/60	0.25/0.21	20/18	2600/2900	20/22	0.32/0.46	48/50	678
AB1123-HSL	GN	○ BALL	115	50/60	0.25/0.21	20/18	2600/2900	20/22	0.32/0.46	48/50	678
AB1123-HBT	GN	○ SLEEVE	115	50/60	0.25/0.21	20/18	2600/2900	20/22	0.32/0.46	48/50	678
AB1123-HBL	GN	○ BALL	115	50/60	0.25/0.21	20/18	2600/2900	20/22	0.32/0.46	48/50	678
AB2123-HST	GN	● Vapo	220-240	50/60	0.14/0.11	20/18	2600/2900	20/22	0.32/0.46	48/50	678
AB2123-HSL	GN	○ BALL	220-240	50/60	0.14/0.11	20/18	2600/2900	20/22	0.32/0.46	48/50	678
AB2123-HBT	GN	○ SLEEVE	220-240	50/60	0.14/0.11	20/18	2600/2900	20/22	0.32/0.46	48/50	678
AB2123-HBL	GN	○ BALL	220-240	50/60	0.14/0.11	20/18	2600/2900	20/22	0.32/0.46	48/50	678

Frame : Aluminum alloy

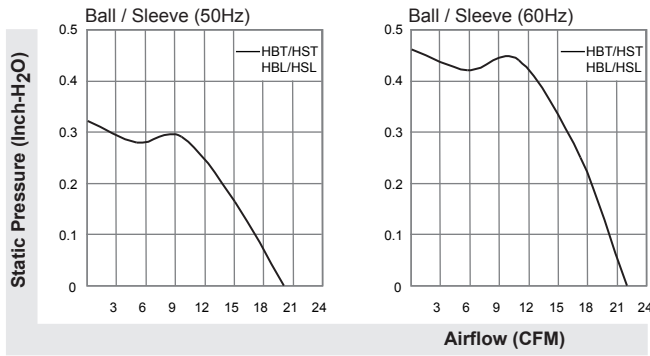

UNITS:mm

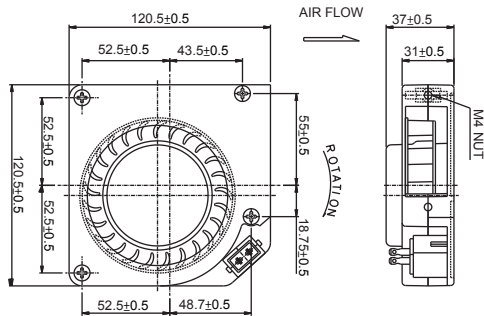

\*All model could be customized on voltage or any other requirements to fit your need.

\*Specifications subject to change without notice. Please Visit SUNON web site at <http://www.sunon.com> for update information.

Headquarters:

**Sunonwealth Electric Machine Industry Co., Ltd.**

No. 30, Lane 296, Hsin Ya Road, Chien-Chen District, Kaohsiung, Taiwan  
TEL : +886-7-8135888  
FAX : +886-7-8230505/8230606/8231010  
URL: <http://www.sunon.com>  
E-mail: [sunon@email.sunon.com.tw](mailto:sunon@email.sunon.com.tw)

**Sunon Inc. (U.S.A.)**

1075 West Lambert Road Suite A, Brea, California 92821, U.S.A  
TEL : +1-714-255-0208  
FAX : +1-714-255-0802  
URL : <http://www.sunonusa.com>  
E-mail : [info@sunon.com](mailto:info@sunon.com)

**Sunon SAS (Europe)**

Parc Medis, 66, Ave Des Pepinieres 94832, Fresnes Cedex-France  
TEL : +33-1-46154515  
FAX : +33-1-46154510  
URL: <http://www.sunoneurope.com>  
E-mail : [info@sunoneurope.com](mailto:info@sunoneurope.com)

**Sunon Corporation (Japan)**

Stork Minami Otsuka 4Fl.33-1, 2 Chome,  
Minami Otsuka Toshimaku, Tokyo, Japan 170-0005  
TEL : +81-3-5395-3069  
FAX: +81-3-5395-3080  
URL: <http://www.sunon.co.jp>  
E-mail : [info@sunon.co.jp](mailto:info@sunon.co.jp)

**Sunon Technologies Pte Ltd. (Singapore)**

10 Toh Guan Road, #03-08 TT International Tradepark, Singapore 608838  
TEL : +65-6795-0300  
FAX : +65-6795-0600  
E-mail : [info@sunon.com.sg](mailto:info@sunon.com.sg)

**Sunonwealth Electric Machine Industry (HK) Ltd. (Hong Kong)**

1906 Nan Fung Center, 264 Castle Peak Road, Tsuen Wan, Hong Kong  
TEL : + 852-24-111-388  
FAX : + 852-24-050-707  
E-mail : [info@sunon.com.hk](mailto:info@sunon.com.hk)

**Sunon Shanghai Office (Shanghai, China)**

TEL : +86-021-54070116  
FAX : +86-021-54070116  
URL: <http://www.sunon.com.cn>

**Sunon Shen Zhen Office (Shen Zhen, China)**

TEL : +86-755-26880688  
FAX : +86-755-26880288  
E-mail : [info@sunon.com.cn](mailto:info@sunon.com.cn)

**Sunon Guangzhou Office (Guangzhou, China)**

TEL : +86-20-87788928  
FAX : +86-20-87786786

## X-ON Electronics

Largest Supplier of Electrical and Electronic Components

*Click to view similar products for [sunon manufacturer](#):*

Other Similar products are found below :

[MB50151V2-000U-A99](#) [3113HQ/MC40101V2-Q00U-S99](#) [UF3A3-700](#) [UB3H3-500](#) [PMB2475PNB3-AY.\(2\).GN](#) [KD1208PHB1.13.\(2\).GN](#)  
[KD1204PKB3 \(2\).GN](#) [GB1205PKV2-8AY.F.GN](#) [EE60251B1-000U-C99](#) [3236HQ/PF40281B1-D17U-S99](#) [A2175HBT-TC.R.GN](#) [B2-10](#)  
[SM203-13002](#) [PE80254V1-000U-A99](#) [GE80252B1-000U-AC9](#) [PF92251V1-1000U-A99](#) [ME80201V2-000U-A99](#) [PE92252B1-000C-AB9](#)  
[MC30101V2-000C-A99\(165mm\)](#) [MF20100V4-1Q04C-G99](#) [PE92254B2-000C-F99](#) [MC30150V1-000C-A99](#) [PE80252B1-000C-AB9](#)  
[MF20060V3-1Q07A-G99](#) [MC25100V2-000C-G99](#) [PMD2412PMB1-A\(2\).R.GN.I55](#) [AB1123-HST.GN](#) [PF80381BX-000U-A99](#) [MF25100V1-](#)  
[1000U-A99](#) [PF80251V1-1000U-F99](#) [PF92381B1-000U-A99](#) [VF40281BX-000U-A9H](#) [40HVH120M](#) [LA004-024A83DY](#) [SM203-14001Y](#)  
[MF80251V1-1000U-G99](#) [EE60251B2-000U-999](#) [SM203-13004Y](#) [SM205-13001](#) [F92-B](#) [FG-8/45](#) [LA004-011A99DN](#) [SF11592A-](#)  
[1092HSL.GN](#) [CF4113HBL-000U-ABD](#) [SF23092A-2092MBL.GN](#) [MF20100V1-1000U-A99](#) [DP203A-2123LBL.\(5\).GN](#) [PF40281B3-000U-](#)  
[A99](#) [LM310-001A99DN](#) [KD2406PKB2.\(2\).GN](#)