

# MagLev<sup>®</sup> Fan & Blower

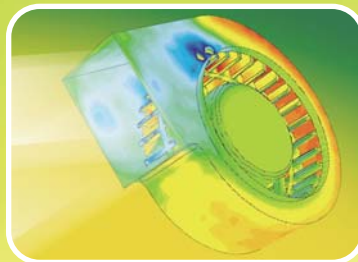

\*All products are **RoHS** compliance.



**SUNON<sup>®</sup>**

# Contents

Page				
Fan 3rd Wire Signal / Safety & Certification				p02
Fan Model Numbering System / Connector recommendation				p03
Size (mm)	MagLev DC Fan	Power Motor Fan	MagLev DC Blower	MagLev AC Fan
17x17x8	p05			
20x20x8	p06			
20x20x10	p07			
25x25x6	p08			
25x25x10	p09			
25x25x15	p10			
30x30x6	p11			
30x30x10	p12			
30x30x15	p13			
35x35x6	p14			
35x35x10	p15			
38x38x20		p35		
38x38x28		p36		
40x40x6	p16			
40x40x10	p17			
40x40x20	p18			
40x40x24		p37		
40x40x28		p38		
40x40x56		p39		
45x45x10	p19			
50x50x10	p20			
50x50x15	p21		p53	
50x50x20			p54	
60x60x10	p22			
60x60x15	p23		p55	
60x60x20	p24	p40		
60x60x25	p25	p41		p61
60x60x38		p42		
70x70x10	p26			
70x70x15	p27			
70x70x20	p28	p43		
70x70x25	p29	p44		p62
75x75x30			p56	
80x80x20	p30	p45		
80x80x25	p31	p46		p63
80x80x38		p47		
92x92x25	p32	p48		p64
92x92x38		p49		
97x94x33			p57	
120x120x25		p50		
120x120x32			p58	
120x120x38	p33	p51		

# Fan 3rd Wire Signal

Fan with switching driving circuit designed for rpm measurement:

These fan motors have three lead wires:

+:Red,

-:Black,

output signal for 3rd wire:

F Type : Yellow

R Type : White

## ● R Type (Rotation Detector)

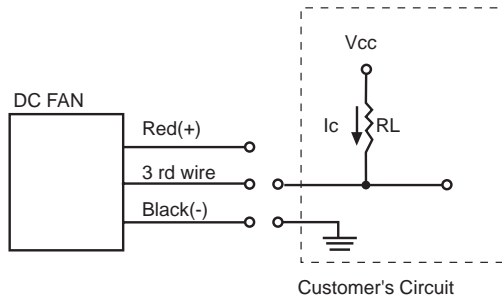
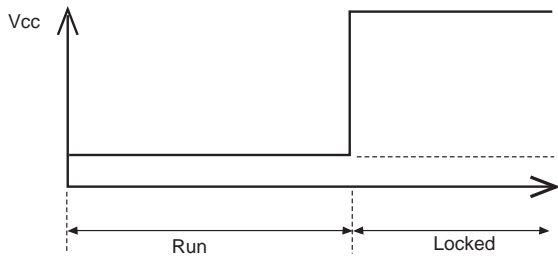

## ● F Type (Frequency Generator)

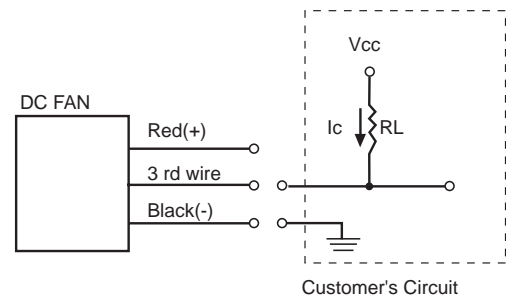
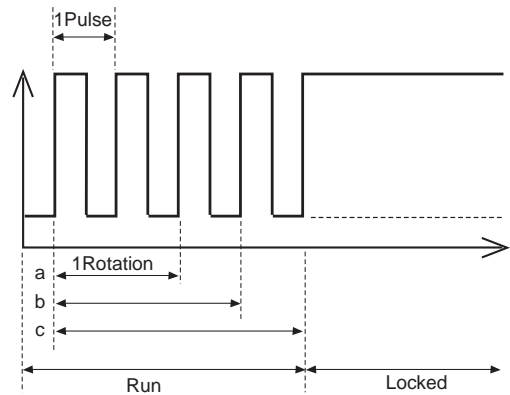

The relationship between rotation & output pulses signal from 3rd wire are as follows:

(a) 1 Rotation=2 Pulses(4 poles' motor)

(b) 1 Rotation=3 Pulses(6 poles' motor)

(c) 1 Rotation=4 Pulses(8 poles' motor)

Notice:

For 8 poles' motor: normally,

1Rotation=4 pulses, if frequency divided circuit is implemented in this motor then

1Rotation=2 pulses.

## Safety



# DC Fan and Blower Model Numbering System

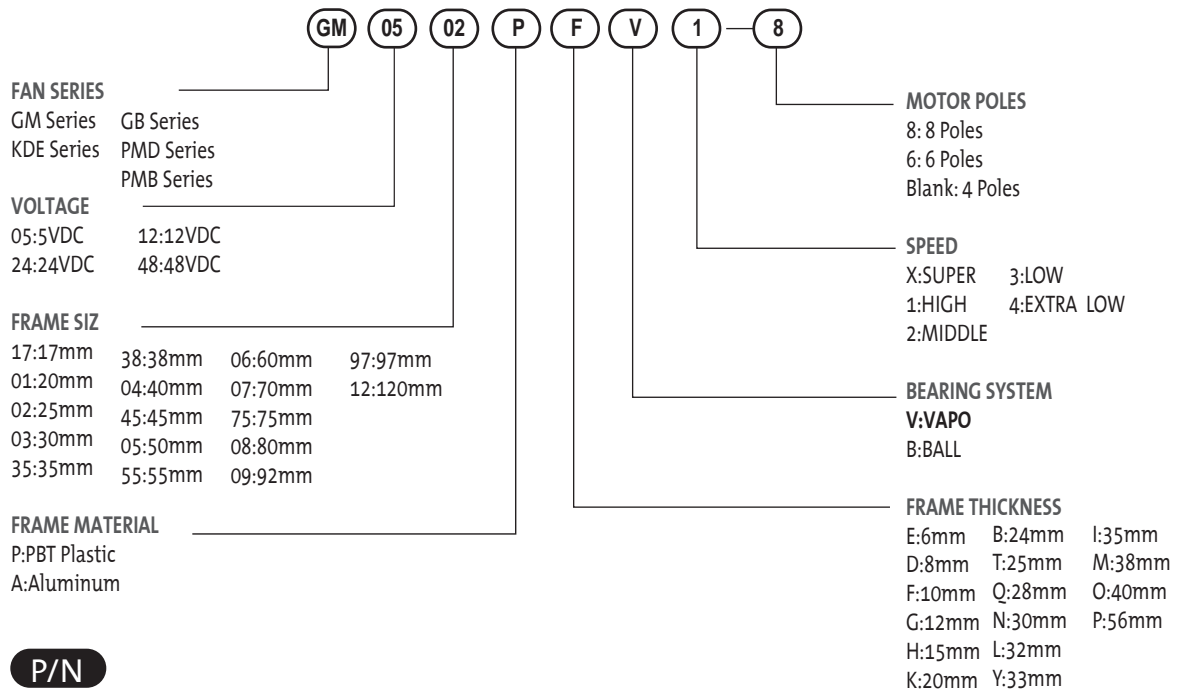

## P/N

Example: KDE1208PTV1 P/N:13.MS.A.GN

- 11/13 Motor model
- MS MagLev Design
- (2) Two ball bearing
- G Big hub
- (9) 9 Blades
- N Smaller hub
- A Auto restart
- F 3rd wire with frequency generation waveform
- R 3rd wire with rotation detector waveform
- U Upgrade
- GN RoHS compliance

## Sunon Connector recommendation

Connector pitch	Manufacturer	Housing	Terminal
1.25mm	HIROSE	DF13-2S-1.25C	DF13-2630SCF
	MOLEX	51021-0300	50058-8200
1.5mm	JST	ZHR-2	SZH-002T-P0.5 or SZH-003T-P0.5
2.0mm	JST	PHR-2	SPH-002T-P0.5S
2.54mm	ECI	2510-02	2511-P
	Molex	50-57-9405	16-02-0069(70058-0004) or 16-02-0082(70058-0006)
	Molex	2695-02RP	2759T(39-00-0372)
	Molex	2695-03RP	2759T(39-00-0372)
	Molex	6471-021	4809-C-P914
2.50mm	Molex	6471-031	4809-C-P914
	JAM	SC25-02HG	725462-2MA
	JST	SMR-02V-B	SYM-001T-P0.6
	JST	XHP-2	SXH-001T-0.6
	JST	EHR-2(H28J-2)	SEH-001T-P0.6
	JST	SMP-02V-BC	SHF-001T-0.8BS
	JWT	A2502H02-2P	A2502TOP-2
	JWT	A2502H02-3P	A2502TOP-2
	Molex	5051-02	2759T(39-00-0372)
Molex	5264-02	5263PBT(08-70-1039)	



MagLev Green Motor Fan  
 MagLev Motor Fan



# 17x17x8 mm

# SUNON

## MagLev Green Motor Fan

## 0.7~0.9 CFM



Model	P/N	Bearing ● VAPO ⊙ 2BALL	Rating Voltage (VDC)	Power Current (AMP)	Power Consumption (WATTS)	Speed (RPM)	Air Flow (CFM)	Static Pressure (Inch-H <sub>2</sub> O)	Noise (dBA)	Weight (g)
GM0517PDV1-8	GN	●	5	0.16	0.8	20000	0.9	0.28	25	4.36
GM0517PDV2-8	GN	●	5	0.11	0.6	15000	0.7	0.17	16	4.36

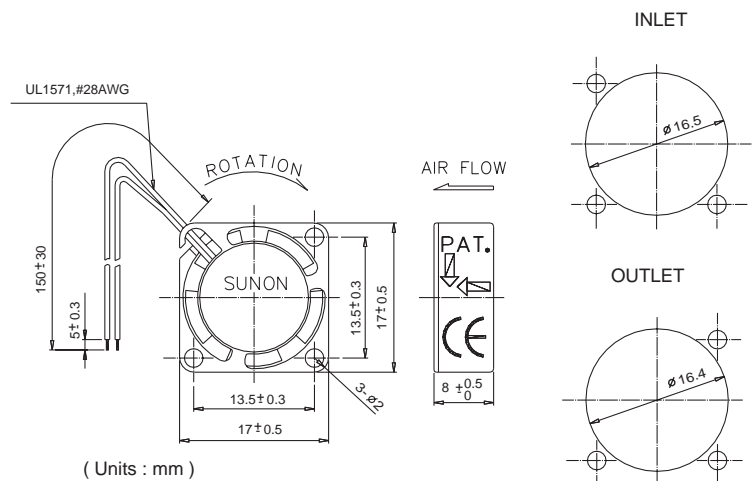
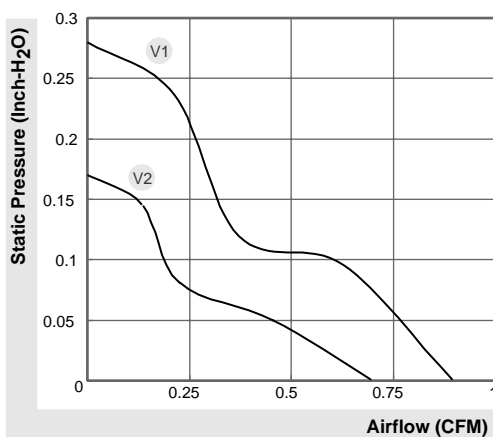

\*All model could be customized on voltage or any other requirements to fit your need.

\*Specifications subject to change without notice. Please Visit SUNON web site at <http://www.sunon.com> for update information.

# 20x20x8 mm

# SUNON

## MagLev Green Motor Fan

## 1.3~1.6 CFM



Model	P/N	Bearing ● VAPO ⊕ 2BALL	Rating Voltage (VDC)	Power Current (AMP)	Power Consumption (WATTS)	Speed (RPM)	Air Flow (CFM)	Static Pressure (Inch-H <sub>2</sub> O)	Noise (dBA)	Weight (g)
GM0501PDV1-8	GN	●	5	0.17	0.9	15000	1.6	0.22	23	4.64
GM0501PDV2-8	GN	⊕	5	0.11	0.6	12000	1.3	0.15	21	4.64

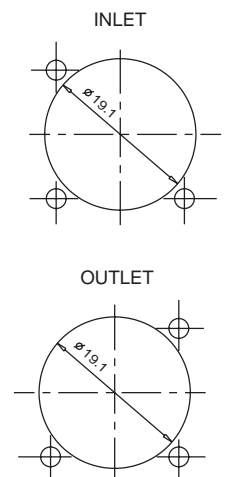
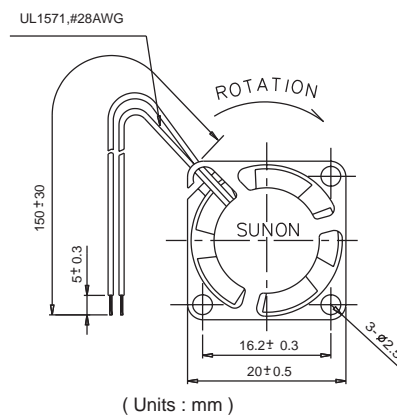
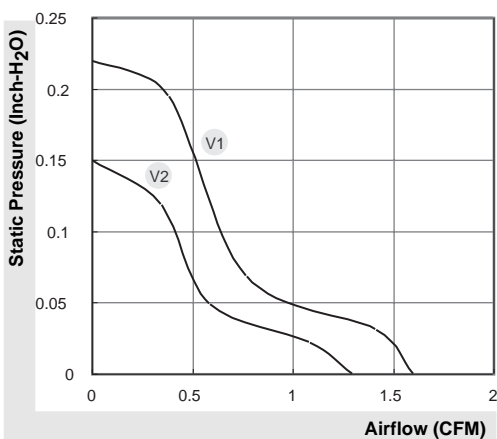

\*All model could be customized on voltage or any other requirements to fit your need.

\*Specifications subject to change without notice. Please Visit SUNON web site at <http://www.sunon.com> for update information.

# 20x20x10 mm

# SUNON

## MagLev Green Motor Fan

## 1.5~1.9 CFM



Model	P/N	Bearing ● VAPO ● 2BALL	Rating Voltage (VDC)	Power Current (AMP)	Power Consumption (WATTS)	Speed (RPM)	Air Flow (CFM)	Static Pressure (Inch-HzO)	Noise (dBA)	Weight (g)
GM0501PFV1-8	N.GN	●	5	0.21	1.1	17000	1.9	0.29	25	5.5
GM0501PFV2-8	N.GN	●	5	0.18	0.9	14000	1.5	0.20	20	5.5

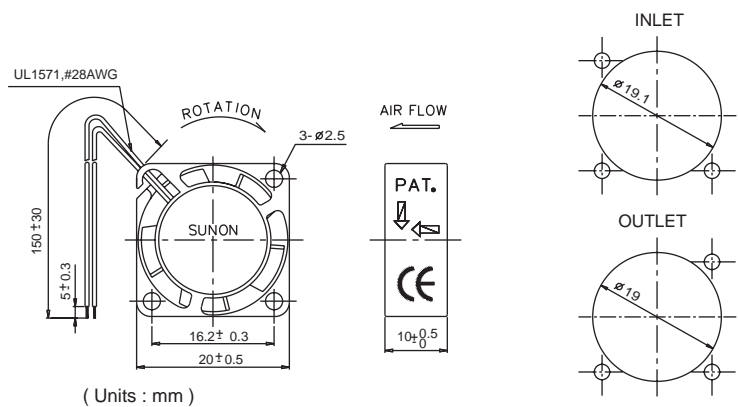
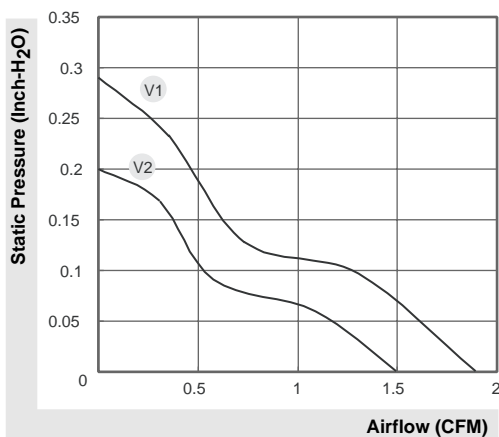

\*All model could be customized on voltage or any other requirements to fit your need.

\*Specifications subject to change without notice. Please Visit SUNON web site at <http://www.sunon.com> for update information.



# 25x25x6 mm

# SUNON

## MagLev Green Motor Fan

## 2.2~3.0 CFM



Model	P/N	Bearing ● VAPO ⊙ 2BALL	Rating Voltage (VDC)	Power Current (AMP)	Power Consumption (WATTS)	Speed (RPM)	Air Flow (CFM)	Static Pressure (Inch-H <sub>2</sub> O)	Noise (dBA)	Weight (g)
GM0502PEV1-8	N.GN	●	5	0.11	0.6	13000	3.0	0.22	31	5
GM0502PEV2-8	N.GN	●	5	0.08	0.4	10000	2.2	0.16	23	5

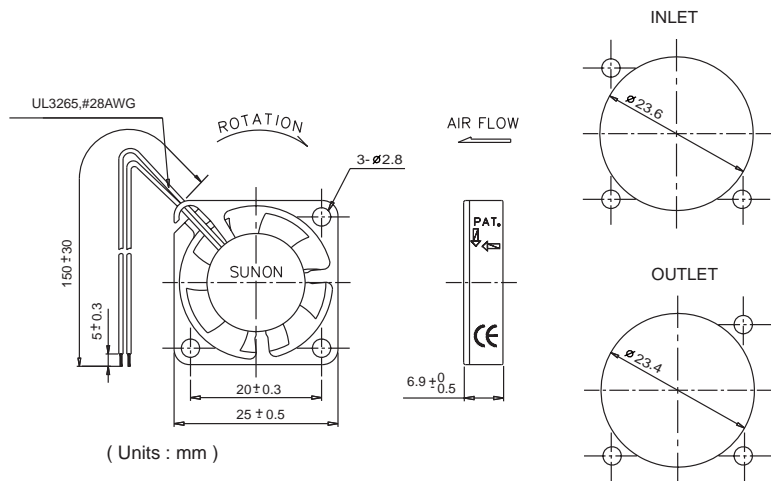
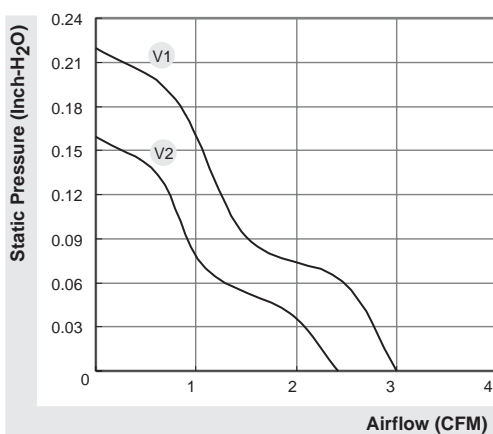

\*All model could be customized on voltage or any other requirements to fit your need.

\*Specifications subject to change without notice. Please Visit SUNON web site at <http://www.sunon.com> for update information.

# 25X25X10 mm

# SUNON

## MagLev Green Motor Fan

## 3.0~3.5 CFM



Model	P/N	Bearing ● VAPO ⊙ 2BALL	Rating Voltage (VDC)	Power Current (AMP)	Power Consumption (WATTS)	Speed (RPM)	Air Flow (CFM)	Static Pressure (Inch-H <sub>2</sub> O)	Noise (dBA)	Weight (g)
GM0502PFV1-8	GN	●	5	0.12	0.6	13000	3.5	0.25	23	7.5
GM0502PFV2-8	GN	●	5	0.08	0.4	10000	3.0	0.18	16	7.5
GM1202PFV1-8	GN	●	12	0.12	0.6	13000	3.5	0.25	23	7.5
GM1202PFV2-8	GN	●	12	0.08	0.4	10000	3.0	0.18	16	7.5

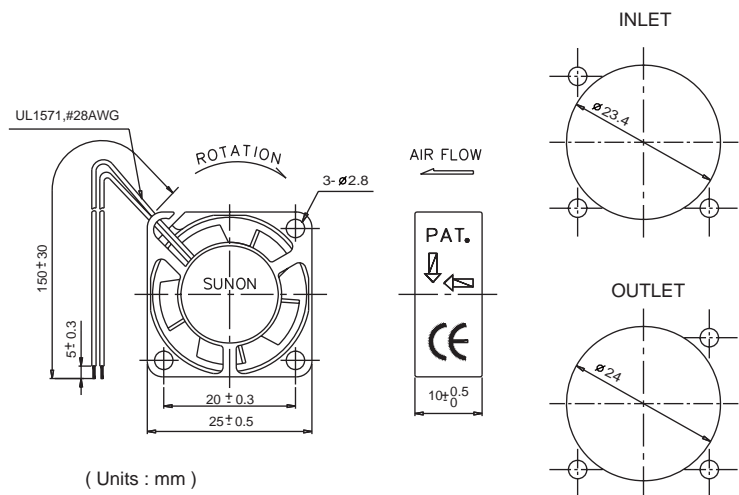
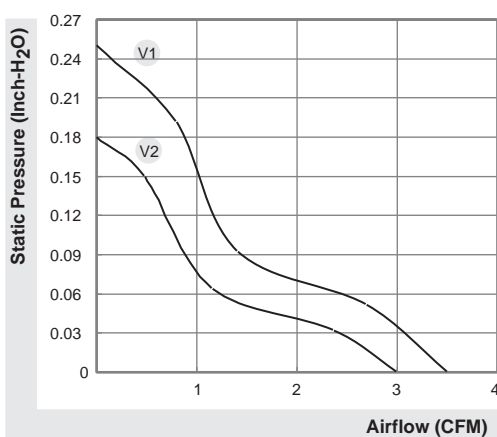

\*All model could be customized on voltage or any other requirements to fit your need.

\*Specifications subject to change without notice. Please Visit SUNON web site at <http://www.sunon.com> for update information.

# 25X25X15 mm

# SUNON

## MagLev Green Motor Fan

## 2.2~3.1 CFM

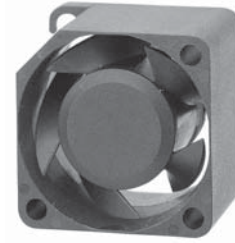

Model	P/N	Bearing ● VAPO ○ 2BALL	Rating Voltage (VDC)	Power Current (AMP)	Power Consumption (WATTS)	Speed (RPM)	Air Flow (CFM)	Static Pressure (Inch-H <sub>2</sub> O)	Noise (dBA)	Weight (g)
GM0502PHV1-8	GN	●	5	0.11	0.6	10000	3.1	0.16	20	11
GM0502PHV2-8	GN	●	5	0.08	0.4	7000	2.2	0.11	14	11
GM1202PHV1-8	GN	●	12	0.048	0.6	10000	3.1	0.16	20	11
GM1202PHV2-8	GN	●	12	0.029	0.4	7000	2.2	0.11	14	11

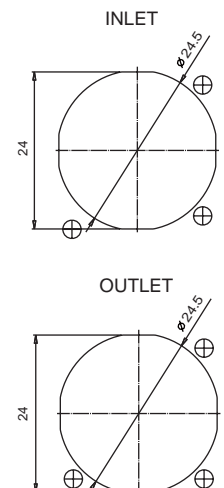
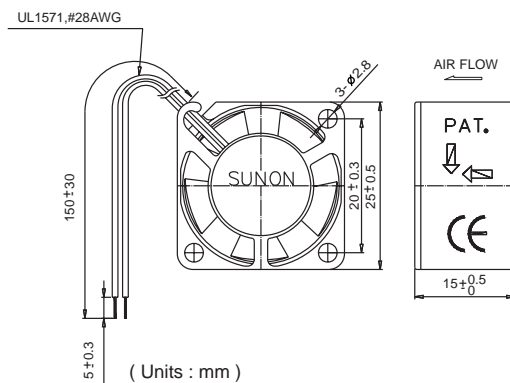
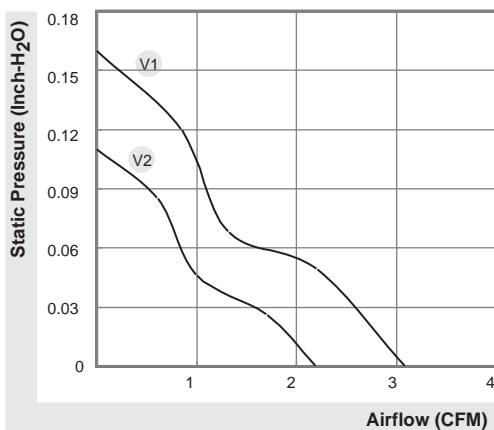

\*All model could be customized on voltage or any other requirements to fit your need.

\*Specifications subject to change without notice. Please Visit SUNON web site at <http://www.sunon.com> for update information.

# 30x30x6 mm

# SUNON

## MagLev Green Motor Fan

## 3.7~4.9 CFM



Model	P/N	Bearing	Rating Voltage (VDC)	Power Current (AMP)	Power Consumption (WATTS)	Speed (RPM)	Air Flow (CFM)	Static Pressure (Inch-H <sub>2</sub> O)	Noise (dBA)	Weight (g)
		● VAPO ⊙ 2BALL								
GM0503PEV1-8	N.GN	●	5	0.13	0.7	9500	4.9	0.14	28	6
GM0503PEV2-8	N.GN	●	5	0.08	0.4	7500	3.7	0.09	24	6

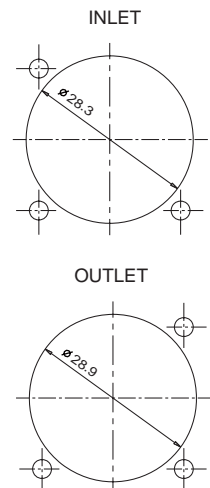
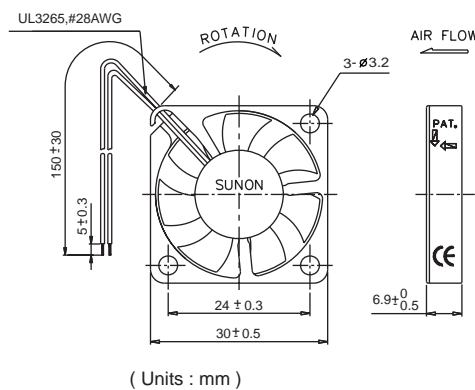
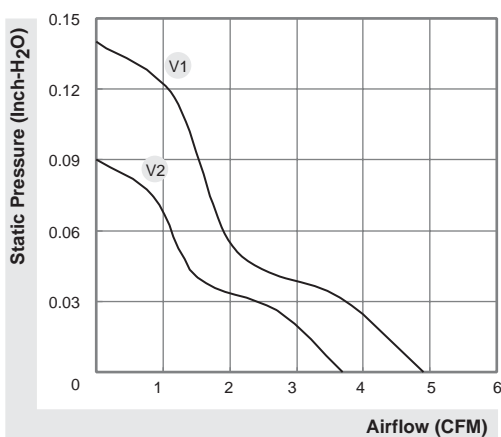

\*All model could be customized on voltage or any other requirements to fit your need.

\*Specifications subject to change without notice. Please Visit SUNON web site at <http://www.sunon.com> for update information.

# 30X30X10 mm

# SUNON

## MagLev Green Motor Fan

## 4.6~5.5 CFM



Model	P/N	Bearing ● VAPO ⊙ 2BALL	Rating Voltage (VDC)	Power Current (AMP)	Power Consumption (WATTS)	Speed (RPM)	Air Flow (CFM)	Static Pressure (Inch-H <sub>2</sub> O)	Noise (dBA)	Weight (g)
GM0503PFV1-8	GN	●	5	0.14	0.7	9500	5.5	0.15	23	8.6
GM0503PFV2-8	GN	●	5	0.10	0.5	8000	4.6	0.12	20	8.6
GM1203PFV1-8	GN	●	12	0.078	1.0	9500	5.5	0.15	23	8.5
GM1203PFV2-8	GN	●	12	0.042	0.5	8000	4.6	0.12	20	8.5

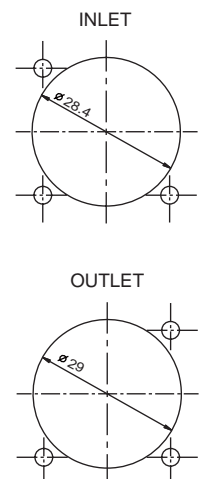
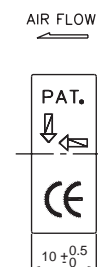
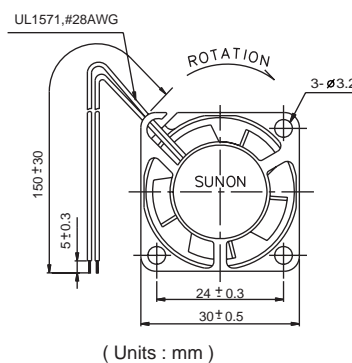
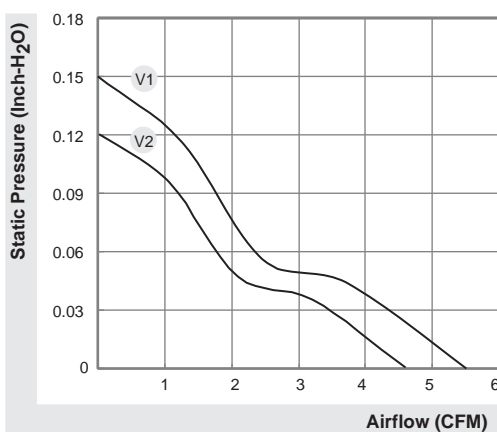

\*All model could be customized on voltage or any other requirements to fit your need.

\*Specifications subject to change without notice. Please Visit SUNON web site at <http://www.sunon.com> for update information.

# 30X30X15 mm

# SUNON

## MagLev Green Motor Fan

## 4.8~6.0 CFM



Model	P/N	Bearing ● VAPO ⊙ 2BALL	Rating Voltage (VDC)	Power Current (AMP)	Power Consumption (WATTS)	Speed (RPM)	Air Flow (CFM)	Static Pressure (Inch-H <sub>2</sub> O)	Noise (dBA)	Weight (g)
GM0503PHV1-8	GN	●	5	0.11	0.6	8500	6.0	0.17	27	13.5
GM0503PHV2-8	GN	●	5	0.07	0.4	7000	4.8	0.12	20	13.5
GM1203PHV1-8	GN	●	12	0.054	0.6	8500	6.0	0.17	27	13.2
GM1203PHV2-8	GN	●	12	0.029	0.4	7000	4.8	0.12	20	13.2

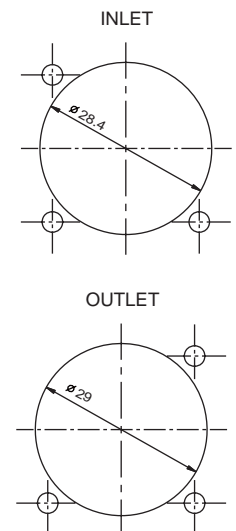
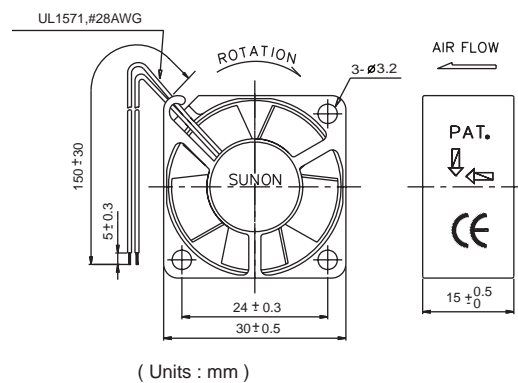
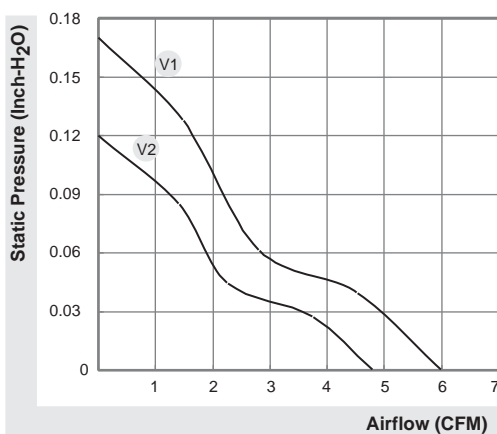

\*All model could be customized on voltage or any other requirements to fit your need.

\*Specifications subject to change without notice. Please Visit SUNON web site at <http://www.sunon.com> for update information.

# 35x35x6 mm

# SUNON

## MagLev Green Motor Fan

## 4.3~5.5 CFM



Model	P/N	Bearing ● VAPO ⊙ 2BALL	Rating Voltage (VDC)	Power Current (AMP)	Power Consumption (WATTS)	Speed (RPM)	Air Flow (CFM)	Static Pressure (Inch-H <sub>2</sub> O)	Noise (dBA)	Weight (g)
GM0535PEV1-8	N.GN	●	5	0.14	0.7	7600	5.5	0.08	26	7
GM0535PEV2-8	N.GN	●	5	0.09	0.5	5800	4.3	0.06	19	7

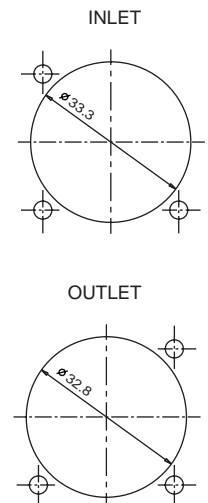
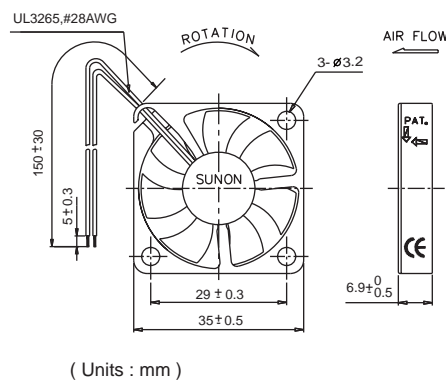
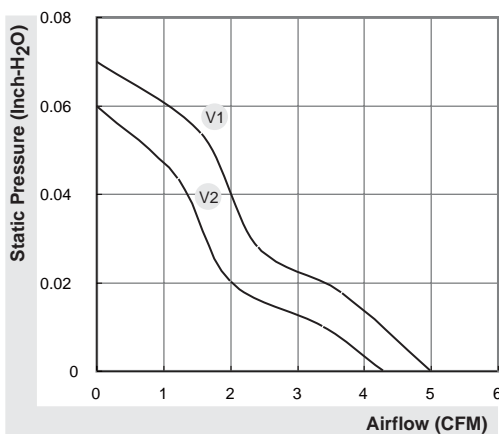

\*All model could be customized on voltage or any other requirements to fit your need.

\*Specifications subject to change without notice. Please Visit SUNON web site at <http://www.sunon.com> for update information.

# 35X35X10 mm

# SUNON

## MagLev Green Motor Fan

### 6.5~7.0 CFM



Model	P/N	Bearing ● VAPO ⊙ 2BALL	Rating Voltage (VDC)	Power Current (AMP)	Power Consumption (WATTS)	Speed (RPM)	Air Flow (CFM)	Static Pressure (Inch-H <sub>2</sub> O)	Noise (dBA)	Weight (g)
GM0535PFV1-8	GN	●	5	0.15	0.8	9500	7.0	0.18	28	10.5
GM0535PFV2-8	GN	●	5	0.10	0.5	7500	6.5	0.12	22	10.5
GM1235PFV1-8	GN	●	12	0.08	1.0	9500	7.0	0.18	28	10.5
GM1235PFV2-8	GN	●	12	0.043	0.5	7500	6.5	0.12	22	10.5

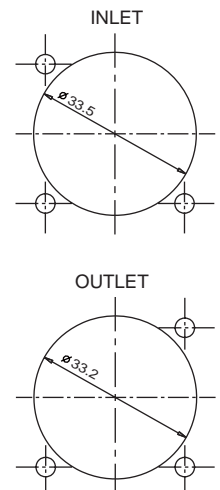
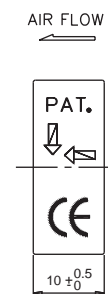
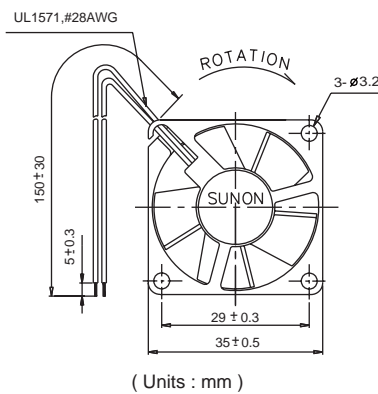
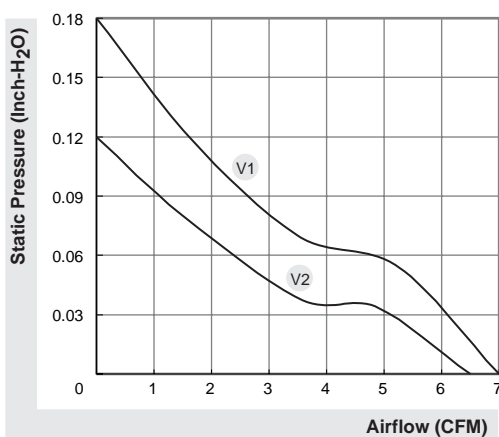

\*All model could be customized on voltage or any other requirements to fit your need.

\*Specifications subject to change without notice. Please Visit SUNON web site at <http://www.sunon.com> for update information.



# 40x40x6 mm

# SUNON

## MagLev Green Motor Fan

### 5.5~5.9 CFM



Model	P/N	Bearing ● VAPO ⊙ 2BALL	Rating Voltage (VDC)	Power Current (AMP)	Power Consumption (WATTS)	Speed (RPM)	Air Flow (CFM)	Static Pressure (Inch-H <sub>2</sub> O)	Noise (dBA)	Weight (g)
GM0504PEV1-8	GN	●	5	0.09	0.5	7000	5.9	0.10	32	7.5
GM0504PEV2-8	GN	●	5	0.07	0.4	6000	5.5	0.08	26	7.5

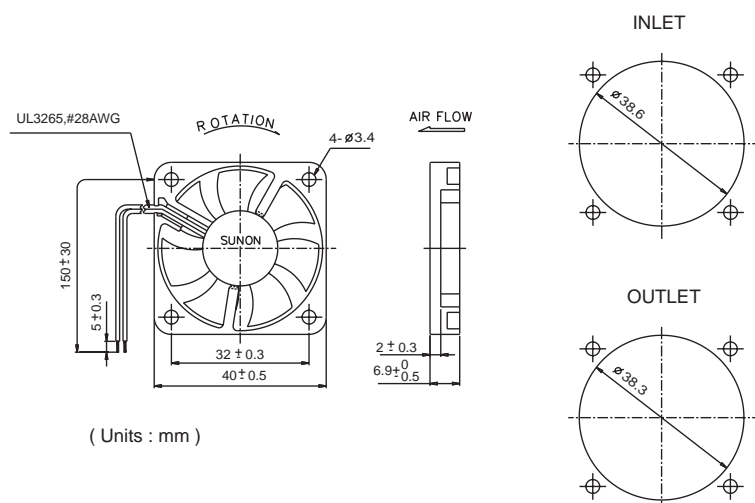
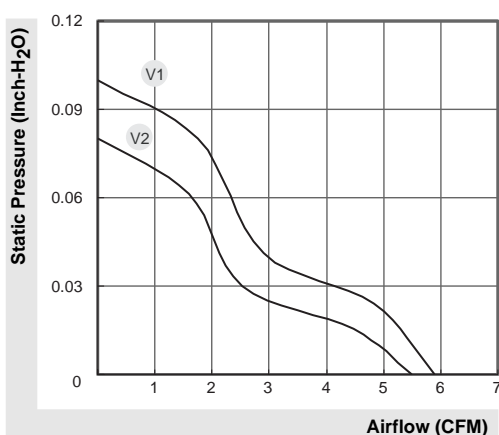

\*All model could be customized on voltage or any other requirements to fit your need.

\*Specifications subject to change without notice. Please Visit SUNON web site at <http://www.sunon.com> for update information.

# 40X40X10 mm

# SUNON

## MagLev Motor Fan

## 7.0~9.5 CFM



Model	P/N	Bearing ● VAPO ⊙ 2BALL	Rating Voltage (VDC)	Power Current (AMP)	Power Consumption (WATTS)	Speed (RPM)	Air Flow (CFM)	Static Pressure (Inch-H <sub>2</sub> O)	Noise (dBA)	Weight (g)
KDE0504PFV1	11.MS.A.GN	●	5	0.24	1.2	7000	8.0	0.19	32	17
KDE0504PFV2	11.MS.A.GN	●	5	0.14	0.7	5800	7.0	0.13	27	17
KDE1204PFVX	11.MS.A.GN	●	12	0.15	1.8	8500	9.5	0.25	39	17
KDE1204PFV1	11.MS.A.GN	●	12	0.09	1.1	7000	8.0	0.19	32	17
KDE1204PFV2	11.MS.A.GN	●	12	0.08	1.0	5800	7.0	0.13	27	17
KDE2404PFVX	11.MS.A.GN	●	24	0.077	1.9	8500	9.5	0.25	39	17

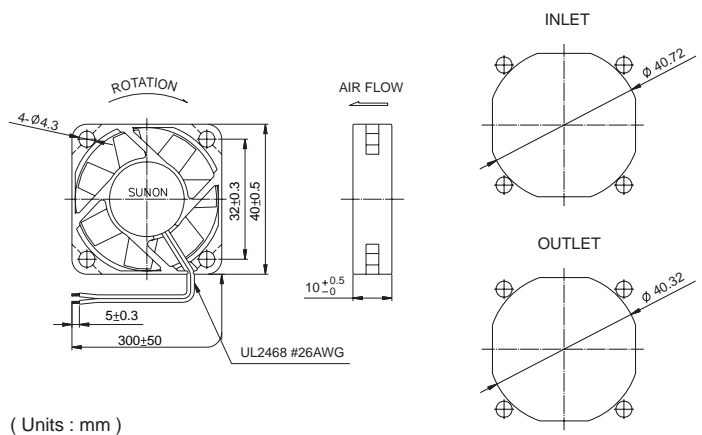
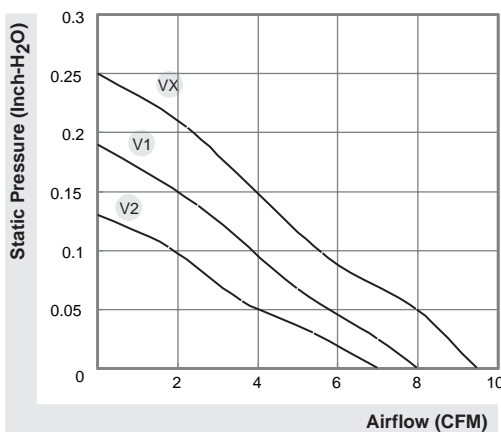

\*All model could be customized on voltage or any other requirements to fit your need.

\*Specifications subject to change without notice. Please Visit SUNON web site at <http://www.sunon.com> for update information.

# 40X40X20 mm

# SUNON

## MagLev Motor Fan

## 6.3~10.8 CFM



Model	P/N	Bearing ● VAPO ⊙ 2BALL	Rating Voltage (VDC)	Power Current (AMP)	Power Consumption (WATTS)	Speed (RPM)	Air Flow (CFM)	Static Pressure (Inch-H <sub>2</sub> O)	Noise (dBA)	Weight (g)
KDE0504PKV1	MS.A.GN	●	5	0.19	1.0	7200	8.9	0.21	25.5	30
KDE0504PKV2	MS.A.GN	●	5	0.12	0.6	6200	7.7	0.16	21.0	30
KDE0504PKV3	MS.A.GN	●	5	0.08	0.4	5200	6.3	0.11	18.0	30
KDE1204PKVX	MS.A.GN	●	12	0.12	1.4	8200	10.8	0.27	27.5	31
KDE1204PKV1	MS.A.GN	●	12	0.07	0.8	7200	8.9	0.21	25.5	31
KDE1204PKV2	MS.A.GN	●	12	0.05	0.6	6200	7.7	0.16	21.0	31
KDE1204PKV3	MS.A.GN	●	12	0.03	0.4	5200	6.3	0.11	18.0	31
KDE2404PKVX	MS.A.GN	●	24	0.064	1.5	8200	10.8	0.27	27.5	31
KDE2404PKV1	MS.A.GN	●	24	0.05	1.2	7200	8.9	0.21	25.5	31
KDE2404PKV2	MS.A.GN	●	24	0.033	0.8	6200	7.7	0.16	21.0	31

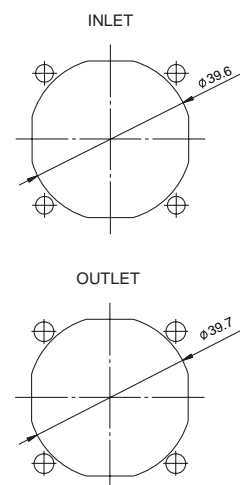
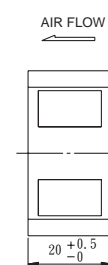
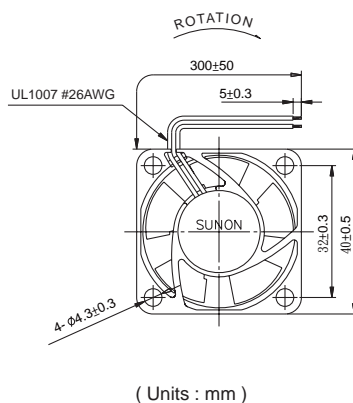
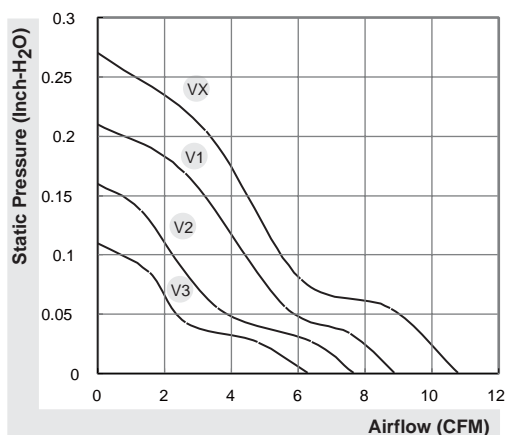

\*All model could be customized on voltage or any other requirements to fit your need.

\*Specifications subject to change without notice. Please Visit SUNON web site at <http://www.sunon.com> for update information.

# 45X45X10 mm

# SUNON

## MagLev Motor Fan

## 9.2~12.5 CFM



Model	P/N	Bearing ● VAPO ○ 2BALL	Rating Voltage (VDC)	Power Current (AMP)	Power Consumption (WATTS)	Speed (RPM)	Air Flow (CFM)	Static Pressure (Inch-H <sub>2</sub> O)	Noise (dBA)	Weight (g)
KDE0545PFV1	11.MS.A.GN	●	5	0.25	1.3	6000	11.0	0.17	32	19.0
KDE0545PFV2	11.MS.A.GN	●	5	0.15	0.8	5000	9.2	0.12	27	19.0
KDE1245PFVX	11.MS.A.GN	●	12	0.16	1.9	7100	12.5	0.22	35	18.5
KDE1245PFV1	11.MS.A.GN	●	12	0.10	1.2	6000	11.0	0.17	32	18.5
KDE1245PFV2	11.MS.A.GN	●	12	0.08	1.0	5000	9.2	0.12	27	18.5
KDE2445PFVX	11.MS.A.GN	●	24	0.084	2.0	7100	12.5	0.22	35	19.0

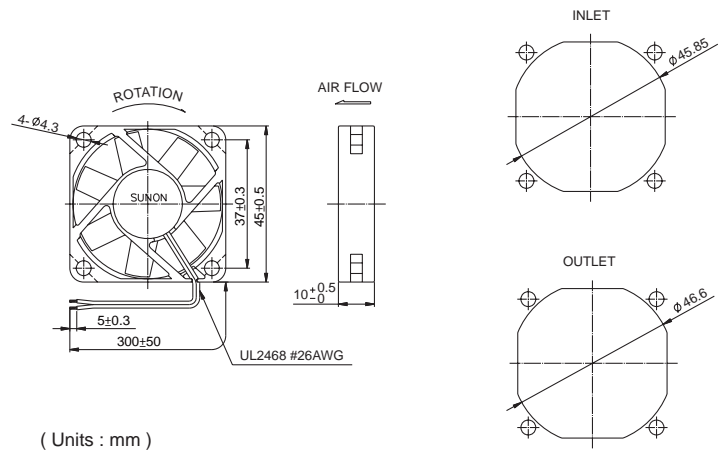
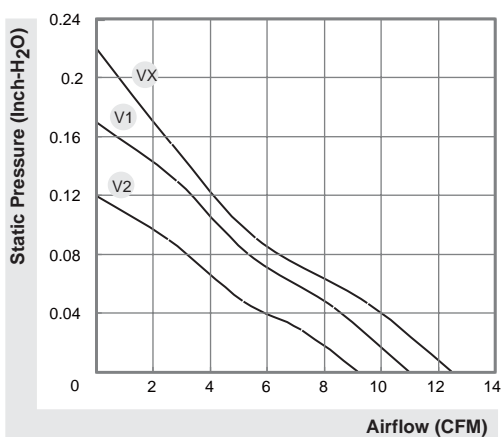

\*All model could be customized on voltage or any other requirements to fit your need.

\*Specifications subject to change without notice. Please Visit SUNON web site at <http://www.sunon.com> for update information.

# 50X50X10 mm

# SUNON

## MagLev Motor Fan

## 11~15.2 CFM



Model	P/N	Bearing ● VAPO ⊙ 2BALL	Rating Voltage (VDC)	Power Current (AMP)	Power Consumption (WATTS)	Speed (RPM)	Air Flow (CFM)	Static Pressure (Inch-H <sub>2</sub> O)	Noise (dBA)	Weight (g)
KDE0505PFV1	11.MS.A.GN	●	5	0.27	1.4	5200	13.0	0.14	30	21
KDE0505PFV2	11.MS.A.GN	●	5	0.16	0.8	4300	11.0	0.11	26	21
KDE1205PFVX	11.MS.A.GN	●	12	0.17	2.0	6100	15.2	0.18	35	20
KDE1205PFV1	11.MS.A.GN	●	12	0.11	1.3	5200	13.0	0.14	30	20
KDE1205PFV2	11.MS.A.GN	●	12	0.09	1.1	4300	11.0	0.11	26	20
KDE2405PFVX	11.MS.A.GN	●	24	0.091	2.2	6100	15.2	0.18	35	21

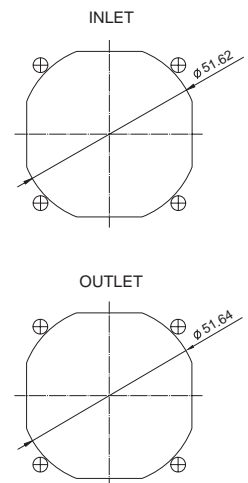
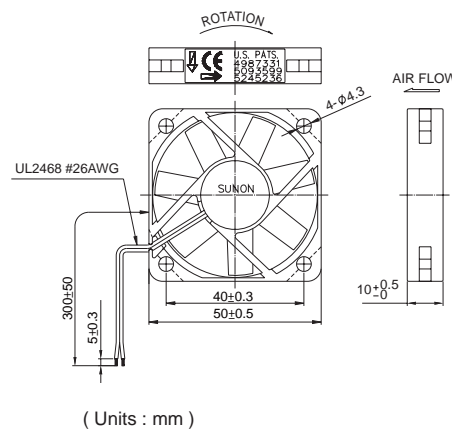
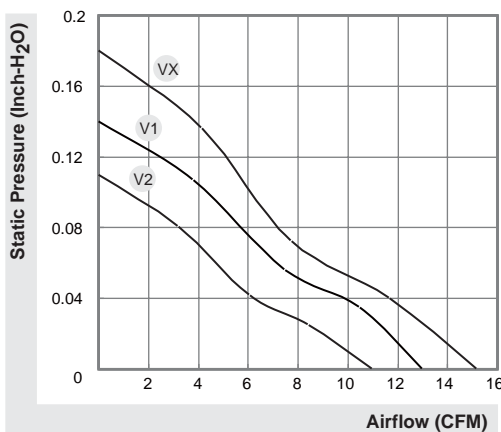

\*All model could be customized on voltage or any other requirements to fit your need.

\*Specifications subject to change without notice. Please Visit SUNON web site at <http://www.sunon.com> for update information.

# 50X50X15 mm

# SUNON

## MagLev Motor Fan

## 10.2~17 CFM



Model	P/N	Bearing ● VAPO ⊙ 2BALL	Rating Voltage (VDC)	Power Current (AMP)	Power Consumption (WATTS)	Speed (RPM)	Air Flow (CFM)	Static Pressure (Inch-H <sub>2</sub> O)	Noise (dBA)	Weight (g)
KDE0505PHV2	MS.A.GN	●	5	0.15	0.8	4700	13.0	0.17	29	39
KDE0505PHV3	MS.A.GN	●	5	0.09	0.5	3700	10.2	0.12	22	39
KDE1205PHV1	MS.A.GN	●	12	0.11	1.3	5800	17.0	0.23	33	38
KDE1205PHV2	MS.A.GN	●	12	0.07	0.8	4700	13.0	0.17	29	38
KDE1205PHV3	MS.A.GN	●	12	0.04	0.5	3700	10.2	0.12	22	38
KDE2405PHV1	MS.A.GN	●	24	0.063	1.5	5800	17.0	0.23	33	39
KDE2405PHV2	MS.A.GN	●	24	0.042	1.0	4700	13.0	0.17	29	39

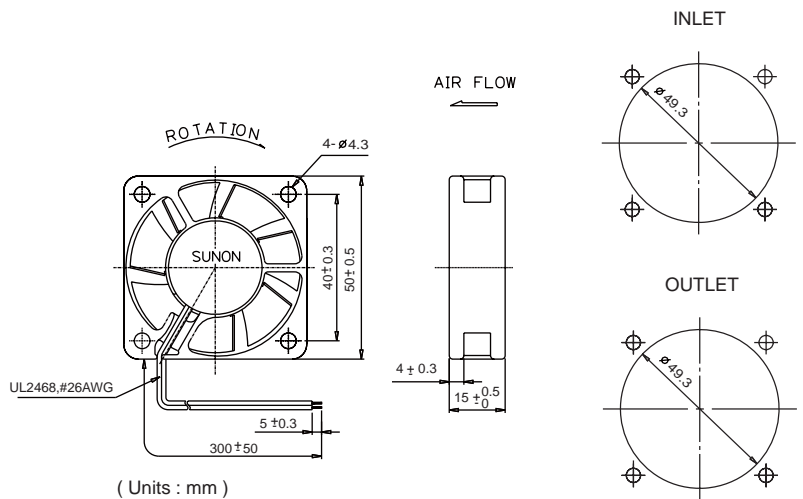
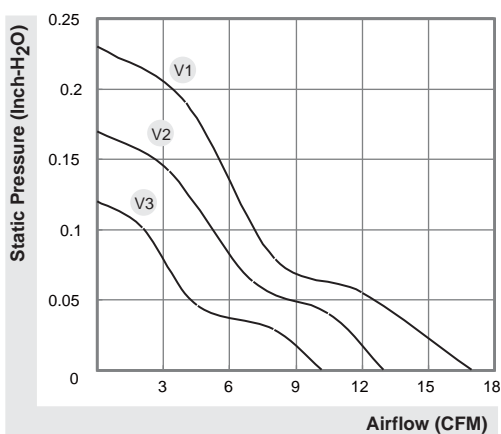

\*All model could be customized on voltage or any other requirements to fit your need.

\*Specifications subject to change without notice. Please Visit SUNON web site at <http://www.sunon.com> for update information.

## MagLev Motor Fan

### 11.7~16 CFM



Model	P/N	Bearing ● VAPO ⊙ 2BALL	Rating Voltage (VDC)	Power Current (AMP)	Power Consumption (WATTS)	Speed (RPM)	Air Flow (CFM)	Static Pressure (Inch-HzO)	Noise (dBA)	Weight (g)
KDE0506PFV2	MS.G.(9).A.GN	●	5	0.20	1.0	3500	13.6	0.10	25.0	29
KDE0506PFV3	MS.G.(9).A.GN	●	5	0.13	0.7	3000	11.7	0.08	21.5	29
KDE1206PFV1	MS.G.(9).A.GN	●	12	0.12	1.4	4000	16.0	0.12	28.5	29
KDE1206PFV2	MS.G.(9).A.GN	●	12	0.08	1.0	3500	13.6	0.10	25.0	29
KDE1206PFV3	MS.G.(9).A.GN	●	12	0.05	0.6	3000	11.7	0.08	21.5	29

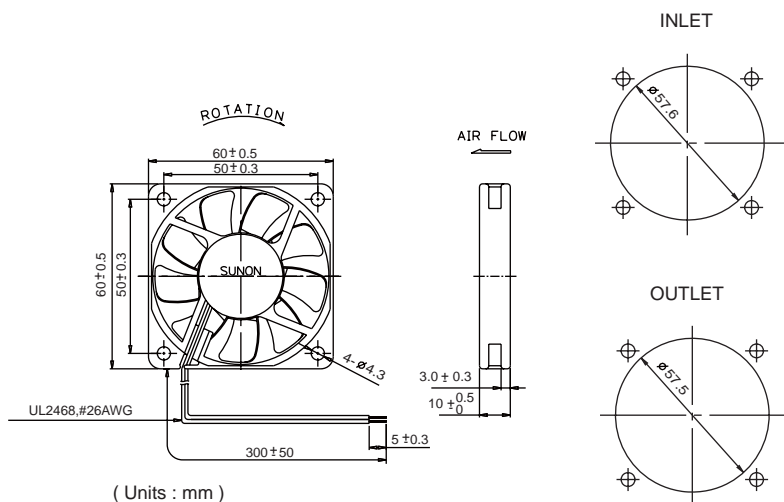
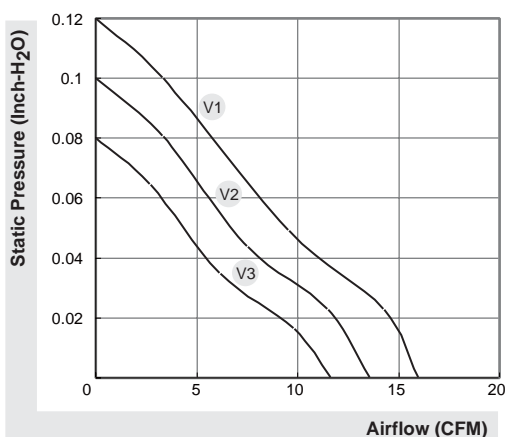

\*All model could be customized on voltage or any other requirements to fit your need.

\*Specifications subject to change without notice. Please Visit SUNON web site at <http://www.sunon.com> for update information.

# 60x60x15 mm

# SUNON

## MagLev Motor Fan

## 15~21 CFM



Model	P/N	Bearing ● VAPO ⊙ 2BALL	Rating Voltage (VDC)	Power Current (AMP)	Power Consumption (WATTS)	Speed (RPM)	Air Flow (CFM)	Static Pressure (Inch-H <sub>2</sub> O)	Noise (dBA)	Weight (g)
KDE0506PHV2	MS.A.GN	●	5	0.18	0.9	3800	18	0.14	31	44
KDE0506PHV3	MS.A.GN	●	5	0.10	0.5	3000	15	0.12	25	44
KDE1206PHV1	MS.A.GN	●	12	0.13	1.6	4300	21	0.18	36	42
KDE1206PHV2	MS.A.GN	●	12	0.08	1.0	3800	18	0.14	31	42
KDE1206PHV3	MS.A.GN	●	12	0.05	0.6	3000	15	0.12	25	42
KDE2406PHV1	MS.A.GN	●	24	0.077	1.9	4300	21	0.18	36	44
KDE2406PHV2	MS.A.GN	●	24	0.054	1.3	3800	18	0.14	31	44

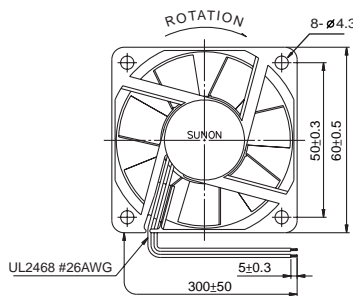
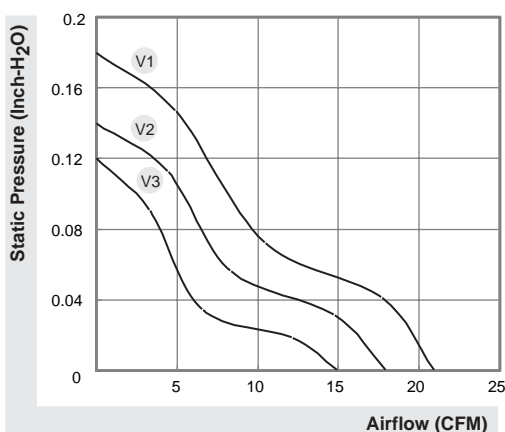

( Units : mm )

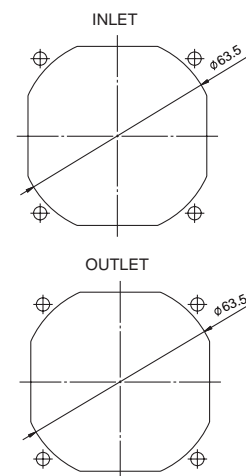

\*All model could be customized on voltage or any other requirements to fit your need.

\*Specifications subject to change without notice. Please Visit SUNON web site at <http://www.sunon.com> for update information.



## MagLev Motor Fan

### 19~25.5 CFM



Model	P/N	Bearing ● VAPO ⊙ 2BALL	Rating Voltage (VDC)	Power Current (AMP)	Power Consumption (WATTS)	Speed (RPM)	Air Flow (CFM)	Static Pressure (Inch-H <sub>2</sub> O)	Noise (dBA)	Weight (g)
KDE1206PKVX	MS.A.GN	●	12	0.24	2.9	5100	25.5	0.24	39.0	52
KDE1206PKV1	MS.A.GN	●	12	0.15	1.8	4500	23.0	0.18	33.5	52
KDE1206PKV2	MS.A.GN	●	12	0.07	0.8	3700	19.0	0.14	28.0	52
KDE2406PKVX	MS.A.GN	●	24	0.125	3.0	5100	25.5	0.24	39.0	52
KDE2406PKV1	MS.A.GN	●	24	0.078	1.9	4500	23.0	0.18	33.5	52
KDE2406PKV2	MS.A.GN	●	24	0.047	1.1	3700	19.0	0.14	28.0	52

\*High air flow products please see page 40.

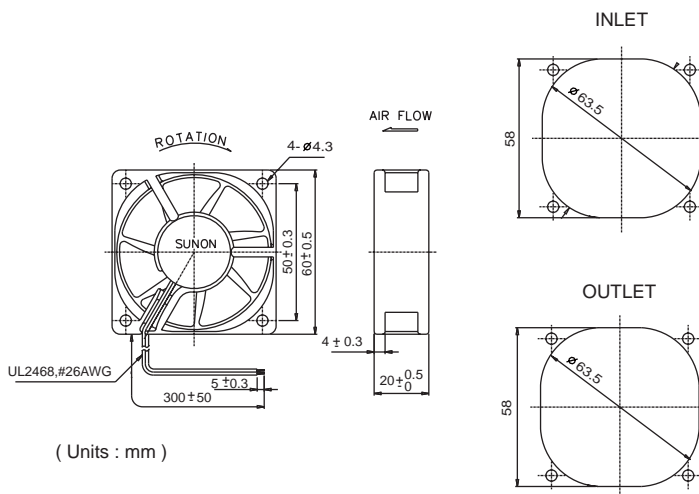
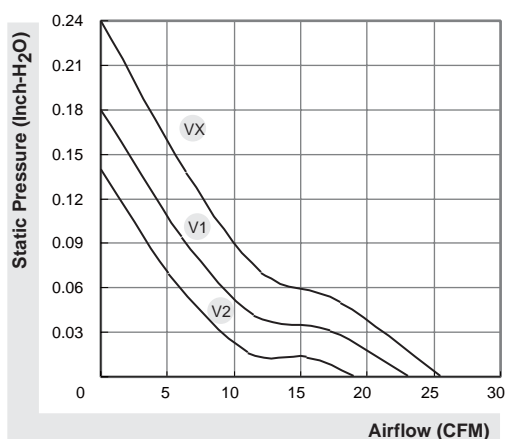

\*All model could be customized on voltage or any other requirements to fit your need.

\*Specifications subject to change without notice. Please Visit SUNON web site at <http://www.sunon.com> for update information.

## MagLev Motor Fan

### 19.3~27 CFM



Model	P/N	Bearing	Rating Voltage (VDC)	Power Current (AMP)	Power Consumption (WATTS)	Speed (RPM)	Air Flow (CFM)	Static Pressure (Inch-H <sub>2</sub> O)	Noise (dBA)	Weight (g)
KDE1206PTVX	MS.A.GN	● VAP0	12	0.23	2.8	5200	27.0	0.31	36.5	55
KDE1206PTV1	MS.A.GN	● 2BALL	12	0.14	1.7	4500	23.5	0.21	33.5	55
KDE1206PTV2	MS.A.GN	● 2BALL	12	0.07	0.8	3800	19.3	0.15	29.0	55
KDE2406PTVX	MS.A.GN	● VAP0	24	0.114	2.7	5200	27.0	0.31	36.5	56
KDE2406PTV1	MS.A.GN	● 2BALL	24	0.079	1.9	4500	23.5	0.21	33.5	56
KDE2406PTV2	MS.A.GN	● 2BALL	24	0.048	1.2	3800	19.3	0.15	29.0	56

\*High air flow products please see page 41.

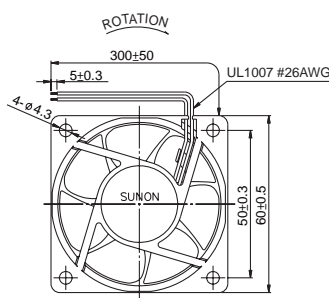
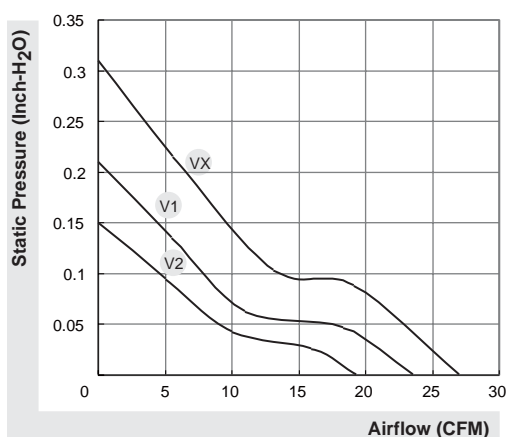

(Units : mm)

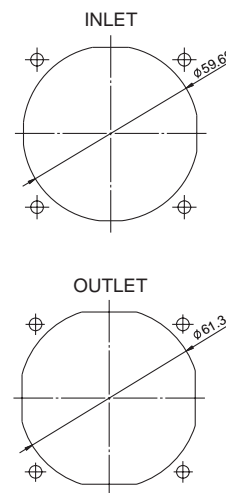
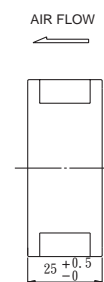

\*All model could be customized on voltage or any other requirements to fit your need.

\*Specifications subject to change without notice. Please Visit SUNON web site at <http://www.sunon.com> for update information.

# 70X70X10 mm

# SUNON

## MagLev Motor Fan

## 14.5~20.5 CFM



Model	P/N	Bearing ● VAPO ○ 2BALL	Rating Voltage (VDC)	Power Current (AMP)	Power Consumption (WATTS)	Speed (RPM)	Air Flow (CFM)	Static Pressure (Inch-H <sub>2</sub> O)	Noise (dBA)	Weight (g)
KDE0507PFV2	MS.G.A.GN	●	5	0.22	1.1	2500	17.0	0.06	24.5	29
KDE0507PFV3	MS.G.A.GN	●	5	0.13	0.7	2100	14.5	0.05	20.5	29
KDE1207PFV1	MS.G.A.GN	●	12	0.14	1.7	3000	20.5	0.08	28.0	29
KDE1207PFV2	MS.G.A.GN	●	12	0.09	1.1	2500	17.0	0.06	24.5	29
KDE1207PFV3	MS.G.A.GN	●	12	0.06	0.7	2100	14.5	0.05	20.5	29

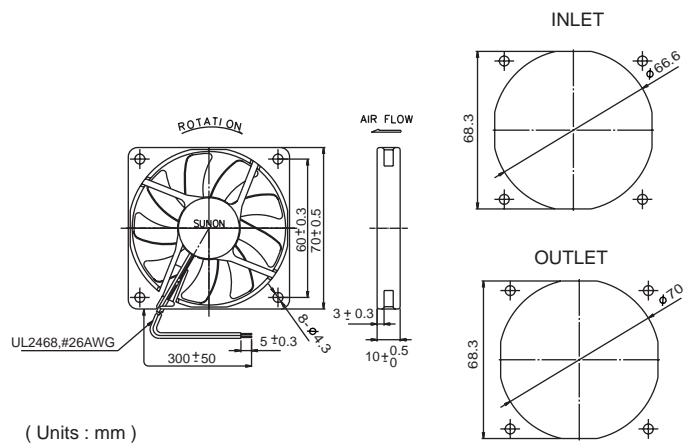
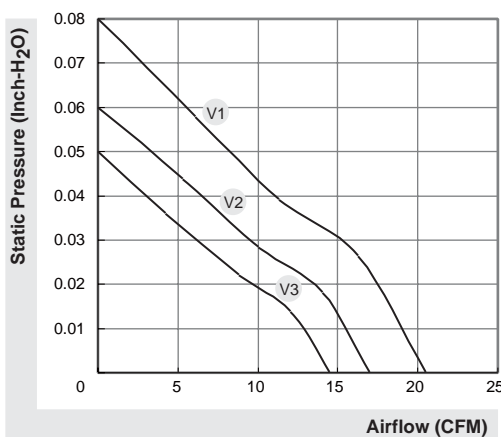

\*All model could be customized on voltage or any other requirements to fit your need.

\*Specifications subject to change without notice. Please Visit SUNON web site at <http://www.sunon.com> for update information

# 70X70X15 mm

# SUNON

## MagLev Motor Fan

## 19~27 CFM



Model	P/N	Bearing ● VAPO ⊙ 2BALL	Rating Voltage (VDC)	Power Current (AMP)	Power Consumption (WATTS)	Speed (RPM)	Air Flow (CFM)	Static Pressure (Inch-H <sub>2</sub> O)	Noise (dBA)	Weight (g)
KDE0507PHV2	MS.A.GN	●	5	0.2	1.0	2800	23	0.09	26.5	52
KDE0507PHV3	MS.A.GN	●	5	0.11	0.6	2300	19	0.07	21.5	52
KDE1207PHV1	MS.A.GN	●	12	0.16	1.9	3300	27	0.11	31.5	50
KDE1207PHV2	MS.A.GN	●	12	0.09	1.1	2800	23	0.09	26.5	50
KDE1207PHV3	MS.A.GN	●	12	0.05	0.6	2300	19	0.07	21.5	50
KDE2407PHV1	MS.A.GN	●	24	0.086	2.1	3300	27	0.11	31.5	52
KDE2407PHV2	MS.A.GN	●	24	0.054	1.3	2800	23	0.09	26.5	52

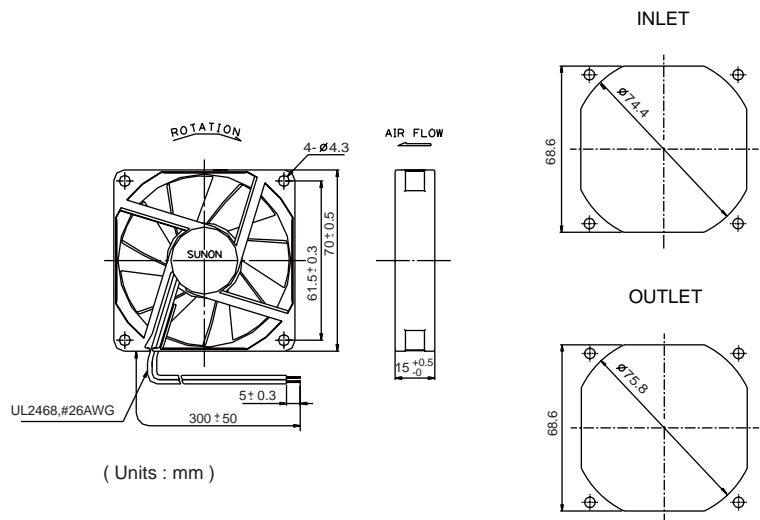
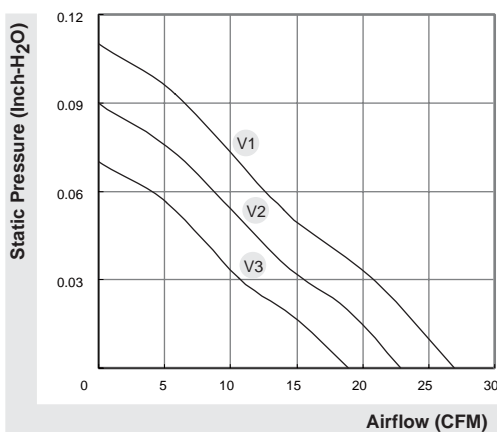

\*All model could be customized on voltage or any other requirements to fit your need.

\*Specifications subject to change without notice. Please Visit SUNON web site at <http://www.sunon.com> for update information.

# 70x70x20 mm

# SUNON

## MagLev Motor Fan

## 23.5~29 CFM



Model	P/N	Bearing ● VAPO ⊙ 2BALL	Rating Voltage (VDC)	Power Current (AMP)	Power Consumption (WATTS)	Speed (RPM)	Air Flow (CFM)	Static Pressure (Inch-H <sub>2</sub> O)	Noise (dBA)	Weight (g)
KDE1207PKV1	13.MS.A.GN	●	12	0.12	1.4	3200	29.0	0.14	33	66
KDE1207PKV2	13.MS.A.GN	●	12	0.10	1.2	2900	27.0	0.12	30	66
KDE1207PKV3	13.MS.A.GN	●	12	0.07	0.8	2600	23.5	0.09	26	66
KDE2407PKV1	13.MS.A.GN	●	24	0.07	1.7	3200	29.0	0.14	33	68
KDE2407PKV2	13.MS.A.GN	●	24	0.05	1.2	2900	27.0	0.12	30	68
KDE2407PKV3	13.MS.A.GN	●	24	0.04	1.0	2600	23.5	0.09	26	68

\*High air flow products please see page 43.

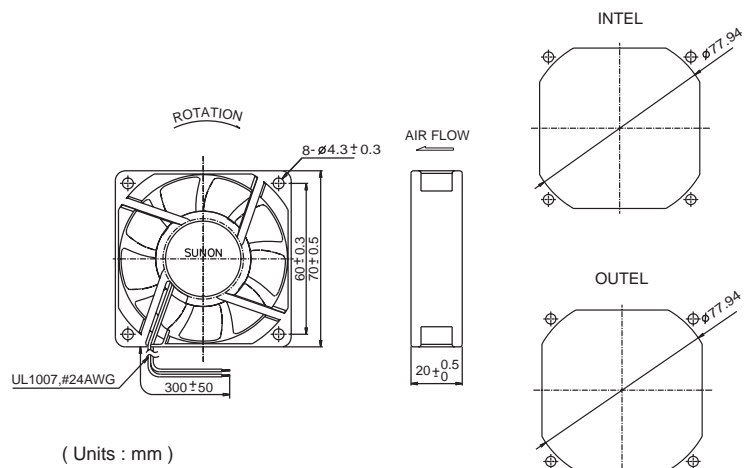
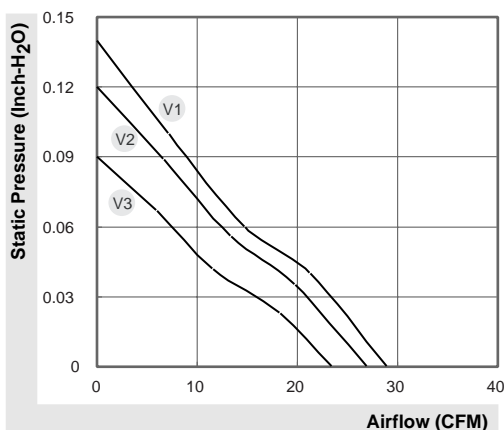

\*All model could be customized on voltage or any other requirements to fit your need.

\*Specifications subject to change without notice. Please Visit SUNON web site at <http://www.sunon.com> for update information.

## MagLev Motor Fan 24~31 CFM



Model	P/N	Bearing ● VAPO ⊙ 2BALL	Rating Voltage (VDC)	Power Current (AMP)	Power Consumption (WATTS)	Speed (RPM)	Air Flow (CFM)	Static Pressure (Inch-HzO)	Noise (dBA)	Weight (g)
KDE1207PTV1	13.MS.A.GN	●	12	0.12	1.4	3200	31	0.15	32	70
KDE1207PTV2	13.MS.A.GN	●	12	0.09	1.1	2900	28	0.13	29	70
KDE1207PTV3	13.MS.A.GN	●	12	0.06	0.7	2500	24	0.10	25	70
KDE2407PTV1	13.MS.A.GN	●	24	0.06	1.4	3200	31	0.15	32	72
KDE2407PTV2	13.MS.A.GN	●	24	0.05	1.2	2900	28	0.13	29	72
KDE2407PTV3	13.MS.A.GN	●	24	0.04	1.0	2500	24	0.10	25	72

\*High air flow products please see page 44.

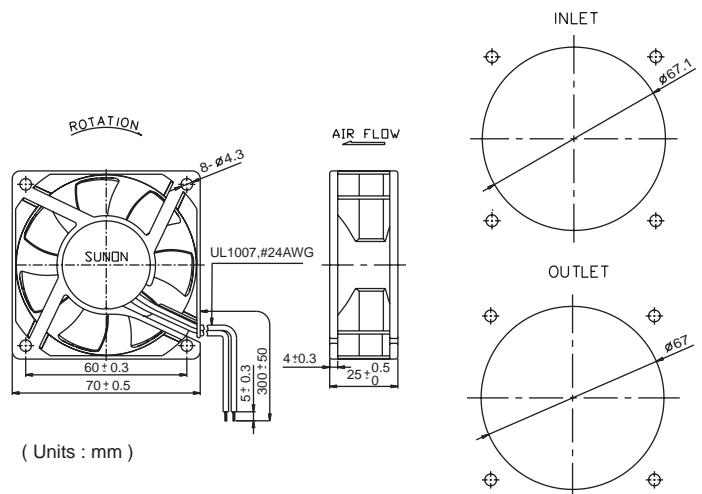
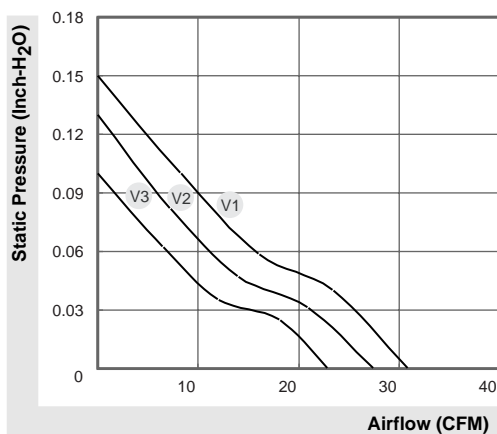

\*All model could be customized on voltage or any other requirements to fit your need.

\*Specifications subject to change without notice. Please Visit SUNON web site at <http://www.sunon.com> for update information.

# 80x80x20 mm

# SUNON

## MagLev Motor Fan

## 29~36 CFM



Model	P/N	Bearing ● VAPO ⊙ 2BALL	Rating Voltage (VDC)	Power Current (AMP)	Power Consumption (WATTS)	Speed (RPM)	Air Flow (CFM)	Static Pressure (Inch-H <sub>2</sub> O)	Noise (dBA)	Weight (g)
KDE1208PKV1	13.MS.A.GN	●	12	0.13	1.6	3200	36	0.18	38	72
KDE1208PKV2	13.MS.A.GN	●	12	0.10	1.2	2900	33	0.16	35	72
KDE1208PKV3	13.MS.A.GN	●	12	0.07	0.8	2500	29	0.12	30	72
KDE2408PKV1	13.MS.A.GN	●	24	0.07	1.7	3200	36	0.18	38	72
KDE2408PKV2	13.MS.A.GN	●	24	0.05	1.2	2900	33	0.16	35	72
KDE2408PKV3	13.MS.A.GN	●	24	0.04	1.0	2500	29	0.12	30	72

\*High air flow products please see page 46.

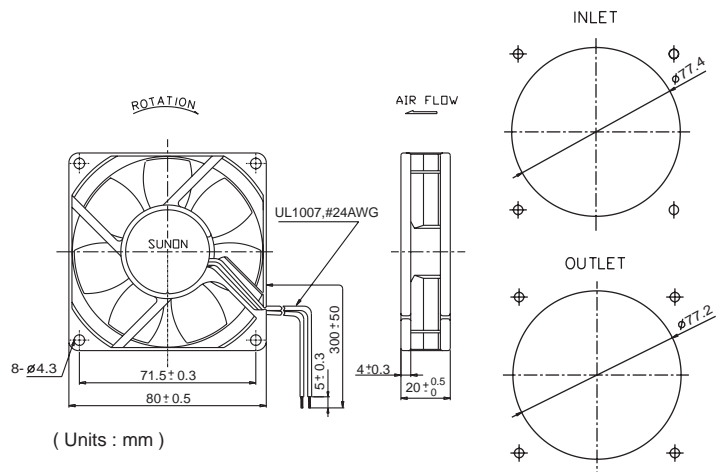
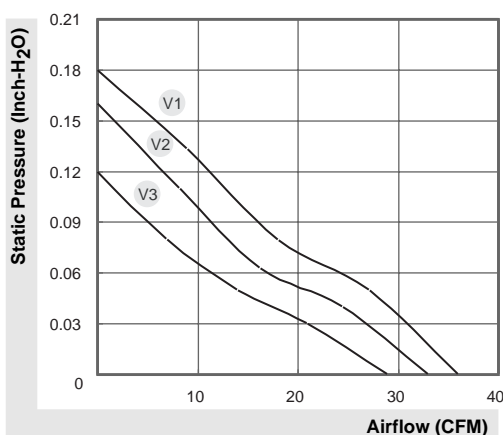

\*All model could be customized on voltage or any other requirements to fit your need.

\*Specifications subject to change without notice. Please Visit SUNON web site at <http://www.sunon.com> for update information.

## MagLev Motor Fan

### 31~40 CFM



Model	P/N	Bearing ● VAPO ● 2BALL	Rating Voltage (VDC)	Power Current (AMP)	Power Consumption (WATTS)	Speed (RPM)	Air Flow (CFM)	Static Pressure (Inch-H <sub>2</sub> O)	Noise (dBA)	Weight (g)
KDE1208PTV1	13.MS.A.GN	●	12	0.13	1.6	3000	40.0	0.18	33	80
KDE1208PTV2	13.MS.A.GN	●	12	0.10	1.2	2700	36.5	0.15	31	80
KDE1208PTV3	13.MS.A.GN	●	12	0.07	0.8	2300	31.0	0.11	26	80
KDE2408PTV1	13.MS.A.GN	●	24	0.07	1.7	3000	40.0	0.18	33	83
KDE2408PTV2	13.MS.A.GN	●	24	0.06	1.4	2700	36.5	0.15	31	83
KDE2408PTV3	13.MS.A.GN	●	24	0.04	1.0	2300	31.0	0.11	26	83

\*High air flow products please see page 46.

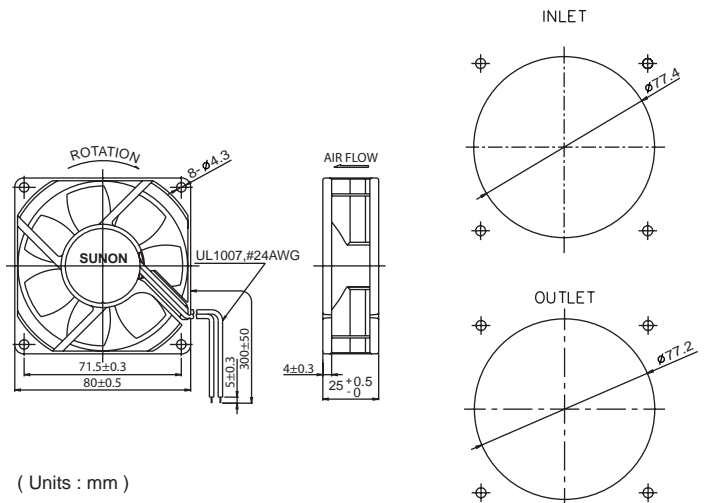
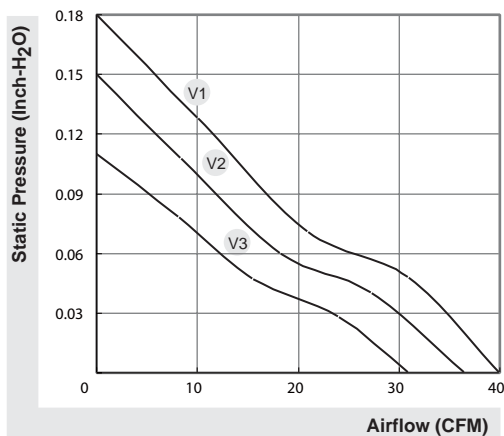

\*All model could be customized on voltage or any other requirements to fit your need.

\*Specifications subject to change without notice. Please Visit SUNON web site at <http://www.sunon.com> for update information.



# 92X92X25 mm

# SUNON

## MagLev Motor Fan

## 39~49 CFM



Model	P/N	Bearing ● VAPO ⊙ 2BALL	Rating Voltage (VDC)	Power Current (AMP)	Power Consumption (WATTS)	Speed (RPM)	Air Flow (CFM)	Static Pressure (Inch-H <sub>2</sub> O)	Noise (dBA)	Weight (g)
KDE1209PTV1	13.MS.A.GN	●	12	0.15	1.8	2800	49.0	0.16	34	95
KDE1209PTV2	13.MS.A.GN	●	12	0.12	1.4	2500	44.5	0.14	32	95
KDE1209PTV3	13.MS.A.GN	●	12	0.08	1.0	2200	39.0	0.11	28	95
KDE2409PTV1	13.MS.A.GN	●	24	0.08	1.9	2800	49.0	0.16	34	100
KDE2409PTV2	13.MS.A.GN	●	24	0.06	1.4	2500	44.5	0.14	32	100
KDE2409PTV3	13.MS.A.GN	●	24	0.05	1.2	2200	39.0	0.11	28	100

\*High air flow products please see page 48.

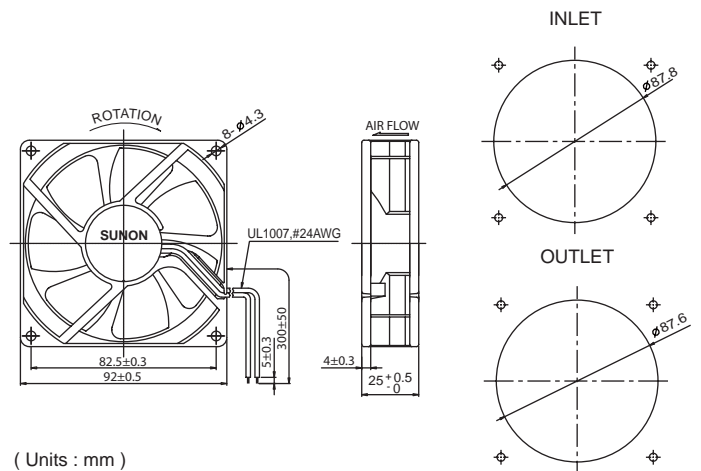
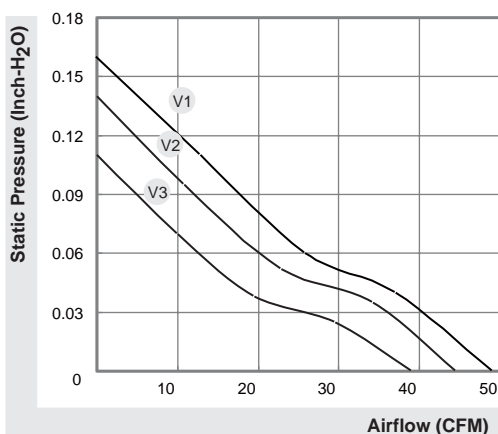

\*All model could be customized on voltage or any other requirements to fit your need.

\*Specifications subject to change without notice. Please Visit SUNON web site at <http://www.sunon.com> for update information.

# 120X120X38 mm

# SUNON

## MagLev Motor Fan

## 113~145 CFM



Model	P/N	Bearing ● VAPO ⊙ 2BALL	Rating Voltage (VDC)	Power Current (AMP)	Power Consumption (WATTS)	Speed (RPM)	Air Flow (CFM)	Static Pressure (Inch-H <sub>2</sub> O)	Noise (dBA)	Weight (g)
KDE1212PMV1	13.MS.A.GN	●	12	0.853	10.2	3000	145	0.32	50	300
KDE1212PMV2	13.MS.A.GN	●	12	0.655	7.9	2700	128	0.25	46	300
KDE1212PMV3	13.MS.A.GN	●	12	0.481	5.8	2400	113	0.20	43	300
KDE2412PMV1	13.MS.A.GN	●	24	0.413	9.9	3000	145	0.32	50	300
KDE2412PMV2	13.MS.A.GN	●	24	0.312	7.5	2700	128	0.25	46	300
KDE2412PMV3	13.MS.A.GN	●	24	0.239	5.7	2400	113	0.20	43	300
KDE4812PMV1	13.MS.A.GN	●	48	0.225	10.8	3000	145	0.32	50	300
KDE4812PMV2	13.MS.A.GN	●	48	0.168	8.1	2700	128	0.25	46	300
KDE4812PMV3	13.MS.A.GN	●	48	0.128	6.1	2400	113	0.20	43	300

\*High air flow products please see page 51.

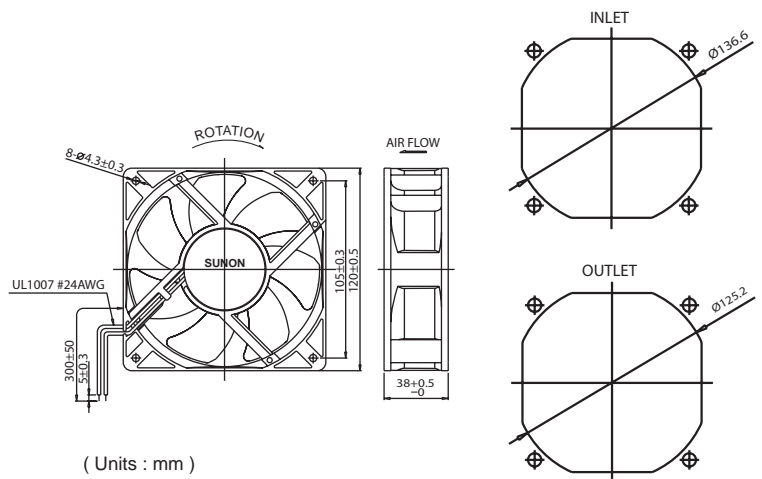
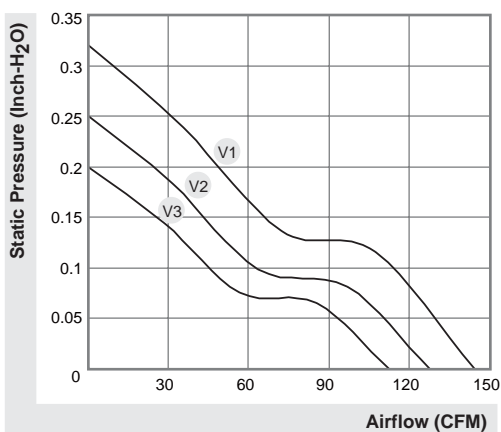

\*All model could be customized on voltage or any other requirements to fit your need.

\*Specifications subject to change without notice. Please Visit SUNON web site at <http://www.sunon.com> for update information.



MagLev Power Motor Fan  
Power Motor Fan



# 38x38x20 mm

# SUNON

Power Motor Fan

10.6~13.5 CFM



Model	P/N	Bearing ● VAPO ⊕ 2BALL	Rating Voltage (VDC)	Power Current (AMP)	Power Consumption (WATTS)	Speed (RPM)	Air Flow (CFM)	Static Pressure (Inch-H <sub>2</sub> O)	Noise (dBA)	Weight (g)
PMD1238PKBX-A	(2).GN	⊕	12	0.36	4.3	15000	13.5	0.82	48.0	27
PMD1238PKB1-A	(2).GN	⊕	12	0.26	3.1	13000	12.0	0.61	44.0	27
PMD1238PKB2-A	(2).GN	⊕	12	0.21	2.5	11000	10.6	0.45	39.0	27

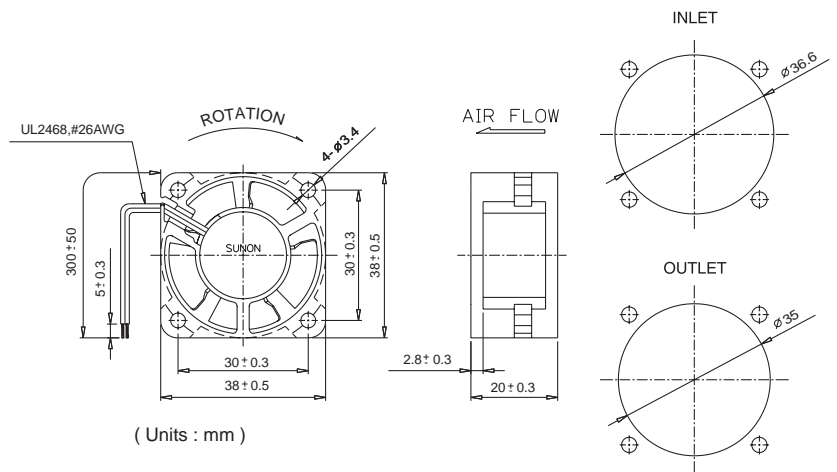
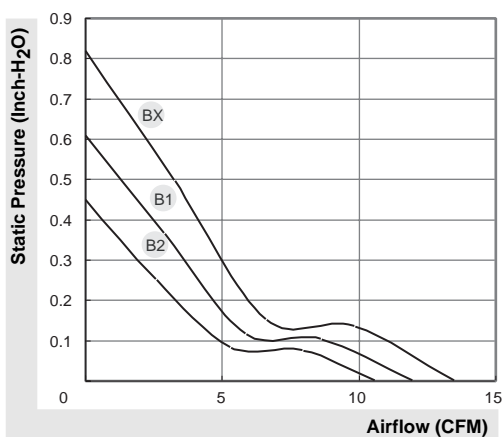

\*All model could be customized on voltage or any other requirements to fit your need.

\*Specifications subject to change without notice. Please Visit SUNON web site at <http://www.sunon.com> for update information

# 38x38x28 mm

# SUNON

Power Motor Fan

12.6~19.0 CFM



Model	P/N	Bearing ● VAPO ⊕ 2BALL	Rating Voltage (VDC)	Power Current (AMP)	Power Consumption (WATTS)	Speed (RPM)	Air Flow (CFM)	Static Pressure (Inch-H <sub>2</sub> O)	Noise (dBA)	Weight (g)
PMD1238PQBX-A	(2).GN	⊕	12	0.48	5.8	15000	19.0	1.20	52.0	35.2
PMD1238PQB1-A	(2).GN	⊕	12	0.30	3.6	13000	16.5	0.91	47.0	35.2
PMD1238PQB2-A	(2).GN	⊕	12	0.19	2.3	10000	12.6	0.55	42.0	35.2

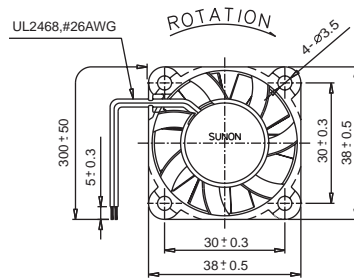
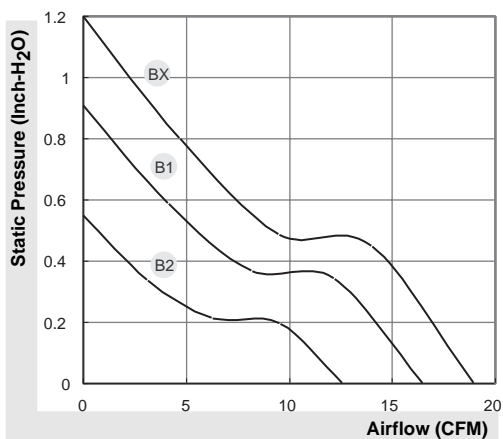

(Units : mm)

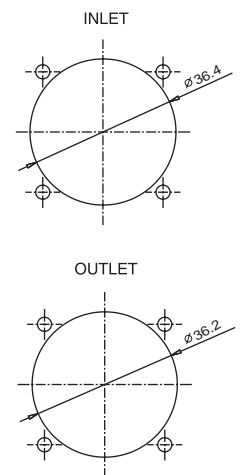
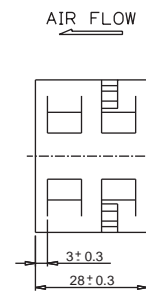

\*All model could be customized on voltage or any other requirements to fit your need.

\*Specifications subject to change without notice. Please Visit SUNON web site at <http://www.sunon.com> for update information.

# 40x40x24 mm

# SUNON

Power Motor Fan

17.6~23.5 CFM



Model	P/N	Bearing ● VAPO ⊙ 2BALL	Rating Voltage (VDC)	Power Current (AMP)	Power Consumption (WATTS)	Speed (RPM)	Air Flow (CFM)	Static Pressure (Inch-H <sub>2</sub> O)	Noise (dBA)	Weight (g)
PMD1204PBB1-A	(2).GN	⊙	12	0.78	9.4	14500	23.5	1.26	55.0	41.6
PMD1204PBB2-A	(2).GN	⊙	12	0.57	6.8	13000	21.5	0.96	52.0	41.6
PMD1204PBB3-A	(2).GN	⊙	12	0.39	4.7	11000	17.6	0.68	47.0	40.5

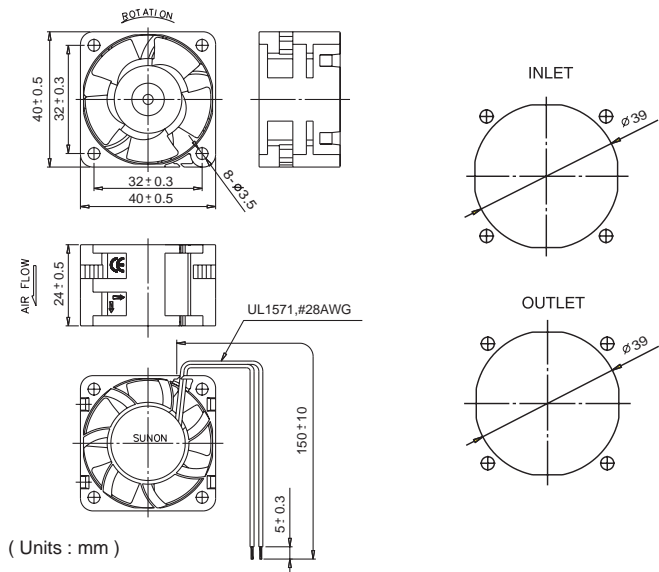
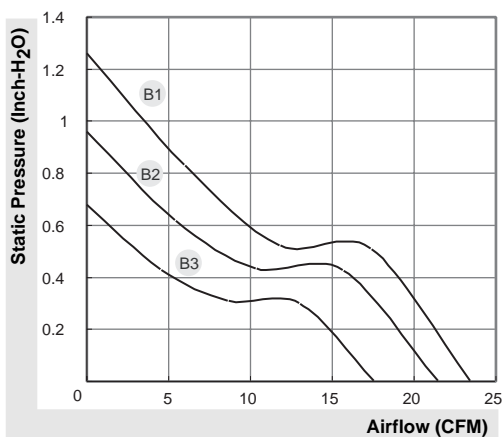

\*All model could be customized on voltage or any other requirements to fit your need.

\*Specifications subject to change without notice. Please Visit SUNON web site at <http://www.sunon.com> for update information.

# 40x40x28 mm

# SUNON

Power Motor Fan

18.5~24 CFM



Model	P/N	Bearing	Rating Voltage (VDC)	Power Current (AMP)	Power Consumption (WATTS)	Speed (RPM)	Air Flow (CFM)	Static Pressure (Inch-H <sub>2</sub> O)	Noise (dBA)	Weight (g)
PMD1204PQB1-A	(2).U.GN	● VAPO ⊙ 2BALL	12	0.72	8.6	15000	24.0	1.34	55.5	46
PMD1204PQV2-A	U.GN	●	12	0.57	6.8	13000	18.5	1.10	53	46

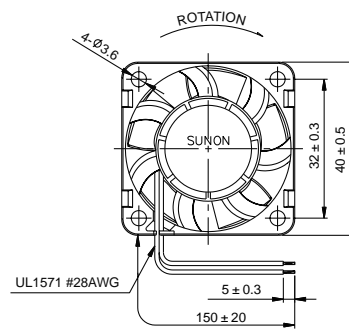
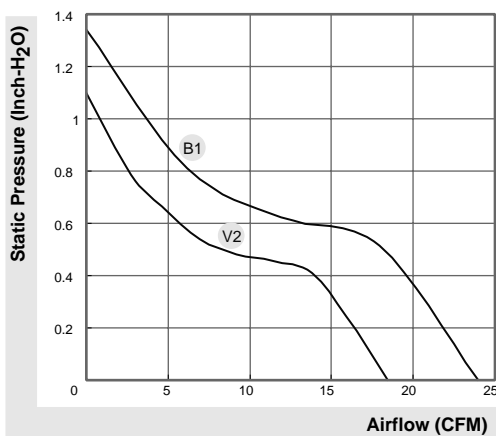

( Units : mm )

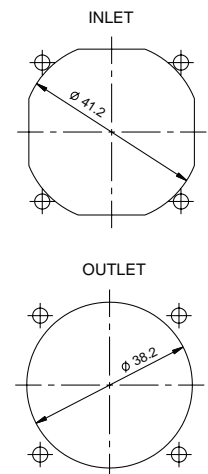
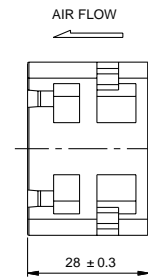

\*All model could be customized on voltage or any other requirements to fit your need.

\*Specifications subject to change without notice. Please Visit SUNON web site at <http://www.sunon.com> for update information.

# 40x40x56 mm

# SUNON

Power Motor Fan

25~26.5 CFM



Model	P/N	Bearing	Rating Voltage (VDC)	Power Current (AMP)	Power Consumption (WATTS)	Speed (RPM)	Air Flow (CFM)	Static Pressure (Inch-H <sub>2</sub> O)	Noise (dBA)	Weight (g)
PMD1204PPB1-A	(2).GN	● VAPO ⊙ 2BALL	12	1.4	16.8	14500/9500	26.5	1.73	59	88.4
PMD1204PPB2-A	(2).GN	⊙ 2BALL	12	1.1	13.2	13000/9500	25.0	1.50	58	88.2
PMD1204PPB3-A	(2).GN	⊙ 2BALL	12	0.71	8.5	11000/8000	21.2	1.12	55.1	82.0

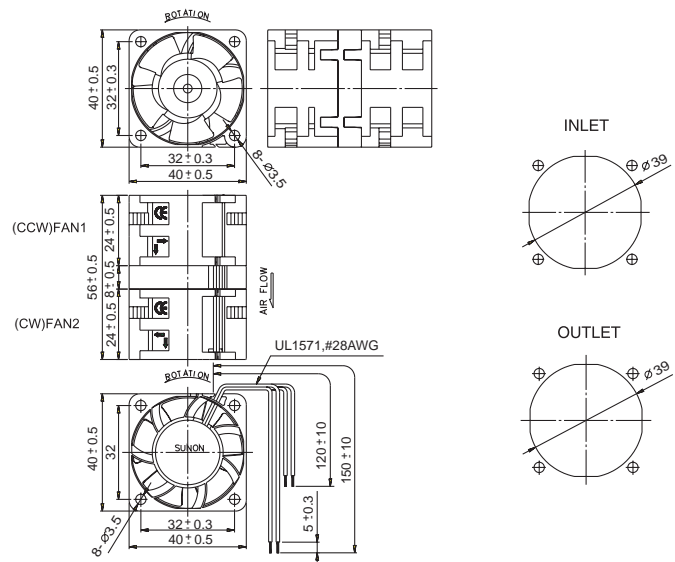
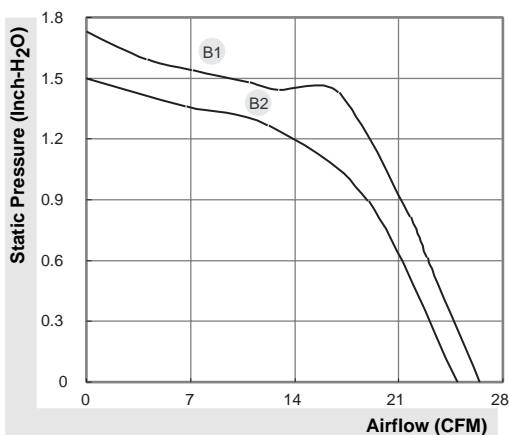

( Units : mm )

\*All model could be customized on voltage or any other requirements to fit your need.

\*Specifications subject to change without notice. Please Visit SUNON web site at <http://www.sunon.com> for update information



# 60x60x20 mm

# SUNON

## MagLev Power Motor Fan

## 19.5~30.5 CFM



Model	P/N	Bearing ● VAPO ⊙ 2BALL	Rating Voltage (VDC)	Power Current (AMP)	Power Consumption (WATTS)	Speed (RPM)	Air Flow (CFM)	Static Pressure (Inch-H <sub>2</sub> O)	Noise (dBA)	Weight (g)
PMD1206PKVX-A	GN	●	12	0.275	3.3	5500	30.5	0.35	40	55
PMD1206PKV1-A	GN	●	12	0.228	2.7	5000	27.5	0.28	38	55
PMD1206PKV2-A	GN	●	12	0.18	2.2	4400	23.5	0.20	34	55
PMD1206PKV3-A	GN	●	12	0.122	1.5	3600	19.5	0.15	29	55
PMD1206PKBX-A	(2).GN	⊙	12	0.274	3.3	5500	30.5	0.35	41	55
PMD1206PKB1-A	(2).GN	⊙	12	0.22	2.6	5000	27.5	0.28	39	55
PMD1206PKB2-A	(2).GN	⊙	12	0.181	2.2	4400	23.5	0.20	35	55
PMD1206PKB3-A	(2).GN	⊙	12	0.118	1.4	3600	19.5	0.15	30	55
PMD2406PKVX-A	GN	●	24	0.157	3.8	5500	30.5	0.35	40	55
PMD2406PKV1-A	GN	●	24	0.125	3.0	5000	27.5	0.28	38	55
PMD2406PKV2-A	GN	●	24	0.1	2.4	4400	23.5	0.20	34	55
PMD2406PKV3-A	GN	●	24	0.072	1.7	3600	19.5	0.15	29	55
PMD2406PKBX-A	(2).GN	⊙	24	0.151	3.6	5500	30.5	0.35	41	55
PMD2406PKB1-A	(2).GN	⊙	24	0.122	2.9	5000	27.5	0.28	39	55
PMD2406PKB2-A	(2).GN	⊙	24	0.098	2.4	4400	23.5	0.20	35	55
PMD2406PKB3-A	(2).GN	⊙	24	0.072	1.7	3600	19.5	0.15	30	55

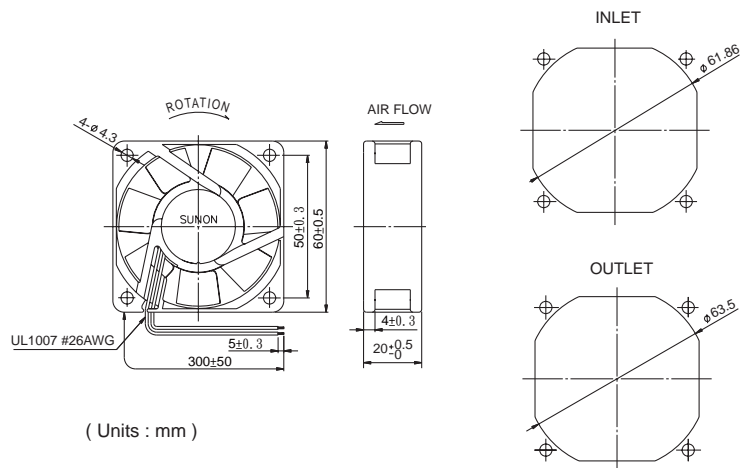
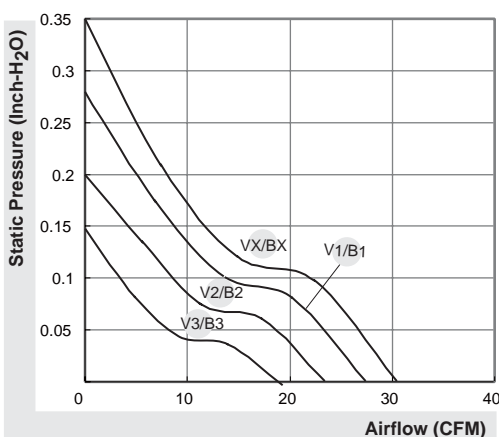

\*All model could be customized on voltage or any other requirements to fit your need.

\*Specifications subject to change without notice. Please Visit SUNON web site at <http://www.sunon.com> for update information.

# 60x60x25 mm

# SUNON

## MagLev Power Motor Fan

## 29~40 CFM



Model	P/N	Bearing	Rating Voltage (VDC)	Power Current (AMP)	Power Consumption (WATTS)	Speed (RPM)	Air Flow (CFM)	Static Pressure (Inch-H <sub>2</sub> O)	Noise (dBA)	Weight (g)
PMD1206PTVX-A	U.GN	●	12	0.446	5.4	7600	40.0	0.64	45	75
PMD1206PTV1-A	U.GN	●	12	0.357	4.3	6900	36.0	0.54	43	75
PMD1206PTV2-A	U.GN	●	12	0.269	3.2	6100	31.5	0.42	41	75
PMD1206PTV3-A	U.GN	●	12	0.235	2.8	5600	29.0	0.36	37	75
PMD1206PTBX-A	(2).U.GN	⊙	12	0.41	4.9	7600	40.0	0.64	46	75
PMD1206PTB1-A	(2).U.GN	⊙	12	0.325	3.9	6900	36.0	0.54	44	75
PMD1206PTB2-A	(2).U.GN	⊙	12	0.258	3.1	6100	31.5	0.42	42	75
PMD1206PTB3-A	(2).U.GN	⊙	12	0.217	2.6	5600	29.0	0.36	38	75
PMD2406PTVX-A	U.GN	●	24	0.207	5.0	7600	40.0	0.64	45	75
PMD2406PTV1-A	U.GN	●	24	0.181	4.3	6900	36.0	0.54	43	75
PMD2406PTV2-A	U.GN	●	24	0.131	3.1	6100	31.5	0.42	41	75
PMD2406PTV3-A	U.GN	●	24	0.114	2.7	5600	29.0	0.36	37	75
PMD2406PTBX-A	(2).U.GN	⊙	24	0.197	4.7	7600	40.0	0.64	46	75
PMD2406PTB1-A	(2).U.GN	⊙	24	0.158	3.8	6900	36.0	0.54	44	75
PMD2406PTB2-A	(2).U.GN	⊙	24	0.121	2.9	6100	31.5	0.42	42	75
PMD2406PTB3-A	(2).U.GN	⊙	24	0.104	2.5	5600	29.0	0.36	38	75
PMD4806PTVX-A	U.GN	●	48	0.114	5.5	7600	40.0	0.64	45	75
PMD4806PTV1-A	U.GN	●	48	0.099	4.8	6900	36.0	0.54	43	75
PMD4806PTV2-A	U.GN	●	48	0.078	3.7	6100	31.5	0.42	41	75
PMD4806PTV3-A	U.GN	●	48	0.069	3.3	5600	29.0	0.36	37	75
PMD4806PTBX-A	(2).U.GN	⊙	48	0.112	5.4	7600	40.0	0.64	46	75
PMD4806PTB1-A	(2).U.GN	⊙	48	0.09	4.3	6900	36.0	0.54	44	75
PMD4806PTB2-A	(2).U.GN	⊙	48	0.072	3.5	6100	31.5	0.42	42	75
PMD4806PTB3-A	(2).U.GN	⊙	48	0.068	3.3	5600	29.0	0.36	38	75

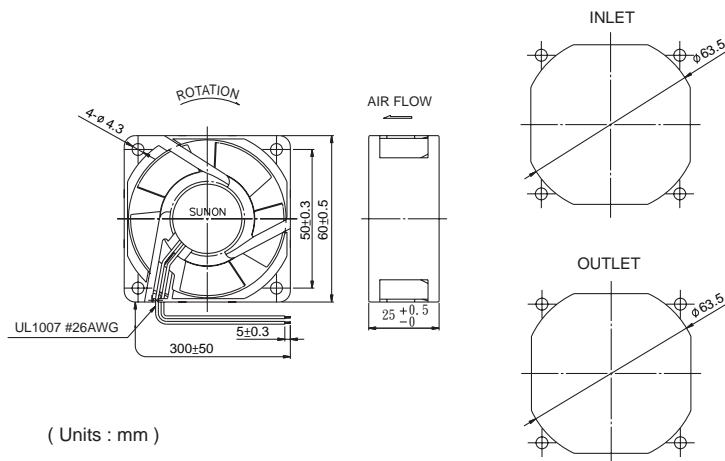
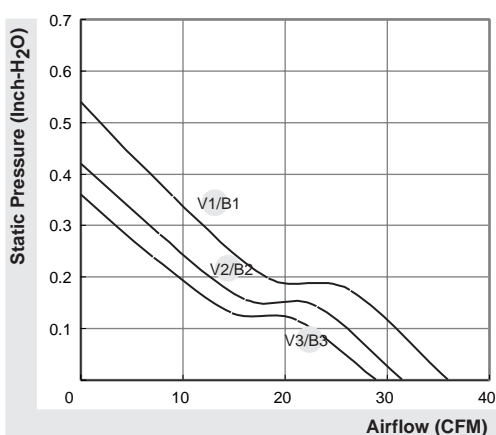

\*All model could be customized on voltage or any other requirements to fit your need.

\*Specifications subject to change without notice. Please Visit SUNON web site at <http://www.sunon.com> for update information.

# 60x60x38 mm

# SUNON

Power Motor Fan

41.5~56.5 CFM



Model	P/N	Bearing ● VAPO ⊙ 2BALL	Rating Voltage (VDC)	Power Current (AMP)	Power Consumption (WATTS)	Speed (RPM)	Air Flow (CFM)	Static Pressure (Inch-H <sub>2</sub> O)	Noise (dBA)	Weight (g)
PMD1206PMB1-A	(2).GN	⊙	12	0.88	10.6	8000	56.5	0.92	56	90
PMD1206PMB2-A	(2).GN	⊙	12	0.58	7.0	7000	49.2	0.71	52	90
PMD1206PMB3-A	(2).GN	⊙	12	0.43	5.2	6000	41.5	0.53	47	90
PMD2406PMB1-A	(2).GN	⊙	24	0.43	10.3	8000	56.5	0.92	56	90
PMD2406PMB2-A	(2).GN	⊙	24	0.31	7.4	7000	49.2	0.71	52	90
PMD2406PMB3-A	(2).GN	⊙	24	0.22	5.3	6000	41.5	0.53	47	90
PMD4806PMB1-A	(2).GN	⊙	48	0.24	11.5	8000	56.5	0.92	56	90
PMD4806PMB2-A	(2).GN	⊙	48	0.18	8.6	7000	49.2	0.71	52	90
PMD4806PMB3-A	(2).GN	⊙	48	0.13	6.2	6000	41.5	0.53	47	90

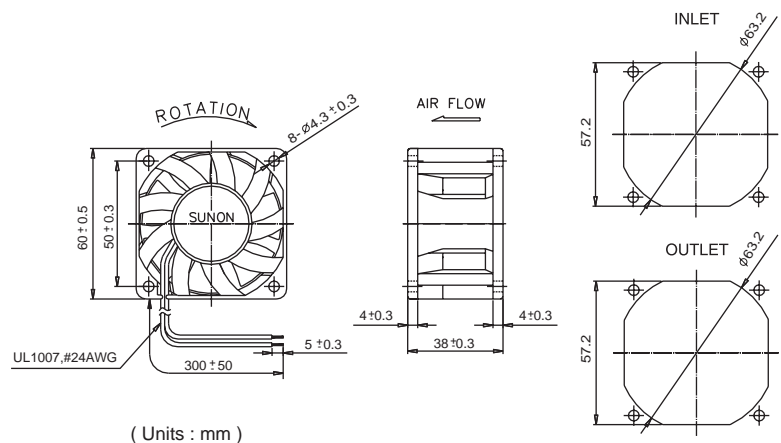
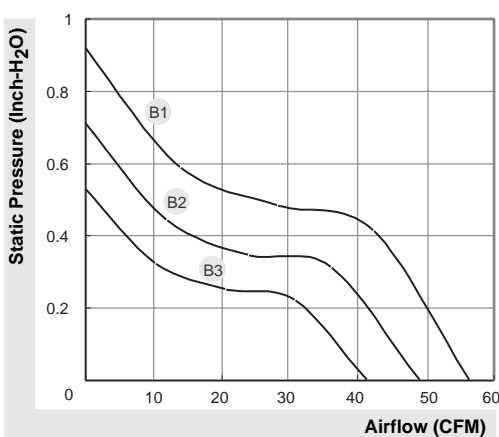

\*All model could be customized on voltage or any other requirements to fit your need.

\*Specifications subject to change without notice. Please Visit SUNON web site at <http://www.sunon.com> for update information.

# 70x70x20 mm

# SUNON

## MagLev Power Motor Fan

## 37~43 CFM



Model	P/N	Bearing ● VAPO ⊕ 2BALL	Rating Voltage (VDC)	Power Current (AMP)	Power Consumption (WATTS)	Speed (RPM)	Air Flow (CFM)	Static Pressure (Inch-H <sub>2</sub> O)	Noise (dBA)	Weight (g)
PMD1207PKV1-A	GN	●	12	0.39	4.7	4600	43	0.28	41.5	80
PMD1207PKV2-A	GN	●	12	0.31	3.7	4300	40	0.24	40.0	80
PMD1207PKV3-A	GN	●	12	0.26	3.1	4000	37	0.21	37.5	80
PMD1207PKB1-A	(2).GN	⊕	12	0.39	4.7	4600	43	0.28	42.5	80
PMD1207PKB2-A	(2).GN	⊕	12	0.31	3.7	4300	40	0.24	41.0	80
PMD1207PKB3-A	(2).GN	⊕	12	0.26	3.1	4000	37	0.21	38.5	80
PMD2407PKV1-A	GN	●	24	0.21	5.0	4600	43	0.28	41.5	80
PMD2407PKV2-A	GN	●	24	0.17	4.1	4300	40	0.24	40.0	80
PMD2407PKV3-A	GN	●	24	0.14	3.4	4000	37	0.21	37.5	80
PMD2407PKB1-A	(2).GN	⊕	24	0.21	5.0	4600	43	0.28	42.5	80
PMD2407PKB2-A	(2).GN	⊕	24	0.17	4.1	4300	40	0.24	41.0	80
PMD2407PKB3-A	(2).GN	⊕	48	0.14	3.4	4000	37	0.21	38.5	80

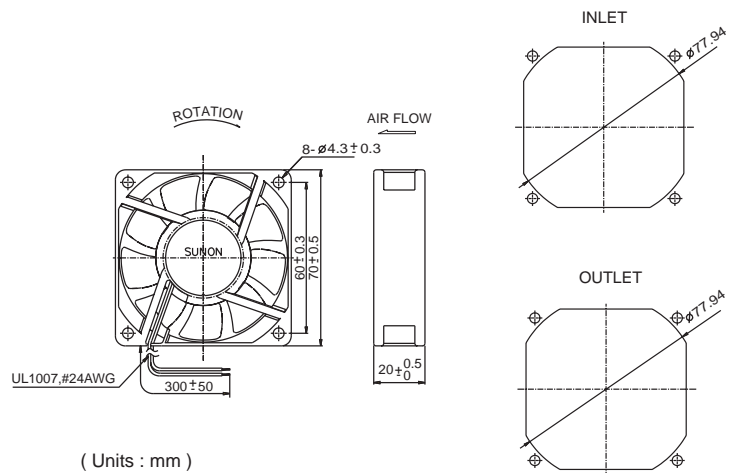
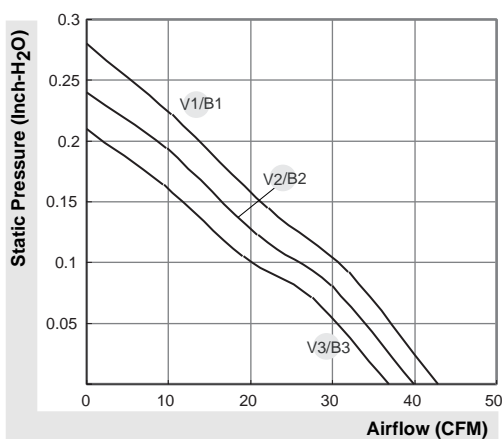

\*All model could be customized on voltage or any other requirements to fit your need.

\*Specifications subject to change without notice. Please Visit SUNON web site at <http://www.sunon.com> for update information.

# 70X70X25 mm

# SUNON

## MagLev Power Motor Fan

### 40~49 CFM



Model	P/N	Bearing ● VAPO ⊕ 2BALL	Rating Voltage (VDC)	Power Current (AMP)	Power Consumption (WATTS)	Speed (RPM)	Air Flow (CFM)	Static Pressure (Inch-H <sub>2</sub> O)	Noise (dBA)	Weight (g)
PMD1207PTV1-A	GN	●	12	0.37	4.4	5100	49	0.36	44	90
PMD1207PTV2-A	GN	●	12	0.32	3.8	4700	45	0.31	42	90
PMD1207PTV3-A	GN	●	12	0.25	3.0	4200	40	0.25	38	90
PMD1207PTB1-A	(2).GN	⊕	12	0.37	4.4	5100	49	0.36	45	90
PMD1207PTB2-A	(2).GN	⊕	12	0.31	3.7	4700	45	0.31	43	90
PMD1207PTB3-A	(2).GN	⊕	12	0.24	2.9	4200	40	0.25	39	90
PMD2407PTV1-A	GN	●	24	0.20	4.8	5100	49	0.36	44	90
PMD2407PTV2-A	GN	●	24	0.16	3.8	4700	45	0.31	42	90
PMD2407PTV3-A	GN	●	24	0.13	3.1	4200	40	0.25	38	90
PMD2407PTB1-A	(2).GN	⊕	24	0.19	4.6	5100	49	0.36	45	90
PMD2407PTB2-A	(2).GN	⊕	24	0.15	3.6	4700	45	0.31	43	90
PMD2407PTB3-A	(2).GN	⊕	24	0.12	2.9	4200	40	0.25	39	90
PMD4807PTV1-A	GN	●	48	0.12	5.8	5100	49	0.36	44	90
PMD4807PTV2-A	GN	●	48	0.11	5.3	4700	45	0.31	42	90
PMD4807PTV3-A	GN	●	48	0.09	4.3	4200	40	0.25	38	90
PMD4807PTB1-A	(2).GN	⊕	48	0.12	5.8	5100	49	0.36	45	90
PMD4807PTB2-A	(2).GN	⊕	48	0.10	4.8	4700	45	0.31	43	90
PMD4807PTB3-A	(2).GN	⊕	48	0.08	4.3	4200	40	0.25	39	90

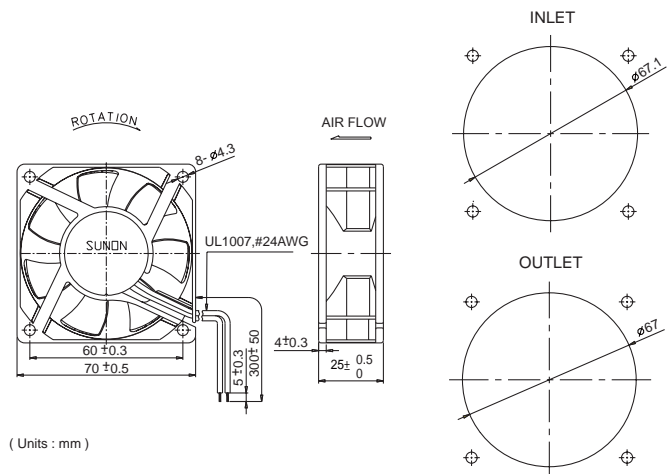
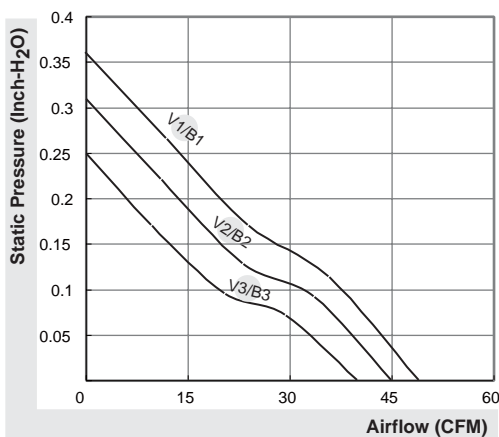

\*All model could be customized on voltage or any other requirements to fit your need.

\*Specifications subject to change without notice. Please Visit SUNON web site at <http://www.sunon.com> for update information.

# 80x80x20 mm

# SUNON

## MagLev Power Motor Fan

### 45~53 CFM



Model	P/N	Bearing ● VAPO ⊕ 2BALL	Rating Voltage (VDC)	Power Current (AMP)	Power Consumption (WATTS)	Speed (RPM)	Air Flow (CFM)	Static Pressure (Inch-H <sub>2</sub> O)	Noise (dBA)	Weight (g)
PMD1208PKV1-A	GN	●	12	0.39	4.7	4600	53	0.36	48	85
PMD1208PKV2-A	GN	●	12	0.31	3.7	4200	49	0.31	45	85
PMD1208PKV3-A	GN	●	12	0.26	3.1	3900	45	0.26	43	85
PMD1208PKB1-A	(2).GN	⊕	12	0.39	4.7	4600	53	0.36	49	85
PMD1208PKB2-A	(2).GN	⊕	12	0.31	3.7	4200	49	0.31	46	85
PMD1208PKB3-A	(2).GN	⊕	12	0.26	3.1	3900	45	0.26	44	85
PMD2408PKV1-A	GN	●	24	0.21	5.0	4600	53	0.36	48	85
PMD2408PKV2-A	GN	●	24	0.17	4.1	4200	49	0.31	45	85
PMD2408PKV3-A	GN	●	24	0.14	3.4	3900	45	0.26	43	85
PMD2408PKB1-A	(2).GN	⊕	24	0.21	5.0	4600	53	0.36	49	85
PMD2408PKB2-A	(2).GN	⊕	24	0.17	4.1	4200	49	0.31	46	85
PMD2408PKB3-A	(2).GN	⊕	24	0.14	3.4	3900	45	0.26	44	85

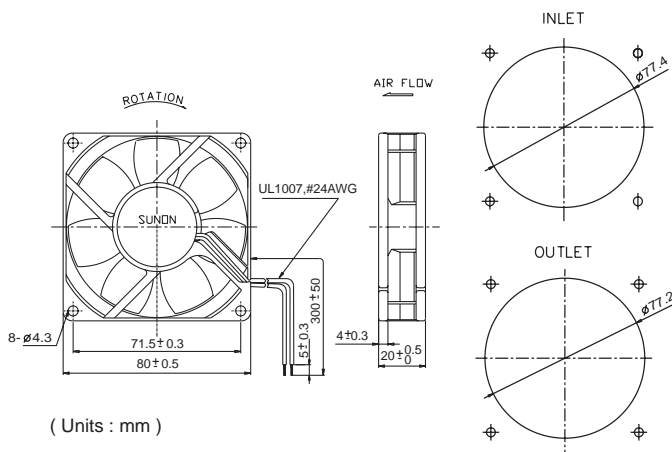
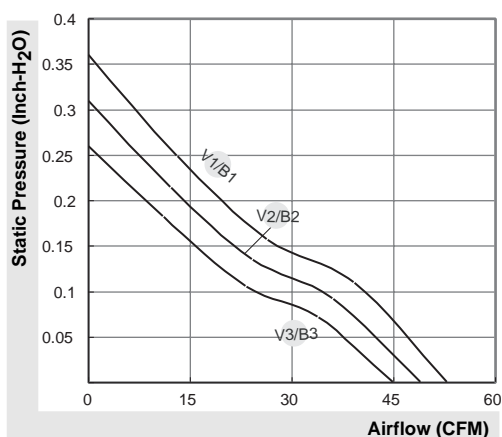

\*All model could be customized on voltage or any other requirements to fit your need.

\*Specifications subject to change without notice. Please Visit SUNON web site at <http://www.sunon.com> for update information.

# 80x80x25 mm

# SUNON

## MagLev Power Motor Fan

## 49~60 CFM



Model	P/N	Bearing ● VAPO ⊙ 2BALL	Rating Voltage (VDC)	Power Current (AMP)	Power Consumption (WATTS)	Speed (RPM)	Air Flow (CFM)	Static Pressure (Inch-H <sub>2</sub> O)	Noise (dBA)	Weight (g)
PMD1208PTV1-A	GN	●	12	0.42	5.0	4700	60	0.43	46	100
PMD1208PTV2-A	GN	●	12	0.34	4.1	4300	55	0.36	44	100
PMD1208PTV3-A	GN	●	12	0.27	3.2	3900	49	0.30	41	100
PMD1208PTB1-A	(2).GN	⊙	12	0.40	4.8	4700	60	0.43	47	100
PMD1208PTB2-A	(2).GN	⊙	12	0.34	4.1	4300	55	0.36	45	100
PMD1208PTB3-A	(2).GN	⊙	12	0.26	3.1	3900	49	0.30	42	100
PMD2408PTV1-A	GN	●	24	0.22	5.3	4700	60	0.43	46	100
PMD2408PTV2-A	GN	●	24	0.17	4.1	4300	55	0.36	44	100
PMD2408PTV3-A	GN	●	24	0.14	3.4	3900	49	0.30	41	100
PMD2408PTB1-A	(2).GN	⊙	24	0.21	5.0	4700	60	0.43	47	100
PMD2408PTB2-A	(2).GN	⊙	24	0.17	4.1	4300	55	0.36	45	100
PMD2408PTB3-A	(2).GN	⊙	24	0.13	3.1	3900	49	0.30	42	100
PMD4808PTV1-A	GN	●	48	0.13	6.2	4700	60	0.43	46	100
PMD4808PTV2-A	GN	●	48	0.11	5.3	4300	55	0.36	44	100
PMD4808PTV3-A	GN	●	48	0.09	4.3	3900	49	0.30	41	100
PMD4808PTB1-A	(2).GN	⊙	48	0.13	6.2	4700	60	0.43	47	100
PMD4808PTB2-A	(2).GN	⊙	48	0.11	5.3	4300	55	0.36	45	100
PMD4808PTB3-A	(2).GN	⊙	48	0.09	4.3	3900	49	0.30	42	100

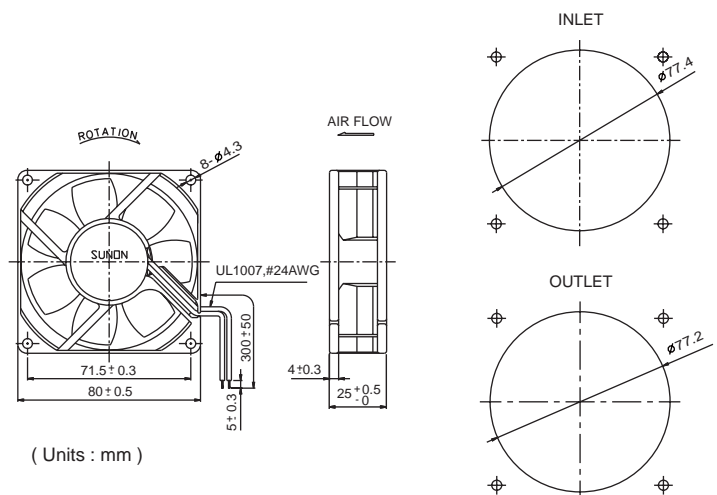
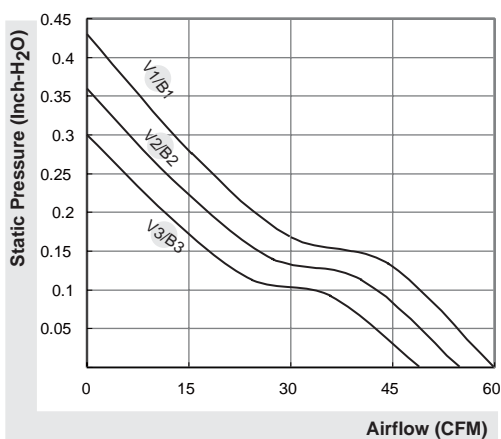

\*All model could be customized on voltage or any other requirements to fit your need.

\*Specifications subject to change without notice. Please Visit SUNON web site at <http://www.sunon.com> for update information.

# 80x80x38 mm

# SUNON

Power Motor Fan

59.5~84.1 CFM



Model	P/N	Bearing ● VAPO ⊕ 2BALL	Rating Voltage (VDC)	Power Current (AMP)	Power Consumption (WATTS)	Speed (RPM)	Air Flow (CFM)	Static Pressure (Inch-H <sub>2</sub> O)	Noise (dBA)	Weight (g)
PMD1208PMB1-A	(2).GN	⊕	12	0.76	9.1	5700	84.1	0.74	55.2	175
PMD1208PMB2-A	(2).GN	⊕	12	0.53	6.4	4900	74.5	0.57	51.6	175
PMD1208PMB3-A	(2).GN	⊕	12	0.37	4.4	4200	59.5	0.43	47.3	175
PMD2408PMB1-A	(2).GN	⊕	24	0.40	9.6	5700	84.1	0.74	55.2	175
PMD2408PMB2-A	(2).GN	⊕	24	0.30	7.2	4900	74.5	0.57	51.6	175
PMD2408PMB3-A	(2).GN	⊕	24	0.20	4.8	4200	59.5	0.43	47.3	175
PMD4808PMB1-A	(2).GN	⊕	48	0.19	9.1	5700	84.1	0.74	55.2	175
PMD4808PMB2-A	(2).GN	⊕	48	0.14	6.7	4900	74.5	0.57	51.6	175
PMD4808PMB3-A	(2).GN	⊕	48	0.10	4.8	4200	59.5	0.43	47.3	175

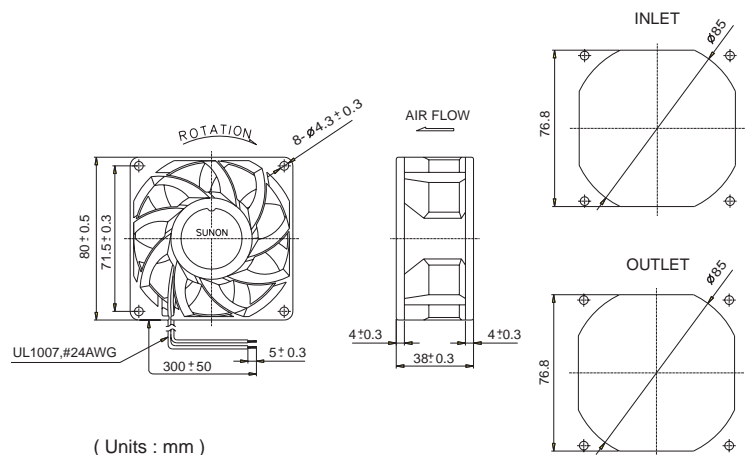
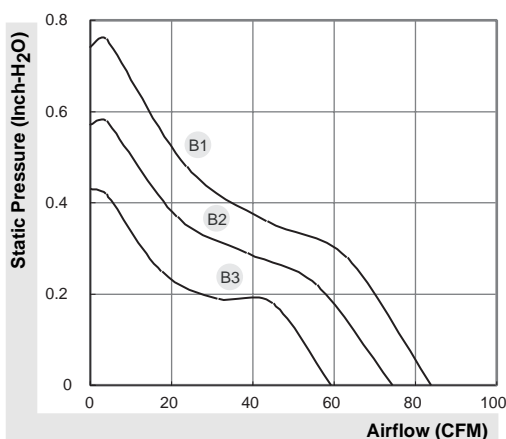

\*All model could be customized on voltage or any other requirements to fit your need.

\*Specifications subject to change without notice. Please Visit SUNON web site at <http://www.sunon.com> for update information.



# 92X92X25 mm

# SUNON

## MagLev Power Motor Fan

## 65~77 CFM



Model	P/N	Bearing ● VAPO ⊕ 2BALL	Rating Voltage (VDC)	Power Current (AMP)	Power Consumption (WATTS)	Speed (RPM)	Air Flow (CFM)	Static Pressure (Inch-H <sub>2</sub> O)	Noise (dBA)	Weight (g)
PMD1209PTV1-A	GN	●	12	0.47	5.6	4200	77	0.37	47	120
PMD1209PTV2-A	GN	●	12	0.40	4.8	3900	73	0.33	44	120
PMD1209PTV3-A	GN	●	12	0.31	3.7	3600	65	0.28	42	120
PMD1209PTB1-A	(2).GN	⊕	12	0.46	5.5	4200	77	0.37	48	120
PMD1209PTB2-A	(2).GN	⊕	12	0.38	4.6	3900	73	0.33	45	120
PMD1209PTB3-A	(2).GN	⊕	12	0.30	3.6	3600	65	0.28	43	120
PMD2409PTV1-A	GN	●	24	0.25	6.0	4200	77	0.37	47	120
PMD2409PTV2-A	GN	●	24	0.20	4.8	3900	73	0.33	44	120
PMD2409PTV3-A	GN	●	24	0.16	3.8	3600	65	0.28	42	120
PMD2409PTB1-A	(2).GN	⊕	24	0.24	5.8	4200	77	0.37	48	120
PMD2409PTB2-A	(2).GN	⊕	24	0.19	4.6	3900	73	0.33	45	120
PMD2409PTB3-A	(2).GN	⊕	24	0.15	3.6	3600	65	0.28	43	120
PMD4809PTV1-A	GN	●	48	0.15	7.2	4200	77	0.37	47	120
PMD4809PTV2-A	GN	●	48	0.12	5.8	3900	73	0.33	44	120
PMD4809PTV3-A	GN	●	48	0.09	4.3	3600	65	0.28	42	120
PMD4809PTB1-A	(2).GN	⊕	48	0.14	6.7	4200	77	0.37	48	120
PMD4809PTB2-A	(2).GN	⊕	48	0.12	5.8	3900	73	0.33	45	120
PMD4809PTB3-A	(2).GN	⊕	48	0.09	4.3	3600	65	0.28	43	120

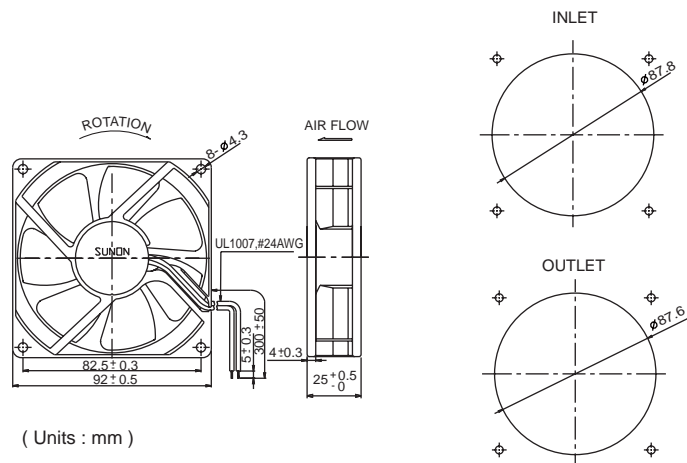
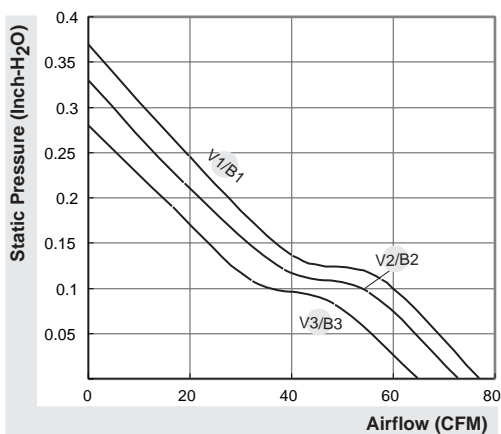

\*All model could be customized on voltage or any other requirements to fit your need.

\*Specifications subject to change without notice. Please Visit SUNON web site at <http://www.sunon.com> for update information.

# 92x92x38 mm

# SUNON

## Power Motor Fan

## 91.7~120.2 CFM



Model	P/N	Bearing	Rating Voltage (VDC)	Power Current (AMP)	Power Consumption (WATTS)	Speed (RPM)	Air Flow (CFM)	Static Pressure (Inch-H <sub>2</sub> O)	Noise (dBA)	Weight (g)
PMD1209PMB1-A	(2).GN	● VAPO	12	1.04	12.5	4900	120.2	0.71	57.6	190
PMD1209PMB2-A	(2).GN	● VAPO	12	0.71	8.5	4400	106.3	0.56	53.8	190
PMD1209PMB3-A	(2).GN	● VAPO	12	0.47	5.6	3800	91.7	0.43	50.3	190
PMD2409PMB1-A	(2).GN	● VAPO	24	0.51	12.2	4900	120.2	0.71	57.6	190
PMD2409PMB2-A	(2).GN	● VAPO	24	0.40	9.6	4400	106.3	0.56	53.8	190
PMD2409PMB3-A	(2).GN	● VAPO	24	0.25	6.0	3800	91.7	0.43	50.3	190
PMD4809PMB1-A	(2).GN	● VAPO	48	0.24	11.5	4900	120.2	0.71	57.6	190
PMD4809PMB2-A	(2).GN	● VAPO	48	0.16	7.7	4400	106.3	0.56	53.8	190
PMD4809PMB3-A	(2).GN	● VAPO	48	0.12	5.8	3800	91.7	0.43	50.3	190

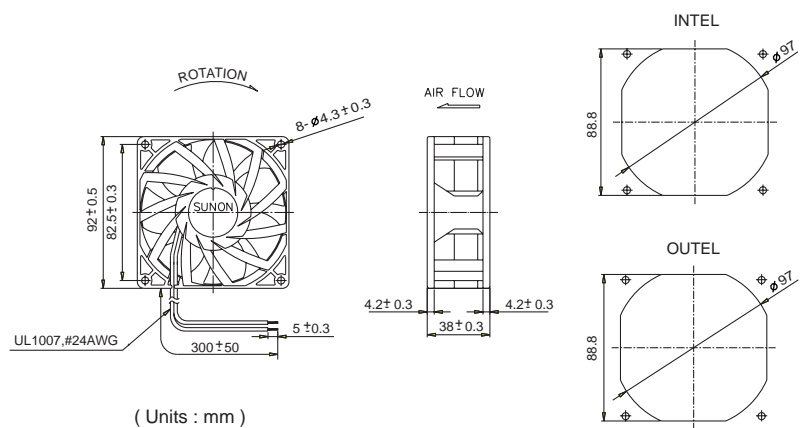
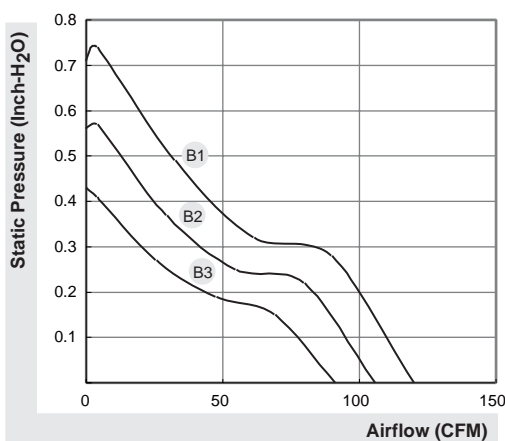

\*All model could be customized on voltage or any other requirements to fit your need.

\*Specifications subject to change without notice. Please Visit SUNON web site at <http://www.sunon.com> for update information.

# 120X120X25 mm

# SUNON

## Power Motor Fan

### 120~150 CFM



Model	P/N	Bearing ● VAPO ⊙ 2BALL	Rating Voltage (VDC)	Power Current (AMP)	Power Consumption (WATTS)	Speed (RPM)	Air Flow (CFM)	Static Pressure (Inch-H <sub>2</sub> O)	Noise (dBA)	Weight (g)
PMD1212PTB1-A	(2).GN	⊙	12	1.0	12.0	4500	150	0.62	54	220
PMD1212PTB2-A	(2).GN	⊙	12	0.72	8.6	4000	133	0.50	51	220
PMD1212PTB3-A	(2).GN	⊙	12	0.54	6.5	3600	120	0.41	48	220
PMD2412PTB1-A	(2).GN	⊙	24	0.49	11.8	4500	150	0.62	54	220
PMD2412PTB2-A	(2).GN	⊙	24	0.36	8.6	4000	133	0.50	51	220
PMD2412PTB3-A	(2).GN	⊙	24	0.28	6.7	3600	120	0.41	48	220
PMD4812PTB1-A	(2).GN	⊙	48	0.26	12.5	4500	150	0.62	54	220
PMD4812PTB2-A	(2).GN	⊙	48	0.19	9.1	4000	133	0.50	51	220
PMD4812PTB3-A	(2).GN	⊙	48	0.14	6.7	3600	120	0.41	48	220

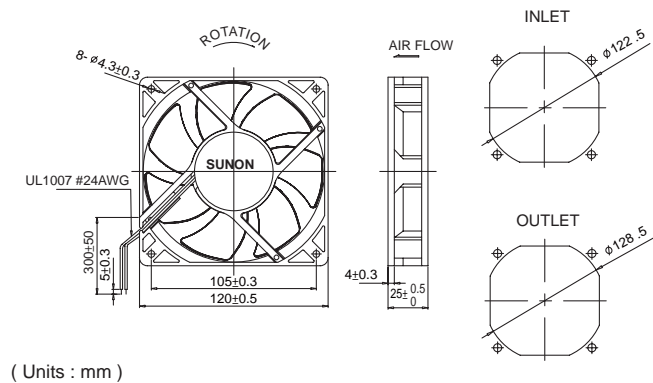
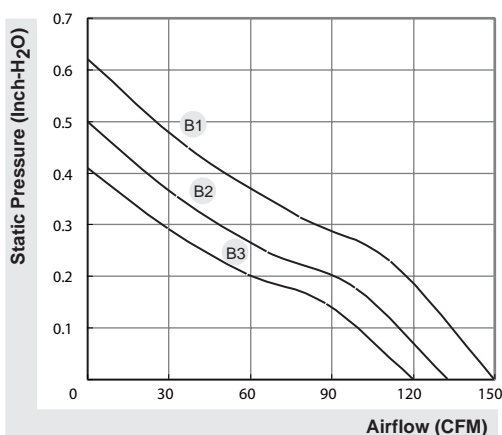

\*All model could be customized on voltage or any other requirements to fit your need.

\*Specifications subject to change without notice. Please Visit SUNON web site at <http://www.sunon.com> for update information.

# 120X120X38 mm

# SUNON

## Power Motor Fan

## 153~190 CFM



Model	P/N	Bearing ● VAPO ⊙ 2BALL	Rating Voltage (VDC)	Power Current (AMP)	Power Consumption (WATTS)	Speed (RPM)	Air Flow (CFM)	Static Pressure (Inch-H <sub>2</sub> O)	Noise (dBA)	Weight (g)
PMD1212PMB1-A	(2).GN	⊙	12	1.6	19.2	4200	190	0.65	54	330
PMD1212PMB2-A	(2).GN	⊙	12	1.2	14.4	3800	170	0.54	51	330
PMD1212PMB3-A	(2).GN	⊙	12	0.83	10.0	3400	153	0.43	48	330
PMD2412PMB1-A	(2).GN	⊙	24	0.76	18.2	4200	190	0.65	54	330
PMD2412PMB2-A	(2).GN	⊙	24	0.57	13.7	3800	170	0.54	51	330
PMD2412PMB3-A	(2).GN	⊙	24	0.42	10.1	3400	153	0.43	48	330
PMD4812PMB1-A	(2).GN	⊙	48	0.4	19.2	4200	190	0.65	54	330
PMD4812PMB2-A	(2).GN	⊙	48	0.3	14.4	3800	170	0.54	51	330
PMD4812PMB3-A	(2).GN	⊙	48	0.22	10.6	3400	153	0.43	48	330

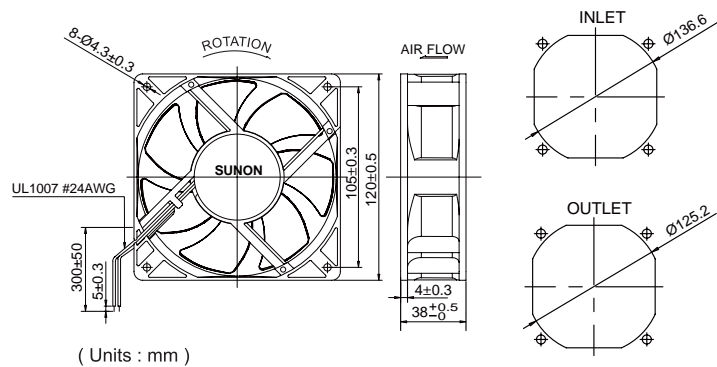
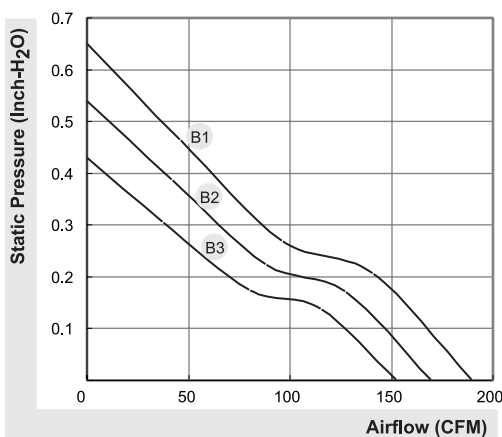

\*All model could be customized on voltage or any other requirements to fit your need.

\*Specifications subject to change without notice. Please Visit SUNON web site at <http://www.sunon.com> for update information.

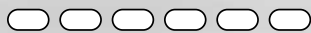

MagLev Green Motor Blower  
Power Motor Blower



# 50X50X15 mm

# SUNON

## MagLev Green Motor Blower

## 2.3~4.7 CFM



Model	P/N	Bearing ● VAPO ⊙ 2BALL	Rating Voltage (VDC)	Power Current (AMP)	Power Consumption (WATTS)	Speed (RPM)	Air Flow (CFM)	Static Pressure (Inch-H <sub>2</sub> O)	Noise (dBA)	Weight (g)
GB1205PHVX-8AY	GN	●	12	0.17	2.0	6000	4.7	0.97	42.2	30
GB1205PHV1-8AY	GN	●	12	0.10	1.2	5000	4.0	0.67	39.8	30
GB1205PHV2-8AY	GN	●	12	0.06	0.7	4000	3.0	0.40	33.4	30
GB1205PHV3-8AY	GN	●	12	0.044	0.5	3000	2.3	0.16	27.0	30

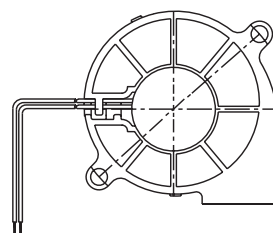
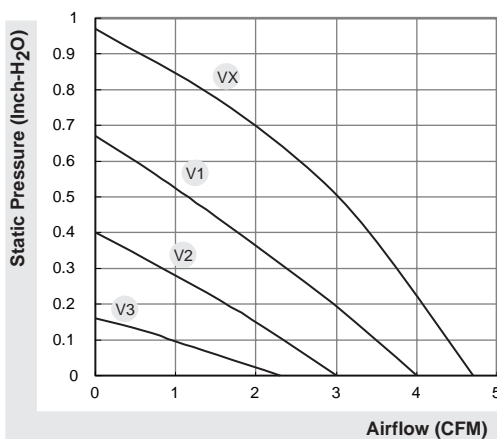

( Units : mm )

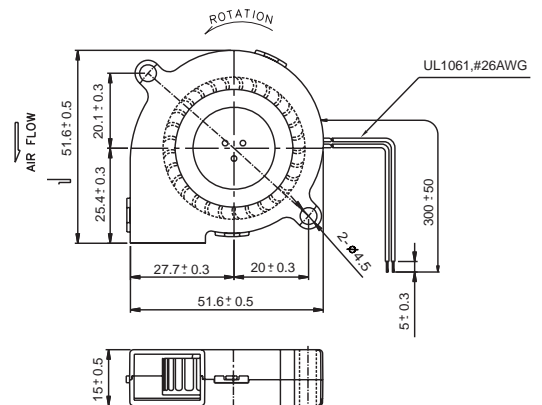

\*All model could be customized on voltage or any other requirements to fit your need.

\*Specifications subject to change without notice. Please Visit SUNON web site at <http://www.sunon.com> for update information.

# 50X50X20 mm

# SUNON

## MagLev Green Motor Blower

### 4.8~5.7 CFM



Model	P/N	Bearing ● VAPO ⊙ 2BALL	Rating Voltage (VDC)	Power Current (AMP)	Power Consumption (WATTS)	Speed (RPM)	Air Flow (CFM)	Static Pressure (Inch-H <sub>2</sub> O)	Noise (dBA)	Weight (g)
GB1205PKV1-8AY	GN	●	12	0.124	1.5	5200	5.7	0.66	35	33
GB1205PKV2-8AY	GN	●	12	0.104	1.3	4800	5.2	0.56	33	33
GB1205PKV3-8AY	GN	●	12	0.088	1.1	4400	4.8	0.46	30	33

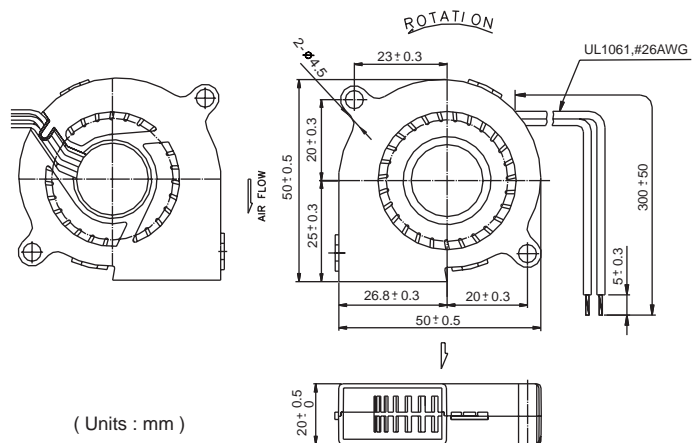
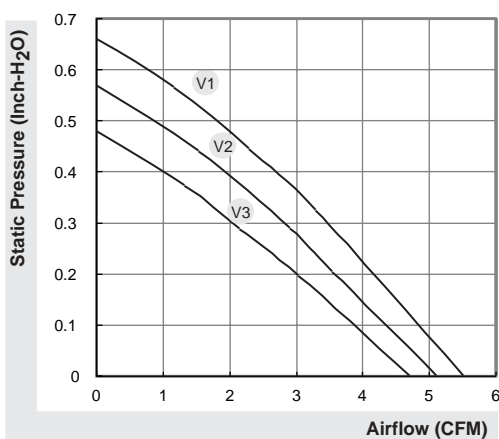

\*All model could be customized on voltage or any other requirements to fit your need.

\*Specifications subject to change without notice. Please Visit SUNON web site at <http://www.sunon.com> for update information.

# 60x60x15 mm

# SUNON

## MagLev Green Motor Blower

### 3.5~5.2 CFM



Model	P/N	Bearing ● VAPO ⊙ 2BALL	Rating Voltage (VDC)	Power Current (AMP)	Power Consumption (WATTS)	Speed (RPM)	Air Flow (CFM)	Static Pressure (Inch-H <sub>2</sub> O)	Noise (dBA)	Weight (g)
GB1206PHV1-AY	GN	●	12	0.105	1.3	4800	5.2	0.44	40.5	45
GB1206PHV2-AY	GN	●	12	0.07	0.8	4200	4.7	0.32	36.0	45
GB1206PHV3-AY	GN	●	12	0.04	0.5	3200	3.5	0.18	29.0	45

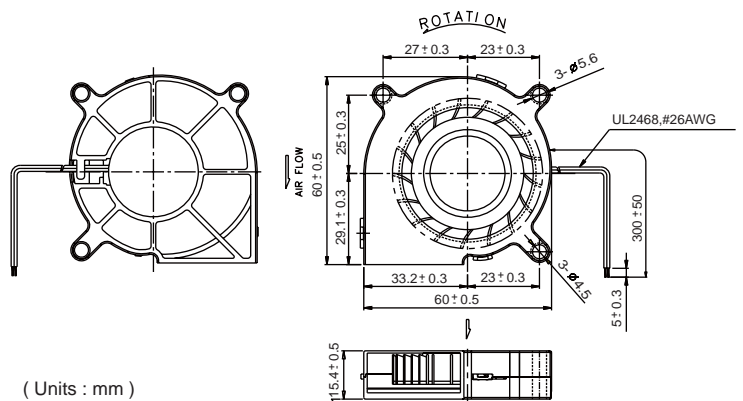
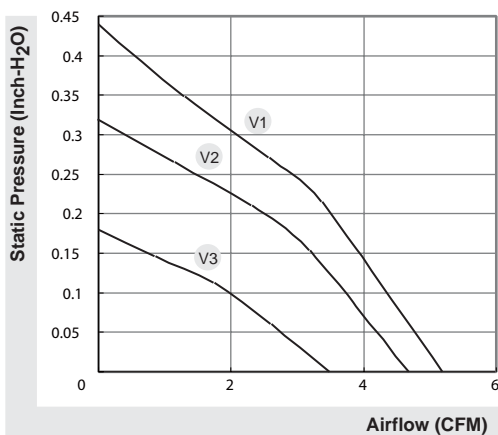

\*All model could be customized on voltage or any other requirements to fit your need.

\*Specifications subject to change without notice. Please Visit SUNON web site at <http://www.sunon.com> for update information.



# 75x75x30 mm

# SUNON

## Power Motor Blower

## 7.5~13.6 CFM



Model	P/N	Bearing ● VAPO ⊕ 2BALL	Rating Voltage (VDC)	Power Current (AMP)	Power Consumption (WATTS)	Speed (RPM)	Air Flow (CFM)	Static Pressure (Inch-H <sub>2</sub> O)	Noise (dBA)	Weight (g)
PMB1275PNB1-AY	(2).GN	⊕	12	0.30	3.6	3400	13.6	0.60	43.5	86.5
PMB1275PNB2-AY	(2).GN	⊕	12	0.23	2.8	3000	12.3	0.48	40.5	86.5
PMB1275PNB3-AY	(2).GN	⊕	12	0.13	1.6	2400	9.6	0.27	33.9	86.5
PMB1275PNB4-AY	(2).GN	⊕	12	0.08	1.0	1900	7.5	0.15	28.0	86.5
PMB2475PNB1-AY	(2).GN	⊕	24	0.17	4.1	3400	13.6	0.60	43.5	86.5
PMB2475PNB2-AY	(2).GN	⊕	24	0.14	3.4	3000	12.3	0.48	40.5	86.5
PMB2475PNB3-AY	(2).GN	⊕	24	0.08	1.9	2400	9.6	0.27	33.9	86.5
PMB2475PNB4-AY	(2).GN	⊕	24	0.05	1.2	1900	7.5	0.15	28.0	86.5

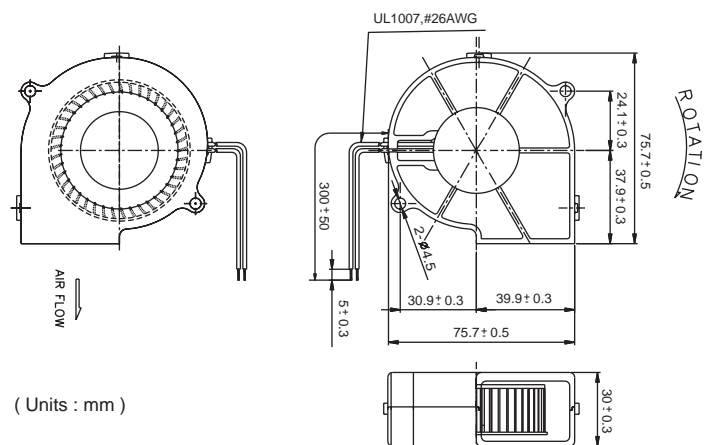
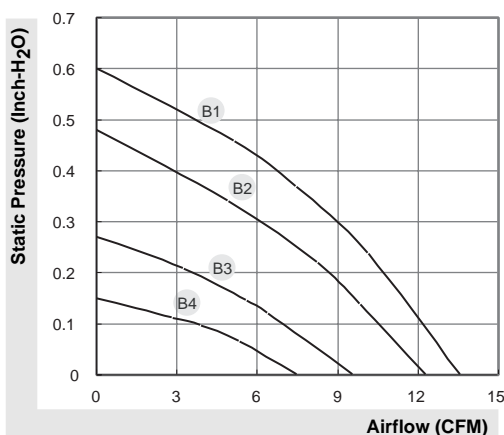

\*All model could be customized on voltage or any other requirements to fit your need.

\*Specifications subject to change without notice. Please Visit SUNON web site at <http://www.sunon.com> for update information.

# 97x94x33 mm

# SUNON

## Power Motor Blower

## 22.4~30.5 CFM



Model	P/N	Bearing ● VAPO ⊕ 2BALL	Rating Voltage (VDC)	Power Current (AMP)	Power Consumption (WATTS)	Speed (RPM)	Air Flow (CFM)	Static Pressure (Inch-H <sub>2</sub> O)	Noise (dBA)	Weight (g)
PMB1297PYB1-AY	(2).GN	⊕	12	0.72	8.6	3600	30.5	0.92	55.8	185
PMB1297PYB2-AY	(2).GN	⊕	12	0.56	6.7	3200	26.6	0.65	53.1	185
PMB1297PYB3-AY	(2).GN	⊕	12	0.30	3.6	2700	22.4	0.43	50.0	185
PMB2497PYB1-AY	(2).GN	⊕	24	0.39	9.4	3600	30.5	0.92	55.8	185
PMB2497PYB2-AY	(2).GN	⊕	24	0.25	6.0	3200	26.6	0.65	53.1	185
PMB2497PYB3-AY	(2).GN	⊕	24	0.16	3.8	2700	22.4	0.43	50.0	185
PMB4897PYB1-AY	(2).GN	⊕	48	0.17	8.2	3600	30.5	0.92	55.8	185
PMB4897PYB2-AY	(2).GN	⊕	48	0.13	6.2	3200	26.6	0.65	53.1	185
PMB4897PYB3-AY	(2).GN	⊕	48	0.09	4.3	2700	22.4	0.43	50.0	185

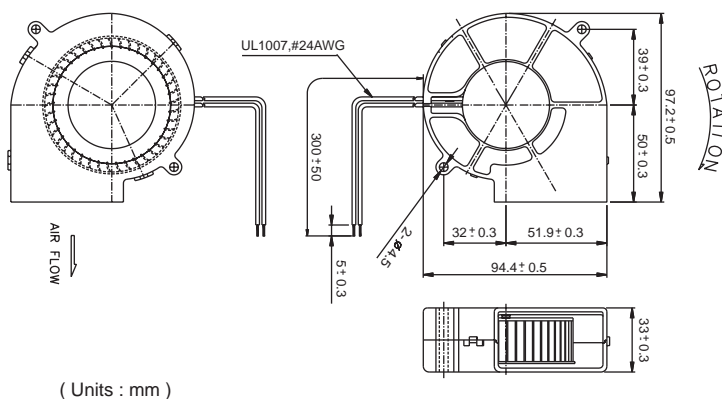
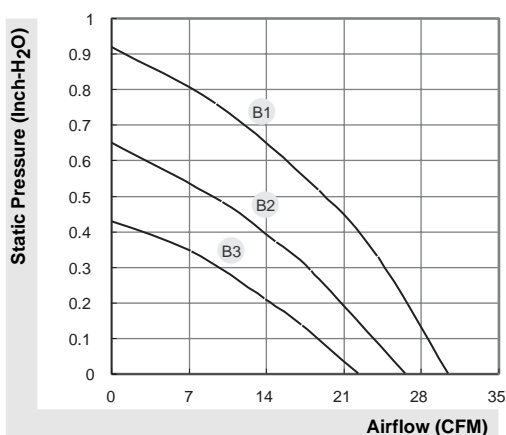

\*All model could be customized on voltage or any other requirements to fit your need.

\*Specifications subject to change without notice. Please Visit SUNON web site at <http://www.sunon.com> for update information.

# 120x120x32 mm

# SUNON

## Power Motor Blower

## 31.4~35.9 CFM



Model	P/N	Bearing ● VAPO ⊙ 2BALL	Rating Voltage (VDC)	Power Current (AMP)	Power Consumption (WATTS)	Speed (RPM)	Air Flow (CFM)	Static Pressure (Inch-H <sub>2</sub> O)	Noise (dBA)	Weight (g)
PMB1212PLB2-A	(2).GN	⊙	12	0.82	9.8	2500	35.9	0.89	53.8	250
PMB1212PLB3-A	(2).GN	⊙	12	0.45	5.4	2100	31.4	0.64	49.6	250
PMB2412PLB2-A	(2).GN	⊙	24	0.38	9.1	2500	35.9	0.89	53.8	250
PMB2412PLB3-A	(2).GN	⊙	24	0.24	5.8	2100	31.4	0.64	49.6	250
PMB4812PLB3-A	(2).GN	⊙	48	0.12	5.8	2100	31.4	0.64	49.6	250

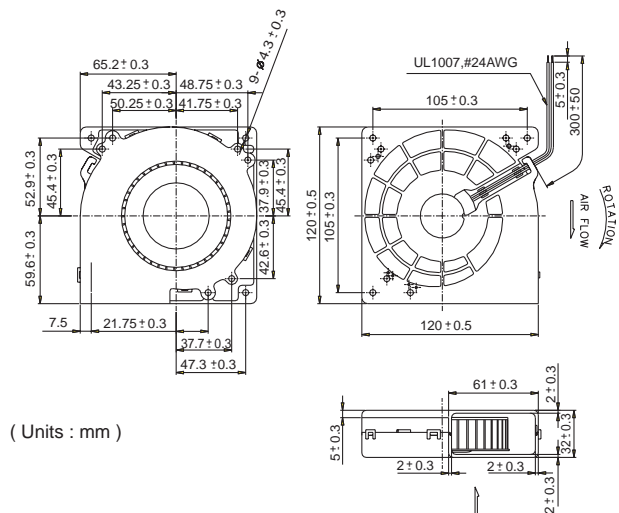
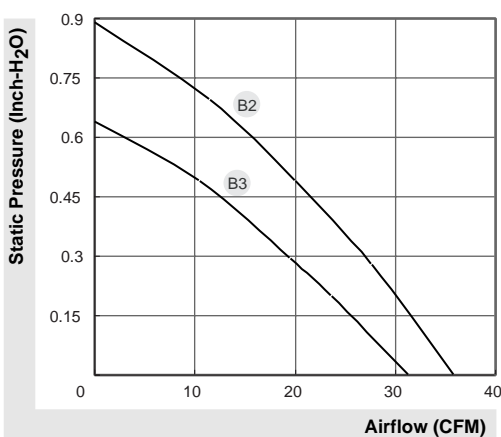

\*All model could be customized on voltage or any other requirements to fit your need.

\*Specifications subject to change without notice. Please Visit SUNON web site at <http://www.sunon.com> for update information.



MagLev AC Fan



## MagLev Frequency-Switching Motor (MagLev AC Fan)

 Low Power Consumption  Super High Airflow  Smart Multi-functional Controls

Sunon MagLev AC Fans with MagLev Frequency-Switching Motors, not only contain the three features of low noise, high temperature endurance, and super long life inherited from the MagLev motor design, but also are superior in low power consumption, super high airflow, and smart multi-functional controls. By adopting the design principle of frequency-switching circuit controls, Sunon MagLev AC Fans are the best solution for AC-powered cooling.

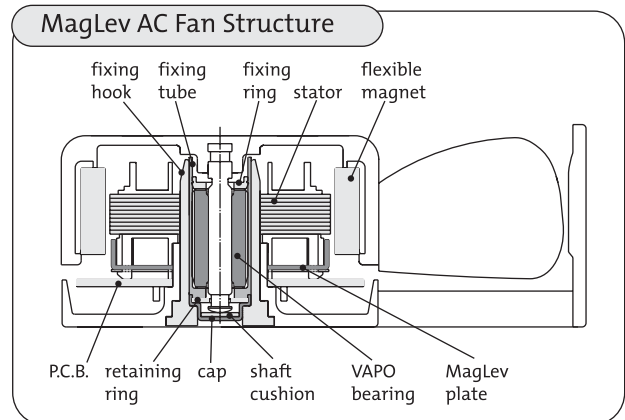

### MagLev AC Fans compared with conventional AC fans

#### MagLev AC Fan

1. Due to the patented design, Sunon MagLev AC Fan's hub area is significantly reduced, yielding a larger impeller which can offer double the airflow of conventional AC fans.
2. Rotational speed can be adjusted per customer's requirement.
3. Frequency-switching circuit design can reduce the power consumption to less than half that of conventional AC fans. With an input voltage of 115V/50Hz, the 80mm AC fans offer power consumptions of only 3.6W.
4. Provides output signal for rotational speed detection.
5. The MagLev design, with its compact size features low noise.
6. By rotating with full exertion in a fixed operational orbit, the MagLev AC fan eliminates vibration and prolongs lifespan.
7. MagLev AC Fans with its novel technology goes beyond the norm and provides unlimited possibilities for customers' future demands.

#### Conventional AC fan

1. Limited by the motor-wire wrapping process, the resulting motor hube is larger than MagLev AC fans.
2. Limited rotational speed, can't adjust to customers demand for the highest rotational speed.
3. When directly connected to AC power supplies, the power consumption is higher.
4. It's difficult for conventional motor design to provide output signal for torational speed detection.
5. Conventional AC fans have encountered a bottleneck in their technical development, and therefore it is difficult to make any further break through.

# 60x60x25 mm

# SUNON

## MagLev Motor AC Fan

## 17.5 / 18 CFM



Model	P/N	Bearing ● VAPO ⊙ 2BALL	Rating Voltage (VAC)	Freq. (Hz)	Power Current (AMP)	Power Consumption (WATTS)	Speed (RPM)	Air Flow (CFM)	Static Pressure (Inch-H <sub>2</sub> O)	Noise (dBA)	Weight (g)
MA1062-HVL	GN	●	115	50/60	0.18/0.17	3.2/3.3	4100/4200	17.5/18	0.19/0.20	30/31	81
MA2062-HVL	GN	●	230	50/60	0.20/0.21	3.7/3.8	4100/4200	17.5/18	0.19/0.20	30/31	81

Frame : PBT Plastic

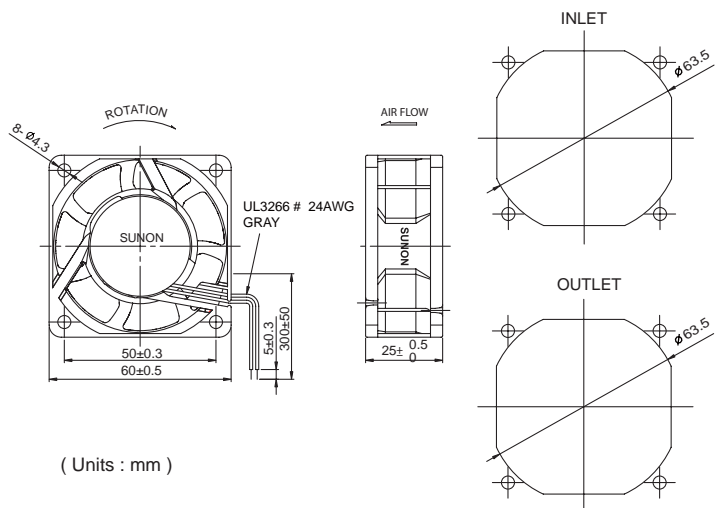
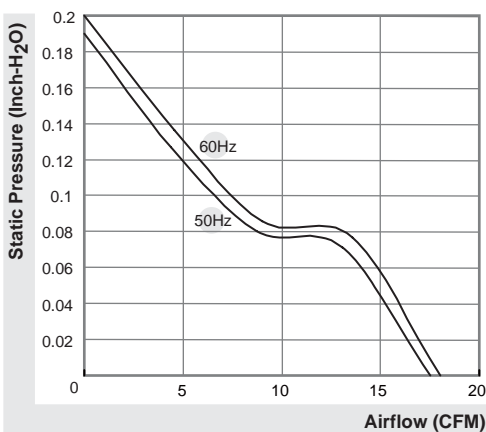

\*The rated current is TRUE RMS current measured by BASE-450 (Autoranging Digital V-A-W METER).

\*All model could be customized on voltage or any other requirements to fit your need.

\*Specifications subject to change without notice. Please Visit SUNON web site at <http://www.sunon.com> for update information.

# 70X70X25 mm

# SUNON

## MagLev Motor AC Fan

## 28 / 29 CFM



Model	P/N	Bearing ● VAPO ⊙ 2BALL	Rating Voltage (VAC)	Freq. (Hz)	Power Current (AMP)	Power Consumption (WATTS)	Speed (RPM)	Air Flow (CFM)	Static Pressure (Inch-H <sub>2</sub> O)	Noise (dBA)	Weight (g)
MA1072-HVL	GN	●	115	50/60	0.18/0.18	2.8/3.0	3800/3900	28/29	0.17/0.18	30/31	90
MA2072-HVL	GN	●	230	50/60	0.23/0.229	3.6/3.4	3800/3900	28/29	0.17/0.18	30/31	90

Frame : PBT Plastic

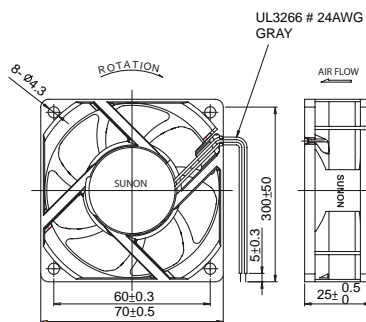
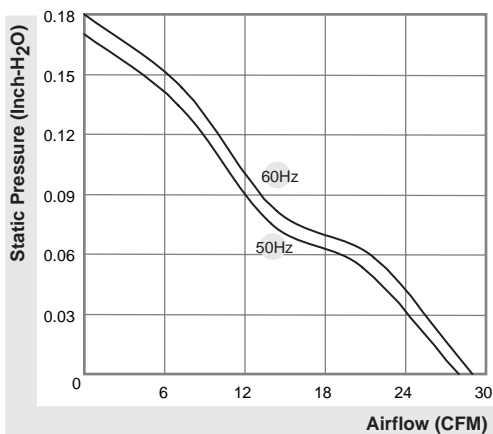

( Units : mm )

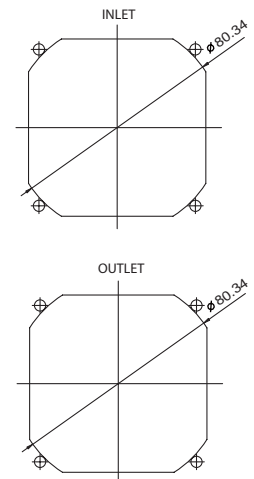

\*The rated current is TRUE RMS current measured by BASE-450 (Autoranging Digital V-A-W METER).

\*All model could be customized on voltage or any other requirements to fit your need.

\*Specifications subject to change without notice. Please Visit SUNON web site at <http://www.sunon.com> for update information.

# 80x80x25 mm

# SUNON

## MagLev Motor AC Fan

## 40 / 41 CFM



Model	P/N	Bearing ● VAPO ⊙ 2BALL	Rating Voltage (VAC)	Freq. (Hz)	Power Current (AMP)	Power Consumption (WATTS)	Speed (RPM)	Air Flow (CFM)	Static Pressure (Inch-H <sub>2</sub> O)	Noise (dBA)	Weight (g)
MA1082-HVL	GN	●	115	50/60	0.112/0.116	3.6/3.6	3200/3300	40/41	0.14/0.15	32/33	102.2
MA2082-HVL	GN	●	230	50/60	0.102/0.101	4.6/4.6	3200/3300	40/41	0.14/0.15	32/33	102.2

Frame : PBT Plastic

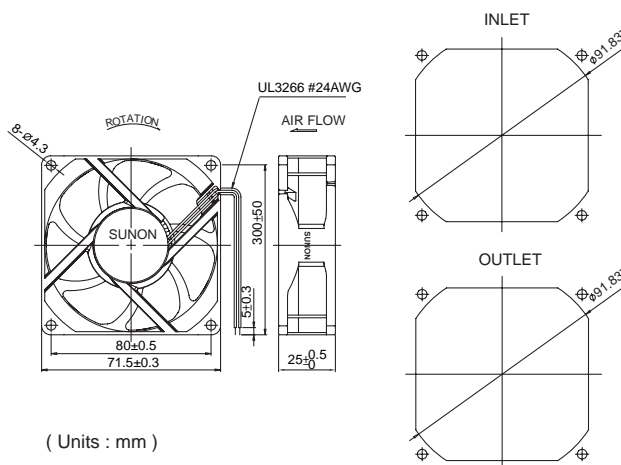
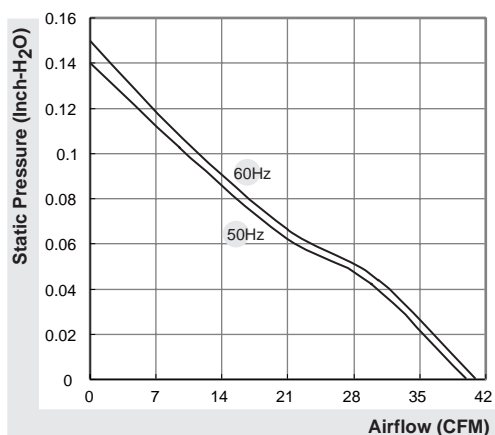

\*The rated current is TRUE RMS current measured by BASE-450 (Autoranging Digital V-A-W METER).

\*All model could be customized on voltage or any other requirements to fit your need.

\*Specifications subject to change without notice. Please Visit SUNON web site at <http://www.sunon.com> for update information.



# 92X92X25 mm

# SUNON

## MagLev Motor AC Fan

## 52 / 54 CFM



Model	P/N	Bearing ● VAPO ⊙ 2BALL	Rating Voltage (VAC)	Freq. (Hz)	Power Current (AMP)	Power Consumption (WATTS)	Speed (RPM)	Air Flow (CFM)	Static Pressure (Inch-H <sub>2</sub> O)	Noise (dBA)	Weight (g)
MA1092-HVL	GN	●	115	50/60	0.114/0.118	3.6/3.6	2900/3000	52/54	0.12/0.14	31/32	119.7
MA2092-HVL	GN	●	230	50/60	0.103/0.106	4.6/4.6	2900/3000	52/54	0.12/0.14	31/32	119.7

Frame : PBT Plastic

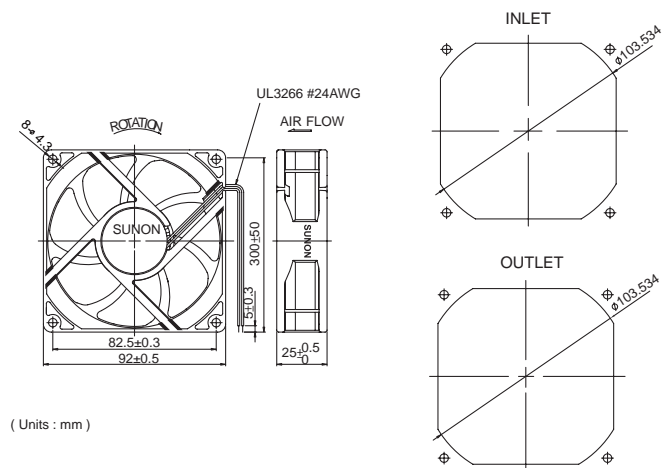
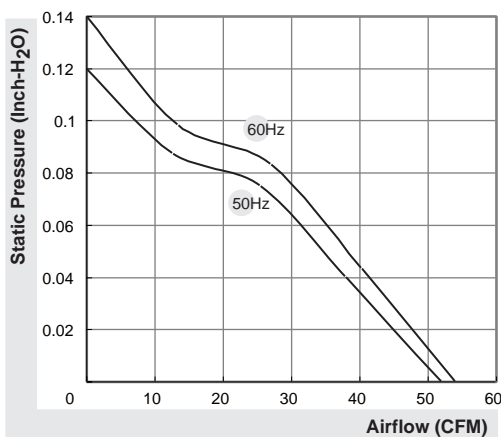

\*The rated current is TRUE RMS current measured by BASE-450 (Autoranging Digital V-A-W METER).

\*All model could be customized on voltage or any other requirements to fit your need.

\*Specifications subject to change without notice. Please Visit SUNON web site at <http://www.sunon.com> for update information.

Headquarters:

**Sunonwealth Electric Machine Industry Co., Ltd.**

No.30, Lane 296, Sinya Rd., Cianjhen District, Kaohsiung, Taiwan

TEL : +886-7-8135888

FAX :+886-7-8230505/8230606/8231010

URL: <http://www.sunon.com>

E-mail: [sunon@email.sunon.com.tw](mailto:sunon@email.sunon.com.tw)

**Sunon Inc. (U.S.A.)**

1075 West Lambert Road Suite A, Brea, California 92821, U.S.A

TEL : +1-714-255-0208

FAX :+ 1-714-255-0802

URL : <http://www.sunonusa.com>

E-mail : [info@sunon.com](mailto:info@sunon.com)

**Sunon SAS (Europe)**

Parc Medicis, 66, Ave Des Pepinieres 94832, Fresnes Cedex-France

TEL : +33-1-46154515

FAX : +33-1-46154510

URL: <http://www.sunoneurope.com>

E-mail : [info@sunoneurope.com](mailto:info@sunoneurope.com)

**Sunon Corporation (Japan)**

Stork Minami Otsuka 4Fl.33-1, 2 Chome,  
Minami Otsuka Toshimaku, Tokyo, Japan 170-0005

TEL : +81-3-5395-3069

FAX: +81-3-5395-3080

URL: <http://www.sunon.co.jp>

E-mail : [info@sunon.co.jp](mailto:info@sunon.co.jp)

**Sunon Technologies Pte Ltd. (Singapore)**

10 Toh Guan Road, #03-08 TT International Tradepark, Singapore 608838

TEL : +65-6795-0300

FAX :+65-6795-0600

E-mail : [info@sunon.com.sg](mailto:info@sunon.com.sg)

**Sunonwealth Electric Machine Industry (HK) Ltd. (Hong Kong)**

1906 Nan Fung Center, 264 Castle Peak Road, Tsuen Wan, Hong Kong

TEL : + 852-24-111-388

FAX : + 852-24-050-707

E-mail : [info@sunon.com.hk](mailto:info@sunon.com.hk)

**Sunon Shanghai Office (Shanghai, China)**

TEL : +86-021-54072207

FAX :+86-021-54072207 Ext:23

URL: <http://www.sunon.com.cn>

**Sunon Shen Zhen Office (Shen Zhen, China)**

TEL : +86-755-26880688

FAX :+86-755-26880288

E-mail : [info@sunon.com.cn](mailto:info@sunon.com.cn)

**Sunon Guangzhou Office (Guangzhou, China)**

TEL : +86-20-87788928

FAX :+86-20-87786786

## X-ON Electronics

Largest Supplier of Electrical and Electronic Components

*Click to view similar products for [sunon](#) manufacturer:*

Other Similar products are found below :

[MB50151V2-000U-A99](#) [UF3A3-700](#) [UB3H3-500](#) [PMB2475PNB3-AY.\(2\).GN](#) [KD1208PHB1.13.\(2\).GN](#) [B2-10](#) [SM203-13002](#) [PE80254V1-000U-A99](#) [B2-20](#) [C2-10](#) [C2-20](#) [PF92251V1-1000U-A99](#) [ME80201V2-000U-A99](#) [PE92252B1-000C-AB9](#) [MC30101V2-000C-A99\(165mm\)](#) [MF20100V4-1Q04C-G99](#) [PE92254B2-000C-F99](#) [MC30150V1-000C-A99](#) [PE80252B1-000C-AB9](#) [MF20060V3-1Q07A-G99](#) [MC25100V2-000C-G99](#) [PMD2412PMB1-A\(2\).R.GN.I55](#) [EE60251B2-000U-999](#) [AB1123-HST.GN](#) [D09023250G-00](#) [MF25100V1-1000U-A99](#) [PF80251V1-1000U-F99](#) [EE92251B3-000U-A99](#) [PF92381B1-000U-A99](#) [VF40281BX-000U-A9H](#) [LA004-024A83DY](#) [SM203-14001Y](#) [SM203-13004Y](#) [SM205-13001](#) [F92-B](#) [FG-8/45](#) [PMD1212PTB1-A.\(2\).GN](#) [LA004-011A99DN](#) [SF11592A-1092HSL.GN](#) [CF4113HBL-000U-ABD](#) [MF20100V1-1000U-A99](#) [DP203A-2123LBL.\(5\).GN](#) [PF40281B3-000U-A99](#) [HA60150V3-E03U-A99](#) [MF30060V1-1000U-G99](#) [MC20100V3-Q00C-G99](#) [MEC0382V1-000U-A99](#) [PB-08](#) [SM203-14002Y](#) [EEC0252B3-000U-A99](#)