

SK3410R200

Band41, RF-Rx SAW Filter
Revision 0 : April 2020

MSL 3 Device



- Description**
- Features**
- Package & Dimensions**
- Pin configuration**
- Matching Circuit(recommended)**
- Absolute Maximum Ratings**
- Electrical Specifications**
- Packing material**
- Marking**
- Recommended Soldering Profile**
- Important Notice**

1 Description

SK3410R200 is a high-performance Surface Acoustic Wave (SAW) bandpass filter optimized for TD-LTE applications operating in the range of 2.496-2.690 GHz. It is designed to provide both low insertion loss in the Band 41 and high rejection in the adjacent cellular Bands for mobile devices.

SK3410R200 uses advanced Chip Scale Package (CSP) technology and is housed in an industry-standard, 5-pin 1.1mm x 0.9mm package with a low profile of 0.6mm max.

2 Features

- Low Insertion Loss: 1.4dB at Mid-Band
- High Rejection in WIFI
- Small Footprint: $0.25 \pm 0.03\text{mm} \times 0.20 \pm 0.03\text{mm}$.
- Package size $1.1 \pm 0.05\text{mm} \times 0.9 \pm 0.05\text{mm}$
- Electrostatic Sensitive Device(ESD)
- Package height 0.6mm max.
- Single-Ended Operation
- RoHS Compliant

3 Package & Dimensions

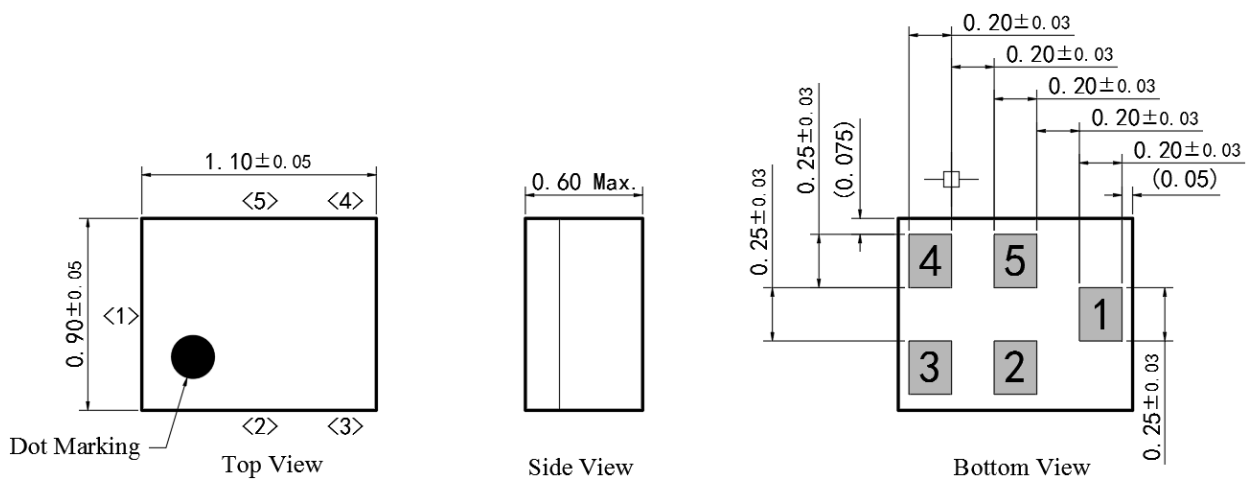

Figure 1: Drawing of Package with each tolerance range

4 Pin configuration

- 1 Input (recommended)
- 4 Output (recommended)
- 2,3,5 To be grounded

5 Matching Circuit(recommended)

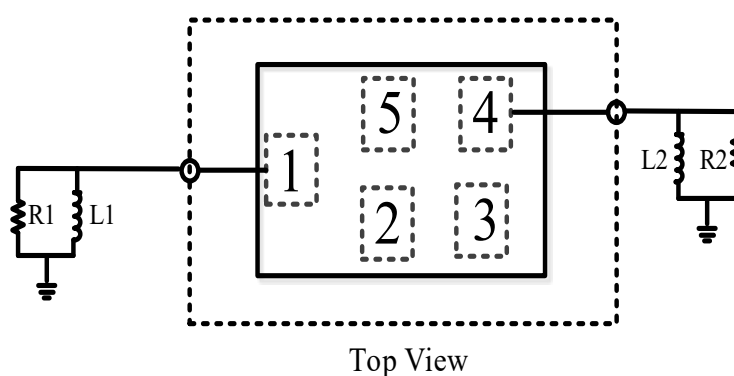

Figure 2: Schematic of matching circuit.

R1: 50 Ohm	L1: 2.2 nH (Q \approx 50 @2.600GHz)
R2: 50 Ohm	L2: 2.4 nH (Q \approx 50 @2.600GHz)

6 Absolute Maximum Ratings

Parameter	Rating	Unit
Operating Temperature	-25 to +85	°C
Storage Temperature	-40 to +85	°C
Maximum Input Power	+15	dBm
Maximum DC Voltage	5	V
Input terminating impedance	50	Ω
Output terminating impedance	50	Ω
Input Power@input port	Pin=15dBm Continuous wave for 5000h@55° C	

7 Electrical Specifications

Parameter	Conditions	Min	Typ.	Max	Unit
Insertion Loss	2496 - 2520 MHz	-	2.6	3.3	dB
	2520 - 2690 MHz	-	2.5	3.0	dB
Passband Ripple	2496 - 2520 MHz	-	1.2	2.4	dB
	2520 - 2690 MHz	-	1.0	2.0	dB
Attenuation	DC - 916 MHz	40	45	-	dB
	925 - 960 MHz	36	42	-	dB
	1226.57 - 1228.63 MHz	30	34	-	dB
	1242.42 - 1249.14 MHz	29	33	-	dB
	1248 - 1564 MHz	22	28	-	dB
	1559 - 1605.89 MHz	20	23	-	dB
	1615 - 2400 MHz	10	19	-	dB
	1710 - 1785 MHz	15	18	-	dB
	1805 - 1850 MHz	14	16	-	dB
	1880 - 1920 MHz	13	15	-	dB
	1920 - 1980 MHz	12	14	-	dB
	2110 - 2170 MHz	10	12	-	dB
	2401 - 2468 MHz	26	32	-	dB
	2451 - 2473 MHz	15	20	-	dB
	2456 - 2478 MHz	8	16	-	dB
	2461 - 2483 MHz	5	10	-	dB
2775 - 5000 MHz	15	20	-	dB	
VSWR(input)	2496 - 2690 MHz	-	1.7	2.0	-
VSWR(output)	2496 - 2690 MHz	-	1.7	2.0	-

Transmission coefficient



Figure 3: |S21|



Figure 4: Wide Band |S21|

Reflection coefficients

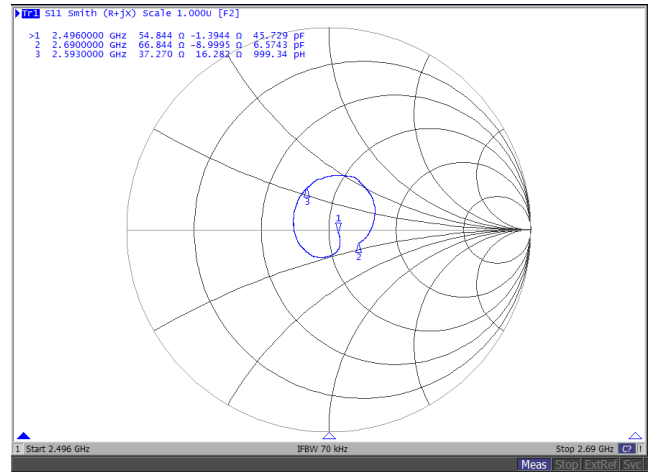
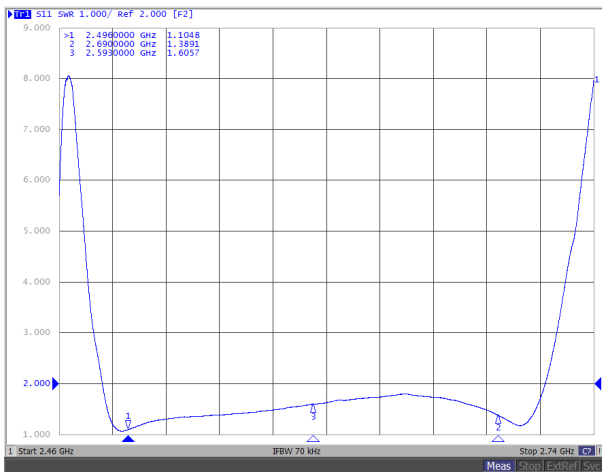

Figure 5: Reflection coefficient for S11

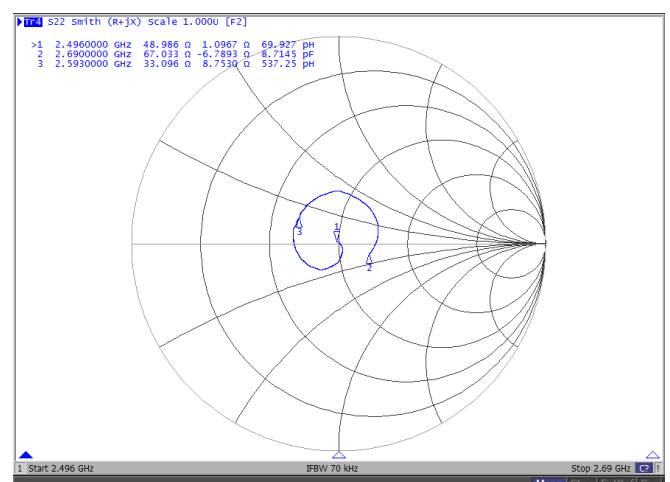
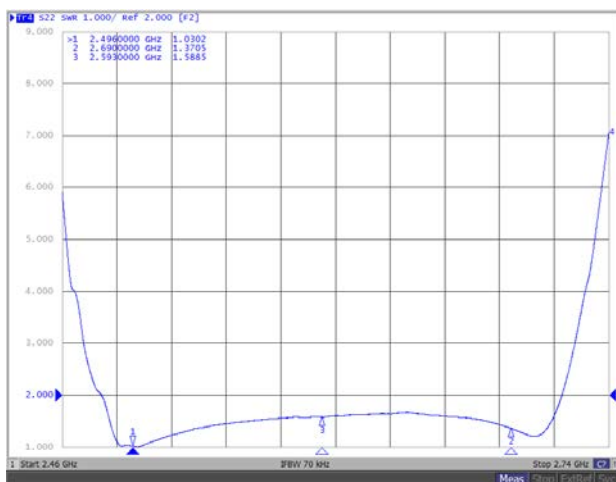

Figure 6: Reflection coefficient for S22

8 Packing material

8.1 Tape

Tensile Strength of Carrier Tape: Carrier tape 10N or more; Cover tape 5N or more. Packaging quantities: 5000 PCS / Reel.

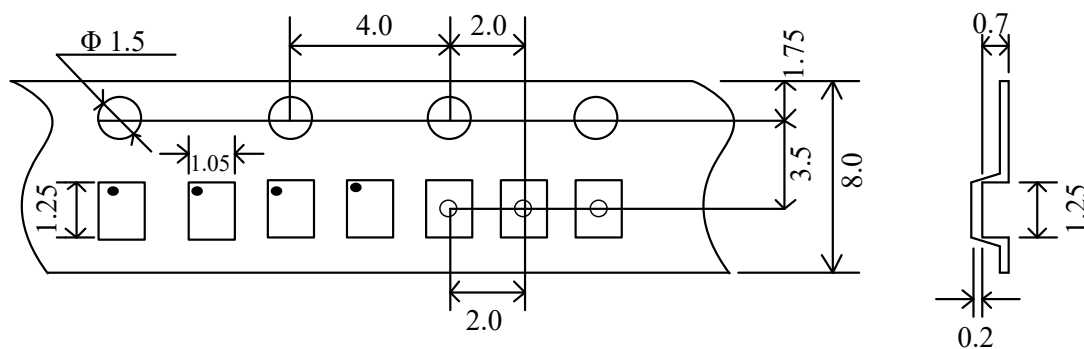

Figure 7: Drawing of tape with tape dimensions according above.

8.2 Reel with diameter of 178mm

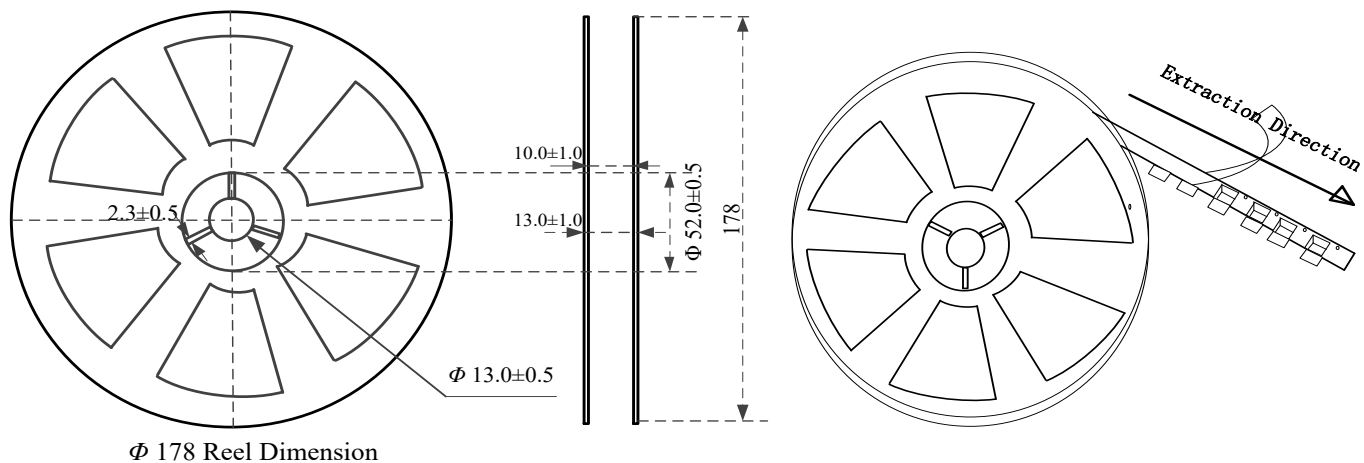

Figure 8: Drawing of reel with diameter of 178mm.

9 Marking

Products are marked with product date number and lot number encoded according to below:

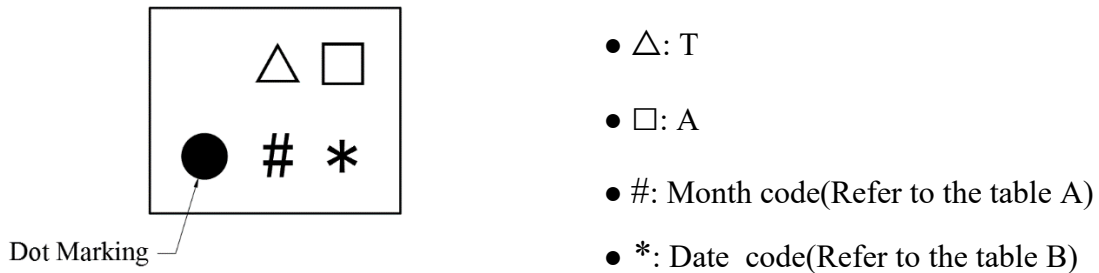

Figure 11: Drawing of Mark information for Product

10 Recommended Soldering Profile

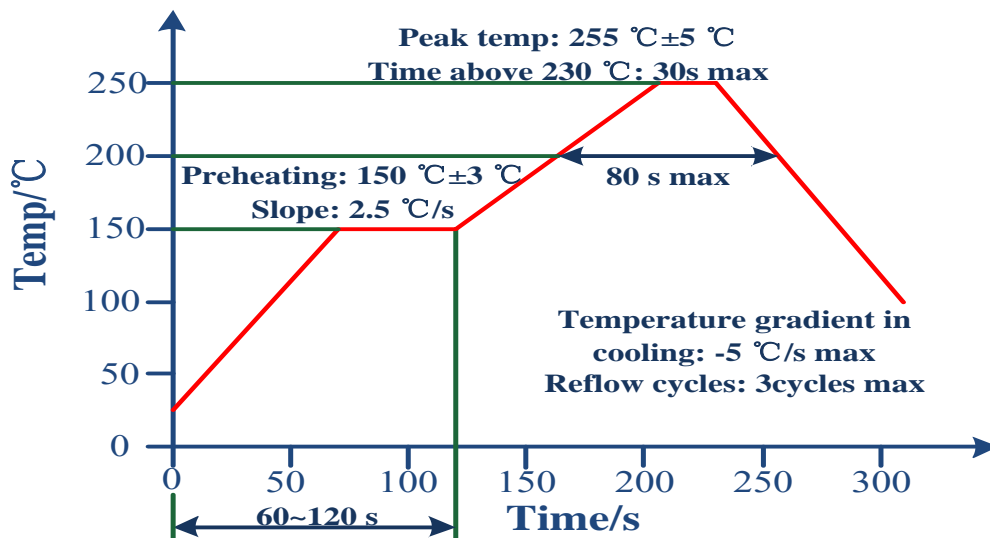

Figure 12: Recommended Reflow profile for convection and infrared soldering-lead-free solder.

11 Important Notice

- SAW devices should not be used in any type of fluid such as water, oil, organic solvent, etc..
- Do not operate outside the recommended operating temperature range.
- Sudden change of temperature shall be avoided, deterioration of the characteristics may occur.
- Be careful of temperature and duration when soldering.
- Do not place soldering iron on the body.
- Be careful not to subject for excessive force.
- SAW devices are electrostatic sensitive. Please avoid static voltage during operation and storage.
- Ultrasonic cleaning shall be avoided. Ultrasonic vibration may cause destruction.
- ROHS compliance.
- ESD (Electrostatic Discharge) sensitive device.

X-ON Electronics

Largest Supplier of Electrical and Electronic Components

Click to view similar products for [Signal Conditioning](#) category:

Click to view products by [Suntek](#) manufacturer:

Other Similar products are found below :

[MAPDCC0004](#) [PD0409J5050S2HF](#) [HHS-109-PIN](#) [AFS14A35-1591.50-T3](#) [DSS-313-PIN](#) [JP510S](#) [LFB212G45SG8C341](#)
[LFB322G45SN1A504](#) [LFL182G45TC3B746](#) [SF2159E](#) [FM-104-PIN](#) [CER0813B](#) [MAPDCC0005](#) [3A325](#) [BD0810N50100AHF](#) [JHS-115-PIN](#)
[DC0710J5005AHF](#) [DC2327J5005AHF](#) [43020](#) [LFB2H2G60BB1C106](#) [LFL15869MTC1B787](#) [X3C19F1-20S](#) [XC3500P-20S](#) [SF2194E](#)
[CDBLB455KCAX39-B0](#) [RF1353C](#) [051157-0000](#) [1E1305-3](#) [1F1304-3S](#) [1G1304-30](#) [B0922J7575AHF](#) [TP-103-PIN](#) [BD1222J50200AHF](#)
[BD1722J50100AHF](#) [2450DP39K5400E](#) [BD0810J50150AHF](#) [BD1722J50200AHF](#) [DSS-113-PIN](#) [DS-327-PIN](#) [DS-313-PIN](#) [TP-101-PIN](#)
[856019](#) [JP506S](#) [XC0900P-10S](#) [XC0900B-30S](#) [CHS-134-PIN](#) [CHE1260-QAG](#) [11305-10](#) [3A412S](#) [X3C06A4-03S](#)