

# SK3530H

SAW Dual Filter, 1in2out /1511  
For GPS\_GLONASS\_GALILEO

**MSL 3 Device**



- Description
- Applications
- Features
- Pin Configuration/Application Diagram (Top view)
- Electrical Characteristics
- Typical Performance
- Package Outline Dimensions
- Tape and Reel Dimensions
- Reflow Chart

## Description

- SK3530H is the low-loss RF SAW filter for GPS L1+L5 band.
- High stability and reliability with good performance and no adjustment.
- Ni, gold-plated terminals.
- RoHS compatible

## Features

- Single-ended input and dual-ended output operation
- Low Insertion Loss
- Moisture Sensitivity: MSL3
- RoHS compliant
- Electrostatic Sensitive Device (ESD)
- CSP (10-pin, 1.5mm x 1.1mm x 0.7mm) package

## Applications

- GPS dual SAW RX filter for L1+L5
- Low-loss, pre-LNA comb filter for GNSS

## Pin Configuration/Application Diagram (Top view)

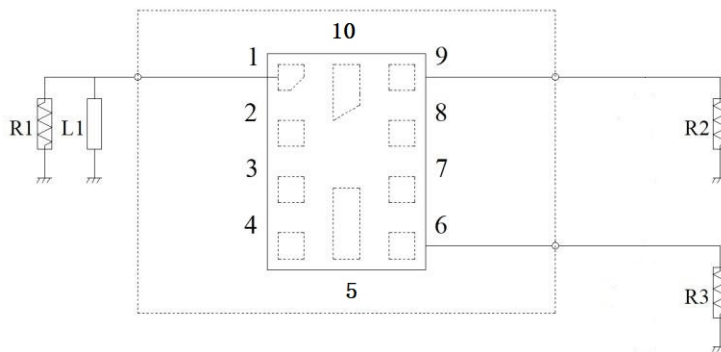

Figure 1 Pin Configuration and Application Diagram

Table 1 Pin Descriptions

Pin	Pin Name	Pin Description	Pin	Pin Name	Pin Description
1	Input	SAW input	6	Output	Output GPS L1
2	GND	Analog VSS	7	GND	Analog VSS
3	GND	Analog VSS	8	GND	Analog VSS
4	GND	Analog VSS	9	Output	Output GPS L5
5	GND	Analog VSS	10	GND	Analog VSS

Table 2 Recommended component value

Component	Value	Units	Component	Value	Units
R1	50.0	Ohm	L1	4.3	nH
R2	50.0	Ohm			
R3	50.0	Ohm			

## Electrical Characteristics

Table 3 Absolute Maximum Ratings

Parameter	Unit	Minimum	Typical	Maximum
<b>GPS L5 Spec requirement Spec requirement</b>				
Frequency Range	MHz	1166.22	1176.5	1186.68
Max insertion loss (full temp)	dB	/	1.7	1.9
Max insertion loss (-10~85°C)	dB	/	/	/
Amplitude Ripple (full temp)	dB	/	1.0	2.0
Amplitude Ripple (25°C)	dB	/	1.3	1.8
VSWR (input port-ant) (full temp)	/	/	1.3	2.0
VSWR (output port-tx/rx) (full temp)	/	/	1.3	2.0
VSWR (input port-ant) (25°C)	/	/	1.3	1.8
VSWR (output port-tx/rx) (25°C)	/	/	1.3	1.8
Input port impedance	Ohm	/	50	/
Output port impedance	Ohm	/	50	/
EVM	/	/	/	/
Group delay	ns	/	15	/
Amplitude balance(for balance Type)	dB	/	/	/
Phase balance(for balance Type)	°	/	/	/
Absolute attenuation(dB)	10-824MHz	35	50	/
	824-915 MHz	35	50	/
	825-960 MHz	35	45	/
	1427-1463 MHz	32	40	/
	1710-1785MHz	32	41	/
	1850-2025MHz	30	38	/
	2300-2690 MHz	30	35	/
	3400-3800 MHz	25	35	/
	4400-4900 MHz	24	33	/
	5150-5925 MHz	15	24	/
2nd harmonics	dBm	/	/	-40
3rd harmonics	dBm	/	/	-40
Other higher-order harmonics(<=12.75G)	dBm	/	/	-40
2nd harmonics	dBm	/	/	-36
3rd harmonics	dBm	/	/	-36
Other higher-order harmonics(<=12.75G)	dBm	/	/	-36

**Table 4 Specifications GPS + COMPASS + GLONASS**

Parameter	Unit	Minimum	Typical	Maximum
<b>GPS L1+Beidou+Glonass Spec requirement</b>				
Center Frequency	MHz		1582.5	
Frequency Range (GPS L1 )	MHz	1574.39		1576.45
Max insertion loss (full temp)	dB	/	1.6	2.2
Amplitude Ripple (full temp)	dB	/	0.6	2.0
Amplitude Ripple (25°C)	dB	/	0.6	1.8
VSWR (input port-ant) (full temp)	/	/	1.6	2.0
VSWR (output port-tx/rx) (full temp)	/	/	1.6	2.0
VSWR (input port-ant) (25°C)	/	/	1.5	1.8
VSWR (output port-tx/rx) (25°C)	/	/	1.5	1.8
Group delay ripple	ns	/	3.0	
Frequency Range (BeiDou)	MHz	1559.05		1563.15
Max insertion loss (full temp)	dB	/	1.9	2.2
Max insertion loss (25°C)	dB	/	1.7	2
Amplitude Ripple(full temp)	dB	/	1.0	2.0
Amplitude Ripple (25°C)	dB	/	1.0	1.8
VSWR (input port-ant) (full temp)	/	/	1.6	2.0
VSWR (output port-tx/rx) (full temp)	/	/	1.6	2.0
VSWR (input port-ant) (25°C)	/	/	1.5	1.8
VSWR (output port-tx/rx) (25°C)	/	/	1.5	1.8
Group delay ripple	ns	/	3.0	/
Frequency Range (Glonass)	MHz	1597.55		1605.89
Max insertion loss (full temp)	dB	/	1.9	2.2
Max insertion loss (25°C)	dB	/	1.7	2
Amplitude Ripple (full temp)	dB	/	0.8	2.0
Amplitude Ripple (25°C)	dB	/	0.7	1.8
VSWR (input port-ant) (full temp)	/	/	1.6	2.0
VSWR (output port-tx/rx) (full temp)	/	/	1.6	2.0
VSWR (input port-ant) (25°C)	/	/	1.3	1.8
VSWR (output port-tx/rx) (25°C)	/	/	1.3	1.8
Group delay ripple	ns	/	3.0	/
Max insertion loss (-10~85°C)	dB	/	/	/
Input port impedance	Ohm	/	50	/
Output port impedance	Ohm	/	50	/
EVM	/	/	/	/
Group delay	ns	/	3	/
Amplitude balance(for balance Type)	dB	/	/	/
Phase balance(for balance Type)	°	/	/	/
Absolute attenuation(dB)	10-824MHz	35	45	/
	824-915 MHz	35	42	/

	825-960 MHz	35	42	/
	1427-1463 MHz	25	35	/
	1710-1785MHz	25	32	/
	1850-2025MHz	30	38	/
	2300-2690 MHz	32	45	/
	3400-3800 MHz	30	46	/
	4400-4900 MHz	30	40	/
	5150-5925 MHz	25	35	/
2nd harmonics	dBm	/	/	-40
3rd harmonics	dBm	/	/	-40
Other higher-order harmonics( $\leq 12.75G$ )	dBm	/	/	-40
2nd harmonics	dBm	/	/	-36
3rd harmonics	dBm	/	/	-36
Other higher-order harmonics( $\leq 12.75G$ )	dBm	/	/	-36
<i>ESD(HBM)@1301</i>	V	>100V		
<i>ESD(CDM)@1301</i>	V	>100V		
<i>Ambient Temperature</i>	°C	25		
<i>MSL</i>		3		
<i>Operating Temperature Range</i>	°C	-30	-	+85
<i>Operating Temperature Range</i> <i>Ta: Guarantee performance: -30°C~+85°C,</i> <i>Guarantee function: -40°C~-30°C</i>	°C	-40	-	+85
<i>Storage Temperature Range</i>	°C	-40	-	+85
<i>Package Size</i>	1.5*1.1, height 0.7 max			

**Notes:**

- 1) For every requirements' min value, type value and max value, if it is filled with "/", you can ignore it.
- 2) The temperature condition (no especially explanation) is all temperature.
- 3) The specification item is only for differential Rx application.
- 4) The bandwidth of amplitude ripple item is the max Channel bandwidth of each band.
- 5) All power levels are referenced to the antenna port. Two CW tones are applied at frequencies F1 and F2, and the resultant inter modulation product in the Rx band is measured. The first tone is applied to the Tx port in the range F1 at max input power (or +26 dBm). The second tone is -15 dBm applied to the antenna port at F2, with the following four cases:
  - a)  $F2 = \Delta F$
  - b)  $F2 = 2 * F1 - \Delta F$
  - c)  $F2 = F1 - \Delta F$
  - d)  $F2 = 3 * F1 + \Delta F$

F1= Frequency which is in TX band, for example, when duplexer is working at B2, the F1 is 1920-1980M.  
 $\Delta F$ =Frequency which is TX and RX different, when duplexer is working at B2, the F2 is 190MHz.
- 6) The test condition of harmonics item is as follows: The harmonics is measured at the Ant port with different VSWR (VSWR of Ant port  $\leq 4:1$ ), as the power ( $P_{in} = P_{max}$ , with CW for FDD TX filter, and LTE uplink signal 5MHz,1RB,50% duty cycle for TDD TX filter ) is applied to the TX port.

# Typical Performance

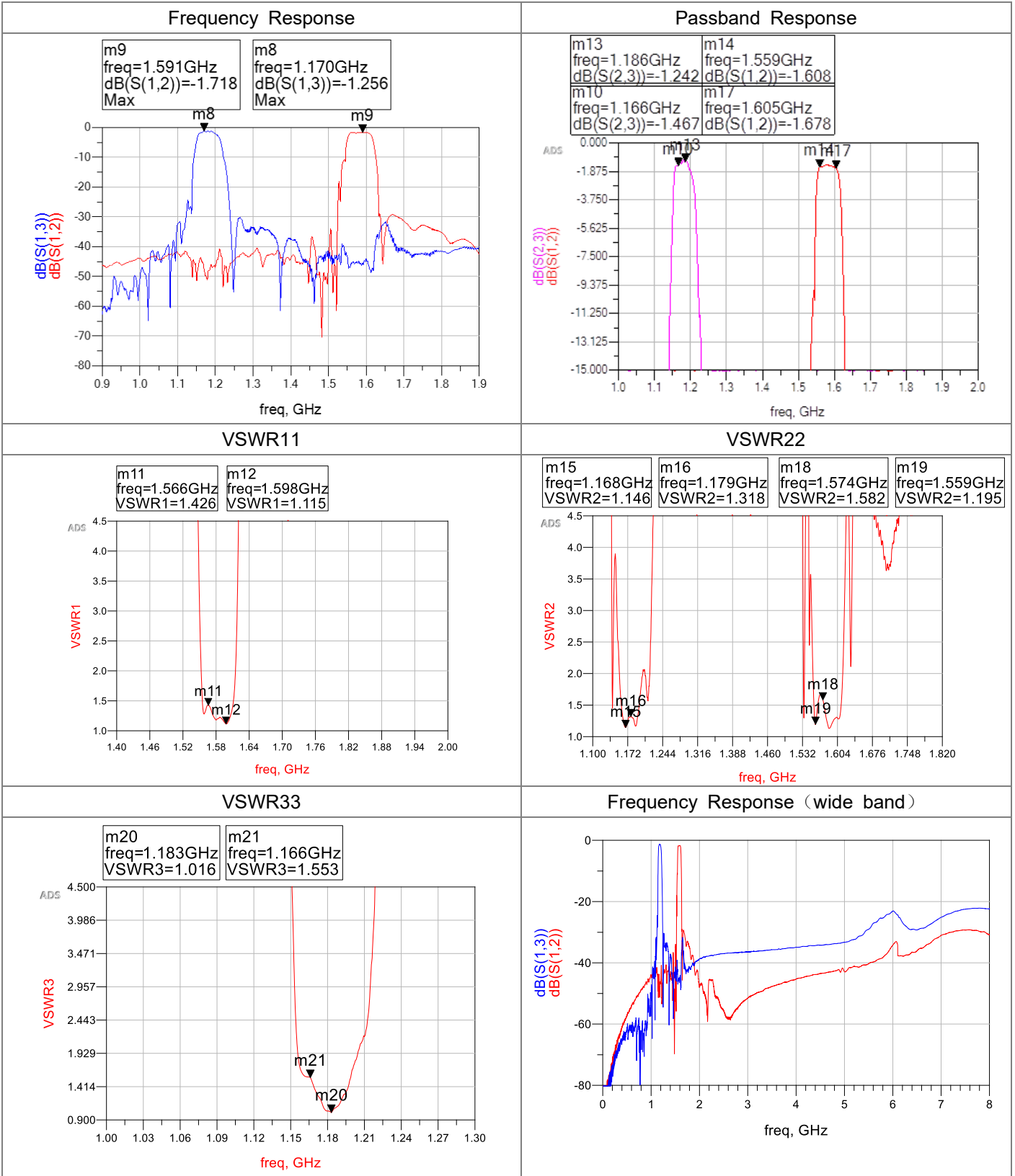

## Package Outline Dimensions

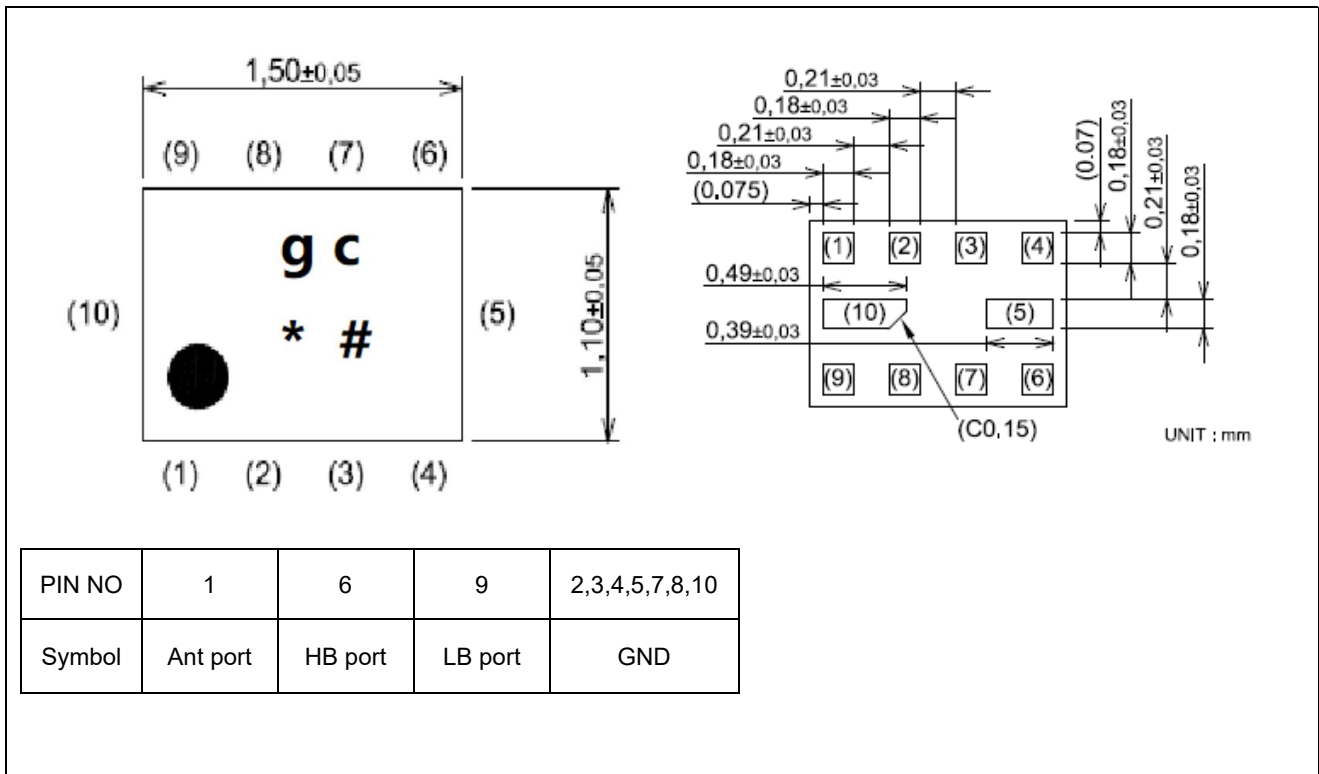

Figure 3 Package Outline Dimensions

### Marking Configuration:

- 1) g c: Internal Product Code
- 2) \* #: Date Code
- 3) • : Dot Marking

## Tape and Reel Dimensions

### ① Dimensions of Tape:

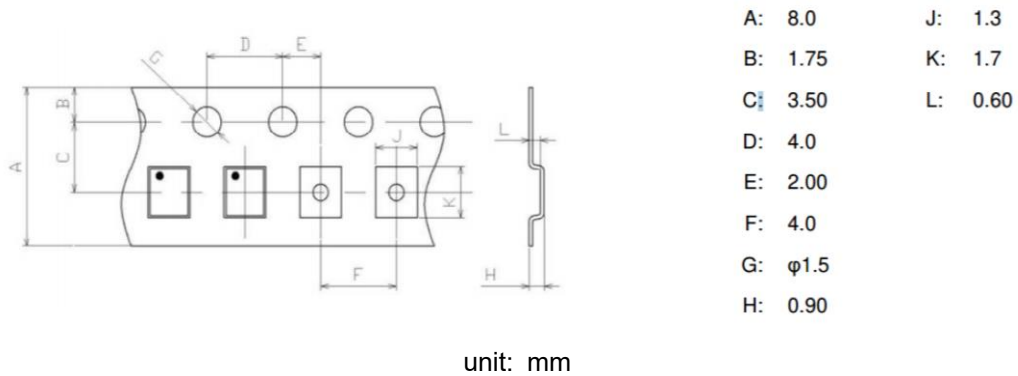

### ② Dimensions of Reel:

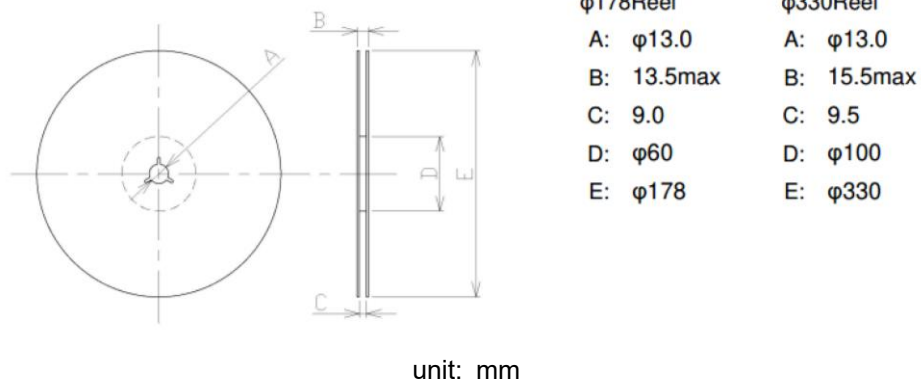

### ③ Taping figure and drawing direction:

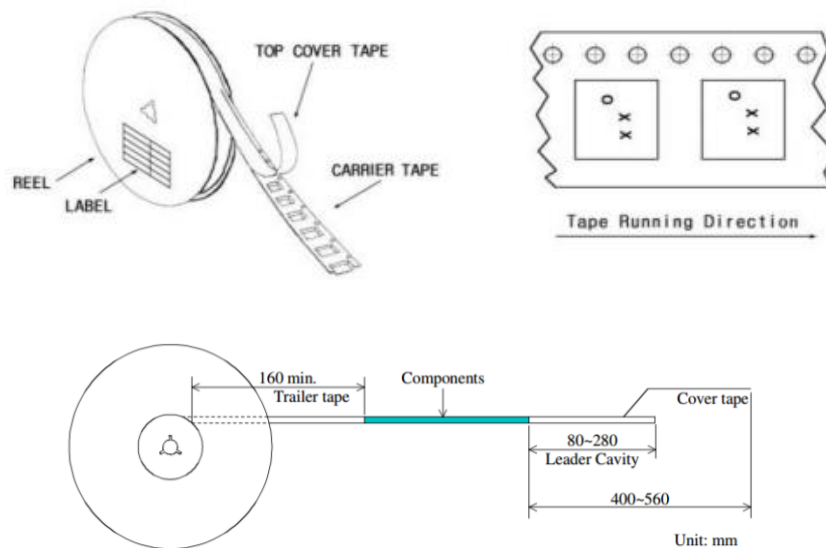

Figure 4 Tape and Reel Dimensions



## Reflow Chart

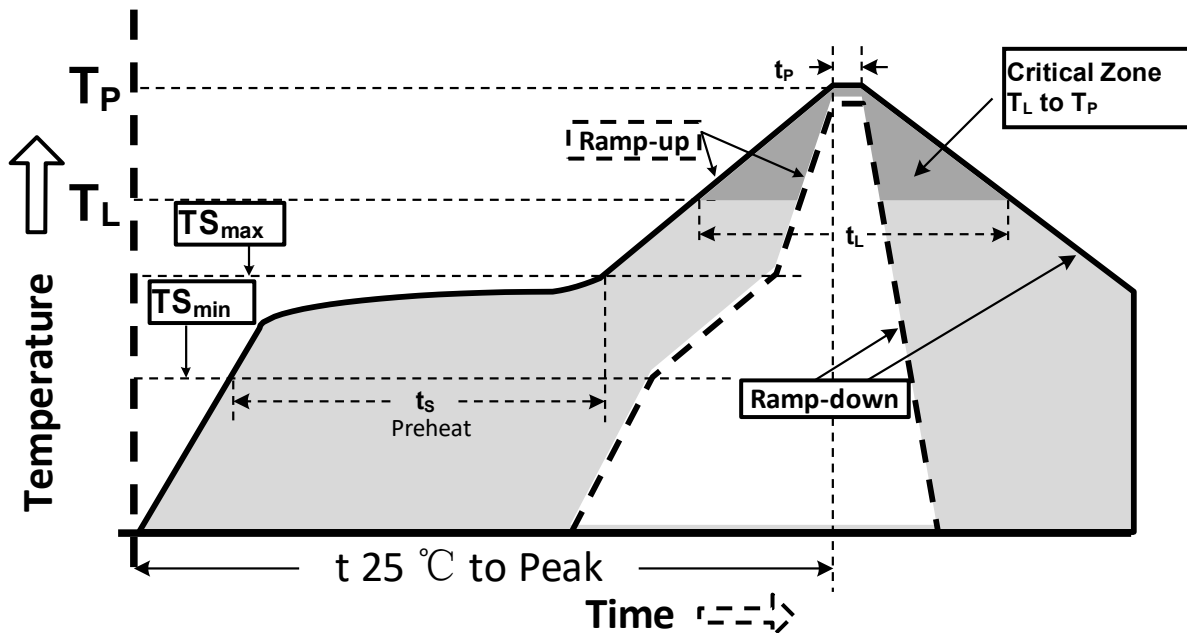

Figure 5 Recommended Lead-Free Reflow Profile

Table 5 Reflow condition

Profile Parameter	Lead-Free Assembly, Convection, IR/Convection
Ramp-up rate (TS <sub>max</sub> to T <sub>p</sub> )	3°C/second max.
Preheat temperature (TS <sub>min</sub> to TS <sub>max</sub> )	150°C to 200°C
Preheat time (t <sub>s</sub> )	60 - 180 seconds
Time above T <sub>L</sub> , 217°C (t <sub>L</sub> )	60 - 150 seconds
Peak temperature (T <sub>p</sub> )	260°C
Time within 5°C of peak temperature(tp)	20 - 40 seconds
Ramp-down rate	6°C/second max.
Time 25°C to peak temperature	8 minutes max.

## ESD Sensitivity

Integrated circuits are ESD sensitive and can be damaged by static electric charge. Proper ESD protection techniques should be used when handling these devices.

## RoHS Compliant

This product does not contain lead, mercury, cadmium, hexavalent chromium, polybrominated biphenyls (PBB) and polybrominated diphenyl ethers (PBDE), and are considered RoHS compliant.

## X-ON Electronics

Largest Supplier of Electrical and Electronic Components

*Click to view similar products for [SAW Oscillators](#) category:*

*Click to view products by [Suntek](#) manufacturer:*

Other Similar products are found below :

[XG-2102CA 100.0000M-LGPAL3](#) [XG-2102CA 156.2500M-LGPAL3](#) [CCSO-914XL-500.000](#) [XG-2102CA 125.0000M-PHPA](#) [SK3530H](#)  
[B21D339210A010CT](#) [EG-2121CA 100.0000M-LHPAB](#) [EG-2121CA 125.0000M-LGPNB](#) [EG-2121CA 125.0000M-LHPAB](#) [EG-2121CA](#)  
[125.0000M-PHPAL3](#) [CVCSO-914-1000](#) [CCSO-914X-1000](#) [CVCSO-914XL-1000.000](#) [S1614E-25.0000\(T\)](#) [EG-2121CA 100.0000M-](#)  
[LGPAL3](#) [EG-2121CA 125.0000M-LGRNLX](#) [EG-2121CA 125.0000M-LHPAL3](#) [EG-2121CA 200.0000M-LHPAB](#) [EG-2121CA 200.0000M-](#)  
[LHPAL3](#) [EG-2121CA 200.0000M-PHPAL3](#) [EG-2121CA 212.5000M-PHPAB](#) [EG-2121CA 312.5000M-LGPAB](#) [EG-2121CA 200.0000M-](#)  
[LGPAB](#) [XG-2102CA 312.5000M-LGRN](#) [XG-2102CA 200.0000M-LHPA](#) [VS-705-ECE-KAAN-155M520000](#) [VS-705-ECE-KAAN-](#)  
[983M040000](#) [VS-705-ECE-SAAN-125M000000](#)