

# SK4153 28V 800mA Single Li-ion Battery Linear Charger

## GENERAL DESCRIPTION

The SK4153 is a complete constant-current / constant voltage linear charger for single Lithium-Ion battery with high input voltage rating and large current. The largest input voltage is up to 28V and charge current is up to 800mA. The input over voltage protection threshold is 6.8V and the lowest input voltage is 3.75V, which can meet the requirement of voltage-adjustment to reduce charging power consumption and improve overall efficiency.

External isolation diodes are not required due to the internal PMOS architecture and anti-reverse charging circuit. Thermal feedback regulates the charge current to limit the die temperature during high power operation or high ambient temperature. The charge voltage is fixed at 4.0V/4.1V/4.15V/4.2V/4.35V/4.4V/4.45V, and the charge current can be programmed externally with a single resistor.

The SK4153 automatically terminates the charge cycle when the charge current drops to 1/10 the programmed value after the final float voltage is reached. When the input voltage (supplied by AC adapter or USB power supply) is removed, the SK4153 automatically enters a low current state, decreasing the battery leakage current to less than 1 $\mu$ A.

Other features of SK4153 include over temperature protection, under voltage lockout, automatic recharge and charging state indication (two LED pins to show charge state and charge-ending state).

## FEATURES

- Wide Input Voltage Range: 3.75V~28V
- Input Over Voltage Protection : 6.8V (Typ.)
- Programmable Charge Current up to 800mA
- Maximum BAT withstand voltage up to 20V
- Battery reverse connection protection
- No anti-backcharge MOSFETs, detection resistors, or isolation diodes are required
- Thermal Regulation to Maximize Charge Rate Without Risk of Overheating.
- 1% Charge Voltage Accuracy
- Charging status and fault status indication
- C/10 Termination Charge Current, automatically recharge
- Trickle charge threshold: 2.9V (Typ. Float Voltage: 4.2V)
- Soft-start and surge current limit
- Available in SOT23-5L, SOT23-6L Packages

## APPLICATIONS

- Standby power supply, portable power source
- Mobile phone, PDA, GPS
- MP3, MP4 player
- Digital camera, electronic dictionary
- Portable devices, Various chargers

## TYPICAL APPLICATION CIRCUIT

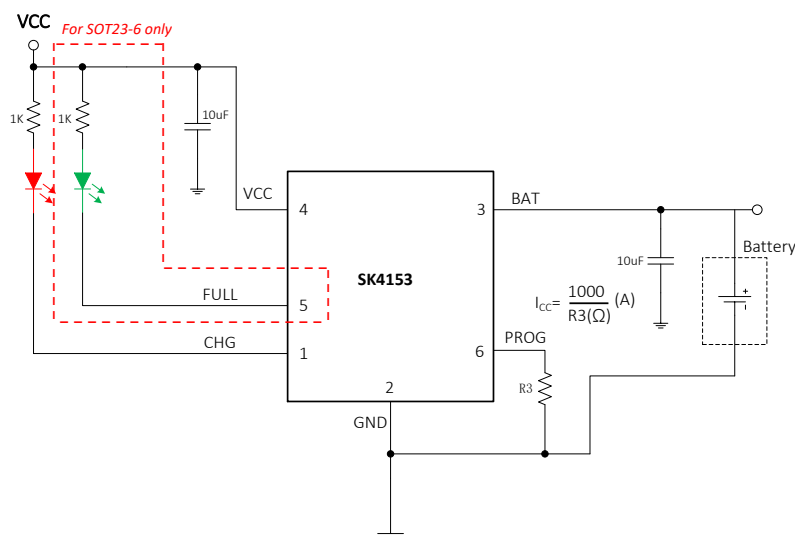

## PIN ASSIGNMENT

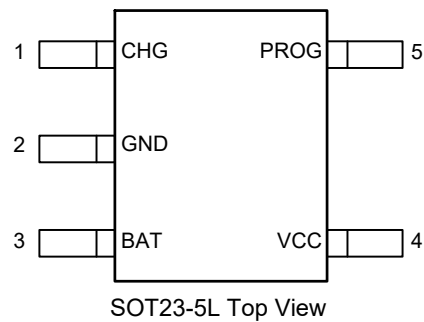
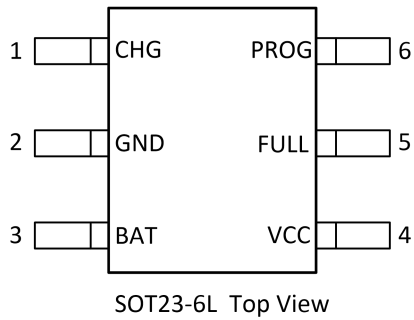

## PIN DESCRIPTION

Pin No.		Name	Input/Output	Function
SOT23-5L	SOT23-6L			
1	1	CHG	Output	Charge indicating terminal. When the battery is charging, the CHG pin is pulled low. Otherwise the CHG is forced high impedance.
2	2	GND	Ground	Ground
3	3	BAT	Output	Battery positive terminal connection
4	4	VCC	Input	Power supply
-	5	FULL	Output	Open-Drain Charge termination indicated pin. When charge is terminated, it is pulled low, otherwise it is high impedance.
5	6	PROG	Output	Charge current setting and charge current monitor

## ORDERING INFORMATION

Part No.	Package	V <sub>FLOAT</sub>	Temperature	Tape & Reel
SK4153S6-40	SOT23-6L	4.0V	-40~85°C	3000
SK4153S6-41		4.1V		3000
SK4153S6-415		4.15V		3000
SK4153S6-42		4.2V		3000
SK4153S6-435		4.35V		3000
SK4153S6-44		4.4V		3000
SK4153S6-445		4.45V		3000
SK4153S5-42	SOT23-5L	4.2V	-40~85°C	3000
SK4153S5-435		4.35V		3000
SK4153S5-44		4.4V		3000
SK4153S5-445		4.45V		3000

## MARKING DESCRIPTION

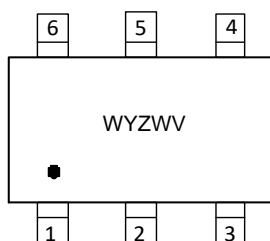

W: Product Code  
 YZ: Internal Control Code  
 W: Code of Production Week  
 V: Voltage Version

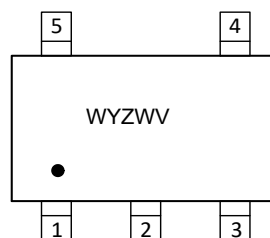

W: Product Code  
 YZ: Internal Control Code  
 W: Code of Production Week  
 V: Voltage Version

## ABSOLUTE MAXIMUM RATINGS (Note 1)

SYMBOL	ITEMS	VALUE	UNIT
V <sub>CC</sub>	Input voltage	-0.3~28	V
V <sub>BAT</sub>	BAT voltage	-5~20	V
V <sub>CHG</sub> , V <sub>FULL</sub>	CHG/FULL voltage	-0.3~28	V
V <sub>PROG</sub>	PROG Voltage	-0.3~7	V
I <sub>BAT</sub>	BAT Pin Current	1000	mA
P <sub>DMAX</sub>	Maximum Power Dissipation	0.5	W
R <sub>θJA</sub>	Junction to Ambient Thermal Resistance	270	°C/W
T <sub>J</sub>	Junction Temperature	-40~150	°C
T <sub>A</sub>	Ambient Temperature	-40~85	°C
T <sub>STG</sub>	Storage Temperature	-55~150	°C
T <sub>SOLDER</sub>	Soldering Temperature	260°C, 10s	

Note 1: Stresses beyond those listed under "Absolute Maximum Ratings" may cause permanent damage to the device. Exposure to absolute maximum rating conditions for extended periods may affect device reliability.

## RECOMMENDED OPERATING CONDITION

Symbol	Description	Min.	Typical	Max	Units
V <sub>CC</sub>	Input Voltage Range	3.75		25	V
I <sub>BAT</sub>	Charge Current Range	100		800* <sup>Note2</sup>	mA
R <sub>PROG</sub>	charge current programming resistor	1.25		10	KΩ

Note 2: To meet the maximum charging current, the power consumption PD of the chip should be controlled within 0.8W. At normal indoor temperature, the PCB has good heat dissipation, and  $V_{CC} \geq V_{BAT} + V_{DROP}$ . Chip power consumption  $P_D = (V_{CC} - V_{BAT}) * I_{CC}$ . V<sub>DROP</sub> ranges from 0.6V to 0.9V@800mA, V<sub>BAT</sub> from 3V to 4.2V. Generally, the V<sub>CC</sub>-V<sub>BAT</sub> is controlled within the range of V<sub>DROP</sub> ~1V to meet the charging demand of the maximum current. There is a temperature loop inside the chip that keeps the temperature of the chip from exceeding 130°C. If the temperature reaches 120°C (typical), the chip starts to reduce the I<sub>BAT</sub> current to ensure that the chip is not overheated. The reduction of V<sub>CC</sub> voltage can be achieved by series connecting power resistors; If V<sub>CC</sub> is a controlled voltage source, setting V<sub>CC</sub> to track V<sub>BAT</sub> voltage can maximize charging current and efficiency.

## ELECTRICAL CHARACTERISTICS

The following specifications apply for  $V_{CC}=5V$   $T_A=25^{\circ}C$ , unless specified otherwise.

SYMBOL	PARAMETER	CONDITIONS	MIN	TYP.	MAX	UNITS	
$V_{CC}$	Input Supply Voltage		3.75	5	25	V	
$I_{CC}$	Input Supply Current	Charging mode, $R_{PROG} = 10K$	96	100	104	mA	
		Charging mode, $R_{PROG} = 2K$	460	500	540	mA	
		Charging mode, $R_{PROG} = 1.25K$	720	800	880	mA	
		Standby Mode (charging termination) $V_{BAT}=4.5V$		155		$\mu A$	
		OVP, $V_{CC}=7V$		75		$\mu A$	
		ASD, $V_{CC}=V_{BAT}=4V$		110		$\mu A$	
		OTP, $V_{CC}=5V$		200		$\mu A$	
		UVLO, $V_{CC}=3.3V$		60		$\mu A$	
$V_{FLOAT}$	Float Voltage	$I_{BAT} = 30mA, R_{PROG} = 10K$	3.960	4.0	4.040	V	
			4.059	4.1	4.141	V	
			4.108	4.15	4.191	V	
			4.158	4.2	4.242	V	
			4.306	4.35	4.394	V	
			4.356	4.4	4.444	V	
			4.405	4.45	4.495	V	
$I_{BAT}$	BAT Pin Current	Charging mode ( $R_{PROG} = 10K$ )	96	100	104	mA	
		Charging mode ( $R_{PROG} = 2K$ )	460	500	540	mA	
		Charging mode ( $R_{PROG} = 1.25K$ )	720	800	880	mA	
		Standby Mode (charging termination) $V_{BAT}=4.5V$		4		$\mu A$	
		OVP, $V_{CC}=7V$		0	1	$\mu A$	
		ASD, $V_{CC}=V_{BAT}=4V$		2		$\mu A$	
		OTP, $V_{CC}=5V$		10		$\mu A$	
		UVLO, $V_{CC}=3.3V$		0	1	$\mu A$	
$I_{TRIKL}$	C/10 Trickle Charge Current	$V_{BAT} < V_{TRIKL}, R_{PROG} = 10K$	9	10	11	mA	
		$V_{BAT} < V_{TRIKL}, R_{PROG} = 2K$	46	50	54	mA	
		$V_{BAT} < V_{TRIKL}, R_{PROG} = 1.25K$	72	80	88	mA	
$V_{TRIKL}$	Trickle Charge Threshold Voltage	$R_{PROG}=2K,$ $V_{BAT}$ Rising	4.0V Version	2.7	2.81	3.1	V
			4.1V Version	2.7	2.84	3.1	
			4.15V Version	2.7	2.87	3.1	
			4.2V Version	2.7	2.9	3.1	
			4.35V Version	2.7	2.94	3.1	
			4.4V Version	2.7	2.97	3.1	
			4.45V Version	2.7	3.08	3.15	
$V_{TRHYS}$	Trickle Charge Hysteresis Voltage	$R_{PROG} = 2K$		100		mV	
$V_{UV}$	$V_{CC}$ UVLO Threshold	$V_{CC}$ from low to high	3.25	3.4	3.75	V	

SYMBOL	PARAMETER	CONDITIONS	MIN	TYP.	MAX	UNITS
$V_{UVHYS}$	$V_{CC}$ UVLO Hysteresis			200		mV
$V_{ASD}$	$V_{CC}-V_{BAT}$ Lockout Threshold Voltage	$V_{CC}$ rising, $R_{PROG}=10K$		300		mV
		$V_{CC}$ dropping, $R_{PROG}=10K$		150		mV
$I_{TERM}$	C/10 Termination Current Threshold	$R_{PROG}=10K$	9	10	11	mA
		$R_{PROG}=2K$	46	50	54	mA
		$R_{PROG}=1.25K$	72	80	88	mA
$V_{PROG}$	PROG Pin Voltage	$R_{PROG}=2K$ , Charging Mode		1.5		V
$V_{CHG}$	CHG Pin Output Low Voltage	$I_{CHG}=5mA$			0.4	V
$V_{FULL}$	FULL Pin Output Low Voltage	$I_{FULL}=5mA$			0.4	V
$\Delta V_{RECHRG}$	Recharge Battery Threshold Voltage	$V_{FLOAT}-V_{RECHRG}$		130		mV
$T_{LIM}$	The junction temperature in the defined temperature mode			130		°C
OVP	Input over-voltage protection(rising)		6.7	6.8	7.1	V
	OVP Threshold Hysteresis			250		mV
OTP	Over Temperature Protection			150		°C
$t_{RECHARGE}$	Recharge Comparator Filter Time	$V_{BAT}$ from high to low		1		ms
$t_{TERM}$	Charge Terminated Comparator Filter Time	$I_{BAT}$ drops below $I_{CHG}/10$		1		ms
$t_{SS}$	Soft-start Time			120		μs

## TYPICAL CHARACTERISTICS

**IBAT vs VBAT**

( $V_{CC}=5V$ ,  $R_{PROG}=10K$ )

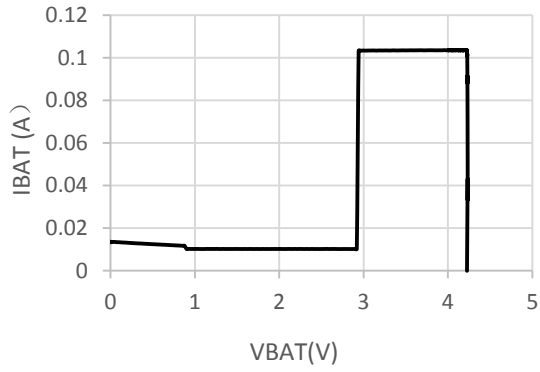

**IBAT vs VBAT**

( $V_{CC}=5V$ ,  $R_{PROG}=2K$ )

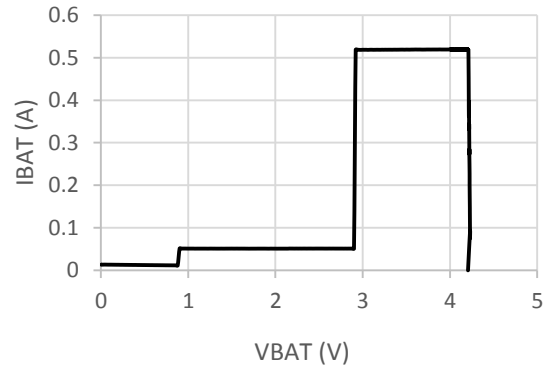

**IBAT vs VCC**

( $V_{BAT}=3.2V$ ,  $R_{PROG}=10K$ )

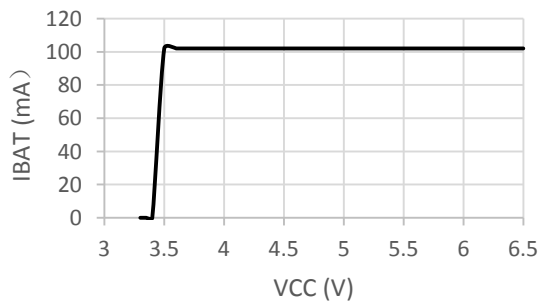

**IBAT vs VCC**

( $V_{BAT}=3.2V$ ,  $R_{PROG}=2K$ )

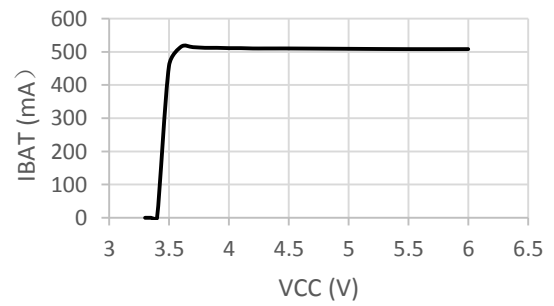

**V<sub>FLOAT</sub> vs V<sub>CC</sub>**  
( $R_{PROG}=10K$ ,  $I_{BAT}=30mA$ )

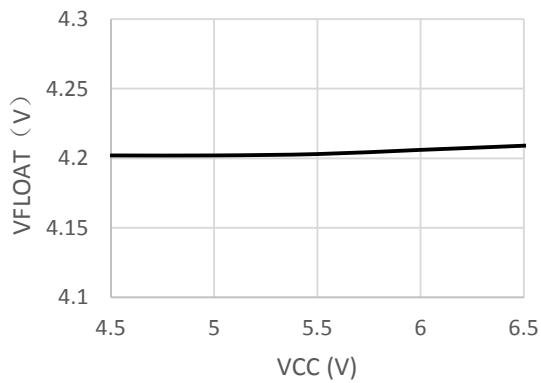

**V<sub>FLOAT</sub> vs V<sub>CC</sub>**  
( $R_{PROG}=2K$ ,  $I_{BAT}=80mA$ )

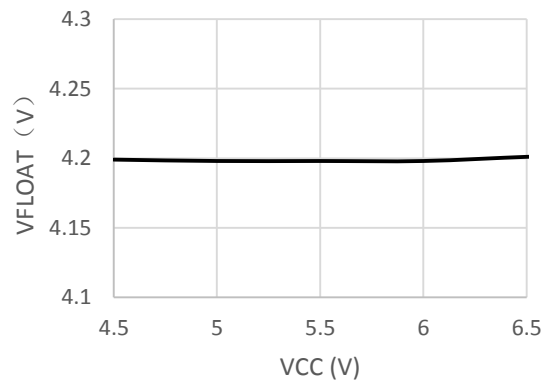

## FUNCTION BLOCK DIAGRAM

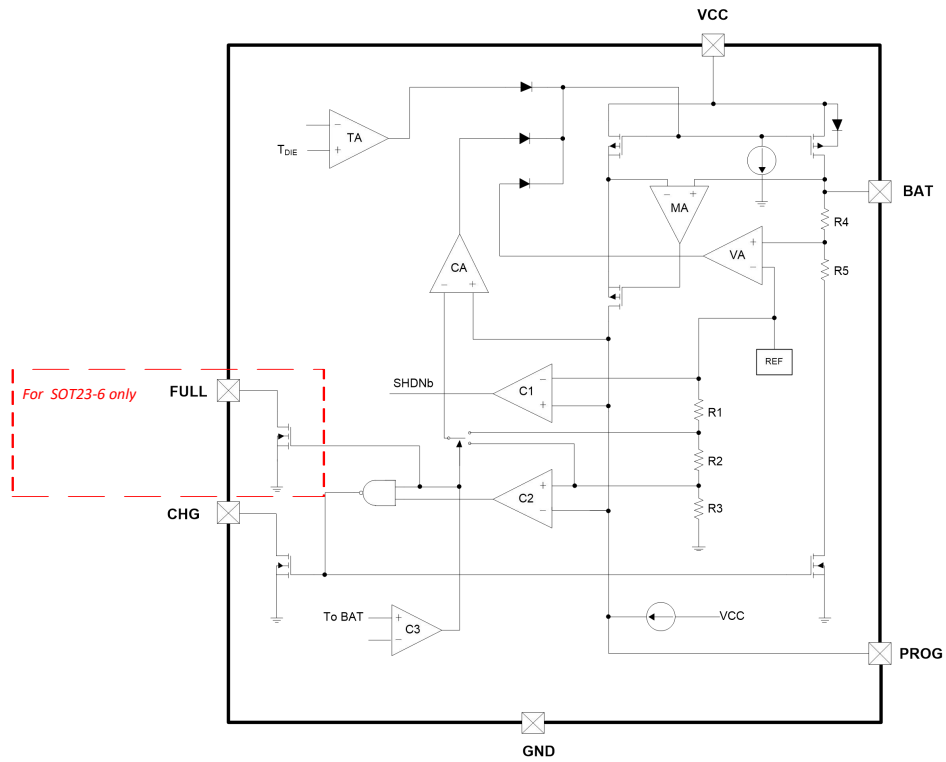

## TYPICAL COMPLETED CHARGING CURVE

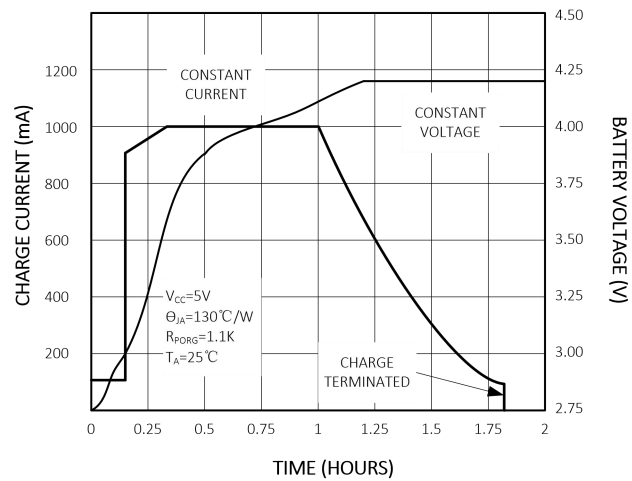

## APPLICATION INFORMATIONS

The SK4153 is a single cell Li-Ion battery linear charger using a constant-current/constant-voltage algorithm. Charging current can be programmed with an external resistor and maximum continuous charging current is up to 800mA.

The SK4153 SOT23-5 package contains one open-drain indicator for the charge status indication, CHG pin (charging status). And SOT23-6 package contains two open-drain indicators for the charge status indication, one is CHG (charging status), and the other is FULL (full-charged status). FULL can be also used to indicate fault status.

Inner temperature management circuit can automatically decrease charging current when Junction Temperature is over TLIM. This function can maximize the load capacity of the chip and prevent the damage to chip or external component caused by over-temperature.

The SK4153 begins a charge cycle when the voltage at the VCC pin rises above the UVLO threshold level. Thus, the CHG pin is pulled low, which means charging is in progress. If the BAT pin is less than the  $V_{TRIKL}$ , the charger enters trickle charge mode. When the BAT pin voltage rises above the  $V_{TRIKL}$ , the charger enters constant-current mode, and the charge current is programmed by R<sub>PROG</sub> between PROG pin and GND. When the BAT pin approaches the final float voltage, the SK4153 enters constant-voltage mode and the charge current begins to decrease. The charging cycle terminates when the charging current drops to charging-over threshold. Under this condition, output of CHG is in high-impedance state while output of FULL is in low potential.

Charging-over threshold is 10% of constant charging current. A new charging cycle is started when battery voltage drops below recharging voltage threshold. High-accuracy inner reference voltage source makes sure a float voltage accuracy of 1%, which meets the requirements of Li-ion and Li-polymer battery.

The charger enters sleeping mode with low power consumption when input voltage drops or lower than battery voltage. In this mode, current consumed by battery is lower than 1uA, which helps to increase standby time.

### Input Over-voltage Protection

The SK4153 has built-in input voltage surge protection as high as +28V. The charger cycle will be automatically shut down when the input voltage is higher than 6.8V to avoid high-voltage damage and reworks when input voltage is below 6.8V.

### Setting of Charging Current

The charge current is set by a resistor connecting between the PROG pin and GND. The relationship of the charging current and the programming resistance is established by the following equations:

$$R_{PROG} = \frac{1000}{I_{BAT}}$$

In applications, R<sub>PROG</sub> could be selected according to requirements. Relationship between R<sub>PROG</sub> and charge current could be as follow:

R <sub>PROG</sub> (K)	I <sub>BAT</sub> (mA)
10	100
5	200
3.33	300
2.5	400
2	500
1.67	600
1.43	700
1.25	800

### Charging Termination

A charge cycle is terminated when the charge current falls to 1/10 the programmed value after the final float voltage is reached. When the time that PROG



pin voltage falls below 150mV (typ.) is longer than  $T_{TERM}$  and charging cycle is terminated. Then SK4153 enters standby mode, and input current drops to 155uA (typ.).

The chip has designed the function of preventing the false turn off caused by the load transient jump. 1ms  $T_{TERM}$  on Terminating Comparator prevents the early termination caused by load transient. Once the average charging current drops to 1/10 of the preset value and ends the charge cycle. No more current is outputted to BAT. Under this state, all load of BAT is powered by battery.

In standby mode, SK4153 keeps monitoring voltage of BAT pin. When BAT pin voltage drops below  $V_{RECHRG}$  (recharge threshold Voltage), another charge cycle starts and supplies current to power again.

Pic 1 shows a typical charging cycle:

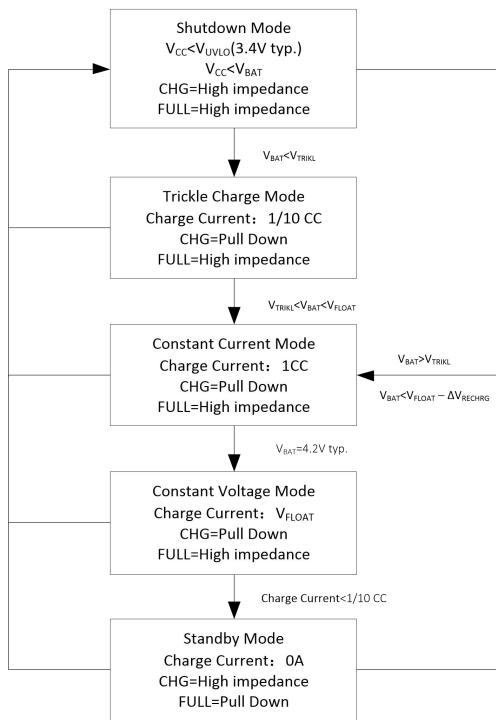

Pic 1:A typical charging cycle

### Charging Status Indicator (CHG and FULL)

SK4153 has two different open-drain status outputs of charge status, one is CHG, and the other

is FULL(SOT23-6 only). If those two outputs are connected to LED light, light goes on when the pin pulled low and light goes off when high impedance.

No-battery pulse signal is outputted by CHG pin if battery is not connected to charger. When the external capacitance of BAT pin connected to battery is 10uF, flash frequency of CHG is 1-4s. The output of status indicator should be connected to GND, when status indicator function is not used.

Refer to the following table for the function of status indication:

PIN	STATUS	FULL	CHG	Description
VCC	$V_{CC} < V_{UVLO}$	OFF	OFF	Fault
	$V_{CC} - V_{BAT} < V_{ASD}$	OFF	OFF	Fault
	$V_{ASD} \leq V_{CC} < OVP$	OFF	ON	Charging
	$V_{CC} \geq OVP$	OFF	OFF	Fault
	VCC Floating	OFF	OFF	No-charging
VBAT	$V_{BAT} < V_{TRIKL}$	OFF	ON	Charging
	$V_{BAT} \geq V_{TRIKL}$	OFF	ON	Charging
	$V_{BAT} > V_{ASD}$	OFF	OFF	Fault
	BAT short-circuit	OFF	ON	Charging
	BAT Floating	Flash	Flash	No battery
IBAT	$I_{BAT} = 0$	ON	OFF	Charging End
	$0 < I_{BAT} < 1/10C$	Flash	Flash	No battery
	$I_{BAT} > 1/10C$	OFF	ON	Charging
PROG	PROG floating, then VCC powers on	OFF	OFF	Fault
	PROG floating when charging	OFF	ON	Current interruption
	PROG short circuit, then VCC powers on	OFF	OFF	Fault
	PROG short circuit during charging	Slightly light	ON	Fault

### Thermal Limit

If the chip temperature is above preset  $T_{LIM}$ , an inner thermal reflective circuit will decrease charging current. This function can prevent SK4153 from overheating and damage caused by increase load capacity. Charging current can be set according to typical (not the worst) ambient temperature on the premise that the charger will automatically reduce the current under the worst conditions.

### Under-voltage Protection

Build-in under voltage lockout circuit monitors the input voltage and keeps the charger in shutdown mode until VCC rises above the under-voltage lockout threshold. If the UVLO comparator is tripped, the charger will not come out of shutdown mode until VCC rises above the battery voltage, which should reach  $V_{ASD}$  at least.

### Manual shutdown

At any time in the charging cycle, SK4153 can be placed in the paused charging mode by removing  $R_{PROG}$  (making the PROG pin float). At this time, the charging current will decrease to 0, but the state of the charging indicator will not change; Reconnecting the setting resistor initiates a new charging cycle. In this manual shutdown mode, there is only a small leakage current at the BAT end.

If SK4153 is in under-voltage protection mode, the CHG and FULL pins are in high impedance state. The condition for this mode to enter is that the voltage which VCC exceeds the BAT pin voltage is less than the  $V_{ASD}$ , or the voltage on the VCC pin is below the UVLO threshold.

### Automatically Recharge

Once the charging cycle is terminated, the SK4153 uses a filtering time Comparator ( $t_{RECHARGE}$ ) to monitor the voltage on the BAT pin. Once battery voltage drops below  $\Delta V_{RECHRG}$  (Almost 80% to 90%

of Battery capacity), charging cycle reworks, which makes sure the battery is kept in full-charged (or almost full-charged) state and avoids starting a periodic charging cycle. In recharging cycle, the output of CHG pin enters a strong pull-down state.

### Thermal Design

Due to the small package dimension of SOT23-6, an elaborate thermal design of PCB layout, which is used for increasing usable charging current to maximum extent, is very important. The heat radiation circuit, used to dissipate the heat generated by IC, runs from chip to lead frame, and arrives PCB copper foil (which is an auxiliary radiator) through radiator below. The measure of copper foil, connected to radiator, should be as large as possible and stretch out to external larger copper foil to spread the heat to surrounding environment. The holes placed on the middle layer or back copper foil layer are also useful in improving the overall thermal performance of the charger. When designing PCB layout, other heat sources the circuit board not related to the charger must also be considered. Because they will also have an impact on the overall temperature rise and the maximum charging current.

### Soft Start for Charging Current

A soft-start circuit is designed to decrease inrush current to maximum extent at the beginning of charging cycle. When a charging cycle starts, the charging current will rise from 0 to the max in around  $120\mu s$ , which can decrease the load of transient current to the maximum.

### Protection of Reverse Connection of Battery

In SK4153, a reversed-connection protection circuit is designed to avoid the damage to chips caused by reverse connection of battery during production and assembly.

## PACKAGE OUTLINE

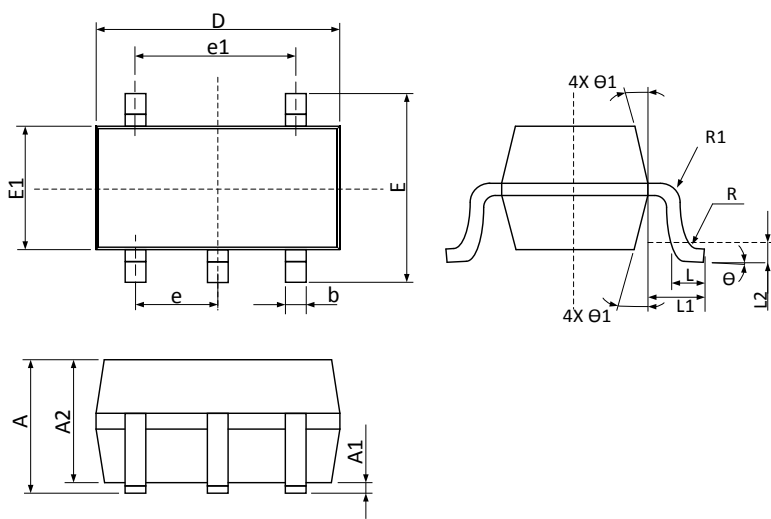
Package	SOT23-5L	Devices per reel	3000Pcs	Unit	mm
Package Dimension:					
					
Unit: mm					
SYMBOL	MIN	TYP.	MAX		
A	-	-	1.35		
A1	0.00	-	0.15		
A2	1.00	1.10	1.20		
b	0.35 REF				
D	2.82	2.92	3.02		
E	2.60	2.80	3.00		
E1	1.50	1.60	1.70		
e	0.95 REF				
e1	1.90 REF				
L	0.30	0.45	0.60		
L1	0.60 REF				
L2	0.25 REF				
R	0.10	-	-		
R1	0.10	-	0.25		
θ	0°	4°	8°		
θ1	5°	10°	15°		

## PACKAGE OUTLINE

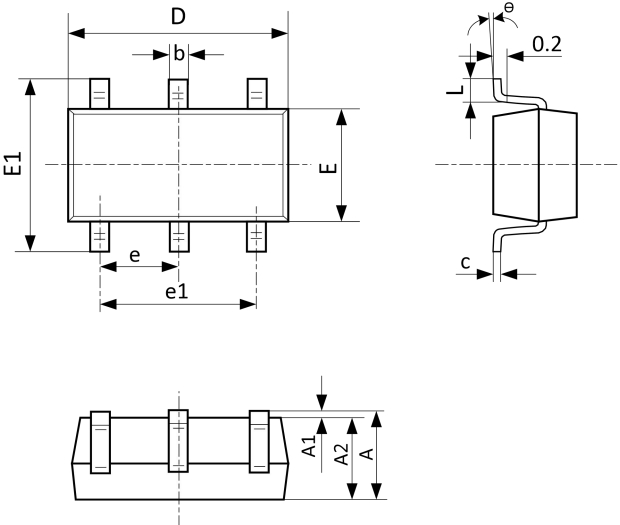
Package	SOT23-6L	Devices per reel	3000Pcs	Unit	mm
Package Dimension:					
					
SYMBOL	Unit:mm		Unit: Inch		
	Min	Max	Min	Max	
A	1.050	1.250	0.041	0.049	
A1	0.000	0.100	0.000	0.004	
A2	1.050	1.150	0.041	0.045	
b	0.300	0.400	0.012	0.016	
c	0.100	0.200	0.004	0.008	
D	2.820	3.020	0.111	0.119	
E	1.500	1.700	0.059	0.067	
E1	2.650	2.950	0.104	0.116	
e	0.950 TYP		0.037 TYP		
e1	1.800	2.000	0.071	0.079	
L	0.700 REF		0.028 REF		
L1	0.300	0.600	0.012	0.024	
$\theta$	0°	8°	0°	8°	

## X-ON Electronics

Largest Supplier of Electrical and Electronic Components

*Click to view similar products for [Battery Management](#) category:*

*Click to view products by [Suntek](#) manufacturer:*

Other Similar products are found below :

[NCP1851BFCCT1G](#) [NCP1855FCCT1G](#) [FAN54063UCX](#) [MP2615GQ-P](#) [LC05132C01NMTTTG](#) [ISL95522HRZ](#) [BD8665GW-E2](#)  
[ISL9538HRTZ](#) [ISL95522AIRZ](#) [S-82D1AAA-A8T2U7](#) [S-8224ABA-I8T1U](#) [MP2615CGQ-P](#) [ISL6251HRZ](#) [ISL6253HRZ](#) [ISL6292-2CR3](#)  
[ISL6292BCRZ-T](#) [ISL6299AIRZ](#) [ISL9211AIRU58XZ-T](#) [ISL9214IRZ](#) [ISL9220IRTZ-T](#) [FAN54161UCX](#) [SY6982CQDC](#)  
[IP6566\\_AC\\_30W\\_ZM](#) [WS3221C-6/TR](#) [ADBMS1818ASWAZ-RL](#) [ADBMS6815WCSWZ](#) [ML5245-005AMBZ07CX](#) [BQ25672RQMR](#)  
[ADBMS1818ASWZ-R7](#) [KA49503A-BB](#) [SC33771CTA1MAE](#) [BQ24060DRCR](#) [BQ7695202PFBR](#) [BQ21080YBGR](#) [BQ771809DPJR](#)  
[BQ24179YBGR](#) [BQ7693002DBTR](#) [TP4586](#) [FM2119L](#) [FM1623A](#) [DW01](#) [BQ25172DSGR](#) [DW01S](#) [TP4054](#) [MP2723GQC-0000-Z](#)  
[MP26124GR-Z](#) [MP2664GG-0000-Z](#) [XB5608AJ](#) [BQ25628ERYKR](#) [BQ25756RRVR](#)