

SK 6110C Synchronous Step-Up DC-DC Converter with PFM Control

Description

The SK6110C Series is a Synchronous step-up DC/DC Converter with PFM Control. With the SK6110C Series, a step-up switching DC/DC converter can be configured by using an external coil, capacitor. The built-in MOSFET is turned off by a protection circuit when the voltage at the LX pin exceeds the limit to prevent it from being damaged.

Applications

- Digital cameras
- Electronic notebooks and PDAS
- Portable CD/MD players
- Cameras, video equipment
- Communications equipment
- Power supply for microcomputers

Features

- External parts: Coil, capacitor
- Output voltage: Settable to between 2.1V to 5.5V in 0.1V steps
- Maximum Oscillation frequency :300KHz
- Accuracy of $\pm 2\%$
- High efficiency :95%
- Package: SOT23,SOT23-3,SOT23-5,SOT89 and TO92

Block Diagram

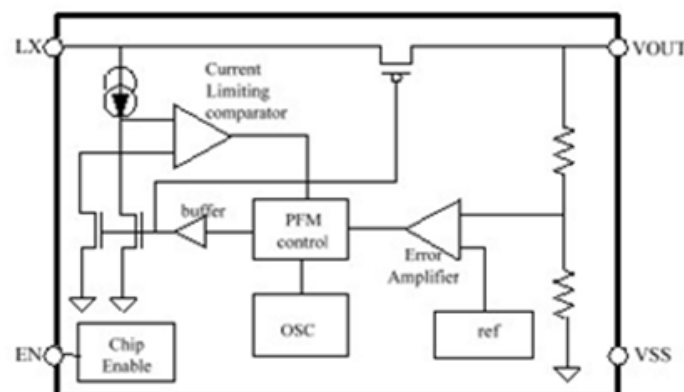

Ordering Information

SK6110C①②③④⑤

Designator	Symbol	Description
①	A	Standard
	B	Another pin definition
②③	Integer	Output Voltage (2.1~5.5) e.g:3.0V=②: 3; ③: 0
④	T	Package:TO-92
	P	Package:SOT89
	M	Package:SOT23-3
	M5	Package:SOT23-5
	N	Package:SOT23
⑤	R	RoHS / Pb Free
	G	Halogen Free

Pin Assignment

SOT23 and SOT23-3(Top view)

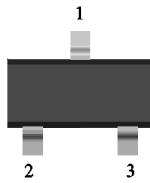

Table1 SK6110CA series (SOT23/SOT23-3 PKG)

PIN NO.	PIN NAME	FUNCTION
1	VOUT	Output voltage pin
2	GND	GND pin
3	LX	External inductor connection pin

SOT23-5(Top view)

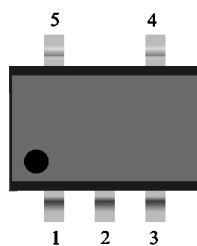

Table2 SK6110CA series (SOT23-5 PKG)

PIN NO.	PIN NAME	FUNCTION
1	EN	Shutdown pin "H": Normal operation "L": Step-up stopped
2	VOUT	Output voltage pin
3	NC	(N.C.)
4	GND	GND pin
5	LX	External inductor connection pin

SOT89 (Top view)

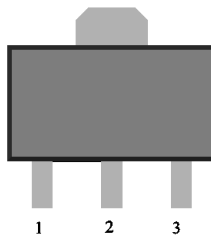

Table3 SK6110CA series (SOT89 PKG)

PIN NO.	PIN NAME	FUNCTION
1	GND	GND pin
2	VOUT	Output voltage pin
3	LX	External inductor connection pin

TO92 (Front view)

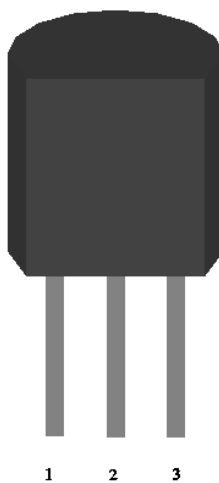

Table4 SK6110CA series (TO92 PKG)

PIN NO.	PIN NAME	FUNCTION
1	GND	GND pin
2	VOUT	Output voltage pin
3	LX	External inductor connection pin

Table5 SK6110CB series (TO92PKG and SOT23PKG)

PIN NO.	PIN NAME	FUNCTION
1	VOUT	Output voltage pin
2	GND	GND pin
3	LX	External inductor connection pin

Marking Rule

① product code: B stand for normal pin definition
C stand for different pin definition

② product code: 1

③ output voltage code:

Symbol	Voltage (V)	Symbol	Voltage (V)	Symbol	Voltage (V)	Symbol	Voltage (V)
a	0.9	A	3.5	n	2.2	N	4.8
b	1.0	B	3.6	o	2.3	O	4.9
c	1.1	C	3.7	P	2.4	P	5.0
d	1.2	D	3.8	q	2.5	Q	5.1
e	1.3	E	3.9	r	2.6	R	5.2
f	1.4	F	4.0	s	2.7	S	5.3
g	1.5	G	4.1	t	2.8	T	5.4
h	1.6	H	4.2	u	2.9	U	5.5
i	1.7	I	4.3	v	3.0	V	5.6
j	1.8	J	4.4	w	3.1	W	5.7
k	1.9	K	4.5	x	3.2	X	5.8
l	2.0	L	4.6	y	3.3	Y	5.9
m	2.1	M	4.7	z	3.4	Z	6.0

④⑤:

The last two of them are based on the time of this product which is the first time into production, the forth is the year of this product first time into production, such as expressed in "5" in 2015, in "6" in 2016 and the fifth is the month of this product first time into production, it can be in 1 ~ 9 , which is expressed in "0" in October, in November with an "A", in December with "B".

Absolute Maximum Ratings

(Unless otherwise specified, Ta=25°C)

PARAMETER		SYMBOL	RATINGS	UNITS
VOUT Pin Voltage		V _{OUT}	V _{SS} -0.3~V _{SS} +8	V
EN Pin Voltage		EN	V _{SS} -0.3~V _{SS} +8	V
LX Pin Voltage		V _{LX}	V _{SS} -0.3~V _{SS} +8	V
LX Pin Current		I _{LX}	1000	mA
Power Dissipation	SOT23	PD	250	mW
	SOT23-3/SOT23-5		250	mW
	SOT-89-3		500	mW
	TO-92		500	mW
Operating Temperature		T _{OPR}	-40~+85	°C
Storage Temperature		T _{STG}	-40~+125	°C
Soldering Temperature & Time		T _{SOLDER}	260°C, 10s	

Note: These are stress ratings only. Stresses exceeding the range specified under “Absolute Maximum Ratings” may cause substantial damage to the device. Functional operation of this device at other conditions beyond those listed in the specification is not implied and prolonged exposure to extreme conditions may affect device reliability.

Electrical Characteristics

(Unless otherwise specified, Ta = 25°C)

PARAMETER	SYMBOL	MIN	TYP	MAX	UNITS	CONDITION
Output Voltage	V _{OUT}	V _{OUT(S)} X0.98	V _{OUT}	V _{OUT(S)} X1.02	V	-
Input Voltage	V _{IN}	-	-	7.5	V	-
Operation Start Voltage	V _{ST1}	-	-	0.9	V	I _{OUT} =1mA, V _{OUT} =2.2V~4.2V
Operation Start Voltage	V _{ST2}	-	-	1.2	V	I _{OUT} =1mA, V _{OUT} =4.2V~5.5V
Input Current At No Load	I _{SS1}	-	15	25	uA	V _{IN} =1.8V, V _{OUT} =3.0V
		-	25	35	uA	V _{IN} =0.9V, V _{OUT} =3.0V
Current Consumption 2	I _{SS2}	-	6	10	uA	V _{OUT} =V _{OUT(S)} +0.5V
Current Consumption During Shutdown	I _{SS3}	-	-	1.0	uA	V _{EN} =0V
Maximum Oscillation Frequency	fosc		300		KHz	V _{OUT} =0.95xV _{OUT(S)} , measure Waveform at LX pin
Duty Ratio	Duty	70	78	85	%	V _{OUT} =0.95xV _{OUT(S)}
Efficiency	EFFI		90		%	
Shutdown Pin Input Voltage	V _{SH}	0.75	-	-	V	V _{OUT} =0.95xV _{OUT(S)} , judge Oscillation at LX pin
	V _{SL}	-	-	0.3	V	V _{OUT} =0.95xV _{OUT(S)} , judge stop at LX pin
Shutdown Pin input Current	I _{SH}	-0.1	-	0.1	uA	V _{EN} =6V
	I _{SL}	-0.1	-	0.1	uA	V _{EN} =0V

Remark: V_{OUT(S)} specified above is the set output voltage value, and V_{OUT} is the typical value of the actual output voltage

Application Circuits

1) SK6110C without CE

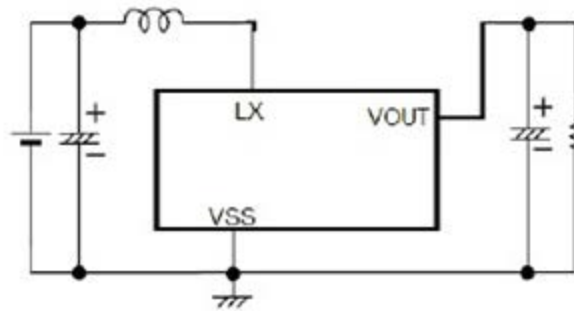

2) SK6110C with CE

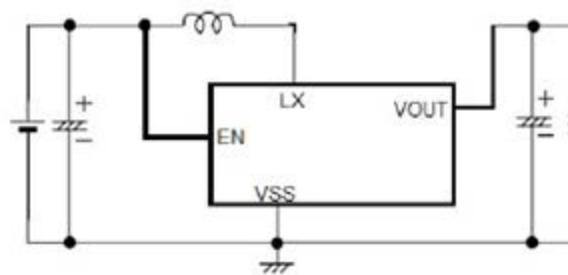

Note: External Component Recommendation:

- 1) $L=47\mu\text{H}$ (Sumida)
- 2) $C_F=100\mu\text{F}/16\text{V}$ (Tantalum)

TYPICAL PERFORMANCE CHARACTERISTICS

($C_{in}=C_{out}=100\mu F, L=47\mu H$)

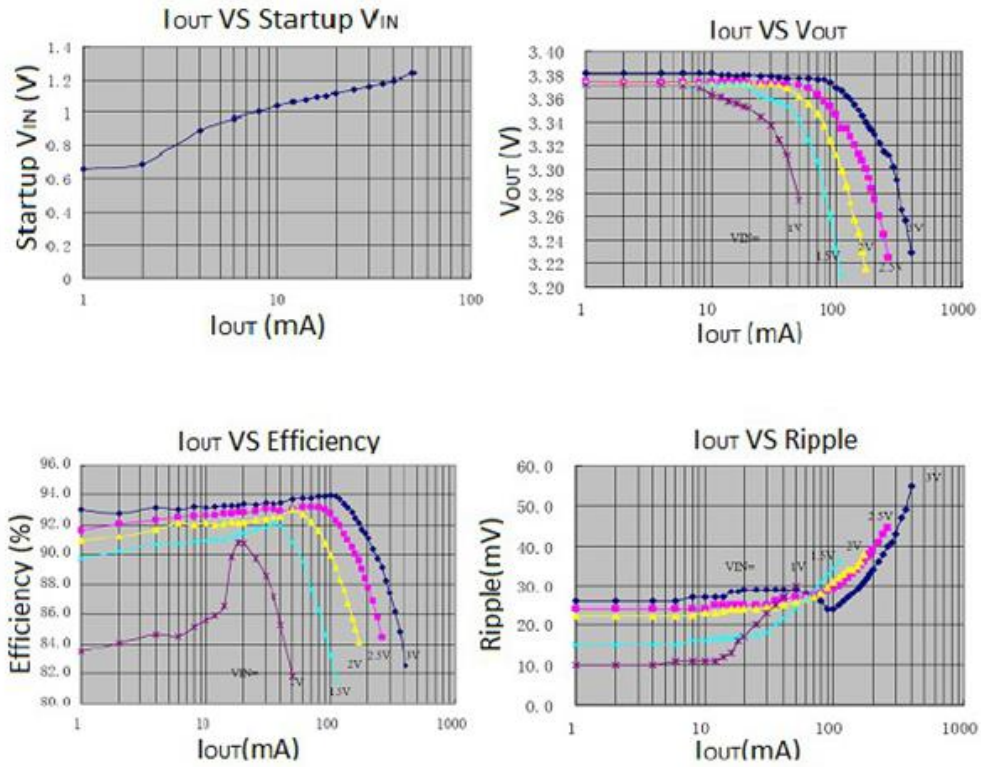

Package Information

3-pin SOT23 Outline Dimensions

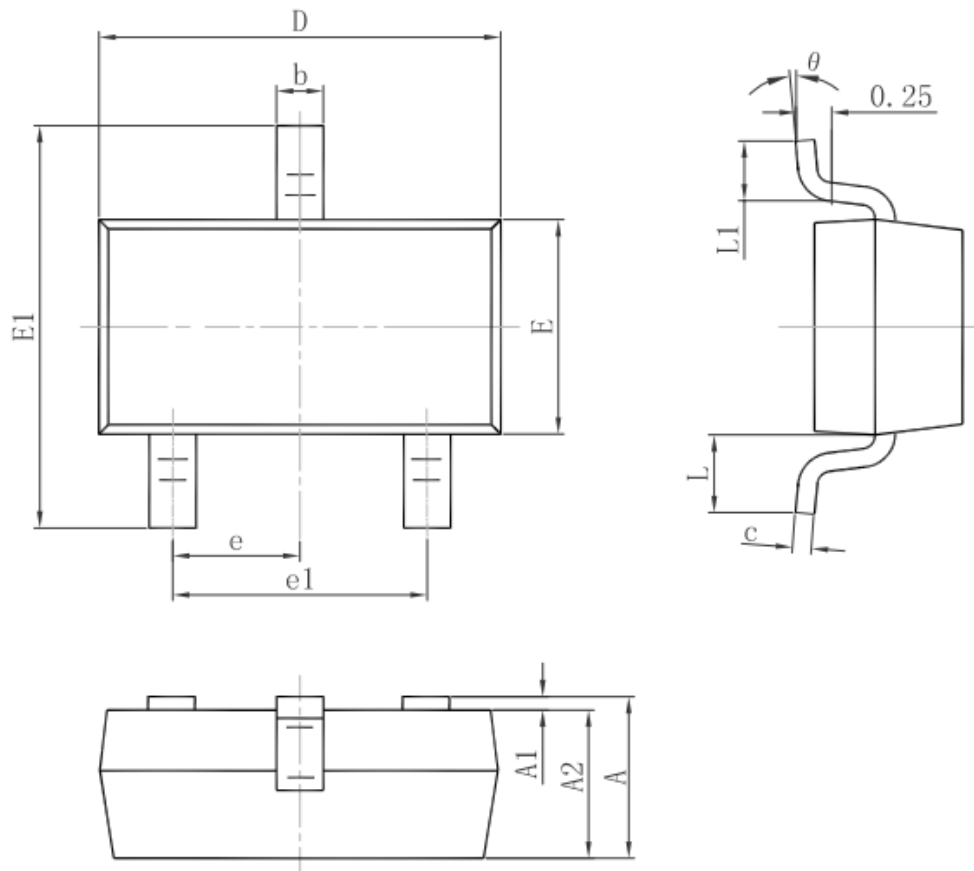

Symbol	Dimensions In Millimeters		Dimensions In Inches	
	Min.	Max.	Min.	Max.
A	0.900	1.150	0.035	0.045
A1	0.000	0.100	0.000	0.004
A2	0.900	1.050	0.035	0.041
b	0.300	0.500	0.012	0.020
c	0.080	0.150	0.003	0.006
D	2.800	3.000	0.110	0.118
E	1.200	1.400	0.047	0.055
E1	2.250	2.550	0.089	0.100
e	0.950 TYP.		0.037 TYP.	
e1	1.800	2.000	0.071	0.079
L	0.550 REF.		0.022 REF.	
L1	0.300	0.500	0.012	0.020
θ	0°	8°	0°	8°

3-pin SOT23-3 Outline Dimensions

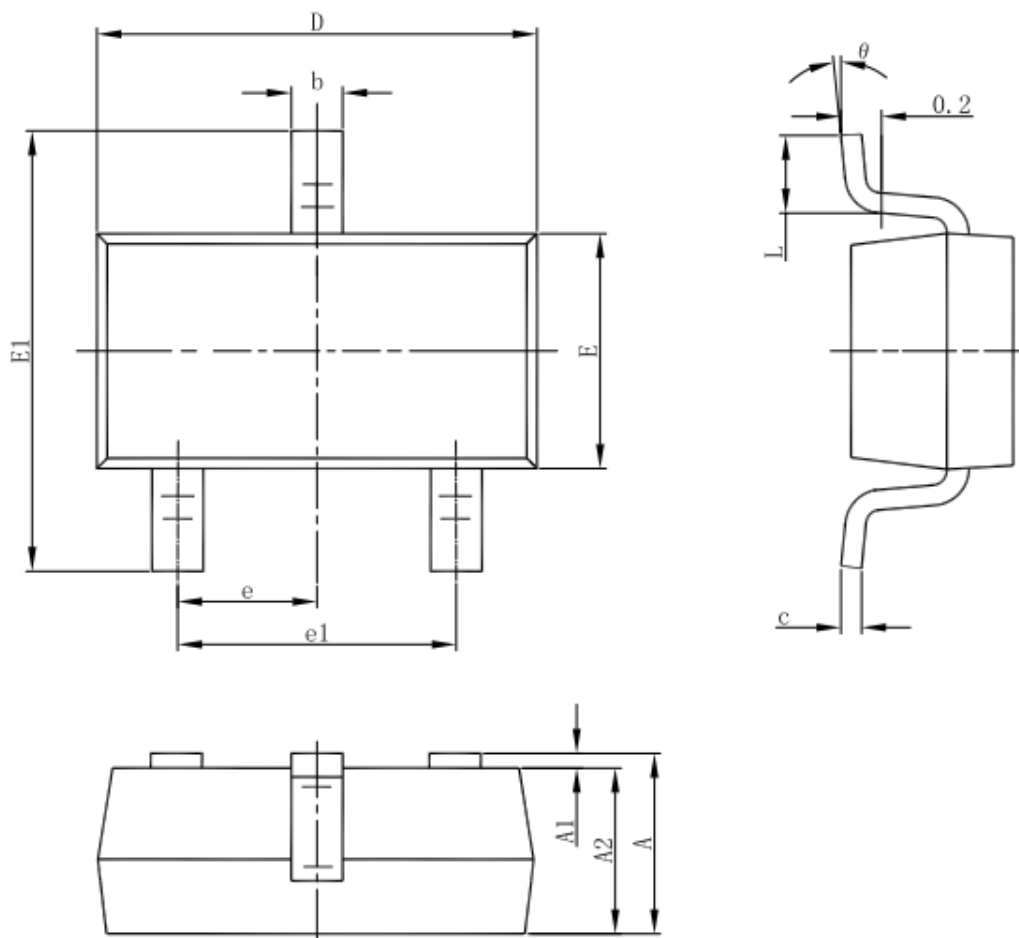

Symbol	Dimensions In Millimeters		Dimensions In Inches	
	Min	Max	Min	Max
A	1.050	1.250	0.041	0.049
A1	0.000	0.100	0.000	0.004
A2	1.050	1.150	0.041	0.045
b	0.300	0.500	0.012	0.020
c	0.100	0.200	0.004	0.008
D	2.820	3.020	0.111	0.119
E	1.500	1.700	0.059	0.067
E1	2.650	2.950	0.104	0.116
e	0.950(BSC)		0.037(BSC)	
e1	1.800	2.000	0.071	0.079
L	0.300	0.600	0.012	0.024
θ	0°	8°	0°	8°

5-pin SOT23-5L Outline Dimensions

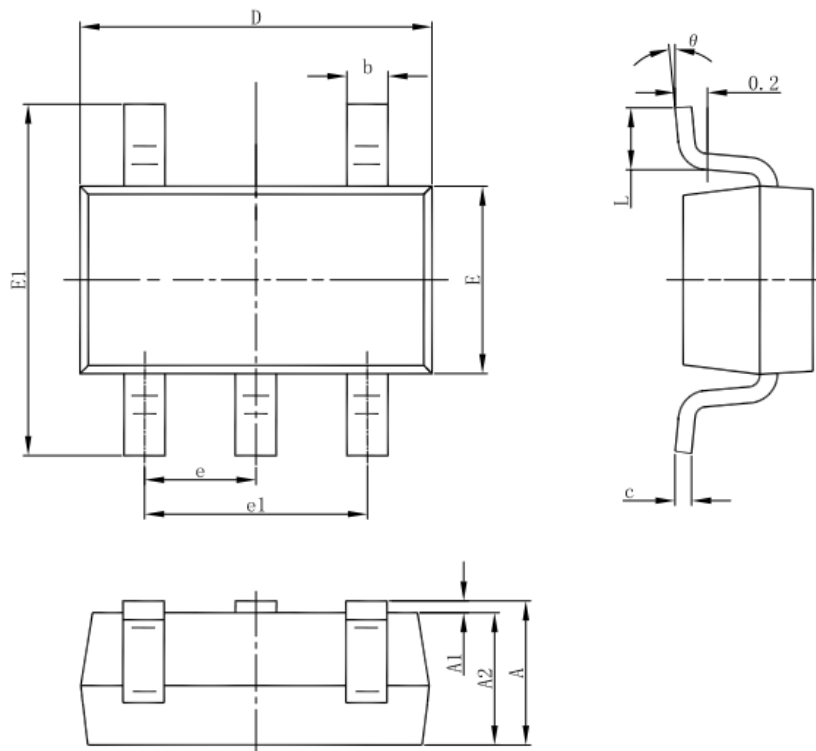

Symbol	Dimensions In Millimeters		Dimensions In Inches	
	Min	Max	Min	Max
A	1.050	1.250	0.041	0.049
A1	0.000	0.100	0.000	0.004
A2	1.050	1.150	0.041	0.045
b	0.300	0.500	0.012	0.020
c	0.100	0.200	0.004	0.008
D	2.820	3.020	0.111	0.119
E	1.500	1.700	0.059	0.067
E1	2.650	2.950	0.104	0.116
e	0.950(BSC)		0.037(BSC)	
e1	1.800	2.000	0.071	0.079
L	0.300	0.600	0.012	0.024
θ	0°	8°	0°	8°

3-pin SOT89-3 Outline Dimensions

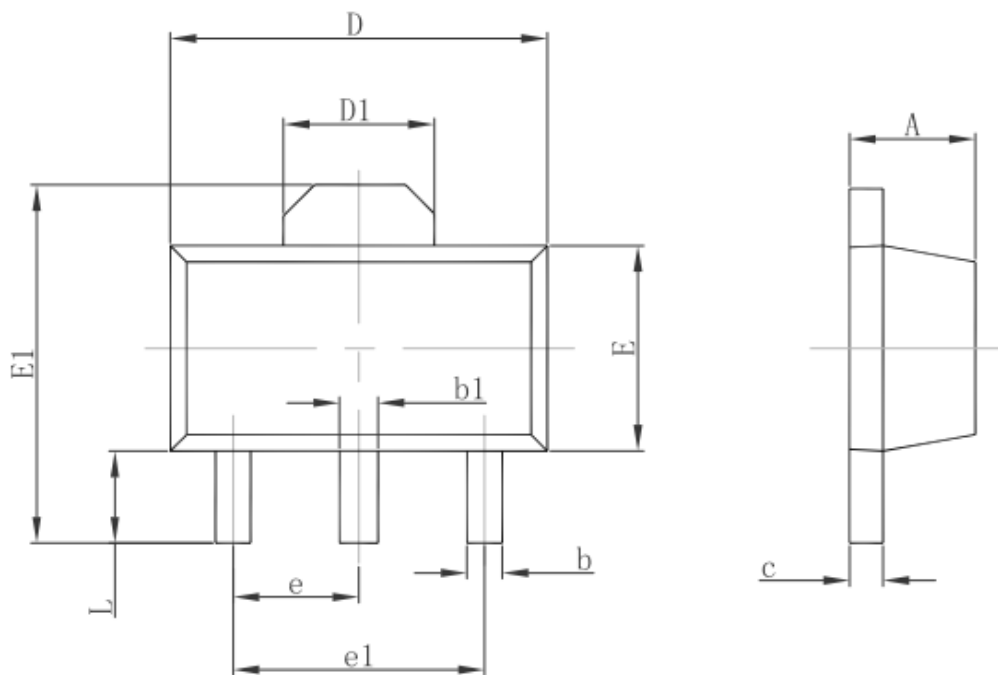

Symbol	Dimensions In Millimeters		Dimensions In Inches	
	Min.	Max.	Min.	Max.
A	1.400	1.600	0.055	0.063
b	0.320	0.520	0.013	0.020
b1	0.400	0.580	0.016	0.023
c	0.350	0.440	0.014	0.017
D	4.400	4.600	0.173	0.181
D1	1.550 REF.		0.061 REF.	
E	2.300	2.600	0.091	0.102
E1	3.940	4.250	0.155	0.167
e	1.500 TYP.		0.060 TYP.	
e1	3.000 TYP.		0.118 TYP.	
L	0.900	1.200	0.035	0.047

3-pin TO92 Outline Dimensions

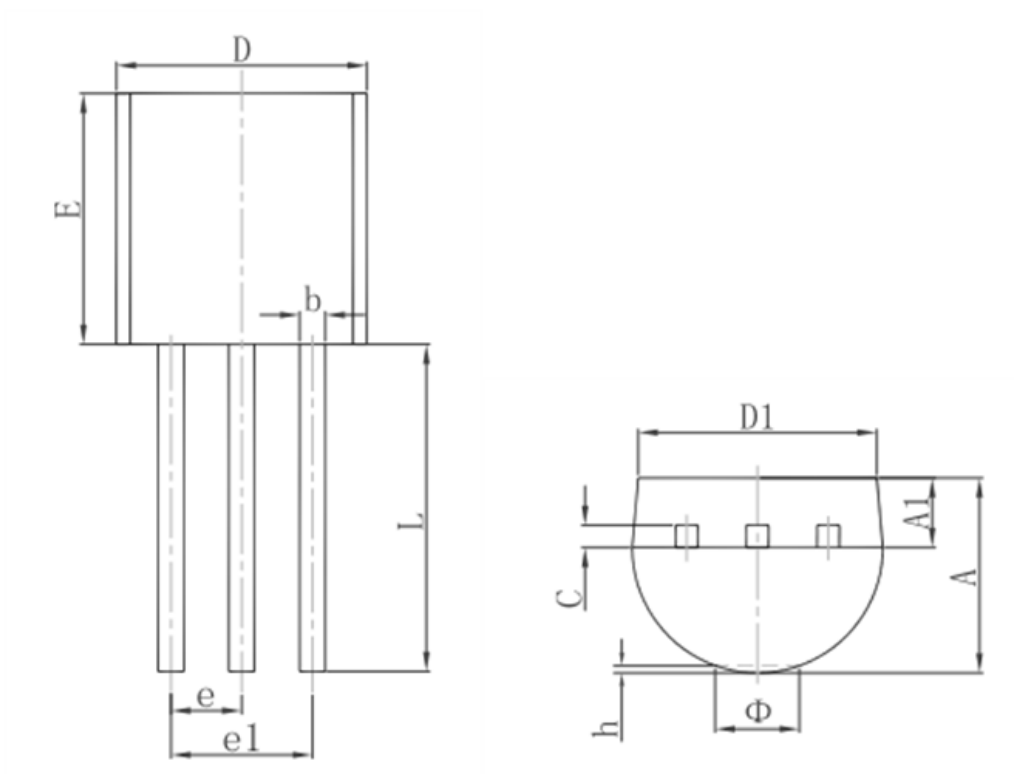

Symbol	Dimensions In Millimeters		Dimensions In Inches	
	Min.	Max.	Min.	Max.
A	3.300	3.700	0.130	0.146
A1	1.100	1.400	0.043	0.055
b	0.380	0.550	0.015	0.022
c	0.360	0.510	0.014	0.020
D	4.300	4.700	0.169	0.185
D1	3.430		0.135	
E	4.300	4.700	0.169	0.185
e	1.270 TYP.		0.050 TYP.	
e1	2.440	2.640	0.096	0.104
L	14.100	14.500	0.555	0.571
Φ		1.600		0.063
h	0.000	0.380	0.000	0.015

X-ON Electronics

Largest Supplier of Electrical and Electronic Components

Click to view similar products for [Switching Controllers](#) category:

Click to view products by [Suntek](#) manufacturer:

Other Similar products are found below :

[NCP1218AD65R2G](#) [NCP1234AD100R2G](#) [NCP1244BD065R2G](#) [NCP1336ADR2G](#) [NCP6153MNTWG](#) [NCP81101BMNTXG](#)
[NCP81205MNTXG](#) [SJE6600](#) [AZ7500BMTR-E1](#) [IR35215MTRPBF](#) [SG3845DM](#) [NCP4204MNTXG](#) [NCP6132AMNR2G](#)
[NCP81102MNTXG](#) [NCP81203MNTXG](#) [NCP81206MNTXG](#) [NX2155HCUPTR](#) [UBA2051C](#) [IR35201MTRPBF](#) [FSL4110LRLX](#)
[NCP1015ST65T3G](#) [NCP1240AD065R2G](#) [NCP1240FD065R2G](#) [NCP1336BDR2G](#) [NCP1361BABAYSNT1G](#) [NCP1230P100G](#)
[NX2124CSTR](#) [SG2845M](#) [NCP1366BABAYDR2G](#) [NCP81101MNTXG](#) [TEA19362T/1J](#) [NCP81174NMNTXG](#) [NCP4308DMTTWG](#)
[NCP4308DMNTWG](#) [NCP4308AMTTWG](#) [NCP1366AABAYDR2G](#) [NCP1256ASN65T1G](#) [NCP1251FSN65T1G](#) [NCP1246BLD065R2G](#)
[MB39A136PFT-G-BND-ERE1](#) [NCP1256BSN100T1G](#) [LV5768V-A-TLM-E](#) [NCP1365BABCYDR2G](#) [NCP1365AABCYDR2G](#)
[IR35204MTRPBF](#) [MCP1633T-E/MG](#) [MCP1633-E/MG](#) [NCV1397ADR2G](#) [NCP81599MNTXG](#) [NCP1246ALD065R2G](#)