

SK6215 16V, 500mA, Low Power Consumption LDO

GENERAL DESCRIPTION

The SK6215 series is a set of three-terminal, lowpower, high voltage regulators implemented inCMOS technology. The series features extremely low quiescent current which is typically 2.0 μ A.They allow input voltages as high as 16V. The device provides large current with a significantly small dropout voltage.

The SK6215 consists of a high-precision voltage reference, an error correction circuit, an over temperature protection circuit, and a current limited output driver. They are available with several fixed output voltages ranging from 2.5V to 5.0V.CMOS technology ensures low dropout voltage and low current consumption. Although designed primarily as fixed voltage regulators, these devices can be used with external components to generate variable voltages and currents.

The SK6215 regulators are available in standard SOT89-3L and SOT23-3L packages. Standard products are Pb-free and Halogen-free.

FEATURES

- Input voltage: 3V~16V
- Output range: 2.5V~5.0V
- Output current: 500mA (Within Max Power Dissipation)
- Dropout voltage: 200mV @ $V_{OUT}=3.3V, I_{OUT}=100mA$
- Quiescent current: 2 μ A Typ.
- Good line regulation: 0.01%
- Good load regulation: 5mV@1mA $\leq I_o \leq 50mA$
- Low temperature coefficient: 0.07mV/ $^{\circ}C$

APPLICATIONS

- Battery powered equipment
- Voltage regulator for microprocessor
- Voltage regulator for LAN cards
- Wireless communication equipment
- Audio/Video equipment

TYPICAL APPLICATION CIRCUIT

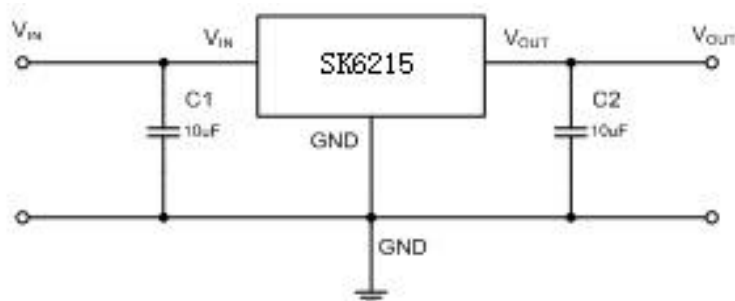

PIN ASSIGNMENT



SK6215T3B

SOT89-3L

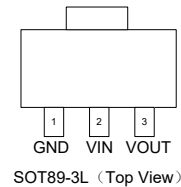

SK6215S3

SOT23-3L

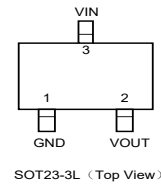

ORDERING INFORMATION

PART NO	PACAKGE	TEMPERATURE	TAPE & REEL
SK6215S3-XX	SOT23-3L	-40 ~ +85 °C	3000/REEL
SK6215T3B-XX	SOT89-3L	-40 ~ +85 °C	1000/REEL

"XX": several fixed output voltages ranging from 2.5V to 5.0V

PART NUMBER RULES

SK6215 [1]-[2]

Code	Description
[1]	Package: S3: SOT23-3L T3B: SOT89-3L(Btypepin-out)
[2]	Voltage version: XX: several fixed output voltages ranging from 2.5V to 5.0V Example: 33: 3.3V

MARKING DESCRIPTION:

SOT23-3L:

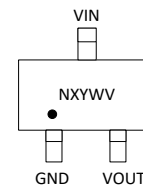

"N": product code, here use "T" stands for "SK6215".

"X": Package factory

"Y": Wafer foundry vendor.

"W": The week of manufacturing. "A" stands for week 1,

"Z" stands for week 26, "a" stands for week 27, "z" stands for week 52.

"V": Product version code.

SOT89-3L:

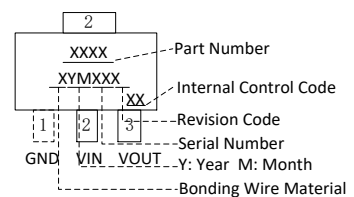

PIN DESCRIPTION

PIN NO		SYMBOL	I/O	DESCRIPTION
SK6215T3B	SK6215S3			
1	1	GND	Ground	Ground
2	3	VIN	Power	Input
3	2	VOUT	O	Output

ABSOLUTE MAXIMUM RATINGS^(Note)

SYMBOL	ITEMS	VALUE	UNIT
V _{IN}	Input Voltage	-0.3~20	V
V _{OUT}	Output Voltage	-0.3~V _{IN}	V
P _{DMAX}	Power Dissipation	OTPLimited	W
T _J	Junction Temperature	-40~125	°C
T _{STG}	Storage Temperature	-55 to 150	°C
T _{SOLDER}	Package Lead Soldering Temperature	260°C, 10s	

Note: Exceed these limits to damage to the device. Exposure to absolute maximum rating conditions may affect device reliability.

RECOMMENDED OPERATING RANGE

SYMBOL	ITEMS	VALUE	UNIT
V _{IN}	VIN Supply Voltage	3 to 16	V
R _{θJA}	Thermal Resistance on PCB	75	°C/W
T _{OPT}	Operating Temperature	-40 to +85	°C

ELECTRICAL CHARACTERISTICS

The following specifications apply for $V_{OUT}=3.3V$, $T_A=25^{\circ}C$, unless specified otherwise.

SYMBOL	ITEMS	CONDITIONS	MIN	TYP	MAX	UNIT
V_{IN}	Input Voltage		3	5	16	V
V_{OUT}	V_{OUT} Range	$V_{IN} = V_{OUT} + 2V$, $I_{OUT}=1mA$	$V_{OUT} * 0.98$	V_{OUT}	$V_{OUT} * 1.02$	V
I_{OUT}	Output Current	Within Maximum Power Dissipation		500		mA
I_Q	Quiescent Current	No Load		2		μA
V_{DROP}	Dropout Voltage	$V_{OUT}=3.3V$, $I_{OUT}=100mA$, $\Delta V=2\%$		200		mV
		$V_{OUT}=5.0V$, $I_{OUT}=100mA$, $\Delta V=2\%$		115		
ΔV_{LINE}	Line Regulation	$V_{IN} = 4 \sim 14V$, $I_{OUT}=1mA$		0.01	0.07	%/V
ΔV_{LOAD}	Load Regulation	$V_{IN} = V_{OUT} + 2V$, $I_{OUT}=1 \sim 50mA$		5		mV
I_{SHORT}	Short Current	V_{OUT} Short to GND with 3Ω		90		mA
$\Delta V_{OUT}/\Delta T_a$	Temperature coefficient	$I_{OUT}=1mA$, $0 \leq T_a \leq 70^{\circ}C$		0.07	0.2	mV/ $^{\circ}C$
T_{SD}	Thermal Shutdown Protectio	$V_{IN} = V_{OUT} + 2V$, $I_{OUT} = 1mA$		160		$^{\circ}C$

SIMPLIFIED BLOCK DIAGRAM

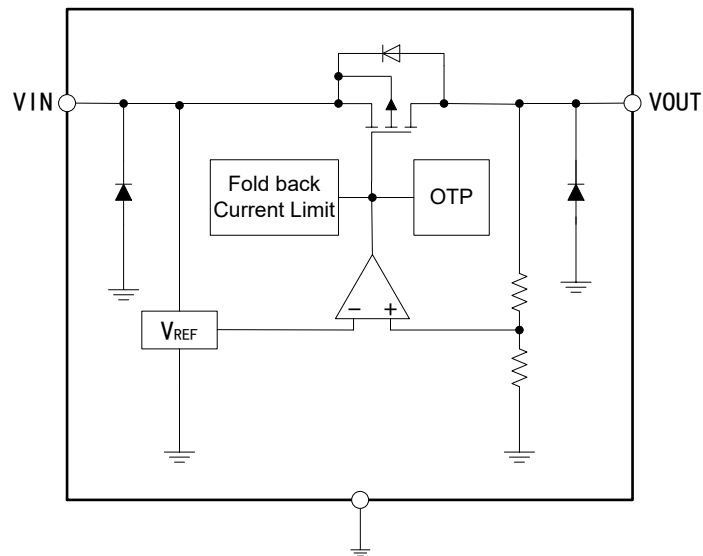

TYPICAL PERFORMANCE CHARACTERISTICS

$C_{IN}=10\mu F$, $C_{OUT}=10\mu F$, $T_{OPT}=25^{\circ}C$, $V_{IN}=5.3V$, $V_{OUT}=3.3V$, unless specified otherwise.

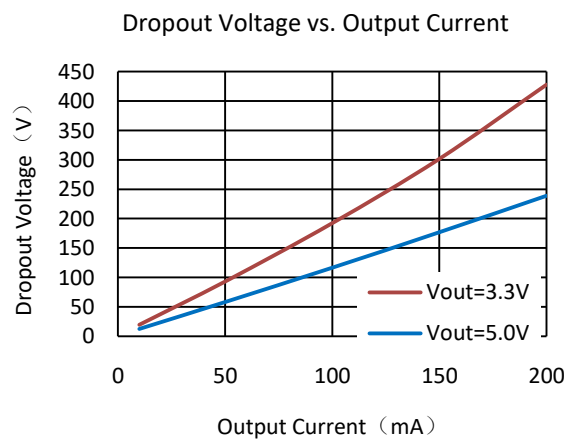
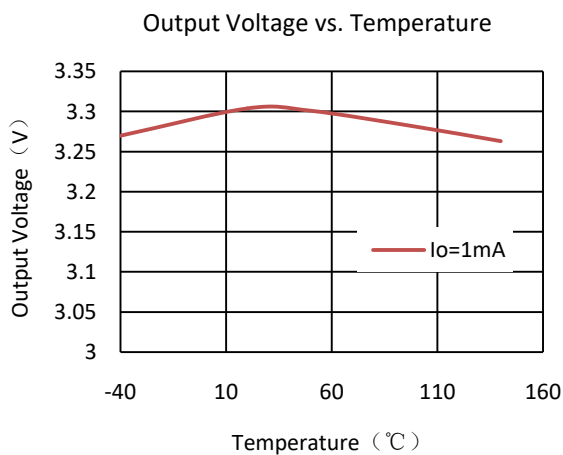
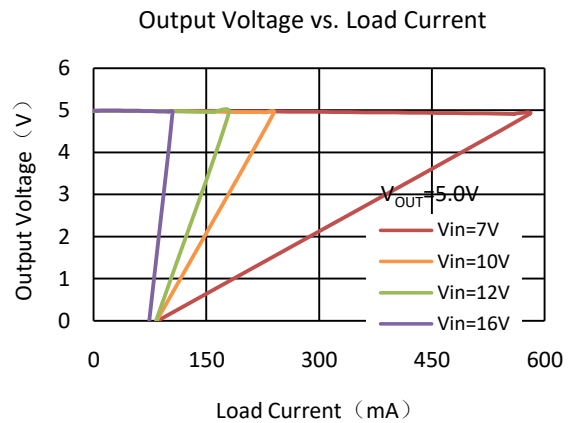
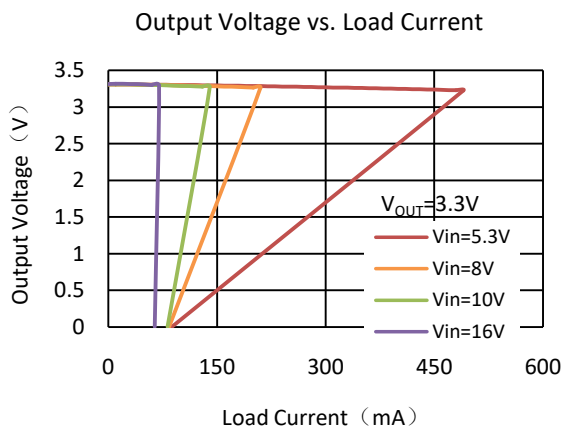
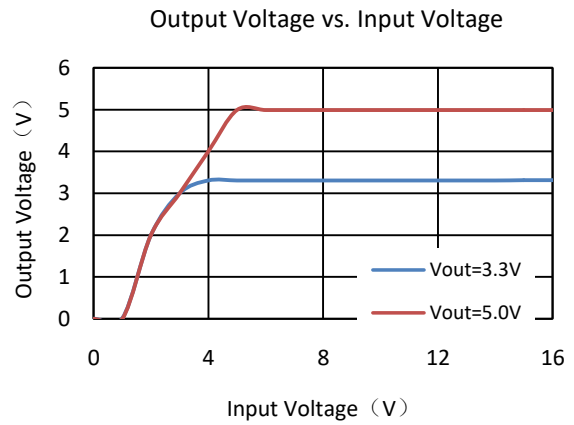
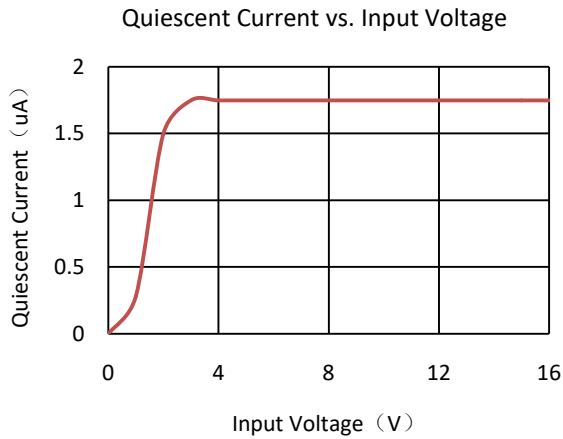

Power ON

CH1: V_{IN} CH2: V_{OUT}

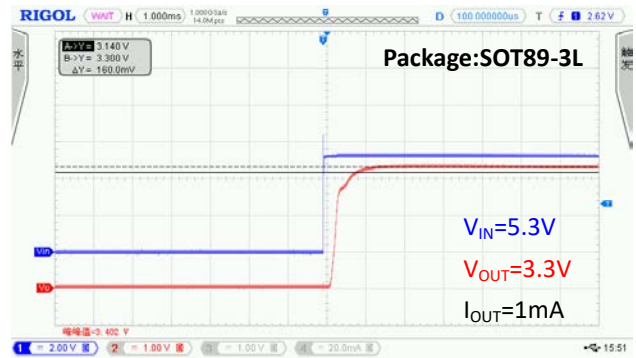
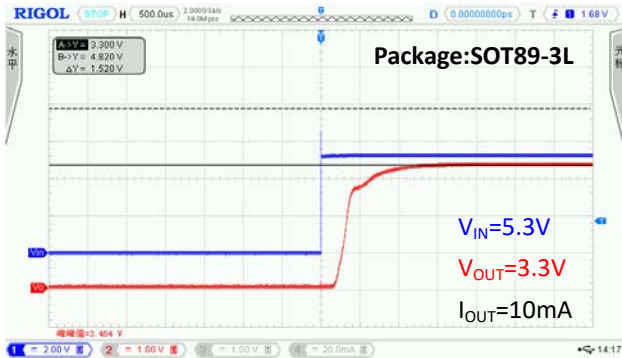

Line Transient

CH1: V_{IN} CH2: V_{OUT}

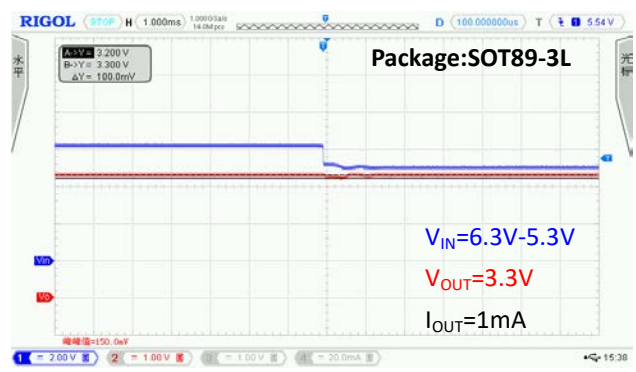
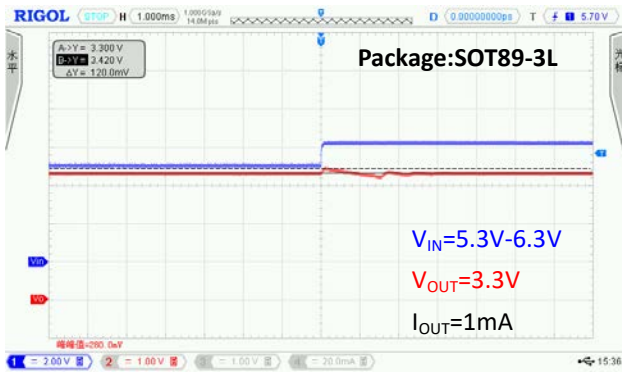
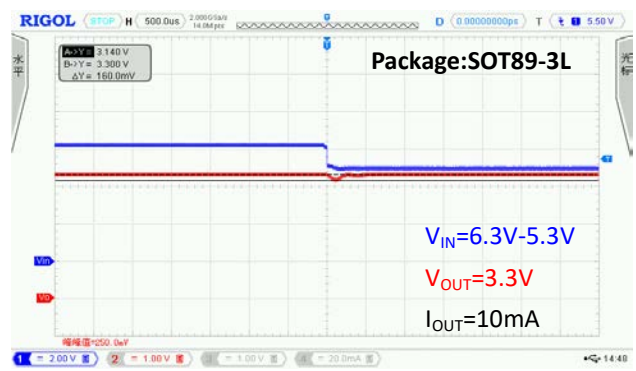
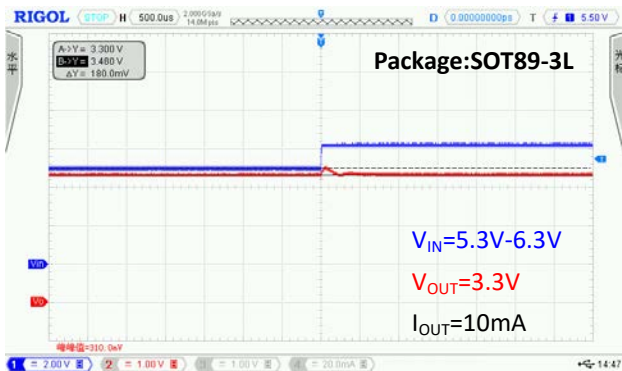

Load Transient

CH1: V_{IN} CH2: V_{OUT} CH4: I_{OUT}

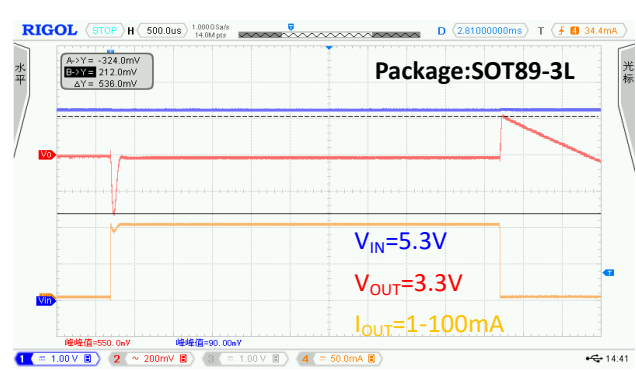
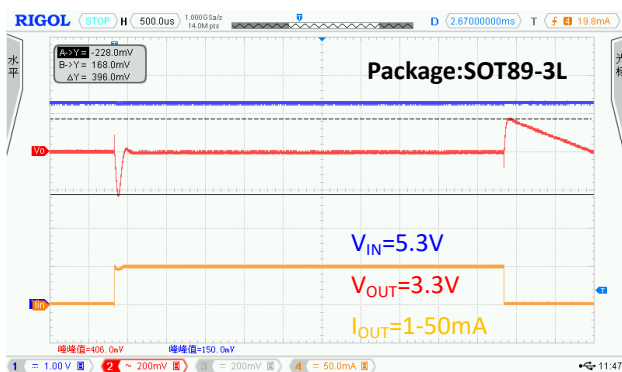

PACKAGE OUTLINE

Package	SOT23-3L	Devices per reel	3000Pcs	Unit	mm
---------	----------	------------------	---------	------	----

Package Dimension:

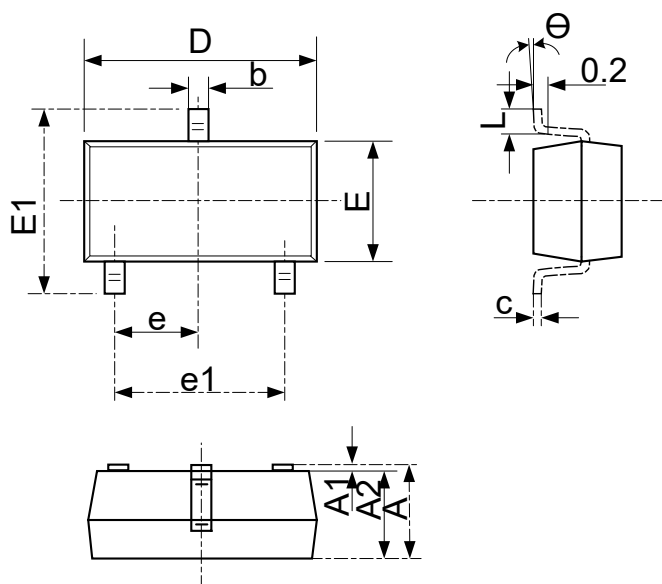

Symbol	Dimensions In Millimeters		Dimensions In Inches	
	Min	Max	Min	Max
A	1.050	1.250	0.041	0.049
A1	0.000	0.100	0.000	0.004
A2	1.050	1.150	0.041	0.045
b	0.300	0.500	0.012	0.020
c	0.100	0.200	0.004	0.008
D	2.820	3.020	0.111	0.119
E	1.500	1.700	0.059	0.067
E1	2.650	2.950	0.104	0.116
e	0.950(BSC)		0.037(BSC)	
e1	1.800	2.000	0.071	0.079
L	0.300	0.600	0.012	0.024
θ	0°	8°	0°	8°

PACKAGE OUTLINE

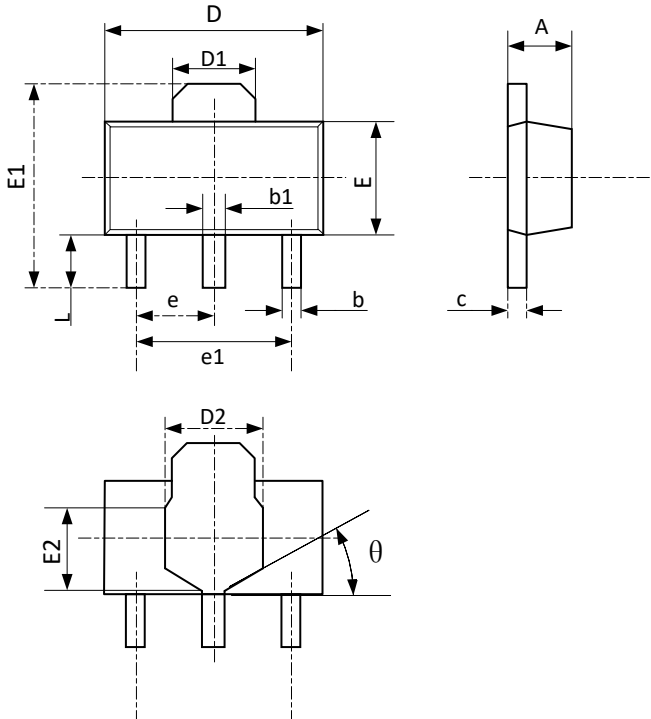
Package	SOT89-3L	Devices per reel	1000Pcs	Unit	mm
Package Dimension:					
					
Symbol	Dimensions In Millimeters		Dimensions In Inches		
	Min	Max	Min	Max	
A	1.400	1.600	0.055	0.063	
b	0.320	0.520	0.013	0.020	
b1	0.400	0.580	0.016	0.023	
c	0.350	0.440	0.014	0.017	
D	4.400	4.600	0.173	0.181	
D1	1.550 REF		0.061 REF		
D2	1.750 REF		0.069 REF		
E	2.300	2.600	0.091	0.102	
E1	3.940	4.250	0.155	0.167	
E2	1.900 REF		0.075 REF		
e	1.500 TYP		0.060 TYP		
e1	3.000 TYP		0.118 TYP		
L	0.900	1.200	0.035	0.047	
θ	45°		45°		

X-ON Electronics

Largest Supplier of Electrical and Electronic Components

Click to view similar products for [Linear Voltage Regulators](#) category:

Click to view products by [Suntek](#) manufacturer:

Other Similar products are found below :

[LV56831P-E](#) [LV5684PVD-XH](#) [MCDTSA6-2R](#) [L7815ACV-DG](#) [PQ3DZ53U](#) [LV56801P-E](#) [TLE42794G](#) [L78L05CZ/1SX](#) [L78LR05DL-MA-E](#) [636416C](#) [714954EB](#) [BA033LBSG2-TR](#) [LV5680P-E](#) [L78M15CV-DG](#) [L79M05T-E](#) [TLS202A1MBVHTSA1](#) [L78LR05D-MA-E](#) [NCV317MBTG](#) [NTE7227](#) [LV5680NPVC-XH](#) [LT1054CN8](#) [MP2018GZD-5-Z](#) [MP2018GZD-33-Z](#) [MIC5281-3.3YMM](#) [MC78L06BP-AP](#) [TA48LS05F\(TE85L,F\)](#) [TA78L12F\(TE12L,F\)](#) [TC47BR5003ECT](#) [TCR2LN12,LF\(S](#) [TCR2LN28,LF\(S](#) [TCR2LN30,LF\(S](#) [TCR3DF295,LM\(CT](#) [TCR3DF40,LM\(CT](#) [BA178M20CP-E2](#) [L78M12ABDT](#) [LM7812SX/NOPB](#) [LR645N3-G-P003](#) [LR645N3-G-P013](#) [ZXTR2005P5-13](#) [SCD7812BTG](#) [TCR3DF335,LM\(CT](#) [ZXTR2012K-13](#) [TLE42994E V33](#) [ZXTR2008K-13](#) [ZXTR2005K-13](#) [L88R05DL-E](#) [ADP3300ARTZ-2.7RL7](#) [LM120K-15/883](#) [IFX54441LDVXUMA1](#) [LM317D2T-TR](#)