

SK6512S

High Voltage, Low Power LDO

DESCRIPTION

The SK6512S is a high voltage, low power consumption and high performance LDO. The family uses an advanced CMOS process and a PMOSFET pass device to achieve fast start-up, with high output voltage accuracy. The SK6512S is stable with a 1.0 μ F ~ 10 μ F ceramic output capacitor, and uses a precision voltage reference and feedback loop to achieve a worst-case accuracy of 2% over all load, line, process, and temperature variations.

FEATURES

- Wide Input Voltage Range: up to 36 V
- Output Current: 200 mA
- Standard Fixed Output Voltage Options: 1.8 V, 2.5 V, 3.0 V, 3.3 V, 3.6 V, and 5.0 V
- Other Output Voltage Options Available on Request
- Low IQ: 1.5 μ A
- Low Dropout Voltage
- Short current protection: 100 mA
- Excellent Load / Line Transient Response
- Line Regulation: 0.01 %/V typical
- Package: DFN1 \times 1-4, SOT23-3, SOT23-5, SOT89-3

ORDER INFORMATION

Model	Package	Ordering Number	Packing Option
SK6512S	DFN1 \times 1-4	SK6512SD4-XX	Tape and Reel, 10000
	SOT23-3	SK6512SS3-XX	Tape and Reel, 3000
	SOT23-5	SK6512SS5-XX	Tape and Reel, 3000
	SOT89-3 (L-Type)	SK6512ST3A-XX	Tape and Reel, 1000
	SOT89-3	SK6512ST3B-XX	Tape and Reel, 1000

*XX: When expressed as 18, the output voltage is 1.8 V; when expressed as 30 the output voltage is 3.0 V.

PIN CONFIGURATION(TOP VIEW)

SK6512SD4-XX

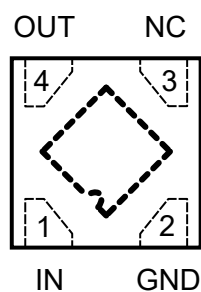

DFN1×1-4

SK6512SS3-XX

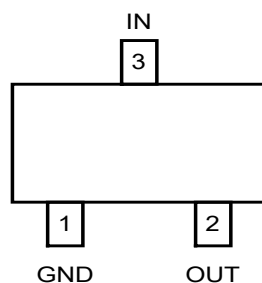

SOT23-3

SK6512SS5-XX

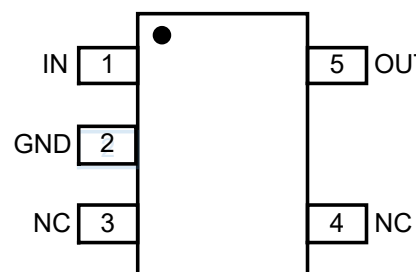

SOT23-5

SK6512ST3A-XX

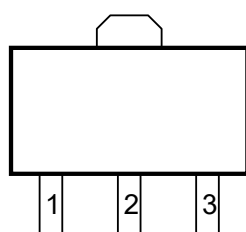

OUT GND IN
SOT89-3(L-Type)

SK6512ST3B-XX

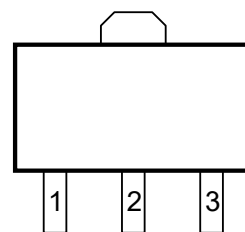

GND IN OUT
SOT89-3

PIN DESCRIPTIONS

Pin					Symbol	Description
DFN1×1-4	SOT23-3	SOT23-5	SOT89-3 (L-Type)	SOT89-3		
1	3	1	3	2	IN	Supply input pin. Must be closely decoupled to GND with a 1 μ F or greater ceramic capacitor.
2	1	2	2	1	GND	Ground.
3		3, 4			NC	No connection.
4	2	5	1	3	OUT	Output pin. Bypass a 1 μ F or greater ceramic capacitor from this pin to ground.

BLOCK DIAGRAM

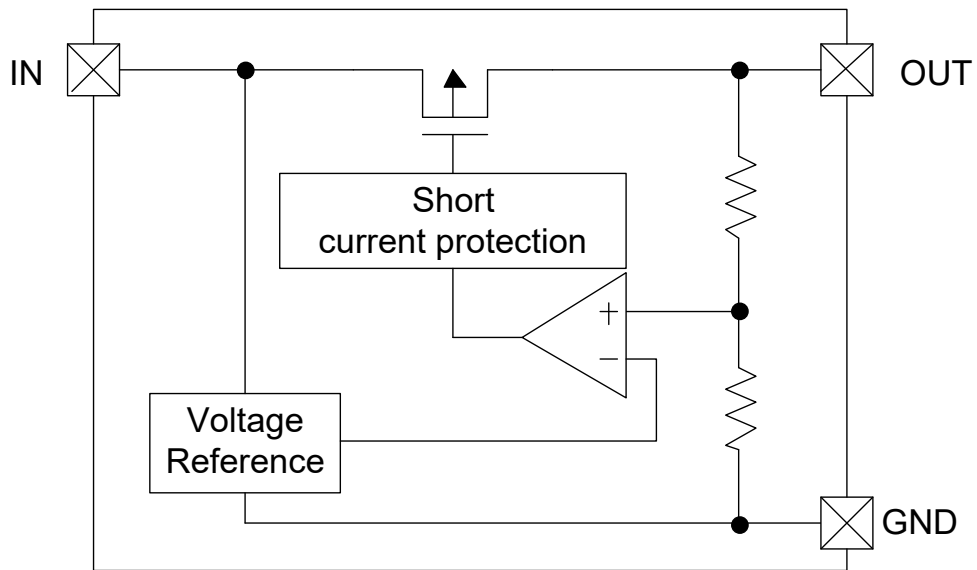

FUNCTIONAL DESCRIPTION

Input Capacitor

A 1 μF – 10 μF ceramic capacitor is recommended to connect between V_{IN} and GND pins to decouple input power supply glitch and noise. The amount of the capacitance may be increased without limit. This input capacitor must be located as close as possible to the device to assure input stability and less noise. For PCB layout, a wide copper trace is required for both V_{IN} and GND.

Output Capacitor

An output capacitor is required for the stability of the LDO. The recommended output capacitance is from 1 μF to 10 μF , Equivalent Series Resistance (ESR) is from 5 $\text{m}\Omega$ to 100 $\text{m}\Omega$, and temperature characteristics are X7R or X5R. Higher capacitance values help to improve load/line transient response. The output capacitance may be increased to keep low undershoot / overshoot. Place output capacitor as close as possible to OUT and GND pins.

Low Quiescent Current

The SK6512S, consuming only 1.5 μA for all input range or output loading, provides great power saving in portable and low power applications.

Short Current Limit Protection

When output current at the OUT pin is higher than current limit threshold or the OUT pin is short-circuit to GND, the short current limit protection will be triggered and clamp the output current to approximately 100 mA to prevent over-current and to protect the regulator from damage due to overheating.

ABSOLUTE MAXIMUM RATINGS

Parameter	Rating		Unit
IN pin to GND pin	-0.3 to 40		V
OUT pin to GND pin	-0.3 to 6		V
Thermal Resistance (Junction to Ambient)	SOT23-3	360	$^{\circ}\text{C}/\text{W}$
	SOT23-5	250	
	DFN1 \times 1-4	180	
	SOT89-3	135	
Operating Junction Temperature	-40 to 125		$^{\circ}\text{C}$
Storage Temperature	-65 to 150		$^{\circ}\text{C}$
Lead Temperature (Soldering, 10 sec)	300		$^{\circ}\text{C}$
ESD (HBM mode)	ESDA/JEDEC JS-001-2017		$\pm 2000\text{V}$

ELECTRICAL CHARACTERISTICS

$V_{IN} = V_{OUT} + 2\text{ V}$, $T_A = 25^\circ$, $C_{IN} = 10\ \mu\text{f}$, $C_{OUT} = 10\ \mu\text{f}$ unless otherwise noted.

Parameter	Symbol	Test Conditions	Min	Typ	Max	Unit
Input Voltage Operation Range	V_{IN}				36	V
Dropout Voltage	V_{DROP}	$V_{OUT} = 5\text{ V}$, $I_{OUT} = 150\text{ mA}$		720		mV
		$V_{OUT} = 5\text{ V}$, $I_{OUT} = 100\text{ mA}$		420		
		$V_{OUT} = 3.3\text{ V}$, $I_{OUT} = 150\text{ mA}$		820		
		$V_{OUT} = 3.3\text{ V}$, $I_{OUT} = 100\text{ mA}$		520		
DC Supply Quiescent Current	I_Q			1.5	3	μA
Regulated Output Voltage	V_{OUT}	$I_{OUT} = 1\text{ mA}$	$V_{OUT} \times 0.98$		$V_{OUT} \times 1.02$	V
Output Voltage Line Regulation	Reg_{LINE}	$V_{IN} = V_{OUT} + 1\text{ V}$ to 30 V , $I_{OUT} = 10\text{ mA}$ ($\Delta V_{OUT} / \Delta V_{IN} / V_{OUT}$)		0.01	0.04	%/V
Output Voltage Load Regulation	Reg_{LOAD}	I_{OUT} from 1 mA to 150 mA $V_{IN} = V_{OUT} + 2\text{ V}$		5	20	mV
		I_{OUT} from 1 mA to 150 mA $V_{IN} = 10\text{ V}$		25	60	mV
Maximum Output Current	I_{OUT}	$V_{IN} = V_{OUT} + 1\text{ V}$	200			mA
Short Current Protection	I_{SHORT}	OUT short to GND		100		mA
Output Noise	e_N	10 Hz to 100 kHz, $I_{OUT} = 30\text{ mA}$		90		μV_{RMS}

TYPICAL PERFORMANCE CHARACTERISTICS

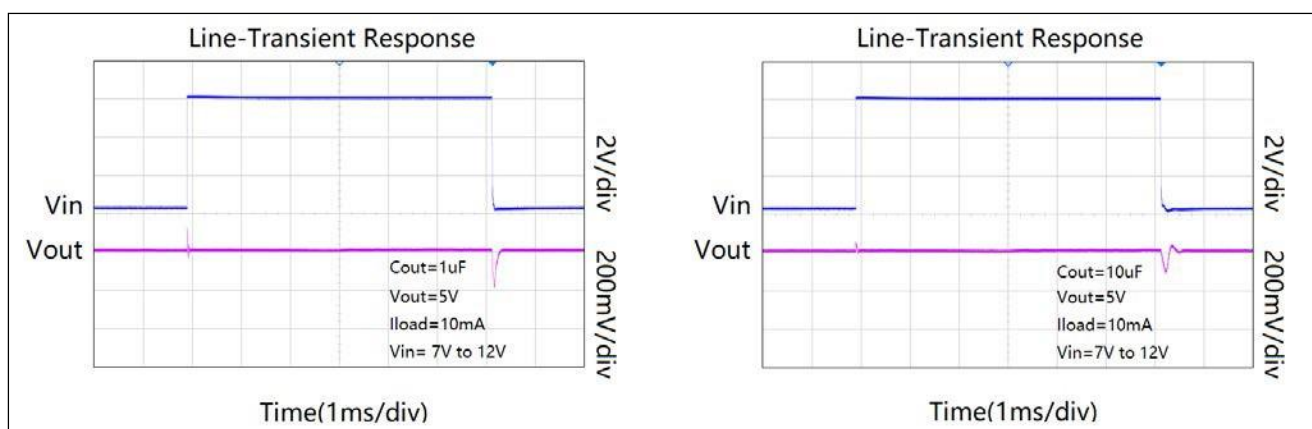

Fig1. Line-Transient Response

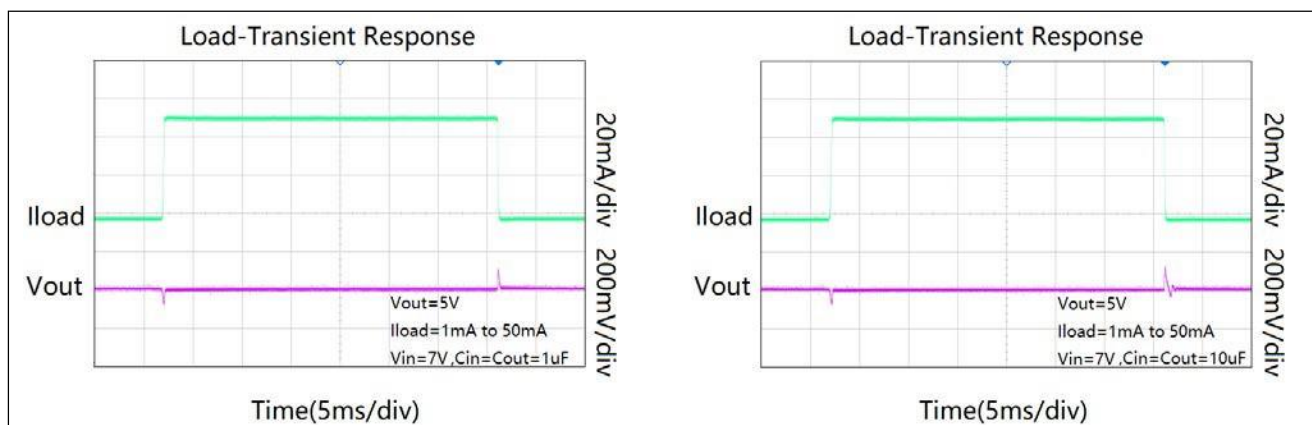

Fig2. Load-Transient Response

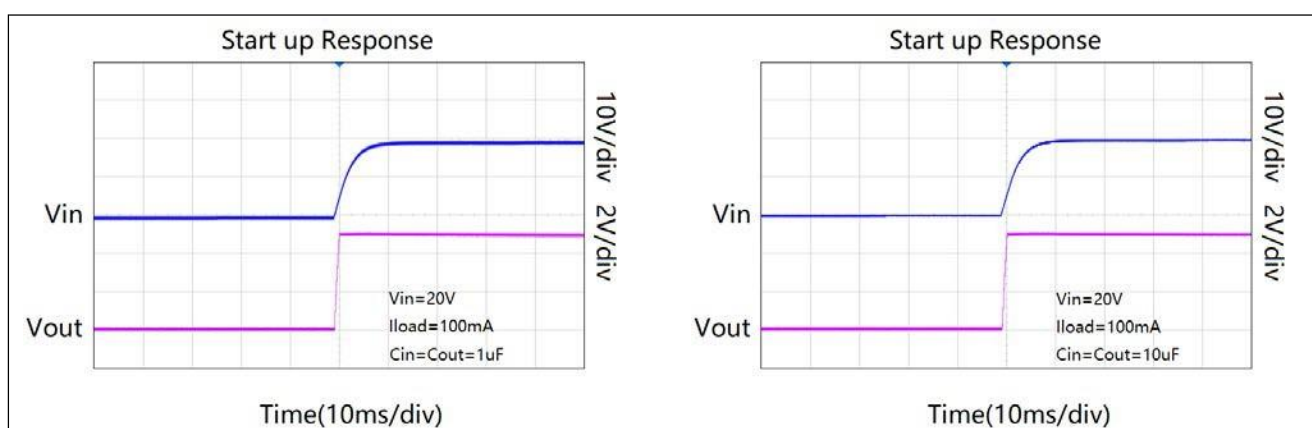

Fig3. Start up Response

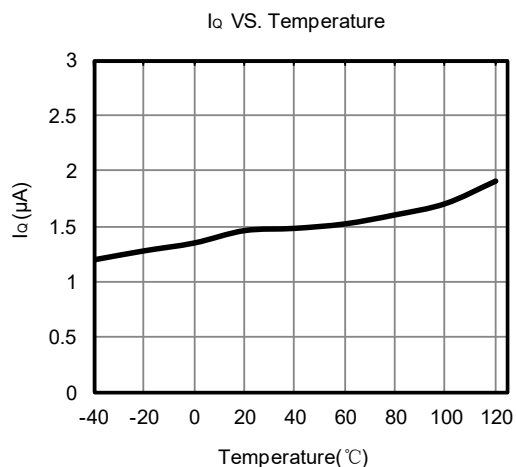
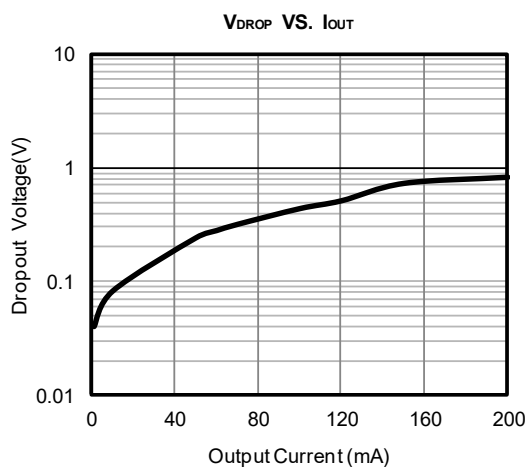
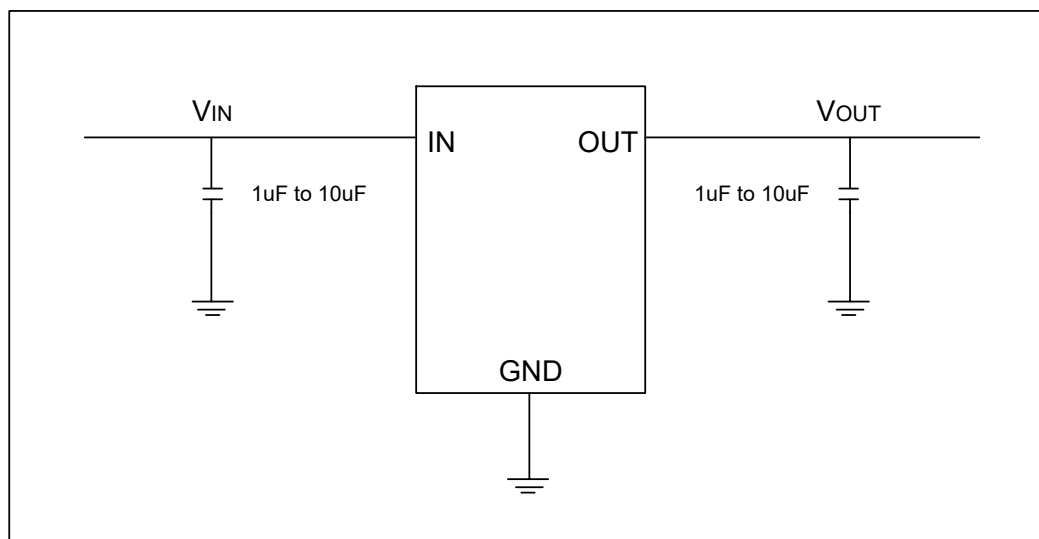

Fig4. Dropout Voltage VS Output Current

Fig5. DC Supply Quiescent Current VS Temperature

APPLICATION CIRCUITS



PACKAGE OUTLINE

DFN1×1-4

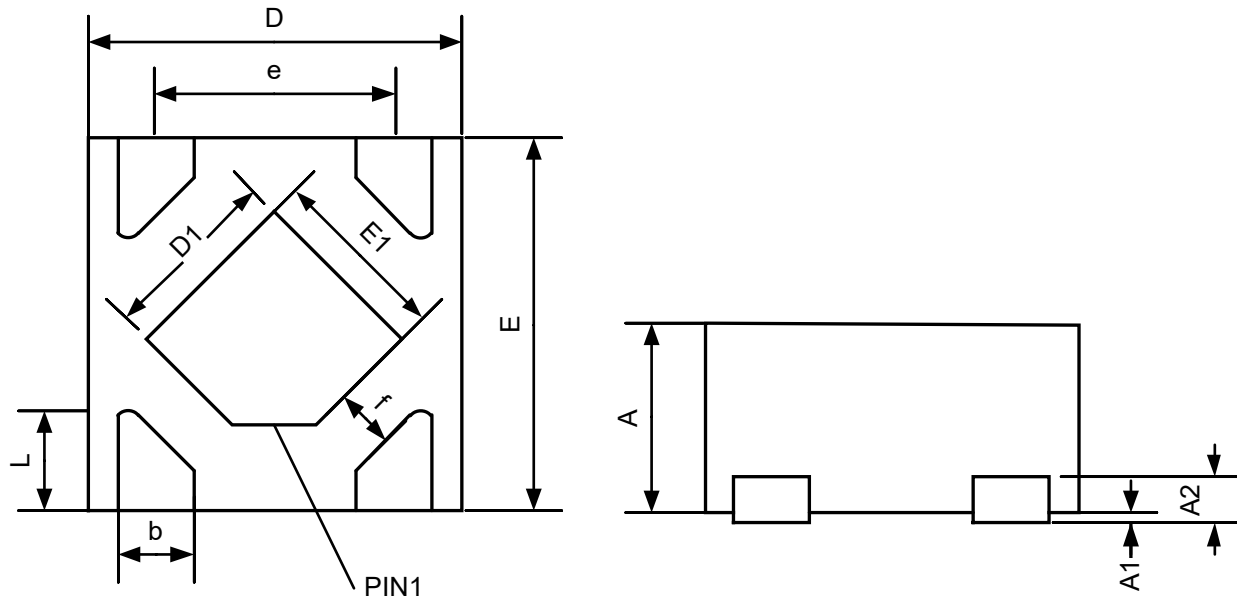

Symbol	Dimensions In Millimeters	
	Min	Max
A	0.45	0.55
A1	0.00	0.05
A2	0.125REF	
b	0.15	0.25
D	0.95	1.05
D1	0.38	0.58
E	0.95	1.05
E1	0.38	0.58
e	0.65BSC	
L	0.15	0.35

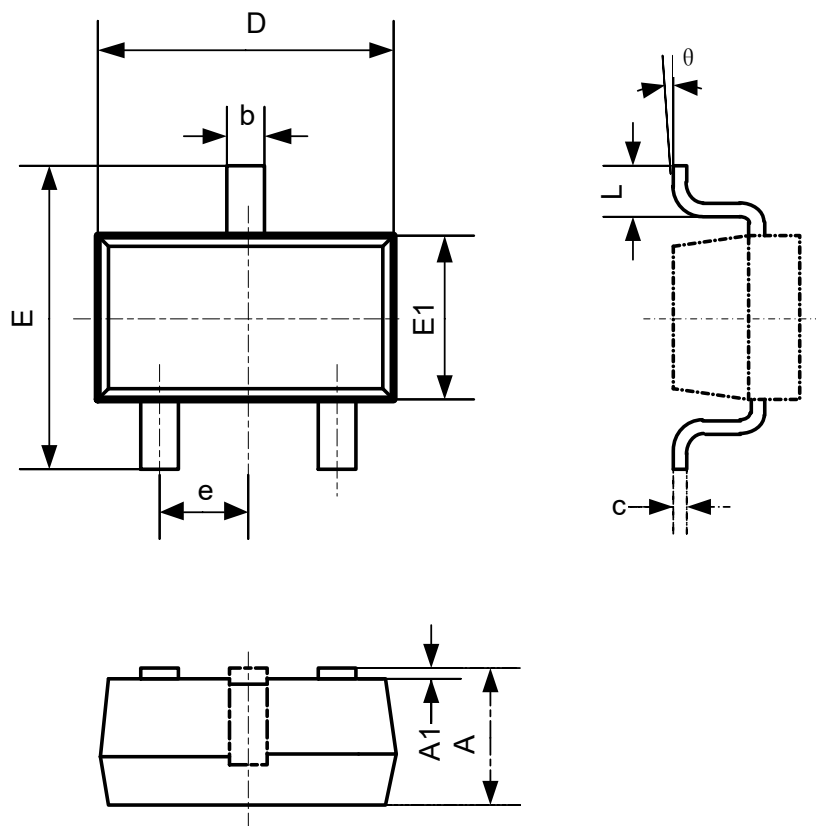
SOT23-3

Symbol	Dimensions In Millimeters	
	Min	Max
A	1.05	1.25
A1	0.00	0.10
b	0.30	0.40
c	0.10	0.20
D	2.82	3.02
E	2.60	3.00
E1	1.50	1.70
e	0.95BSC	
L	0.30	0.60
θ	0°	8°

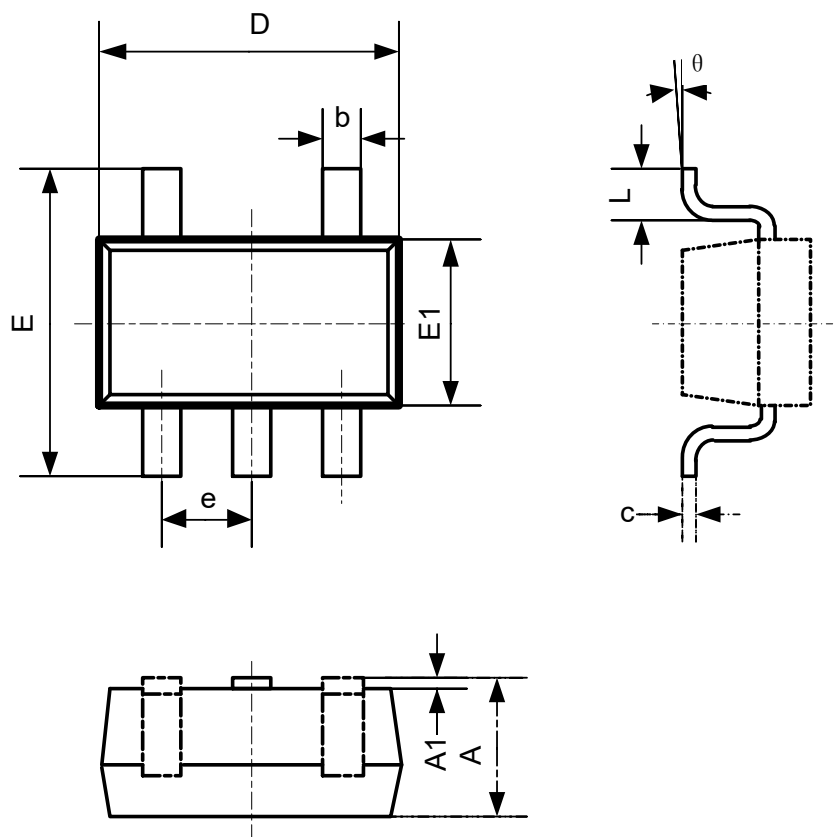
SOT23-5

Symbol	Dimensions In Millimeters	
	Min	Max
A	1.05	1.25
A1	0.00	0.10
b	0.35	0.50
c	0.08	0.20
D	2.82	3.02
E	2.60	3.00
E1	1.60	1.70
e	0.95BSC	
L	0.30	0.60
θ	0°	8°

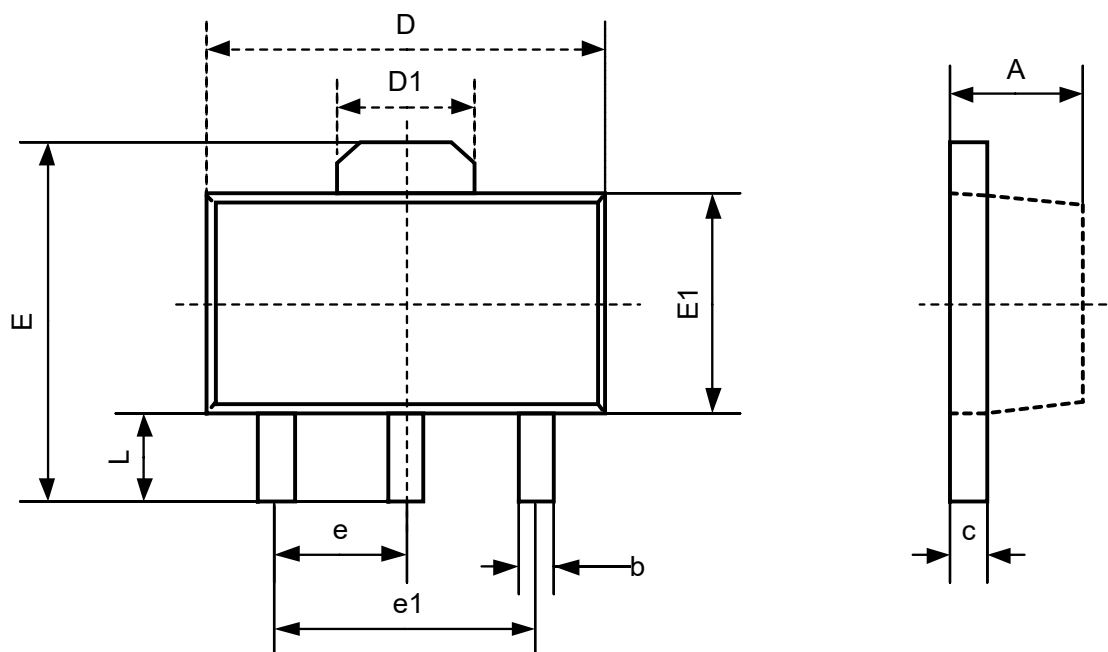
SOT89-3

Symbol	Dimensions In Millimeters	
	Min	Max
A	1.40	1.60
b	0.32	0.52
c	0.35	0.44
D	4.40	4.60
D1	1.55BSC	
E	3.94	4.25
E1	2.30	2.60
e	1.50BSC	
e1	3.00BSC	
L	0.90	1.20
θ	0°	8°

X-ON Electronics

Largest Supplier of Electrical and Electronic Components

Click to view similar products for [Linear Voltage Regulators](#) category:

Click to view products by [Suntek](#) manufacturer:

Other Similar products are found below :

[LV56831P-E](#) [LV5684PVD-XH](#) [MCDTSA6-2R](#) [L7815ACV-DG](#) [PQ3DZ53U](#) [LV56801P-E](#) [TLE42794G](#) [L78L05CZ/1SX](#) [L78LR05DL-MA-E](#) [636416C](#) [714954EB](#) [BA033LBSG2-TR](#) [LV5680P-E](#) [L78M15CV-DG](#) [L79M05T-E](#) [TLS202A1MBVHTSA1](#) [L78LR05D-MA-E](#) [NCV317MBTG](#) [NTE7227](#) [LV5680NPVC-XH](#) [LT1054CN8](#) [MP2018GZD-5-Z](#) [MP2018GZD-33-Z](#) [MIC5281-3.3YMM](#) [MC78L06BP-AP](#) [TA48LS05F\(TE85L,F\)](#) [TA78L12F\(TE12L,F\)](#) [TC47BR5003ECT](#) [TCR2LN12,LF\(S](#) [TCR2LN28,LF\(S](#) [TCR2LN30,LF\(S](#) [TCR3DF295,LM\(CT](#) [TCR3DF40,LM\(CT](#) [BA178M20CP-E2](#) [L78M12ABDT](#) [LM7812SX/NOPB](#) [LR645N3-G-P003](#) [LR645N3-G-P013](#) [ZXTR2005P5-13](#) [SCD7812BTG](#) [TCR3DF335,LM\(CT](#) [ZXTR2012K-13](#) [TLE42994E V33](#) [ZXTR2008K-13](#) [ZXTR2005K-13](#) [L88R05DL-E](#) [ADP3300ARTZ-2.7RL7](#) [LM120K-15/883](#) [IFX54441LDVXUMA1](#) [LM317D2T-TR](#)