

SK6513C 200mA Low Power LDO

General Description

The SK6513C series is a set of three-terminal low power high voltage regulators implemented in CMOS technology. They allow input voltages as high as 37V. They are available with several fixed output voltages ranging from 3.0V to 5.0V. CMOS technology ensures low voltage drop and low quiescent current. Although designed primarily as fixed voltage regulators, these devices can be used with external components to obtain variable voltages and currents.

Features

- Low power consumption
- Low voltage drop
- Low temperature coefficient
- High input voltage (up to 37V)
- Output voltage accuracy: tolerance $\pm 2\%$
- SOT23-3 and SOT89 package

Applications

- Battery-powered equipment
- Communication equipment
- Audio/Video equipment

Application Circuits

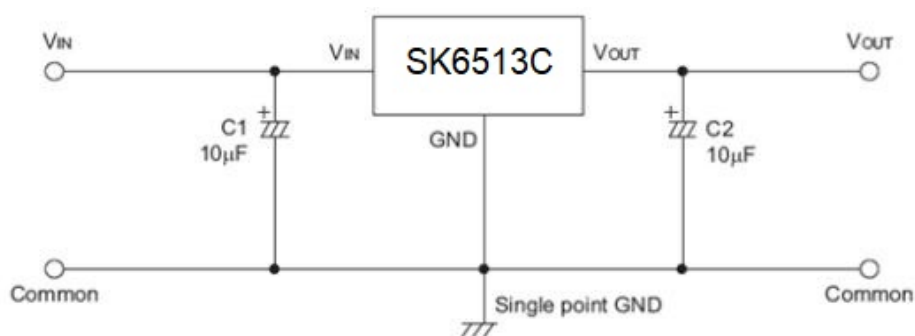

Pin Assignment

SOT89 (Top view)

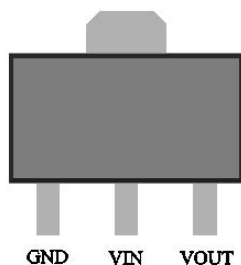

SOT23-3 (Top view)

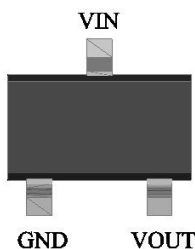

Absolute Maximum Ratings

Supply Voltage-0.3V to 37V

Storage Temperature-50°C to 125°C

Operating Temperature-40°C to 85°C

Note: These are stress ratings only. Stresses exceeding the range specified under “Absolute Maximum

Ratings” may cause substantial damage to the device. Functional operation of this device at other conditions beyond those listed in the specification is not implied and prolonged exposure to extreme conditions may affect device reliability.

Thermal Information

Symbol	Parameter	Package	Max.	Unit
θ_{JA}	Thermal Resistance (Junction to Ambient) (Assume no ambient airflow, no heat sink)	SOT23	500	°C/W
		SOT89	200	°C/W
P_D	Power Dissipation	SOT23	0.20	W
		SOT89	0.50	W

Note: P_D is measured at $T_a = 25^\circ\text{C}$

Block Diagram

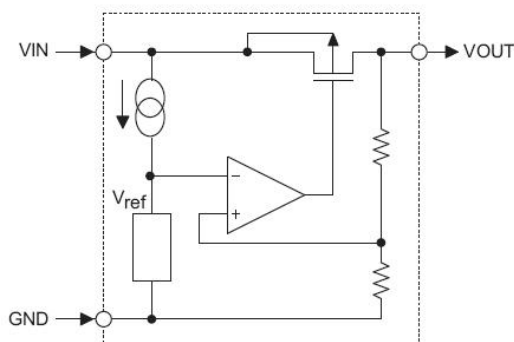

Ordering Information

Order Number	Package	Temperature	RoHS	Marking	Shipping Type
SK6513CMR-30	SOT23-3	-40°C to +85°C	YES	30H	3000PCS/REEL
SK6513CMR-33	SOT23-3	-40°C to +85°C	YES	33H	3000PCS/REEL
SK6513CMR-36	SOT23-3	-40°C to +85°C	YES	36H	3000PCS/REEL
SK6513CMR-44	SOT23-3	-40°C to +85°C	YES	44H	3000PCS/REEL
SK6513CMR-50	SOT23-3	-40°C to +85°C	YES	50H	3000PCS/REEL
SK6513CPR-30	SOT89	-40°C to +85°C	YES	7530H#	1000PCS/REEL
SK6513CPR-33	SOT89	-40°C to +85°C	YES	7533H#	1000PCS/REEL
SK6513CPR-36	SOT89	-40°C to +85°C	YES	7536H#	1000PCS/REEL
SK6513CPR-44	SOT89	-40°C to +85°C	YES	7544H#	1000PCS/REEL
SK6513CPR-50	SOT89	-40°C to +85°C	YES	7550H#	1000PCS/REEL

Electrical Characteristics

SK6513C-30 (3.0V Output Type)

Symbol	Parameter	Test Conditions		Min.	Typ.	Max.	Unit
		V _{IN}	Conditions				
V _{OUT}	Output Voltage	8V	I _{OUT} =10mA	2.94	3.00	3.06	V
I _{OUT}	Output Current	6V	-	-	200	-	mA
ΔV _{OUT}	Load Regulation	8V	1mA ≤ I _{OUT} ≤ 20mA	-	40	60	mV
V _{DIF}	Voltage Drop(Note)	-	I _{OUT} =1mA, ΔV _{OUT} =2%	-	10	-	mV
ISS	Current Consumption	8V	No load	-	2.0	5.0	μA
$\frac{\Delta V_{OUT}}{\Delta V_{IN} \times V_{OUT}}$	Line Regulation	-	4V ≤ V _{IN} ≤ 37V I _{OUT} =1mA	-	0.3	-	%/V
V _{IN}	Input Voltage	-	-	-	-	35	V
$\frac{\Delta V_{OUT}}{\Delta T_a}$	Temperature Coefficient	8V	I _{OUT} =10mA 0°C < T _a < 100°C	-	±0.12	-	mV/°C

Note: Dropout voltage is defined as the input voltage minus the output voltage that produces a 2% change in the output voltage from the value at V_{IN} = V_{OUT}+2V with a fixed load.

SK6513C-33 (3.3V Output Type)

Symbol	Parameter	Test Conditions		Min.	Typ.	Max.	Unit
		V _{IN}	Conditions				
V _{OUT}	Output Voltage	8V	I _{OUT} =10mA	3.234	3.300	3.366	V
I _{OUT}	Output Current	6.3V	-	-	200	-	mA
ΔV _{OUT}	Load Regulation	8V	1mA ≤ I _{OUT} ≤ 20mA	-	40	60	mV
V _{DIF}	Voltage Drop(Note)	-	I _{OUT} =1mA, ΔV _{OUT} =2%	-	10	-	mV
ISS	Current Consumption	8V	No load	-	2.0	5.0	μA
$\frac{\Delta V_{OUT}}{\Delta V_{IN} \times V_{OUT}}$	Line Regulation	-	4.5V ≤ V _{IN} ≤ 37V I _{OUT} =1mA	-	0.3	-	%/V
V _{IN}	Input Voltage	-	-	-	-	35	V
$\frac{\Delta V_{OUT}}{\Delta T_a}$	Temperature Coefficient	8V	I _{OUT} =10mA 0°C < T _a < 100°C	-	±0.12	-	mV/°C

Note: Dropout voltage is defined as the input voltage minus the output voltage that produces a 2% change in the output voltage from the value at V_{IN} = V_{OUT}+2V with a fixed load.

SK6513C-36 (3.6V Output Type)

Symbol	Parameter	Test Conditions		Min.	Typ.	Max.	Unit
		V _{IN}	Conditions				
V _{OUT}	Output Voltage	8V	I _{OUT} =10mA	3.528	3.600	3.672	V
I _{OUT}	Output Current	6.6V	-	-	200	-	mA
ΔV _{OUT}	Load Regulation	8V	1mA≤I _{OUT} ≤20mA	-	40	60	mV
V _{DIF}	Voltage Drop(Note)	-	I _{OUT} =1mA, ΔV _{OUT} =2%	-	10	-	mV
ISS	Current Consumption	8V	No load	-	2.0	5.0	μA
$\frac{\Delta V_{OUT}}{\Delta V_{IN} \times V_{OUT}}$	Line Regulation	-	4.6V≤V _{IN} ≤37V I _{OUT} =1mA	-	0.3	-	%/V
V _{IN}	Input Voltage	-	-	-	-	35	V
$\frac{\Delta V_{OUT}}{\Delta T_a}$	Temperature Coefficient	8V	I _{OUT} =10mA 0°C<T _a <100°C	-	±0.12	-	mV/°C

Note: Dropout voltage is defined as the input voltage minus the output voltage that produces a 2% change in the output voltage from the value at V_{IN} = V_{OUT}+2V with a fixed load.

SK6513C-44 (4.4V Output Type)

Symbol	Parameter	Test Conditions		Min.	Typ.	Max.	Unit
		V _{IN}	Conditions				
V _{OUT}	Output Voltage	8V	I _{OUT} =10mA	4.312	4.400	4.488	V
I _{OUT}	Output Current	7.4V	-	-	200	-	mA
ΔV _{OUT}	Load Regulation	8V	1mA≤I _{OUT} ≤20mA	-	40	60	mV
V _{DIF}	Voltage Drop(Note)	-	I _{OUT} =1mA, ΔV _{OUT} =2%	-	10	-	mV
ISS	Current Consumption	8V	No load	-	2.0	5.0	μA
$\frac{\Delta V_{OUT}}{\Delta V_{IN} \times V_{OUT}}$	Line Regulation	-	5.4V≤V _{IN} ≤38V I _{OUT} =1mA	-	0.3	-	%/V
V _{IN}	Input Voltage	-	-	-	-	36	V
$\frac{\Delta V_{OUT}}{\Delta T_a}$	Temperature Coefficient	8V	I _{OUT} =10mA 0°C<T _a <100°C	-	±0.12	-	mV/°C

Note: Dropout voltage is defined as the input voltage minus the output voltage that produces a 2% change in the output voltage from the value at V_{IN} = V_{OUT}+2V with a fixed load.

SK6513C-50 (5.0V Output Type)

Symbol	Parameter	Test Conditions		Min.	Typ.	Max.	Unit
		V _{IN}	Conditions				
V _{OUT}	Output Voltage	8V	I _{OUT} =10mA	4.90	5.00	5.10	V
I _{OUT}	Output Current	8V	-	-	200	-	mA
ΔV _{OUT}	Load Regulation	8V	1mA ≤ I _{OUT} ≤ 20mA	-	40	60	mV
V _{DIF}	Voltage Drop(Note)	-	I _{OUT} =1mA, ΔV _{OUT} =2%	-	10	-	mV
I _{SS}	Current Consumption	8V	No load	-	2.0	5.0	μA
$\frac{\Delta V_{OUT}}{\Delta V_{IN} \times V_{OUT}}$	Line Regulation	-	6V ≤ V _{IN} ≤ 39V I _{OUT} =1mA	-	0.3	-	%/V
V _{IN}	Input Voltage	-	-	-	-	36	V
$\frac{\Delta V_{OUT}}{\Delta T_a}$	Temperature Coefficient	8V	I _{OUT} =10mA 0°C < T _a < 100°C	-	±0.12	-	mV/°C

Note: Dropout voltage is defined as the input voltage minus the output voltage that produces a 2% change in the output voltage from the value at V_{IN} = V_{OUT}+2V with a fixed load.

Package Information

3-pin SOT23-3 Outline Dimensions

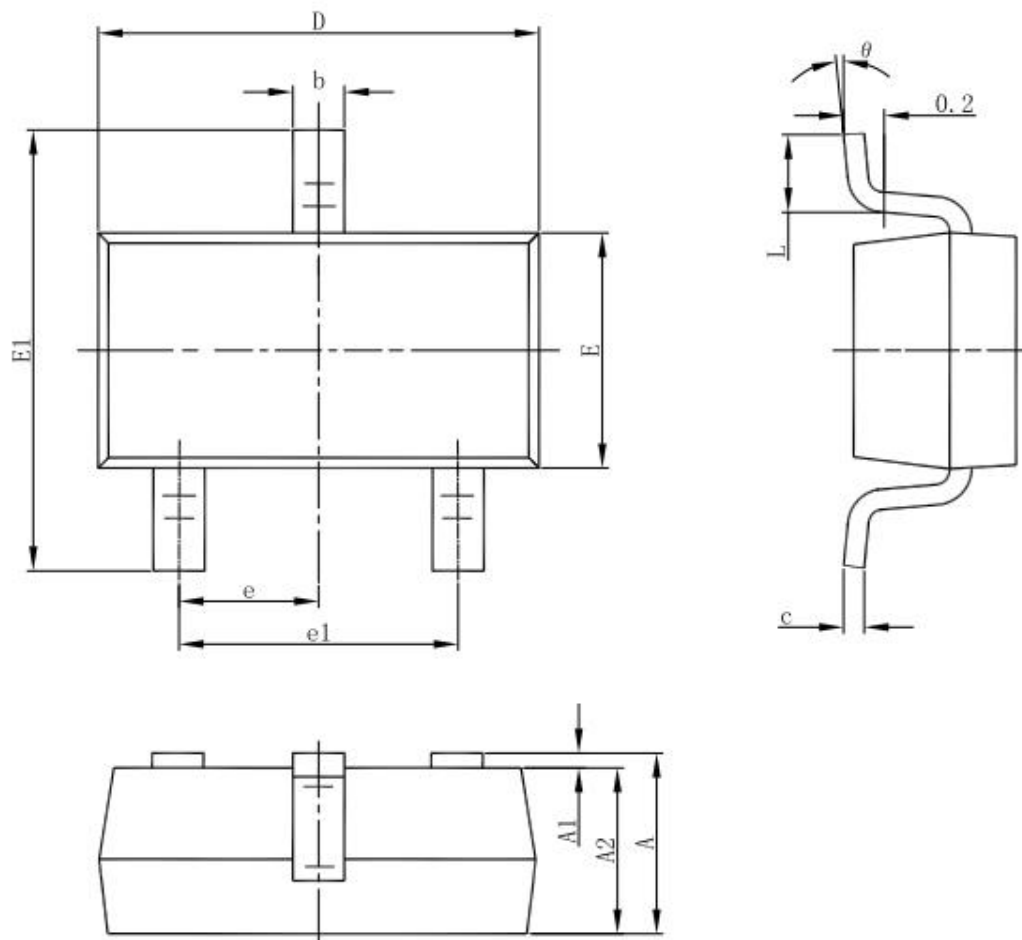

Symbol	Dimensions In Millimeters		Dimensions In Inches	
	Min	Max	Min	Max
A	1.050	1.250	0.041	0.049
A1	0.000	0.100	0.000	0.004
A2	1.050	1.150	0.041	0.045
b	0.300	0.500	0.012	0.020
c	0.100	0.200	0.004	0.008
D	2.820	3.020	0.111	0.119
E	1.500	1.700	0.059	0.067
E1	2.650	2.950	0.104	0.116
e	0.950(BSC)		0.037(BSC)	
e1	1.800	2.000	0.071	0.079
L	0.300	0.600	0.012	0.024
θ	0°	8°	0°	8°

3-pin SOT89 Outline Dimensions

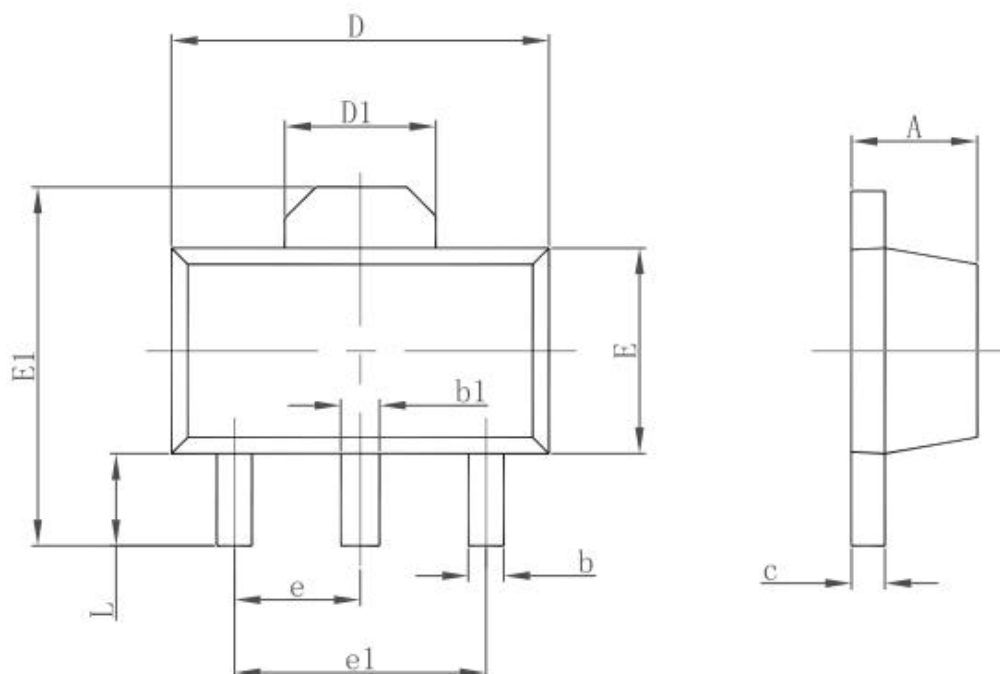

Symbol	Dimensions In Millimeters		Dimensions In Inches	
	Min.	Max.	Min.	Max.
A	1.400	1.600	0.055	0.063
b	0.320	0.520	0.013	0.020
b1	0.400	0.580	0.016	0.023
c	0.350	0.440	0.014	0.017
D	4.400	4.600	0.173	0.181
D1	1.550 REF.		0.061 REF.	
E	2.300	2.600	0.091	0.102
E1	3.940	4.250	0.155	0.167
e	1.500 TYP.		0.060 TYP.	
e1	3.000 TYP.		0.118 TYP.	
L	0.900	1.200	0.035	0.047

X-ON Electronics

Largest Supplier of Electrical and Electronic Components

Click to view similar products for [Linear Voltage Regulators](#) category:

Click to view products by [Suntek](#) manufacturer:

Other Similar products are found below :

[LV5684PVD-XH](#) [MCDTSA6-2R](#) [L7815ACV-DG](#) [LV56801P-E](#) [UA7805CKC](#) [714954EB](#) [ZMR500QFTA](#) [BA033LBSG2-TR](#)
[NCV78M05ABDTRKG](#) [LV5680P-E](#) [L79M05T-E](#) [L78LR05D-MA-E](#) [NCV317MBTG](#) [NTE7227](#) [MP2018GZD-33-P](#) [MP2018GZD-5-P](#)
[LV5680NPVC-XH](#) [ZTS6538SE](#) [UA78L09CLP](#) [UA78L09CLPR](#) [CAT6221-PPTD-GT3](#) [MC78M09CDTRK](#) [NCV51190MNTAG](#)
[BL1118CS8TR1833](#) [BL8563CKETR18](#) [BL8077CKETR33](#) [BL9153-33CC3TR](#) [BL9161G-15BADRN](#) [BL9161G-28BADRN](#)
[BRCO7530MMC](#) [CJ7815B-TFN-ARG](#) [LM317C](#) [GM7333K](#) [GM7350K](#) [XC6206P332MR](#) [HT7533](#) [LM7912S/TR](#) [LT1764S/TR](#) [LM7805T](#)
[LM338T](#) [LM1117IMP-3.3/TR](#) [HT1117AM-3.3](#) [HT7550S](#) [AMS1117-3.3](#) [HT7150S](#) [78L12](#) [HT7550](#) [HT7533-1](#) [HXY6206I-2.5](#) [HT7133](#)