

SK6513S

High Voltage, Low Power LDO

DESCRIPTION

The SK6513S is a high voltage, low power consumption and high performance LDO. The family uses an advanced CMOS process and a PMOSFET pass device to achieve fast start-up, with high output voltage accuracy. The SK6513S is stable with a 1.0 μF ~ 10 μF ceramic output capacitor, and uses a precision voltage reference and feedback loop to achieve a worst-case accuracy of 2% over all load, line, process, and temperature variations.

FEATURES

- Wide Input Voltage Range: up to 45 V
- Output Current: 350 mA
- Standard Fixed Output Voltage Options: 1.8 V, 2.5 V, 3.0 V, 3.3 V, 3.6 V and 5.0 V
- Other Output Voltage Options Available on Request
- Low IQ: 2.6 μA
- Low Dropout Voltage
- Short current protection: 150 mA
- Excellent Load / Line Transient Response
- Line Regulation: 0.01 %/V typical
- Package: DFN1 \times 1-4, SOT23-3, SOT23-5, SOT89-3

ORDER INFORMATION

Ordering Number	Package	Tape and Reel
SK6513SD4-XX	DFN1 \times 1-4	10000/Reel
SK6513SS3-XX	SOT23-3	3000/Reel
SK6513SS5E-XX	SOT23-5	3000/Reel
SK6513ST3A-XX	SOT89-3	1000/Reel
SK6513ST3B-XX(L-Type)	SOT89-3	1000/Reel

*XX: When expressed as 18, the output voltage is 1.8 V; when expressed as 30 the output voltage is 3.0 V.

PIN CONFIGURATION (Top View)

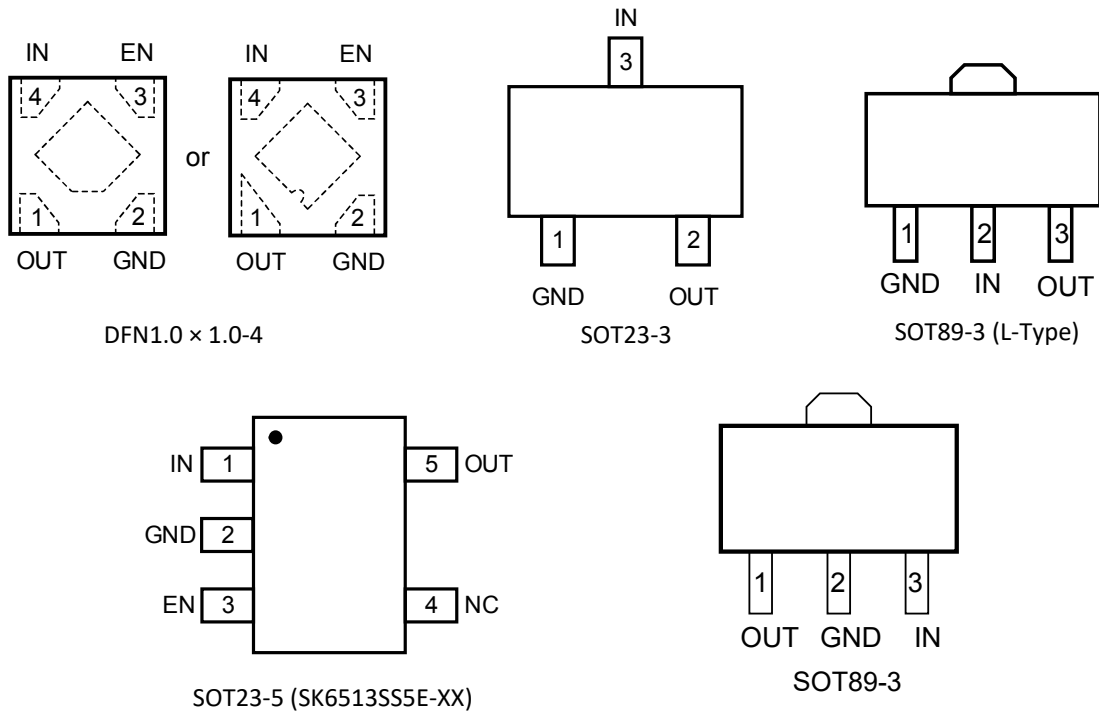

PIN DESCRIPTIONS

Pin					Symbol	Description
DFN1×1-4 (SK6513SD4-XX)	SOT23-3 (SK6513SS3-XX)	SOT23-5 (SK6513SS5E-XX)	SOT89-3 (SK6513ST3A-XX)	SOT89-3 (SK6513ST3B-XX)		
1	2	5	1	3	OUT	Output pin.
2	1	2	2	1	GND	Ground.
3		3			EN	Enable control input, active high.
4	3	1	3	2	IN	Supply input pin.
		4			NC	No connection.

BLOCK DIAGRAM

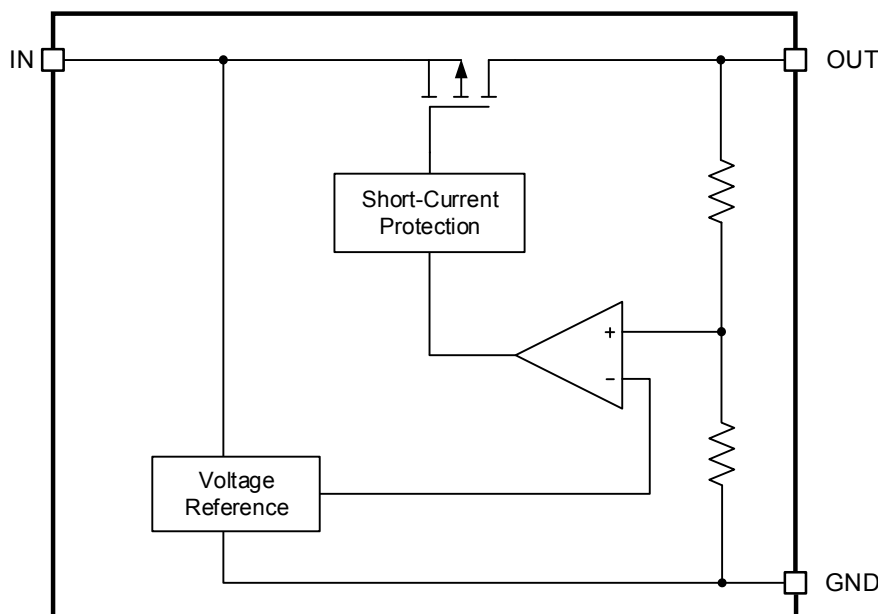

FUNCTIONAL DESCRIPTION

Input Capacitor

A $1\ \mu\text{F} \sim 10\ \mu\text{F}$ ceramic capacitor is recommended to connect between IN and GND pins to decouple input power supply glitch and noise. The amount of the capacitance may be increased without limit. This input capacitor must be located as close as possible to the device to assure input stability and less noise. For PCB layout, a wide copper trace is required for both IN and GND.

Output Capacitor

An output capacitor is required for the stability of the LDO. The recommended output capacitance is from $1\ \mu\text{F}$ to $10\ \mu\text{F}$, Equivalent Series Resistance (ESR) is from $5\ \text{m}\Omega$ to $100\ \text{m}\Omega$, and temperature characteristics are X7R or X5R. Higher capacitance values help to improve load / line transient response. The output capacitance may be increased to keep low undershoot / overshoot. Place output capacitor as close as possible to OUT and GND pins.

Low Quiescent Current

The SK6513S, consuming only around $2.6\ \mu\text{A}$ for all input range and output loading, provides great power saving in portable and low power applications.

Short Current Limit Protection

When output current at the OUT pin is higher than current limit threshold or the OUT pin is short-circuit to GND, the short current limit protection will be triggered and clamp the output current to approximately $100\ \text{mA}$ to prevent over-current and to protect the regulator from damage due to overheating.

ABSOLUTE MAXIMUM RATINGS

Parameter	Rating		Unit
IN pin to GND pin	-0.3 to 48		V
OUT pin to GND pin	-0.3 to 6		V
Thermal Resistance (Junction to Ambient)	DFN1 ×1-4	250	°C/W
	SOT23-3	360	
	SOT23-5	250	
	SOT89-3	135	
Operating Junction Temperature	-40 to 125		°C
Storage Temperature	-65 to 150		°C
Lead Temperature (Soldering, 10 sec)	300		°C
ESD (HBM mode) ESDA/JEDEC JS-001-2017	±2000		V

NOTE:

Stresses beyond those listed under “ABSOLUTE MAXIMUM RATINGS” may cause permanent damage to the device. These are stress ratings only, and functional operation of the device at these or any other conditions beyond those indicated in the operational sections of the specifications is not implied. Exposure to absolute maximum rating conditions for extended periods may affect device reliability.

CAUTION

This integrated circuit can be damaged by ESD if you don't pay attention to ESD protection. SUNTEK recommends that all integrated circuits be handled with appropriate precautions. Failure to observe proper handling and installation procedures can cause damage. ESD damage can range from subtle performance degradation to complete device failure. Precision integrated circuits may be more susceptible to damage because very small parametric changes could cause the device not to meet its published specifications. SUNTEK reserves the right to make any change in circuit design, specification or other related things if necessary without notice at any time. Please contact SUNTEK sales office to get the latest datasheet.

ELECTRICAL CHARACTERISTICS

$V_{IN} = V_{OUT} + 2\text{ V}$; $I_{OUT} = 10\text{ mA}$, $C_{IN} = C_{OUT} = 1.0\ \mu\text{F}$, unless otherwise noted. Typical values are at $T_A = +25^\circ\text{C}$.

Parameter	Symbol	Test Conditions	Min	Typ	Max	Unit
Operating Input Voltage	V_{IN}				45	V
Line Regulation	Reg_{LINE}	$2.5\text{ V} \leq V_{IN} \leq 36\text{ V}$, $I_{OUT} = 10\text{ mA}$		0.01	0.04	%/V
Dropout Voltage	V_{DROP}	$V_{OUT} = 3.0\text{ V}$, $I_{OUT} = 100\text{ mA}$		330		mV
		$V_{OUT} = 3.0\text{ V}$, $I_{OUT} = 200\text{ mA}$		690		
Load Regulation	Reg_{LOAD}	$1\text{ mA} \leq I_{OUT} \leq 300\text{ mA}$, $V_{IN} = V_{OUT} + 2\text{ V}$			40	mV
Maximum Output Current	I_{OUT}	$V_{IN} = V_{OUT} + 1\text{ V}$	350			mA
Quiescent Current	I_Q	$I_{OUT} = 0\text{ mA}$		2.6	4	μA
Standby Current	I_{Q_OFF}	$V_{EN} = 0\text{ V}$, $T_A = 25^\circ\text{C}$		0.1	1	μA
EN Pin Threshold Voltage	V_{ENH}	EN Input Voltage "H"	1.2			V
EN Pin Threshold Voltage	V_{ENL}	EN Input Voltage "L"			0.4	V
EN Pin Current	I_{EN}	$V_{\text{EN}} = 0\text{ V to } 36\text{ V}$		1		μA
Power Supply Rejection Ratio	PSRR	$V_{IN} = V_{OUT} + 1\text{ V}$, $I_{OUT} = 20\text{ mA}$, $f = 1\text{ kHz}$		60		dB
Output Noise Voltage	e_N	$V_{IN} = V_{OUT} + 2\text{ V}$, $I_{OUT} = 1\text{ mA}$, $f = 10\text{ Hz to } 100\text{ kHz}$, $V_{OUT} = 3\text{ V}$, $C_{OUT} = 1\ \mu\text{F}$		100		μV_{RMS}
Thermal Shutdown Temperature	T_{SD}	Temperature Increasing from $T_A = +25^\circ\text{C}$		155		$^\circ\text{C}$
Thermal Shutdown Hysteresis	T_{SDH}	Temperature Falling from TSD		20		$^\circ\text{C}$

TYPICAL PERFORMANCE CHARACTERISTICS

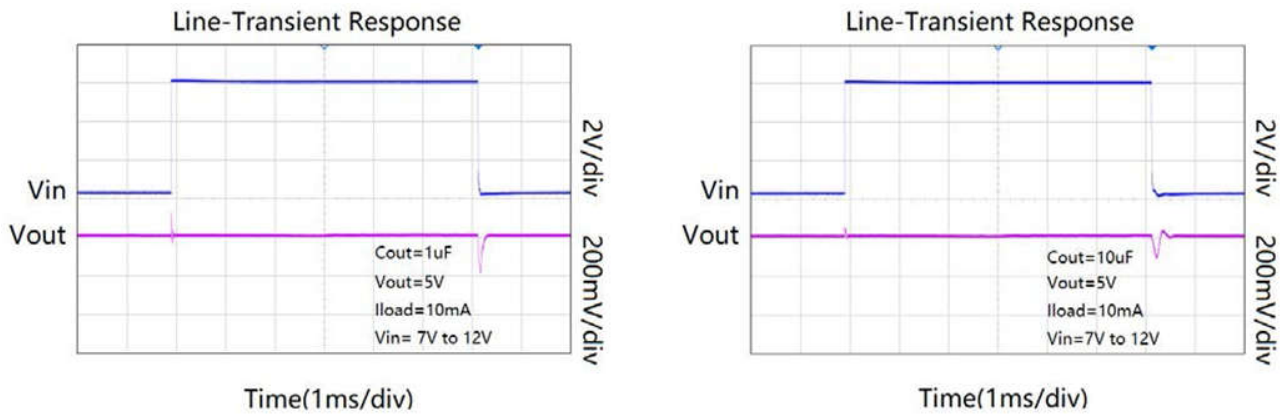

Figure 1. Line-Transient Response

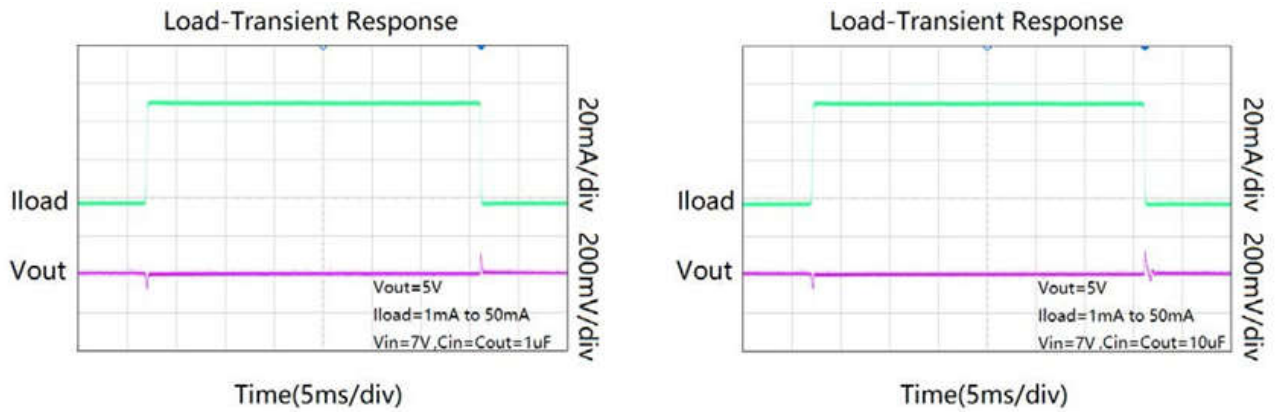

Figure 2. Load-Transient Response

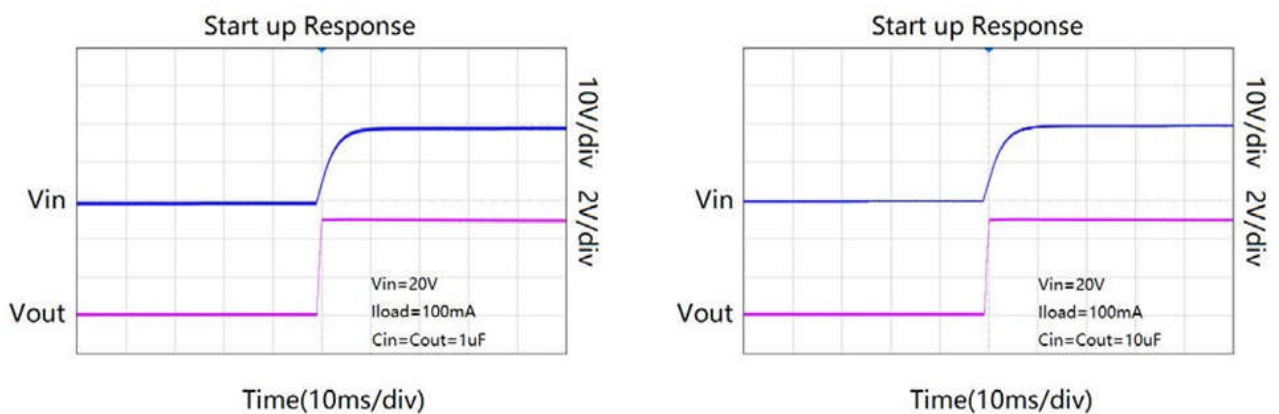

Figure 3. Start up Response

TYPICAL PERFORMANCE CHARACTERISTICS (continued)

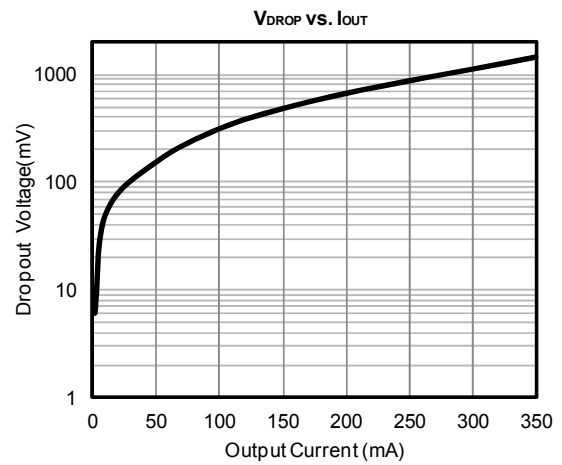
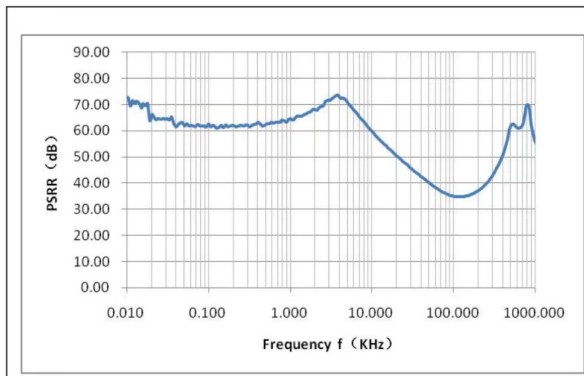

Figure 4. Dropout Voltage vs. Output Current

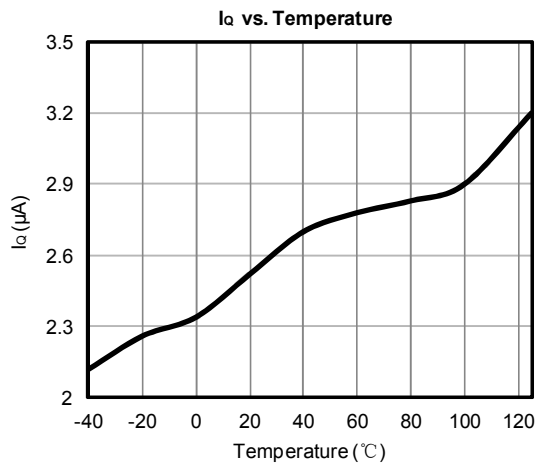
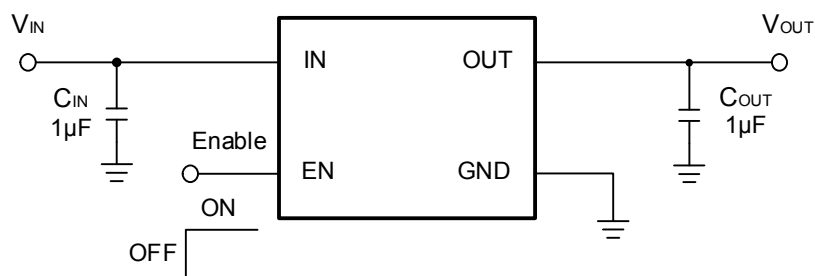

Figure 5. I_Q vs. Temperature

APPLICATION CIRCUITS



PACKAGE OUTLINE

DFN1×1-4

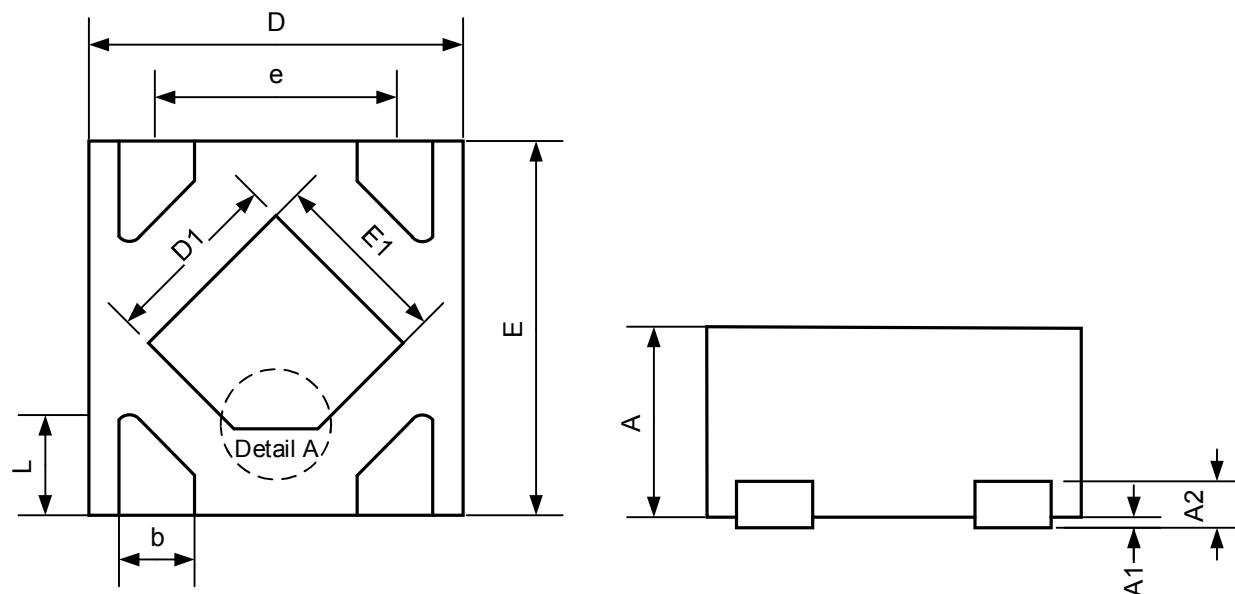

Detail A:



Note: Detail A has two kinds of shapes

Symbol	Dimensions In Millimeters	
	Min	Max
A		0.500
A1	0.000	0.050
A2	0.125REF	
b	0.150	0.250
D	0.950	1.050
D1	0.380	0.580
E	0.950	1.050
E1	0.380	0.580
e	0.650BSC	
L	0.150	0.350

PACKAGE OUTLINE

SOT23-3

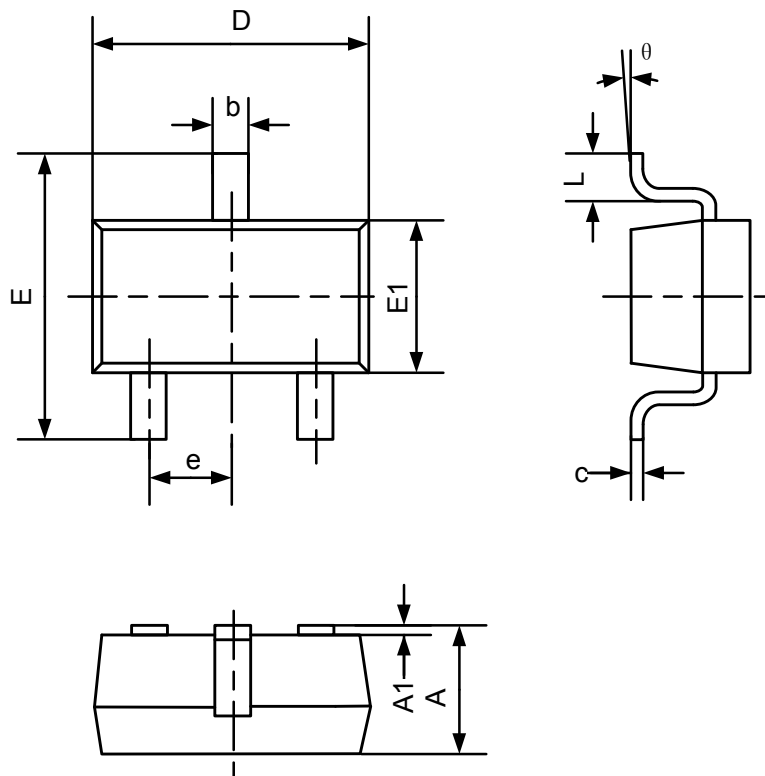

Symbol	Dimensions In Millimeters	
	Min	Max
A	1.050	1.250
A1	0.000	0.100
b	0.300	0.500
c	0.100	0.200
D	2.820	3.020
E	2.650	2.950
E1	1.500	1.700
e	0.950BSC	
L	0.300	0.600
θ	0°	8°

PACKAGE OUTLINE

SOT23-5

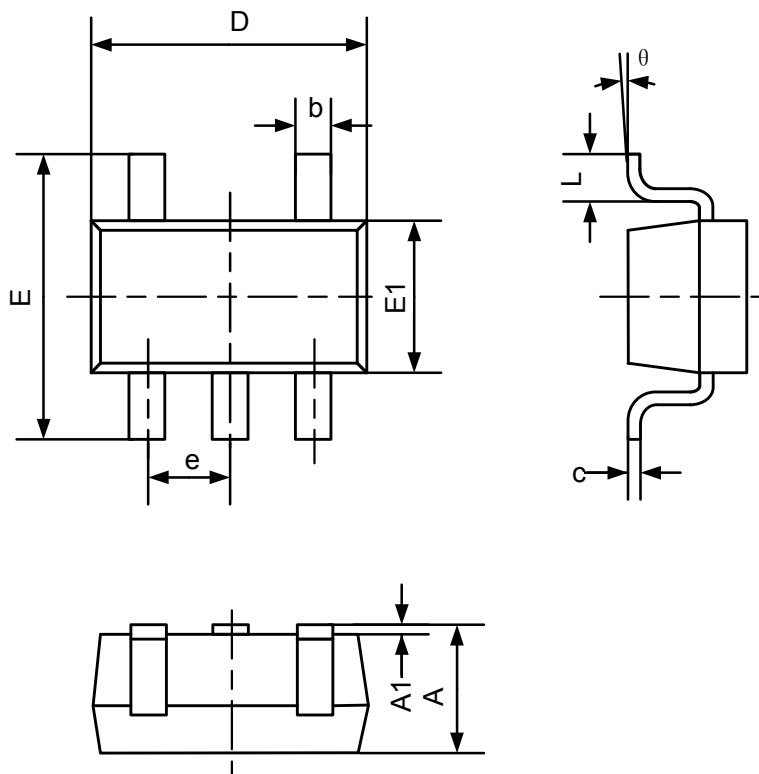

Symbol	Dimensions In Millimeters	
	Min	Max
A	1.050	1.250
A1	0.000	0.100
b	0.300	0.500
c	0.100	0.200
D	2.820	3.020
E	2.650	2.950
E1	1.500	1.700
e	0.950BSC	
L	0.300	0.600
θ	0°	8°

PACKAGE OUTLINE

SOT89-3

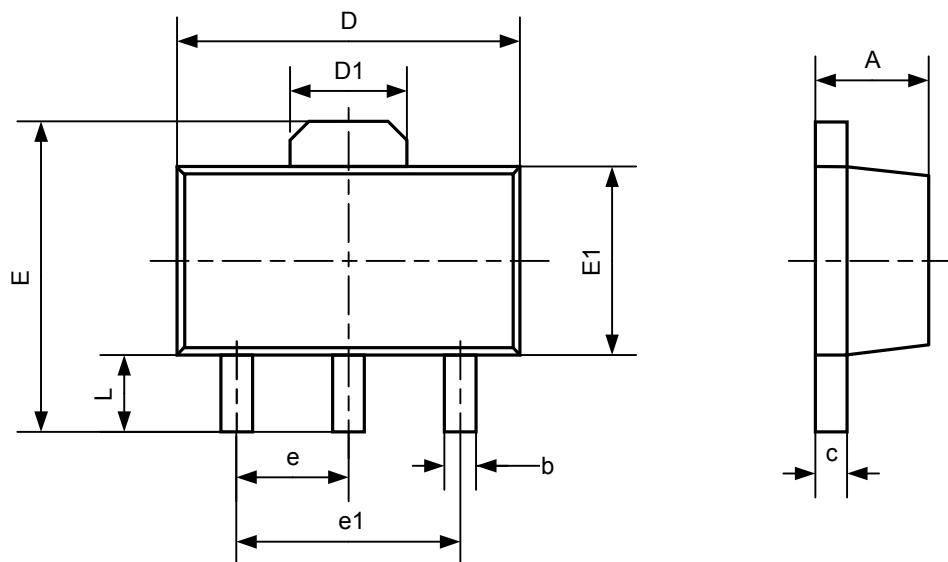

Symbol	Dimensions In Millimeters	
	Min	Max
A	1.400	1.600
b	0.320	0.520
c	0.350	0.440
D	4.400	4.600
D1	1.550REF	
E	3.940	4.250
E1	2.300	2.600
e	1.500BSC	
e1	3.000BSC	
L	0.900	1.200

X-ON Electronics

Largest Supplier of Electrical and Electronic Components

Click to view similar products for [Linear Voltage Regulators](#) category:

Click to view products by [Suntek](#) manufacturer:

Other Similar products are found below :

[LV56831P-E](#) [LV5684PVD-XH](#) [MCDTSA6-2R](#) [L7815ACV-DG](#) [PQ3DZ53U](#) [LV56801P-E](#) [TLE42794G](#) [L78L05CZ/1SX](#) [L78LR05DL-MA-E](#) [636416C](#) [714954EB](#) [BA033LBSG2-TR](#) [LV5680P-E](#) [L78M15CV-DG](#) [L79M05T-E](#) [TLS202A1MBVHTSA1](#) [L78LR05D-MA-E](#) [NCV317MBTG](#) [NTE7227](#) [LV5680NPVC-XH](#) [LT1054CN8](#) [MP2018GZD-5-Z](#) [MP2018GZD-33-Z](#) [MIC5281-3.3YMM](#) [MC78L06BP-AP](#) [TA48LS05F\(TE85L,F\)](#) [TA78L12F\(TE12L,F\)](#) [TC47BR5003ECT](#) [TCR2LN12,LF\(S](#) [TCR2LN28,LF\(S](#) [TCR2LN30,LF\(S](#) [TCR3DF295,LM\(CT](#) [TCR3DF40,LM\(CT](#) [BA178M20CP-E2](#) [L78M12ABDT](#) [LM7812SX/NOPB](#) [LR645N3-G-P003](#) [LR645N3-G-P013](#) [ZXTR2005P5-13](#) [SCD7812BTG](#) [TCR3DF335,LM\(CT](#) [ZXTR2012K-13](#) [TLE42994E V33](#) [ZXTR2008K-13](#) [ZXTR2005K-13](#) [L88R05DL-E](#) [ADP3300ARTZ-2.7RL7](#) [LM120K-15/883](#) [IFX54441LDVXUMA1](#) [LM317D2T-TR](#)