

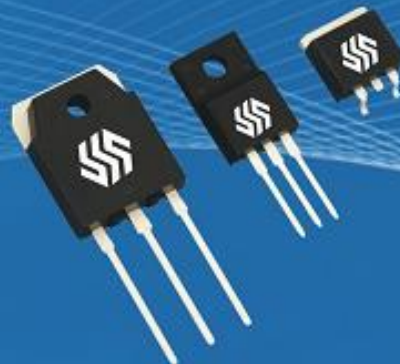

SUPER-SEMI



SUPER-MOSFET

Super Gate Metal Oxide Semiconductor Field Effect Transistor

100V Super Gate Power Transistor
SG*100N45T

Rev. 1.0
Dec. 2016

www.supersemi.com.cn

SGT100N45T/SGP100N45T 100V N-Channel MOSFET

Description

The SG-MOSFET uses trench MOSFET technology that is uniquely optimized to provide the most efficient high frequency switching performance. Both conduction and switching power losses are minimized due to an extremely low combination of RDS(ON), Ciss and Coss. This device is ideal for boost converters and synchronous rectifiers for consumer, telecom, industrial power supplies and LED backlighting.

Features

- VDS 100V
- ID (at Vgs=10V) 25A
- RDS(on) (at Vgs=10V) <45mΩ
- 100% avalanche tested

SGT100N45T

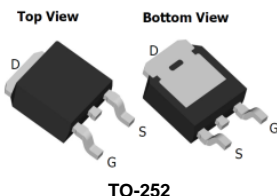

SGP100N45T

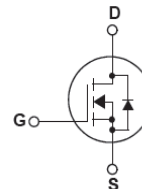
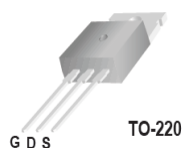

Absolute Maximum Ratings

Symbol	Parameter	SGT_P100N45T	Unit
V _{DS}	Drain-Source Voltage	100	V
I _D	Drain Current -Continuous (TA = 25°C) -Continuous (TA = 100°C)	25* 16*	A
I _{DM}	Drain Current - Pulsed (Note 1)	100*	A
V _{GS}	Gate-Source voltage	±20	V
I _{AS}	Avalanche Current, single pulse (Note 1)	27	A
E _{AS}	Avalanche Energy, single pulse, L=0.5mH (Note 1)	360	mJ
P _D	Power Dissipation - TA = 25°C (Note 2)	40	W
T _J , T _{STG}	Operating and Storage Temperature Range	-55 to +150	°C

* Drain current limited by maximum junction temperature.

Thermal Characteristics

Symbol	Parameter	SGT_P100N45T	Unit
R _{θJC}	Thermal Resistance, Junction-to-Case	3.1	°C/W
R _{θCS}	Thermal Resistance, Case-to-Sink Typ.	0.5	°C/W
R _{θJA}	Thermal Resistance, Junction-to-Ambient	62	°C/W



Electrical Characteristics $T_J = 25^{\circ}\text{C}$ unless otherwise noted

SGT100N45T/SGP100N45T 100V N-Channel MOSFET

Symbol	Parameter	Conditions	Min	Typ	Max	Unit
Off Characteristics						
BV_{DSS}	Drain-Source Breakdown Voltage	$V_{GS} = 0V, I_D = 250\mu A, T_J = 25^{\circ}\text{C}$	100	115	-	V
I_{DSS}	Zero Gate Voltage Drain Current	$V_{DS} = 100V, V_{GS} = 0V$ $-T_J = 125^{\circ}\text{C}$	-	- 10	1 -	μA μA
I_{GSSF}	Gate-Body Leakage Current, Forward	$V_{GS} = 20V, V_{DS} = 0V$	-	-	100	nA
I_{GSSR}	Gate-Body Leakage Current, Reverse	$V_{GS} = -20V, V_{DS} = 0V$	-	-	-100	nA
On Characteristics						
$V_{GS(th)}$	Gate Threshold Voltage	$V_{DS} = V_{GS}, I_D = 250\mu A$	2.3	3.2	4.1	V
$R_{DS(on)}$	Static Drain-Source On-Resistance	$V_{GS} = 10V, I_D = 12A$ $V_{GS} = 6V, I_D = 6A$	-	38 48	45 62	m Ω
g_{FS}	Forward Transconductance	$V_{DS} = 5V, I_D = 12A$	-	16	-	S
R_g	Gate resistance	$V_{GS}=0V, V_{DS}=0V, f=1\text{MHz}$	-	1.5	-	Ω
Dynamic Characteristics						
C_{iss}	Input Capacitance	$V_{DS} = 50V, V_{GS} = 0V,$ $f=1\text{MHz}$	-	890	-	pF
C_{oss}	Output Capacitance		-	60	-	pF
C_{rss}	Reverse Transfer Capacitance		-	40	-	pF
Switching Characteristics						
$t_{d(on)}$	Turn-On Delay Time	$V_{DS} = 50V, R_G = 3\Omega,$ $I_D = 6A, V_{GS} = 10V$ (Note 3, 4)	-	9	-	ns
t_r	Turn-On Rise Time		-	5	-	ns
$t_{d(off)}$	Turn-Off Delay Time		-	18	-	ns
t_f	Turn-Off Fall Time		-	5	-	ns
Q_g	Total Gate Charge	$V_{DS} = 50V, I_D = 6A,$ $V_{GS} = 0\sim 10V$ (Note 3, 4)	-	14	-	nC
Q_{gs}	Gate-Source Charge		-	4	-	nC
Q_{gd}	Gate-Drain Charge		-	5	-	nC
Drain-Source Diode Characteristics and Maximum Ratings						
I_S	Maximum Continuous Drain-Source Diode Forward Current		-	-	25	A
I_{SM}	Maximum Pulsed Drain-Source Diode Forward Current		-	-	100	A
V_{SD}	Drain-Source Diode Forward Voltage	$V_{GS} = 0V, I_S = 1A$	-	0.7	1.0	V
t_{rr}	Reverse Recovery Time	$V_{GS} = 0V, V_R=50V, I_S = 6A$ $dI_F/dt = 500A/\mu s$ (Note 3)	-	44	-	ns
Q_{rr}	Reverse Recovery Charge		-	60	-	nC

NOTES:

1. Repetitive Rating: Pulse width limited by maximum junction temperature $T_J(MAX)=150^{\circ}\text{C}$. Ratings are based on low frequency and duty cycles to keep initial $T_J=25^{\circ}\text{C}$.
2. The power dissipation PD is based on $T_J(MAX)=150^{\circ}\text{C}$, using $\leq 10\text{s}$ junction-to-ambient thermal resistance.
3. Pulse Test: Pulse width $\leq 300\mu s$, Duty Cycle $\leq 2\%$
4. Essentially Independent of Operating Temperature Typical Characteristics

Typical Performance Characteristics

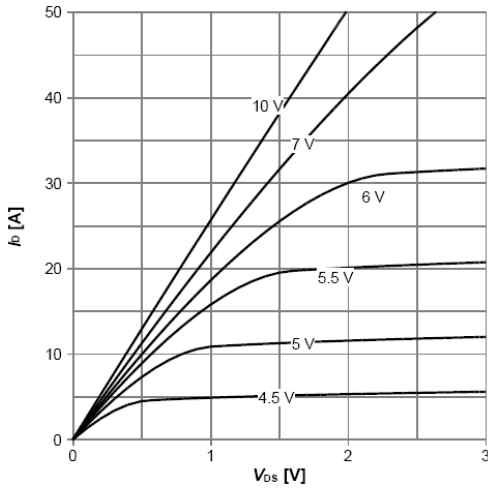

Figure 1: On-Region Characteristics

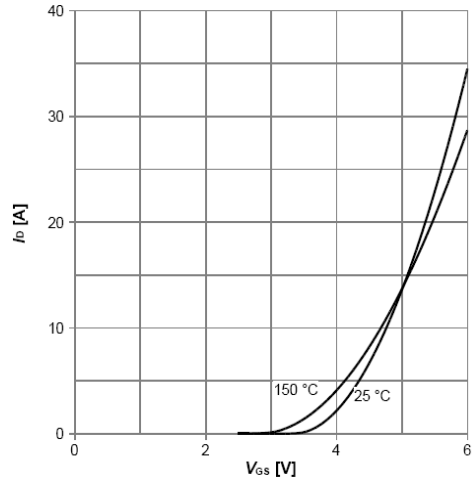

Figure 2: Transfer Characteristics

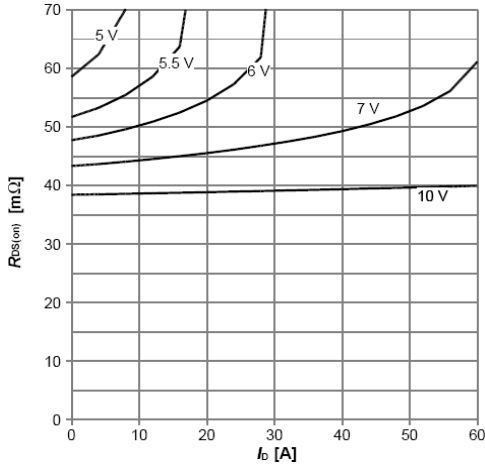

Figure 3: On-Resistance vs Drain current and Gate voltage

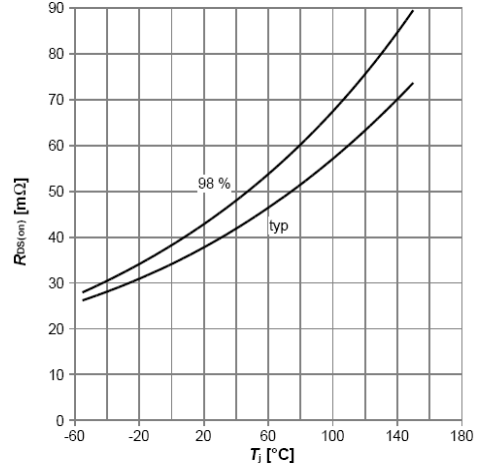

Figure 4: On-Resistance vs Junction Temperature

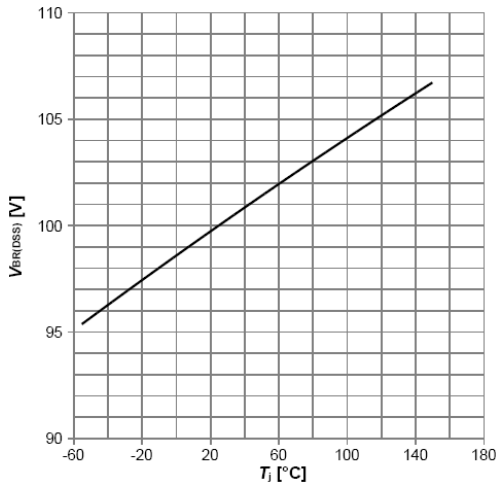

Figure 5: Drain-Source breakdown voltage

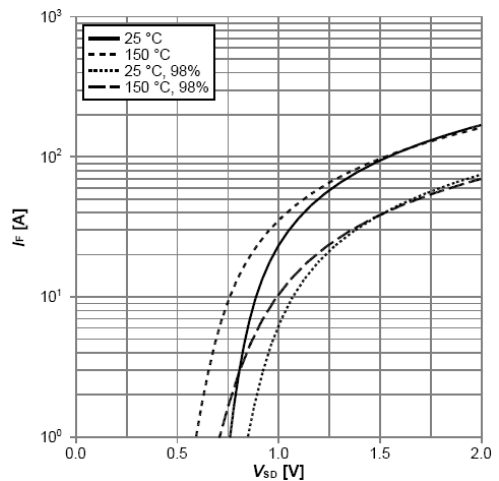

Figure 6: Body-Diode Characteristics

Typical Performance Characteristics

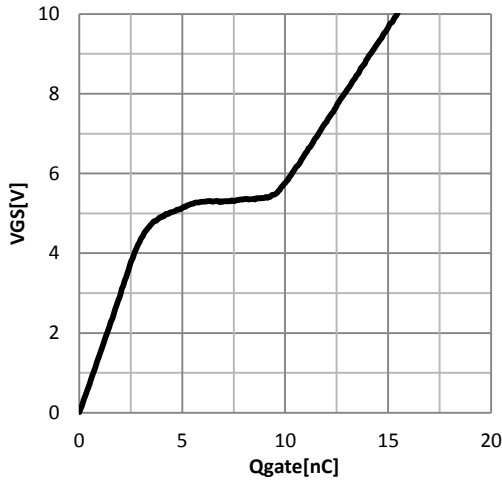

Figure 7: Gate-Charge Characteristics

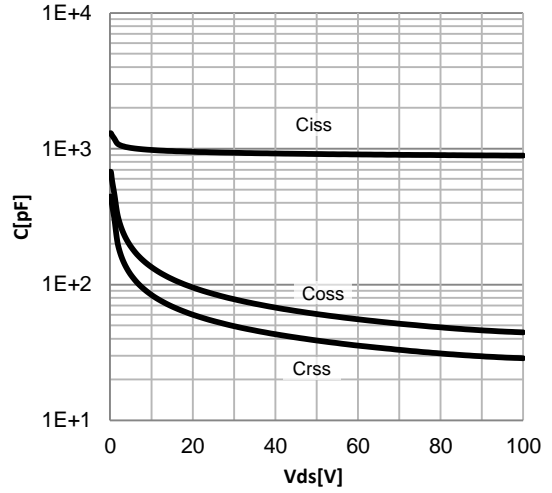

Figure 8: Capacitance Characteristics

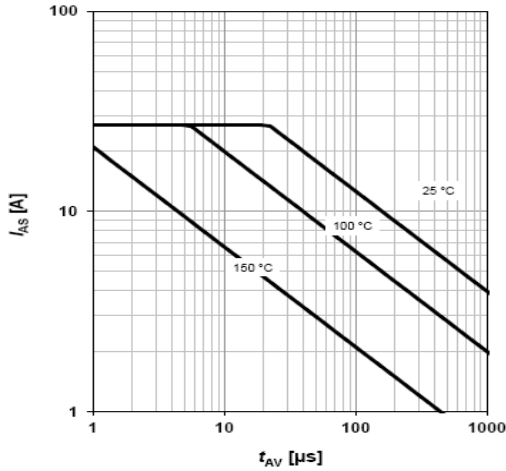

Figure 9: Avalanche Characteristics

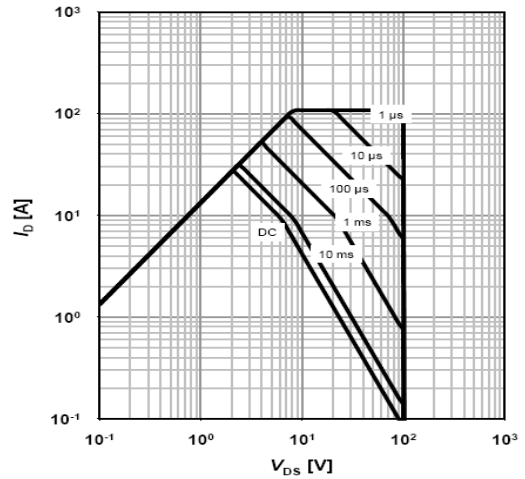

Figure 10: Maximum Forward Biased Safe Operating Area

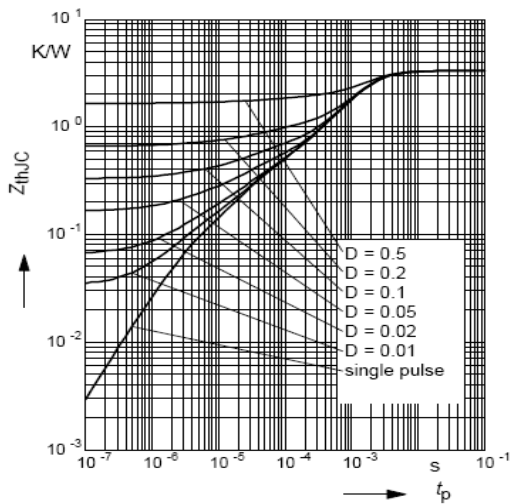
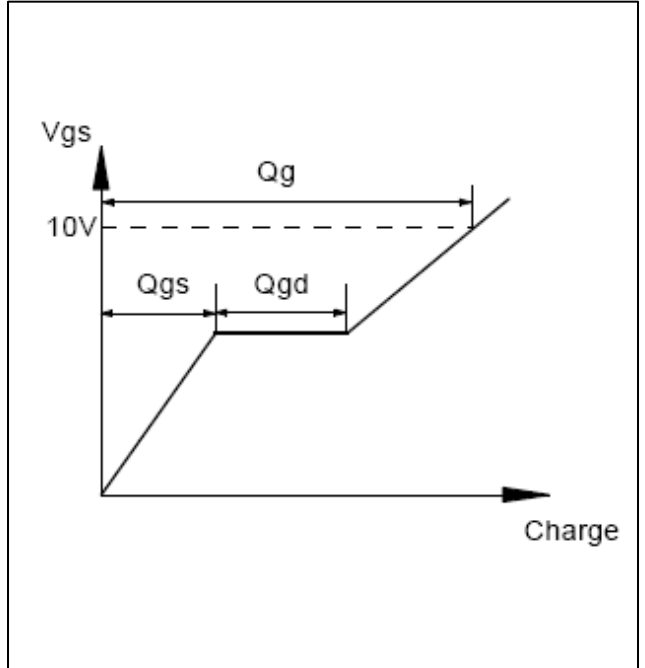
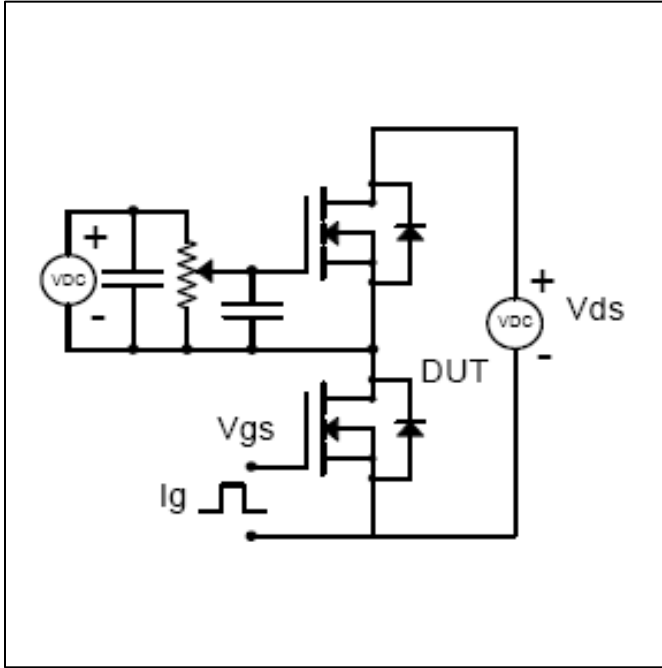
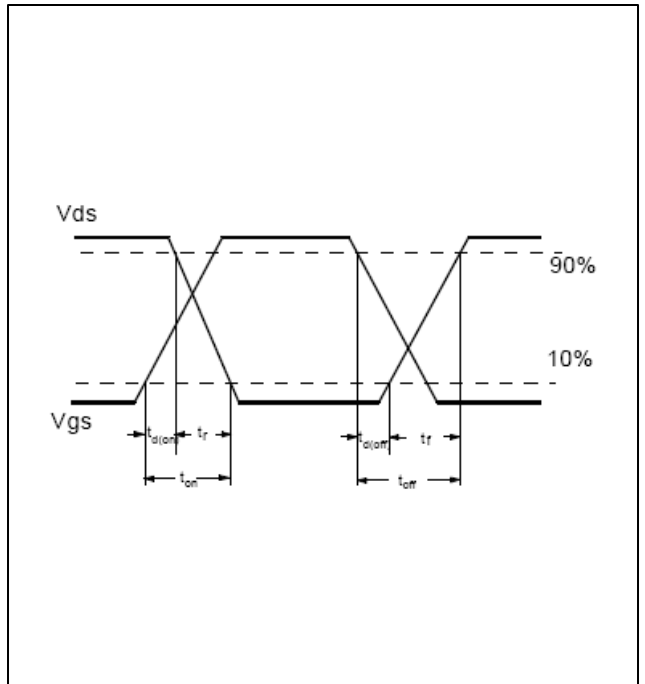
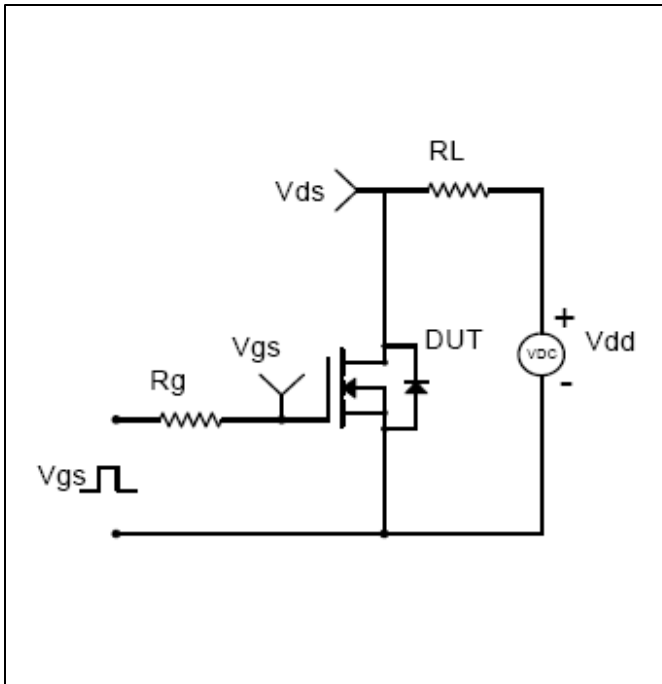

Figure 11: Maximum Transient Thermal Impedance

Gate Charge Test Circuit and Waveform



Resistive Switching Test Circuit and Waveforms



Unclamped Inductive Switching (UIS) Test Circuit & Waveforms

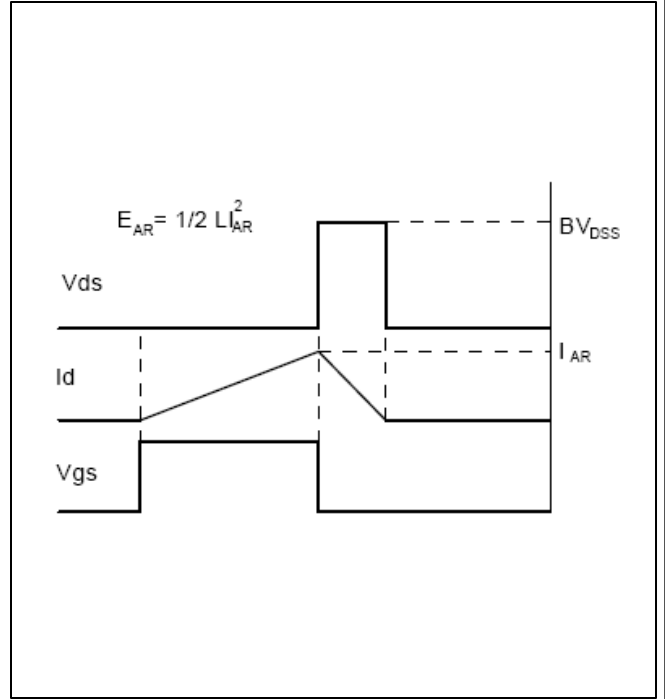
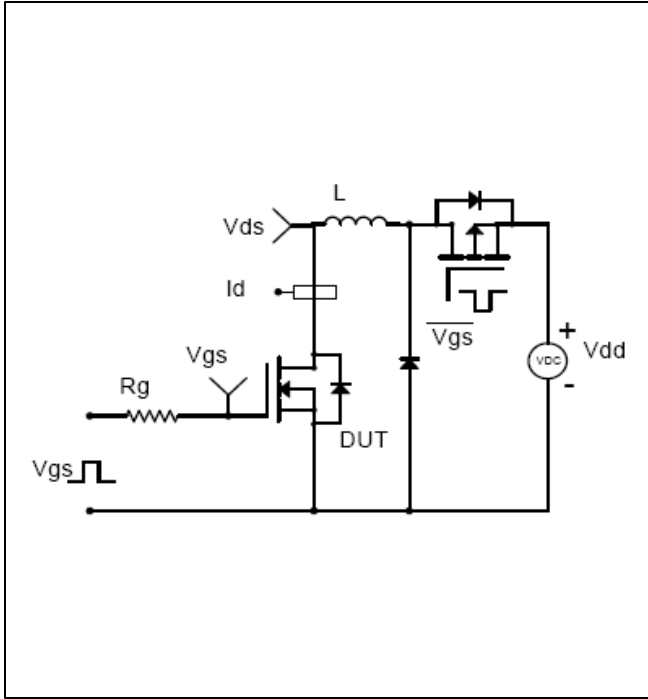

Diode Recovery Test Circuit & Waveforms

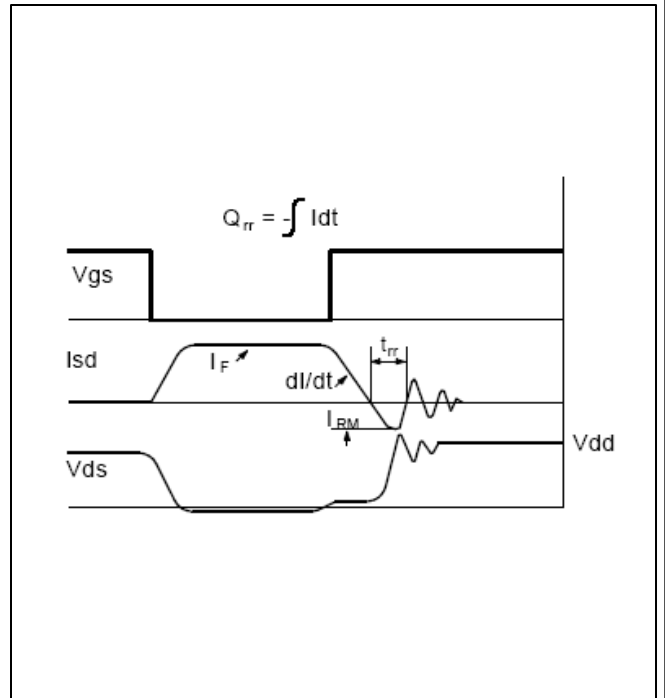
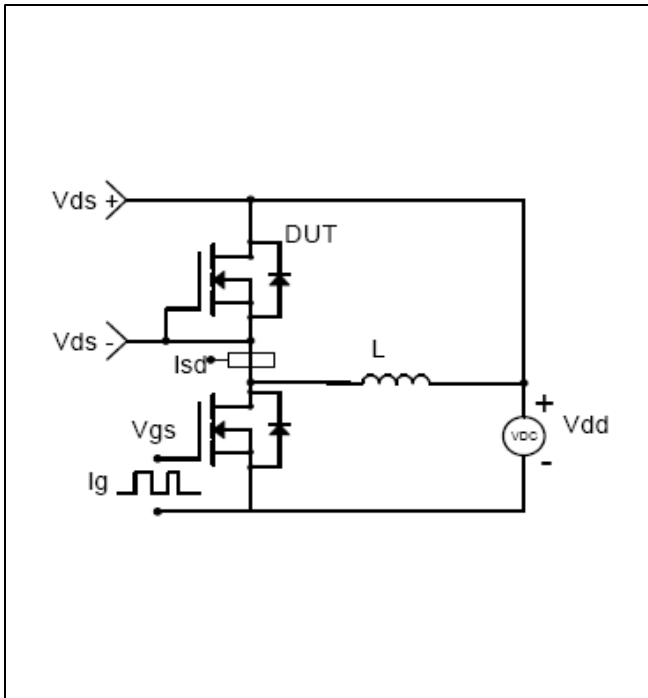

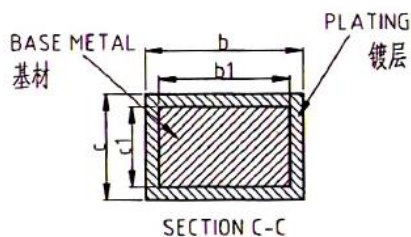
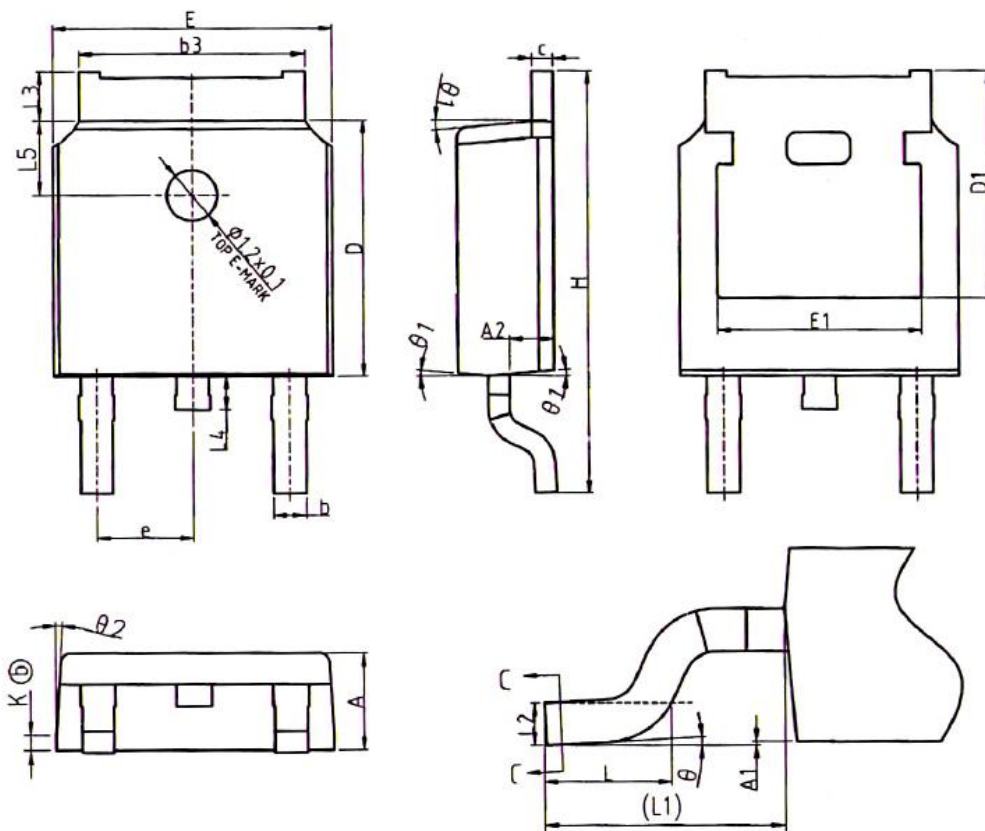

COMMON DIMENSIONS

SYMBOL	MM		
	MIN	NOM	MAX
A	2.20	2.30	2.38
A1	0.00	-	0.10
A2	0.97	1.07	1.17
b	0.72	0.78	0.85
b1	0.71	0.76	0.81
b3	5.23	5.33	5.46
c	0.47	0.53	0.58
c1	0.46	0.51	0.56
D	6.00	6.10	6.20
D1	5.30REF		
E	6.50	6.60	6.70
E1	4.70	4.83	4.92
e	2.286BSC		
H	9.90	10.10	10.30
L	1.40	1.50	1.70
L1	2.90REF		
L2	0.51BSC		
L3	0.90	-	1.25
L4	0.60	0.80	1.00
L5	1.70	1.80	1.90
θ	0°	-	8°
$\theta 1$	5°	7°	9°
$\theta 2$	5°	7°	9°
K	0.40REF		

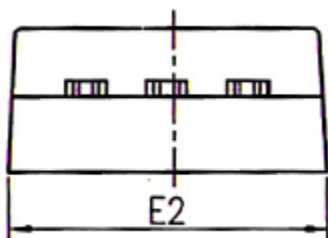
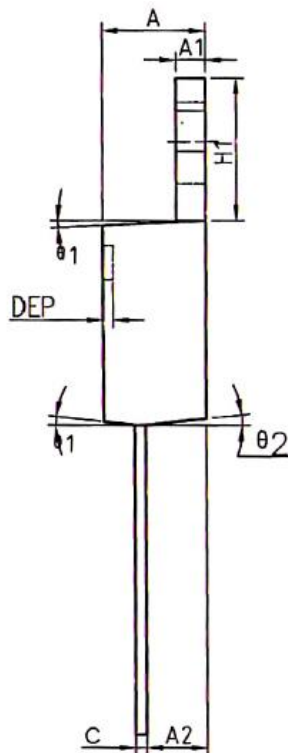
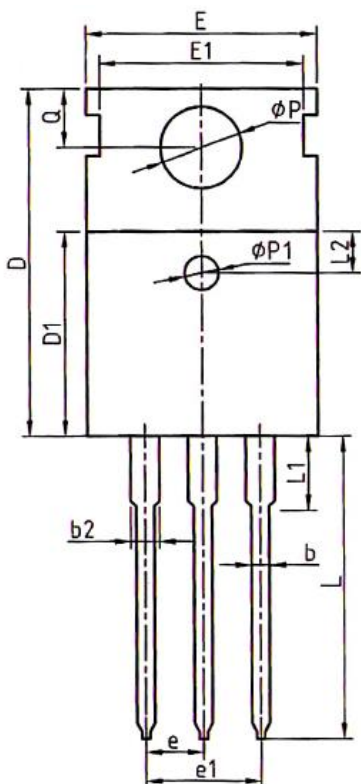

COMMON DIMENSIONS

SYMBOL	MM		
	MIN	NDM	MAX
A	4.40	4.57	4.70
A1	1.27	1.30	1.37
A2	2.35	2.40	2.50
b	0.77	0.80	0.90
b2	1.17	1.27	1.36
c	0.48	0.50	0.56
D	15.40	15.60	15.80
D1	9.00	9.10	9.20
DEP	0.05	0.10	0.20
E	9.80	10.00	10.20
E1	-	8.70	-
E2	9.80	10.00	10.20
$\phi P1$	1.40	1.50	1.60
e	2.54BSC		
e1	5.08BSC		
H1	6.40	6.50	6.60
L	12.75	13.50	13.65
L1	-	3.10	3.30
L2	2.50REF		
ϕP	3.50	3.60	3.63
Q	2.73	2.80	2.87
$\theta 1$	5°	7°	9°
$\theta 2$	1°	3°	5°
$\theta 3$	1°	3°	5°

X-ON Electronics

Largest Supplier of Electrical and Electronic Components

Click to view similar products for [MOSFET](#) category:

Click to view products by [Super Semiconductor](#) manufacturer:

Other Similar products are found below :

[614233C](#) [648584F](#) [MCH3443-TL-E](#) [MCH6422-TL-E](#) [FDPF9N50NZ](#) [FW216A-TL-2W](#) [FW231A-TL-E](#) [APT5010JVR](#) [NTNS3A92PZT5G](#)
[IRF100S201](#) [JANTX2N5237](#) [2SK2464-TL-E](#) [2SK3818-DL-E](#) [FCA20N60_F109](#) [FDZ595PZ](#) [STD6600NT4G](#) [FSS804-TL-E](#) [2SJ277-DL-E](#)
[2SK1691-DL-E](#) [2SK2545\(Q,T\)](#) [D2294UK](#) [405094E](#) [423220D](#) [MCH6646-TL-E](#) [TPCC8103,L1Q\(CM](#) [367-8430-0972-503](#) [VN1206L](#)
[424134F](#) [026935X](#) [051075F](#) [SBVS138LT1G](#) [614234A](#) [715780A](#) [NTNS3166NZT5G](#) [751625C](#) [873612G](#) [IRF7380TRHR](#)
[IPS70R2K0CEAKMA1](#) [RJK60S3DPP-E0#T2](#) [RJK60S5DPK-M0#T0](#) [APT5010JVFR](#) [APT12031JFLL](#) [APT12040JVR](#) [DMN3404LQ-7](#)
[NTE6400](#) [JANTX2N6796U](#) [JANTX2N6784U](#) [JANTXV2N5416U4](#) [SQM110N05-06L-GE3](#) [SIHF35N60E-GE3](#)