



SUPER-SEMI



## SUPER-MOSFET

Super Junction Metal Oxide Semiconductor Field Effect Transistor

500V Super Junction Power Transistor  
SS\*50R140S

Rev. 1.2  
May.2018

[www.supersemi.com.cn](http://www.supersemi.com.cn)

## SJ-FET

# SSF50R140S/SSP50R140S/SSW50R140S/SSA50R140S

## 500V N-Channel MOSFET

### Description

SJ-FET is new generation of high voltage MOSFET family that is utilizing an advanced charge balance mechanism for outstanding low on-resistance and lower gate charge performance.

This advanced technology has been tailored to minimize conduction loss, provide superior switching performance, and withstand extreme dv/dt rate and higher avalanche energy.

SJ-FET is suitable for various AC/DC power conversion in switching mode operation for higher efficiency.

### Features

- Multi-Epi process SJ-FET
- 550V @T<sub>J</sub> = 150 °C
- Typ. R<sub>DS(on)</sub> = 0.12Ω
- Ultra Low Gate Charge (typ. Q<sub>g</sub> = 30nC)
- 100% avalanche tested

SSF50R140S

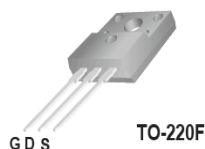

SSP50R140S

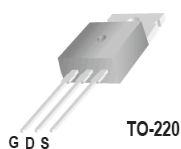

SSW50R140S



SSA50R140S

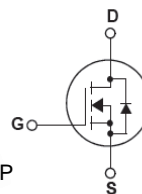
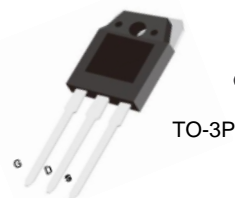

### Absolute Maximum Ratings

Symbol	Parameter	SSP_W_A50R140S	SSF50R140S	Unit
V <sub>DSS</sub>	Drain-Source Voltage	500		V
I <sub>D</sub>	Drain Current -Continuous (TC = 25°C) -Continuous (TC = 100°C)	24* 15*		A
I <sub>DM</sub>	Drain Current - Pulsed (Note 1)	70		A
V <sub>GSS</sub>	Gate-Source voltage	±30		V
E <sub>AS</sub>	Single Pulsed Avalanche Energy (Note 2)	485		mJ
I <sub>AR</sub>	Avalanche Current (Note 1)	3.5		A
E <sub>AR</sub>	Repetitive Avalanche Energy (Note 1)	1		mJ
dv/dt	Peak Diode Recovery dv/dt (Note 3)	15		V/ns
dV <sub>ds</sub> /dt	Drain Source voltage slope (V <sub>ds</sub> =400V)	50		V/ns
P <sub>D</sub>	Power Dissipation (TC = 25°C)	151	35	W
T <sub>J</sub> , T <sub>STG</sub>	Operating and Storage Temperature Range	-55 to +150		°C
T <sub>L</sub>	Max. Lead Temperature for Soldering Purpose, 1/8" from Case for 5 Seconds	300		°C

\* Drain current limited by maximum junction temperature. Maximum duty cycle D=0.75.

### Thermal Characteristics

Symbol	Parameter	SSP_W_A50R140S	SSF50R140S	Unit
R <sub>θJC</sub>	Thermal Resistance, Junction-to-Case	0.83	3.7	°C/W
R <sub>θCS</sub>	Thermal Resistance, Case-to-Sink Typ.	0.5	-	°C/W
R <sub>θJA</sub>	Thermal Resistance, Junction-to-Ambient	62	80	°C/W



# Electrical Characteristics TC = 25°C unless otherwise noted

SSF50R140S/SSP50R140S/SSW50R140S/SSA50R140S 500V N-Channel MOSFET

Symbol	Parameter	Conditions	Min	Typ	Max	Unit
<b>Off Characteristics</b>						
BV <sub>DSS</sub>	Drain-Source Breakdown Voltage	V <sub>GS</sub> = 0V, I <sub>D</sub> = 250μA, T <sub>J</sub> = 25°C	500	-	-	V
		V <sub>GS</sub> = 0V, I <sub>D</sub> = 250μA, T <sub>J</sub> = 150°C	-	550	-	V
ΔBV <sub>DSS</sub> /ΔT <sub>J</sub>	Breakdown Voltage Temperature Coefficient	I <sub>D</sub> = 250μA, Referenced to 25°C	-	0.6	-	V/°C
I <sub>DSS</sub>	Zero Gate Voltage Drain Current	V <sub>DS</sub> = 500V, V <sub>GS</sub> = 0V -T <sub>J</sub> = 150°C	-	- 10	1 -	μA μA
I <sub>GSSF</sub>	Gate-Body Leakage Current, Forward	V <sub>GS</sub> = 30V, V <sub>DS</sub> = 0V	-	-	100	nA
I <sub>GSSR</sub>	Gate-Body Leakage Current, Reverse	V <sub>GS</sub> = -30V, V <sub>DS</sub> = 0V	-	-	-100	nA
<b>On Characteristics</b>						
V <sub>GS(th)</sub>	Gate Threshold Voltage	V <sub>DS</sub> = V <sub>GS</sub> , I <sub>D</sub> = 250μA	2.5	-	4.5	V
R <sub>DS(on)</sub>	Static Drain-Source On-Resistance	V <sub>GS</sub> = 10V, I <sub>D</sub> = 12A	-	0.12	0.14	Ω
g <sub>FS</sub>	Forward Transconductance	V <sub>DS</sub> = 40V, I <sub>D</sub> = 20A	-	19	-	S
<b>Dynamic Characteristics</b>						
C <sub>iss</sub>	Input Capacitance	V <sub>DS</sub> = 25V, V <sub>GS</sub> = 0V, f = 1.0MHz	-	1440	-	pF
C <sub>oss</sub>	Output Capacitance		-	370	-	pF
C <sub>rss</sub>	Reverse Transfer Capacitance		-	11	-	pF
<b>Switching Characteristics</b>						
t <sub>d(on)</sub>	Turn-On Delay Time	V <sub>DD</sub> = 400V, I <sub>D</sub> = 12A R <sub>G</sub> = 20Ω (Note 4)	-	15	-	ns
t <sub>r</sub>	Turn-On Rise Time		-	11	-	ns
t <sub>d(off)</sub>	Turn-Off Delay Time		-	110	-	ns
t <sub>f</sub>	Turn-Off Fall Time		-	9	-	ns
Q <sub>g</sub>	Total Gate Charge	V <sub>DS</sub> = 400V, I <sub>D</sub> = 20A V <sub>GS</sub> = 10V (Note 4)	-	30	-	nC
Q <sub>gs</sub>	Gate-Source Charge		-	10	-	nC
Q <sub>gd</sub>	Gate-Drain Charge		-	9	-	nC
<b>Drain-Source Diode Characteristics and Maximum Ratings</b>						
I <sub>S</sub>	Maximum Continuous Drain-Source Diode Forward Current		-	-	24	A
I <sub>SM</sub>	Maximum Pulsed Drain-Source Diode Forward Current		-	-	70	A
V <sub>SD</sub>	Drain-Source Diode Forward Voltage	V <sub>GS</sub> = 0V, I <sub>S</sub> = 12A	-	0.9	1.5	V
t <sub>rr</sub>	Reverse Recovery Time	V <sub>GS</sub> = 0V, I <sub>S</sub> = 20A	-	500	-	ns
Q <sub>rr</sub>	Reverse Recovery Charge	dI <sub>F</sub> /dt = 100A/μs	-	6	-	μC

**NOTES:**

1. Repetitive Rating: Pulse width limited by maximum junction temperature
2. I<sub>AS</sub>=3.5A, V<sub>DD</sub>=50V, Starting T<sub>J</sub>=25 °C
3. I<sub>SD</sub>≤I<sub>D</sub>, di/dt ≤ 200A/μs, V<sub>DD</sub> ≤ BV<sub>DSS</sub>, Starting T<sub>J</sub> = 25 °C
4. Essentially Independent of Operating Temperature Typical Characteristics



# Typical Performance Characteristics

Power dissipation  
TO-220, TO-247, TO-3P

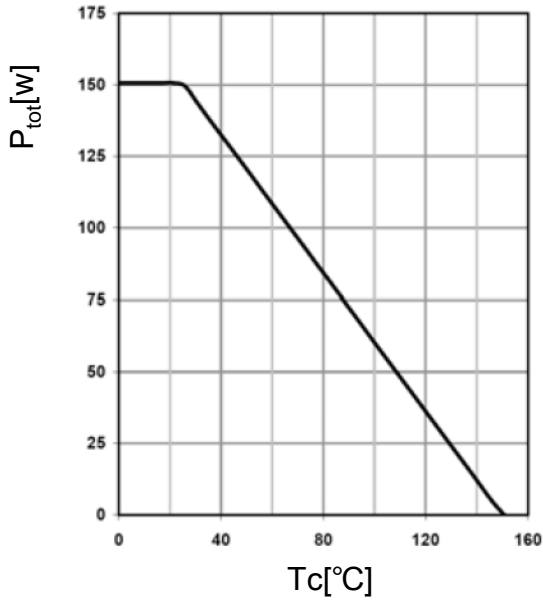

Power dissipation  
TO-220F

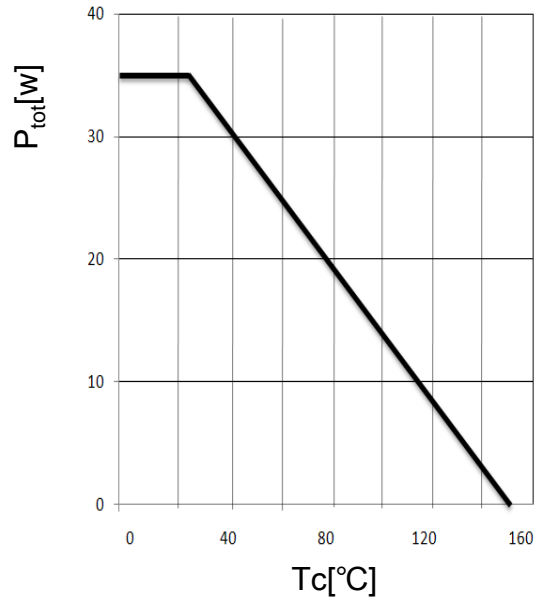

Max. transient thermal impedance  
TO-220, TO-247, TO-3P

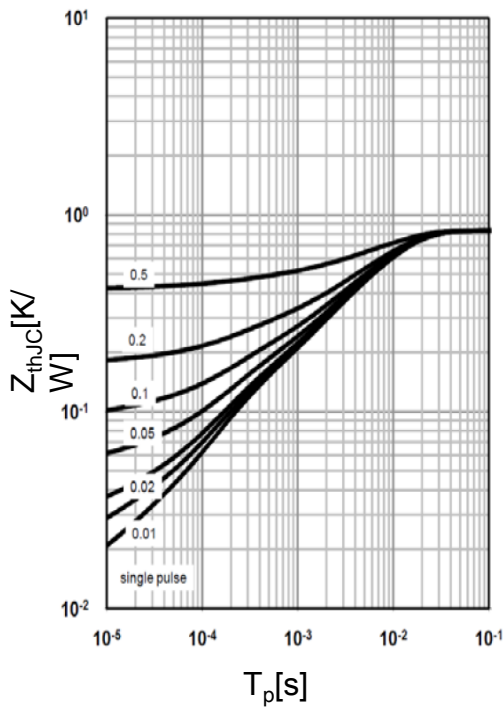

Max. transient thermal impedance  
TO-220F

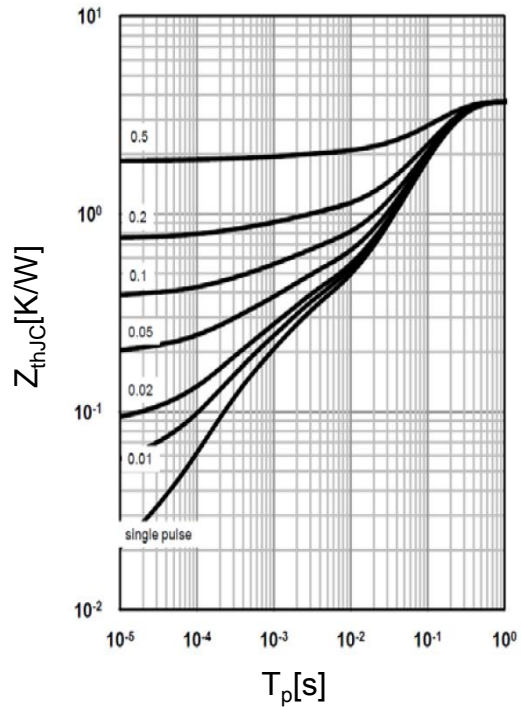



# Typical Performance Characteristics

Safe operating area  $TC=25\text{ }^{\circ}\text{C}$   
TO-220, TO-247, TO-3P

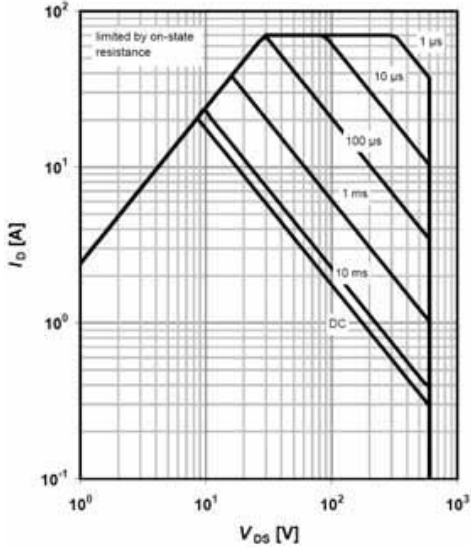

$$I_D=f(V_{DS}); T_C=25\text{ }^{\circ}\text{C}; V_{GS} > 7\text{V}; D=0; \text{parameter } t_p$$

Safe operating area  $TC=25\text{ }^{\circ}\text{C}$   
TO-220F

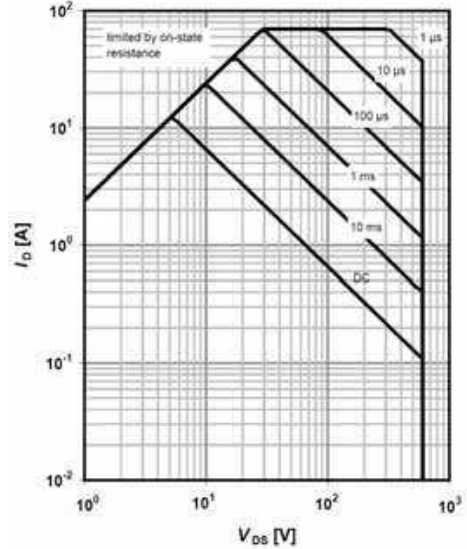

Safe operating area  $TC=80\text{ }^{\circ}\text{C}$   
TO-220, TO-247, TO-3P

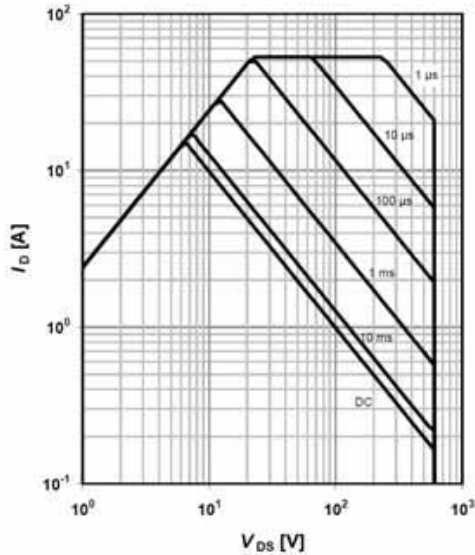

$$I_D=f(V_{DS}); T_C=80\text{ }^{\circ}\text{C}; V_{GS} > 7\text{V}; D=0; \text{parameter } t_p$$

Safe operating area  $TC=80\text{ }^{\circ}\text{C}$   
TO-220F

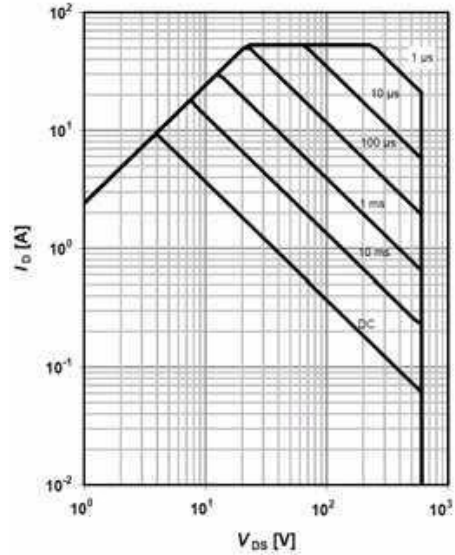



# Typical Performance Characteristics

Typ. output characteristics  
 $T_j=25\text{ }^\circ\text{C}$

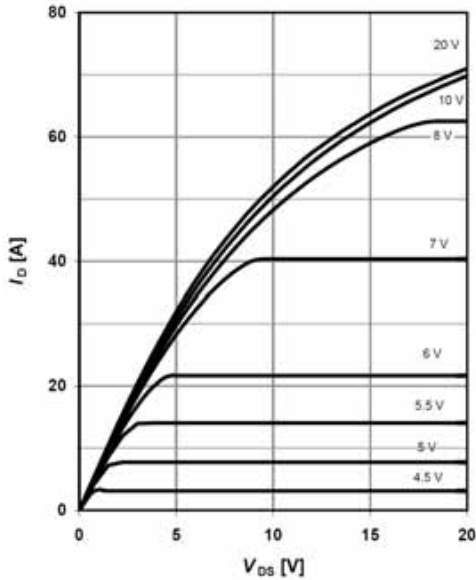

$I_D=f(V_{DS}); T_j=25\text{ }^\circ\text{C}; \text{parameter: } V_{GS}$

Typ. output characteristics  
 $T_j=125\text{ }^\circ\text{C}$

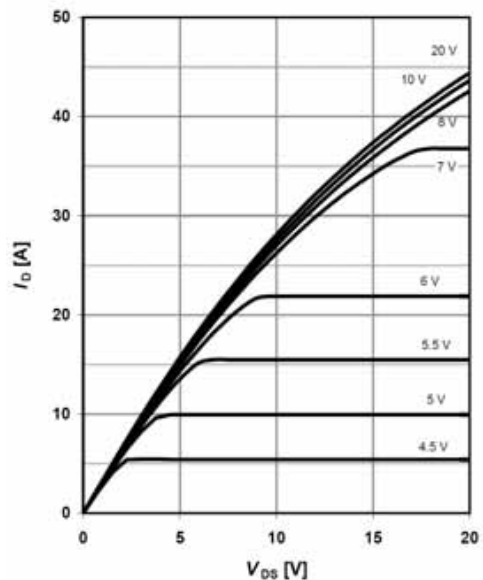

$I_D=f(V_{DS}); T_j=125\text{ }^\circ\text{C}; \text{parameter: } V_{GS}$

Typ. drain-source on-state resistance

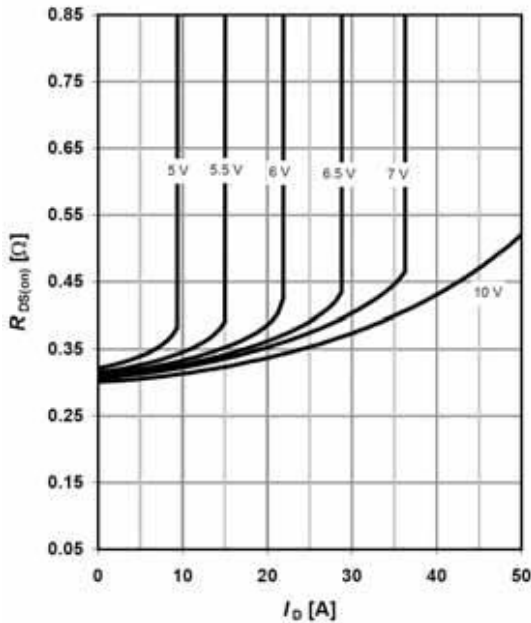

$R_{DS(on)}=f(I_D); T_j=125\text{ }^\circ\text{C}; \text{parameter: } V_{GS}$

Typ. drain-source on-state resistance

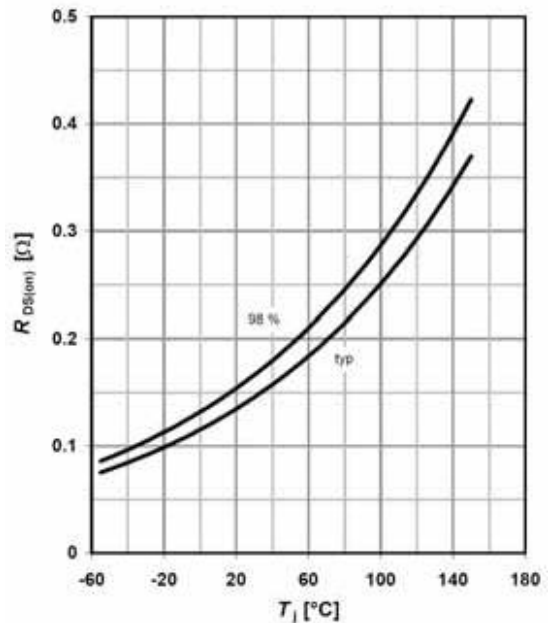

$R_{DS(on)}=f(T_j); I_D=12\text{ A}; V_{GS}=10\text{ V}$



# Typical Performance Characteristics

Typ. transfer characteristics

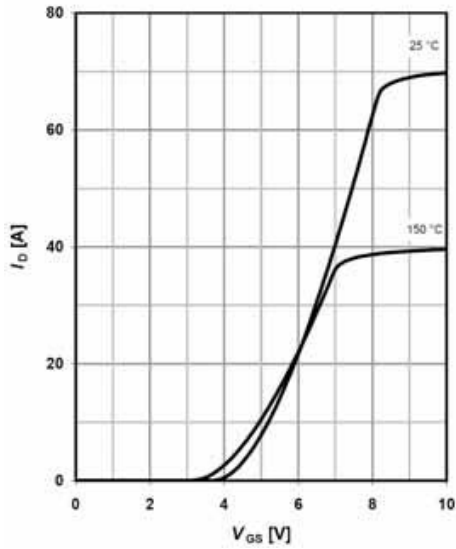

$$I_D = f(V_{GS}); V_{DS} = 40V$$

Typ. gate charge

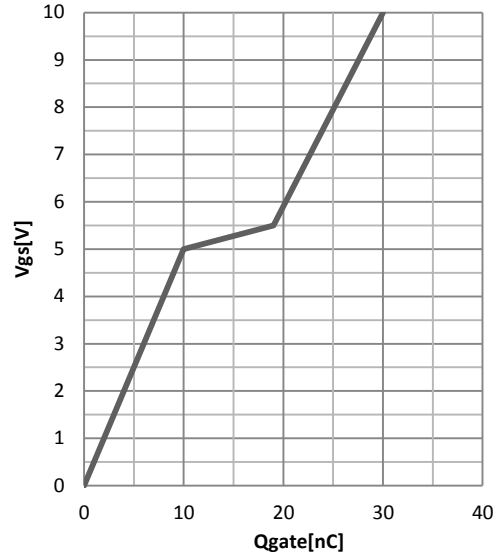

$$V_{GS} = f(Q_g), I_D = 20A \text{ pulsed}$$

Avalanche energy

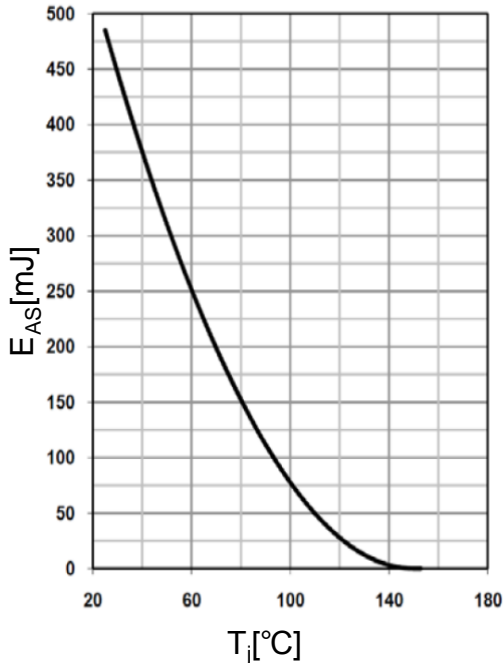

$$E_{AS} = f(T_j); I_D = 3.5A; V_{DD} = 50V$$

Drain-source breakdown voltage

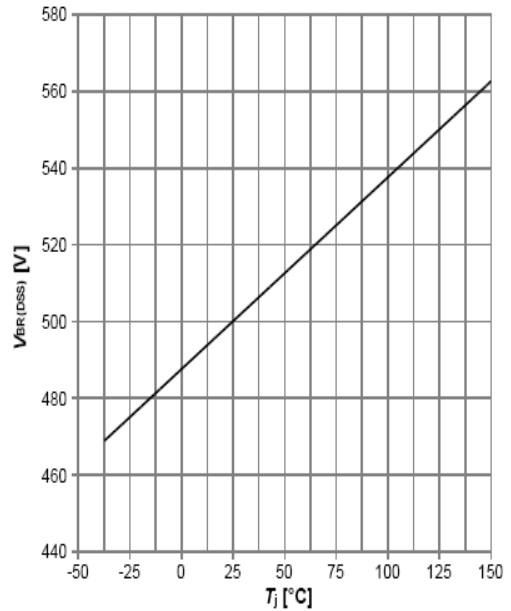

$$V_{BR(DSS)} = f(T_j); I_D = 0.25mA$$



# Typical Performance Characteristics

Typ. capacitances

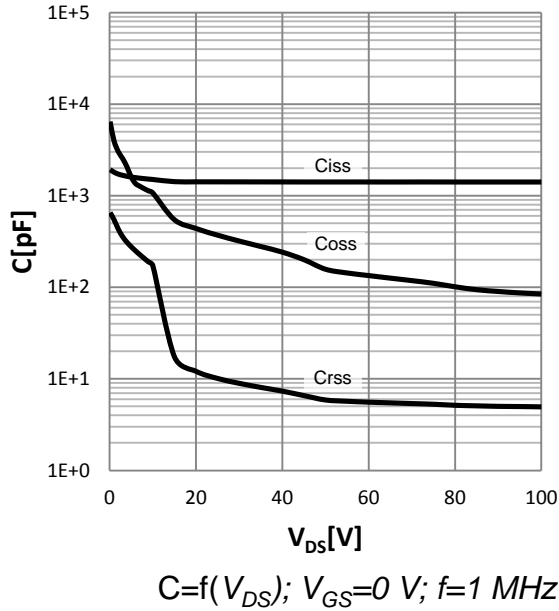

Typ. Coss stored energy

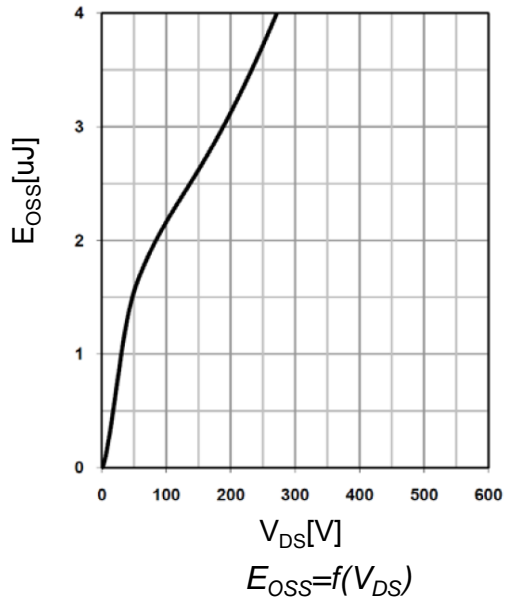

Forward characteristics of reverse diode

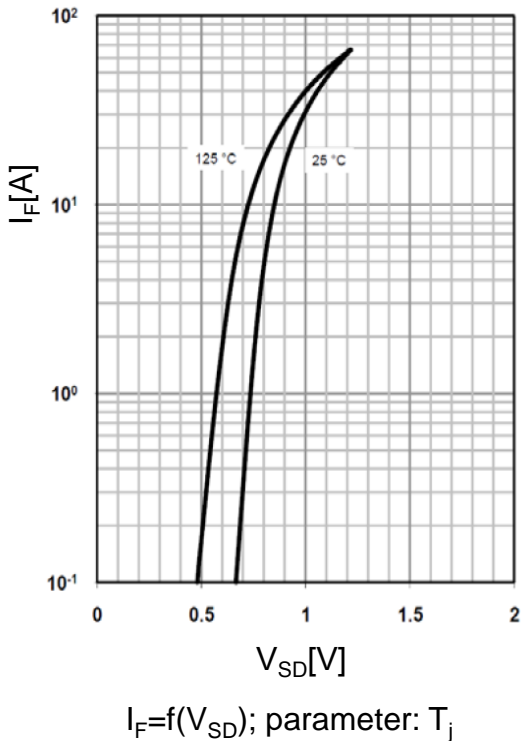



Switching times test circuit and waveform for inductive load

Switching times test circuit for inductive load

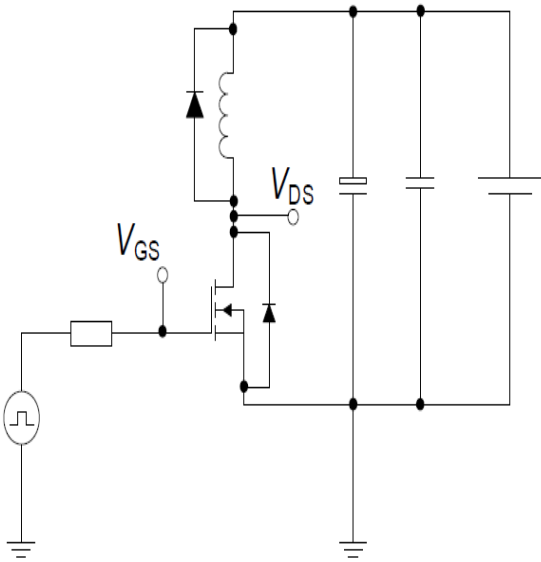

Switching time waveform

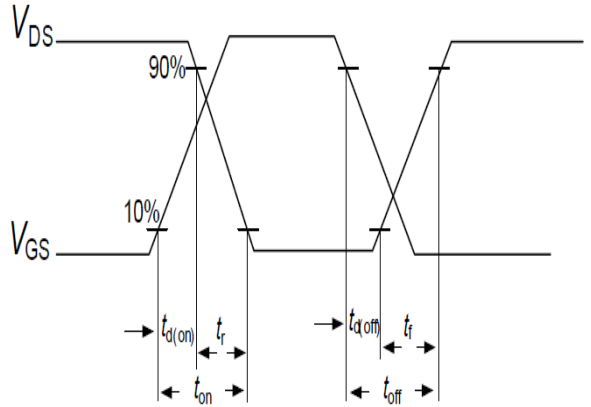

Unclamped inductive load test circuit and waveform

Unclamped inductive load test circuit

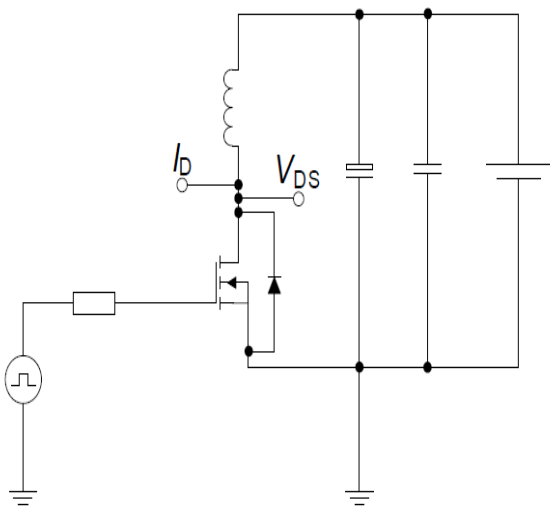

Unclamped inductive waveform

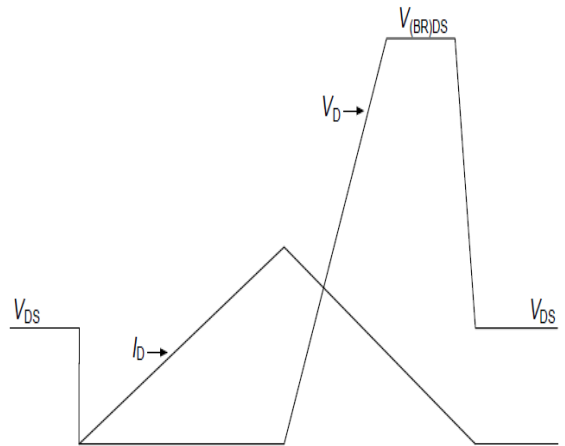



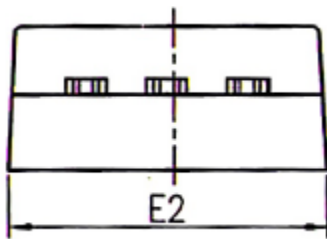
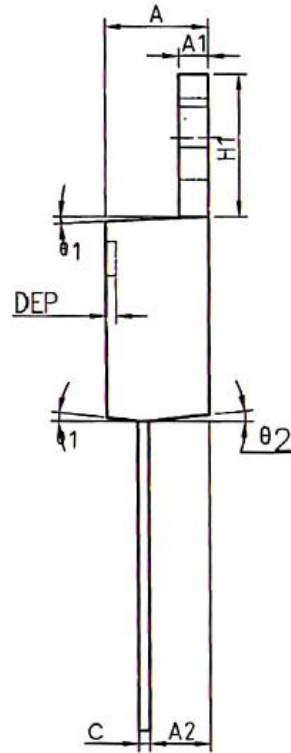
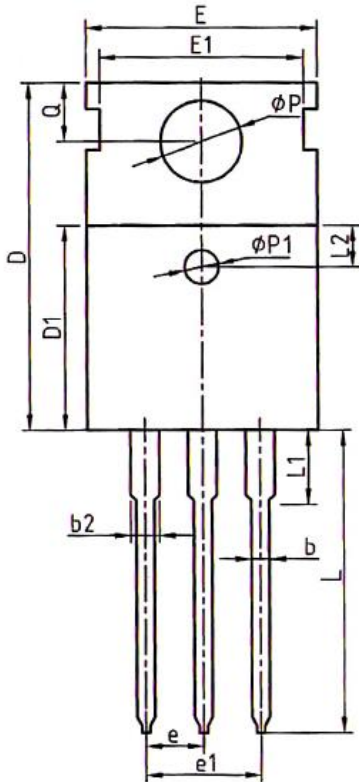

### COMMON DIMENSIONS

SYMBOL	MM		
	MIN	NDM	MAX
A	4.40	4.57	4.70
A1	1.27	1.30	1.37
A2	2.35	2.40	2.50
b	0.77	0.80	0.90
b2	1.17	1.27	1.36
c	0.48	0.50	0.56
D	15.40	15.60	15.80
D1	9.00	9.10	9.20
DEP	0.05	0.10	0.20
E	9.80	10.00	10.20
E1	-	8.70	-
E2	9.80	10.00	10.20
$\phi P1$	1.40	1.50	1.60
e	2.54BSC		
e1	5.08BSC		
H1	6.40	6.50	6.60
L	12.75	13.50	13.65
L1	-	3.10	3.30
L2	2.50REF		
$\phi P$	3.50	3.60	3.63
Q	2.73	2.80	2.87
$\theta 1$	5°	7°	9°
$\theta 2$	1°	3°	5°
$\theta 3$	1°	3°	5°

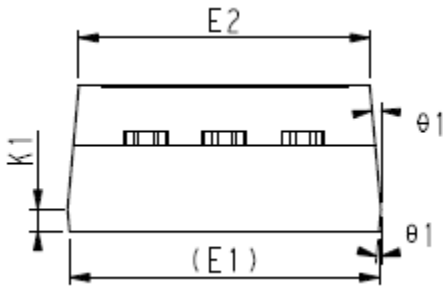
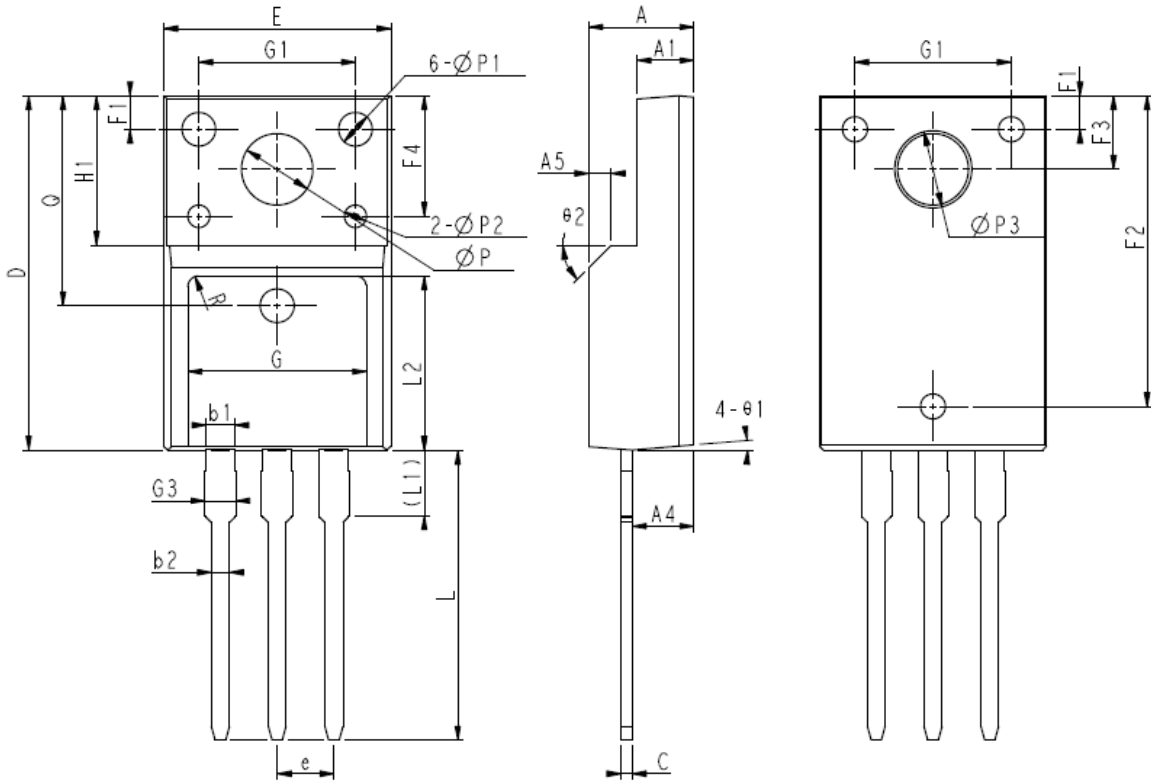

COMMON DIMENSIONS

SYMBOL	MM		
	MIN	NOM	MAX
E	10.00	10.16	10.32
E1	9.94	10.04	10.14
E2	9.36	9.46	9.56
A	4.50	4.70	4.90
A1	2.34	2.54	2.74
A4	2.66	2.76	2.86
A5	1.00REF		
c	0.45	0.50	0.60
D	15.67	15.87	16.07
Q	9.40REF		
H1	6.70REF		
e	2.54BSC		
$\Phi$ P	3.18REF		
L	12.78	12.98	13.18
L1	2.83	2.93	3.03
L2	7.70	7.80	7.90
$\Phi$ P1	1.40	1.50	1.60
$\Phi$ P2	0.95	1.00	1.05
$\Phi$ P3	3.45REF		
$\theta$ 1	3°	5°	7°
$\theta$ 2	-	45°	-
F1	1.00	1.50	2.00
F2	13.80	13.90	14.00
F3	3.20	3.30	3.40
F4	5.30	5.40	5.50
G	7.80	8.00	8.20
G1	6.90	7.00	7.10
G3	1.25	1.35	1.45
b1	1.23	1.28	1.38
b2	0.75	0.80	0.90
K1	0.65	0.70	0.75
R	0.50REF		

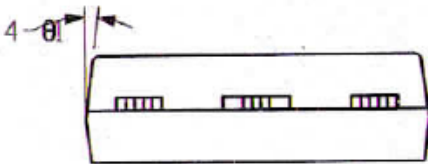
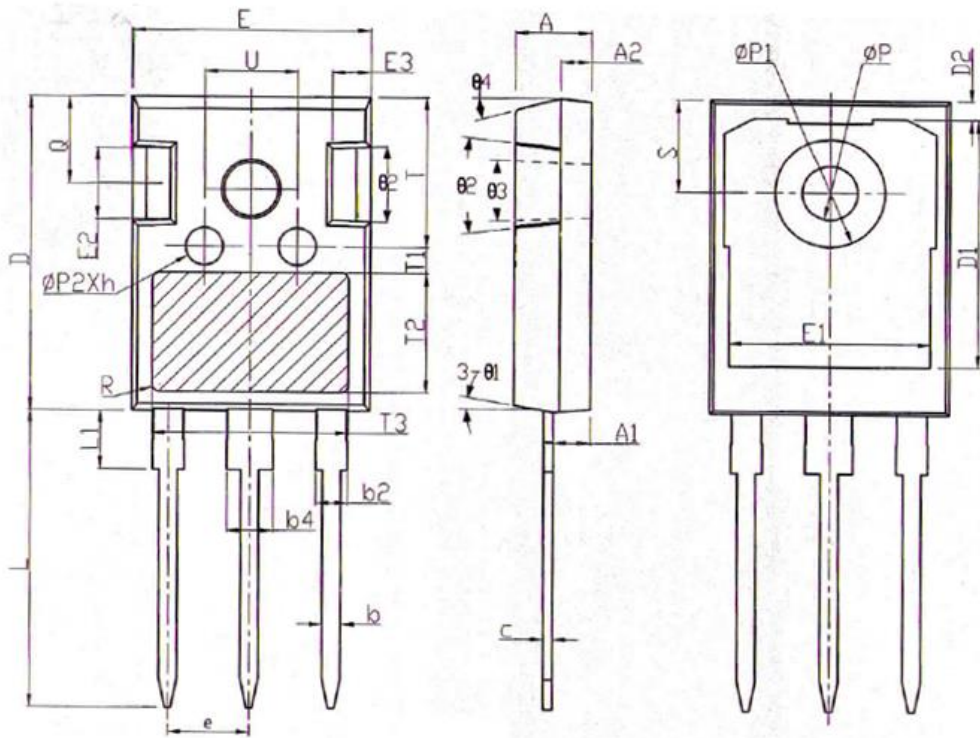

COMMON DIMENSIONS

SYMBOL	MM		
	MIN	NOM	MAX
A	4.90	5.00	5.10
A1	2.31	2.41	2.51
A2	1.90	2.00	2.10
b	1.16	1.21	1.26
b2	1.96	2.01	2.06
b4	2.96	3.01	3.06
c	0.59	0.61	0.66
D	20.90	21.00	21.10
D1	16.25	16.55	16.85
D2	1.05	1.20	1.35
E	15.70	15.80	15.90
E1	13.10	13.30	13.50
E2	4.90	5.00	5.10
E3	2.40	2.50	2.60
e	5.44BSC		
h	0.05	0.10	0.15
L	19.80	19.92	20.10
L1	-	-	4.30
$\Phi P$	3.50	3.60	3.70
$\Phi P1$	-	-	7.30
$\Phi P2$	2.40	2.50	2.60
Q	5.60	5.80	6.00
S	6.15BSC		
R	0.50REF		
T	9.80	-	10.20
T1	1.65REF		
T2	8.00REF		
T3	12.80REF		
U	6.00	-	6.40
$\theta 1$	6°	7°	8°
$\theta 2$	4°	5°	6°
$\theta 3$	1°	-	1.5°
$\theta 4$	14°	15°	16°

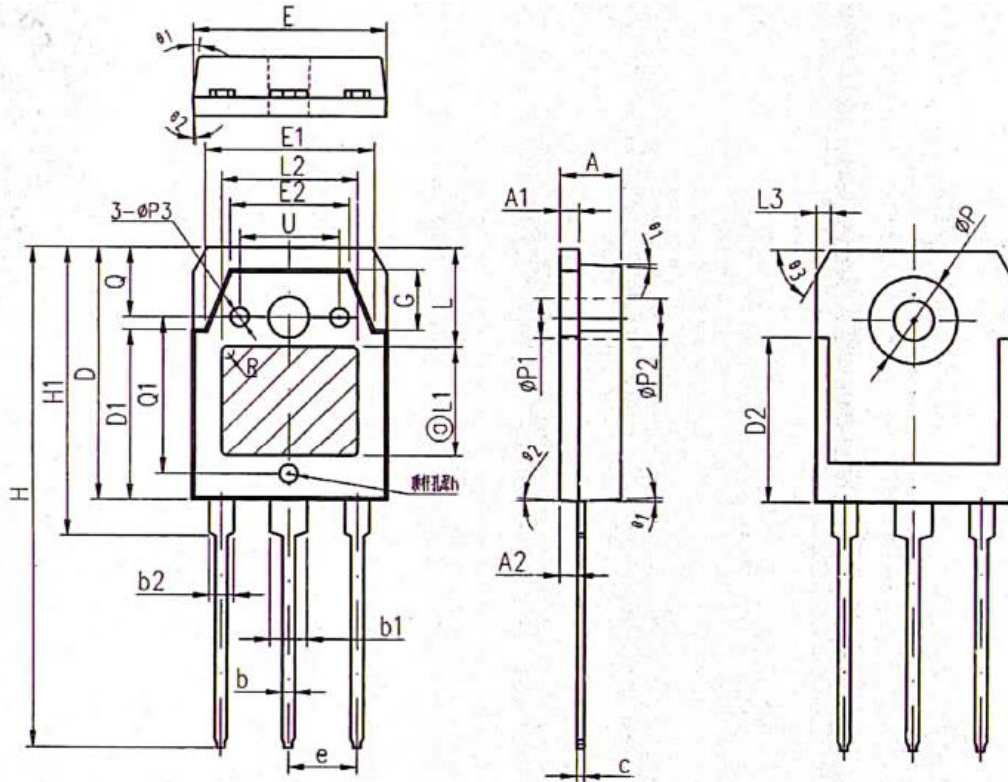

COMMON DIMENSIONS

SYMBOL	MM		
	MIN	NOM	MAX
A	4.60	4.80	5.00
A1	1.40	1.50	1.60
A2	1.33	1.38	1.43
b	0.80	1.00	1.20
b1	2.80	3.00	3.20
b2	1.80	2.00	2.20
c	0.50	0.60	0.70
D	19.75	19.90	20.05
D1	13.70	13.90	14.10
D2	12.90 REF		
E	15.40	15.60	15.80
E1	13.40	13.60	13.80
E2	9.40	9.60	9.80
e	5.45 TYP		
G	4.60	4.80	5.00
H	40.30	40.50	40.70
H1	23.20	23.40	23.60
h	0.05	0.10	0.15
L	7.40 TYP		
L1	9.00 TYP		
L2	11.00 TYP		
L3	1.00 REF		
$\phi P$	6.90	7.00	7.10
$\phi P1$	3.20 REF		
$\phi P2$	3.50 REF		
$\phi P3$	1.40	1.50	1.60
R	0.50 REF		
Q	5.00 REF		
Q1	12.56	12.76	12.96
U	7.8	8	8.2
$\theta 1$	5°	7°	9°
$\theta 2$	1°	3°	5°
$\theta 3$	60° REF		



## DISCLAIMER

SUPER SEMICONDUCTOR reserves the right to make changes WITHOUT further notice to any products herein to improve reliability, function, or design.

For documents and material available from this datasheet, SUPER SEMICONDUCTOR does not warrant or assume any legal liability or responsibility for the accuracy, completeness of any product or technology disclosed hereunder.

The information given in this document shall in no event be regarded as a guarantee of conditions or characteristics. With respect to any examples or hints given herein, any typical values stated herein and/or any information regarding the application of the device, SUPER SEMICONDUCTOR hereby disclaims any and all warranties and liabilities of any kind, including without limitation, warranties of non-infringement of intellectual property rights of any third party.

The products shown herein are not designed for use as critical components in medical, life-saving, or life-sustaining applications, whose failure to perform can be reasonably expected to cause the failure of the life support device or system, or to affect its safety or effectiveness. Customers using or selling SUPER SEMICONDUCTOR products not expressly indicated for use in such applications do so entirely at their own risk and agree to fully indemnify SUPER SEMICONDUCTOR for any damages arising or resulting from such use or sale.

## INFORMATION

For further information on technology, delivery terms and conditions and prices, please contact SUPER SEMICONDUCTOR office or website ([www.supersemi.com.cn](http://www.supersemi.com.cn)).



## X-ON Electronics

Largest Supplier of Electrical and Electronic Components

*Click to view similar products for [MOSFET](#) category:*

*Click to view products by [Super Semiconductor](#) manufacturer:*

Other Similar products are found below :

[614233C](#) [648584F](#) [MCH3443-TL-E](#) [MCH6422-TL-E](#) [FDPF9N50NZ](#) [FW216A-TL-2W](#) [FW231A-TL-E](#) [APT5010JVR](#) [NTNS3A92PZT5G](#)  
[IRF100S201](#) [JANTX2N5237](#) [2SK2464-TL-E](#) [2SK3818-DL-E](#) [FCA20N60\\_F109](#) [FDZ595PZ](#) [STD6600NT4G](#) [FSS804-TL-E](#) [2SJ277-DL-E](#)  
[2SK1691-DL-E](#) [2SK2545\(Q,T\)](#) [D2294UK](#) [405094E](#) [423220D](#) [MCH6646-TL-E](#) [TPCC8103,L1Q\(CM](#) [367-8430-0972-503](#) [VN1206L](#)  
[424134F](#) [026935X](#) [051075F](#) [SBVS138LT1G](#) [614234A](#) [715780A](#) [NTNS3166NZT5G](#) [751625C](#) [873612G](#) [IRF7380TRHR](#)  
[IPS70R2K0CEAKMA1](#) [RJK60S3DPP-E0#T2](#) [RJK60S5DPK-M0#T0](#) [APT5010JVFR](#) [APT12031JFLL](#) [APT12040JVR](#) [DMN3404LQ-7](#)  
[NTE6400](#) [JANTX2N6796U](#) [JANTX2N6784U](#) [JANTXV2N5416U4](#) [SQM110N05-06L-GE3](#) [SIHF35N60E-GE3](#)