

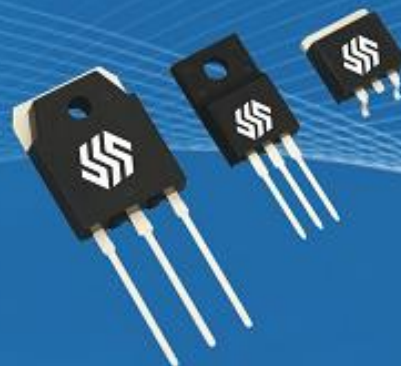

SUPER-SEMI



SUPER-MOSFET

Super Junction Metal Oxide Semiconductor Field Effect Transistor

500V Super Junction Power MOSFET With Fast-Recovery
SS*50R100SFD

Rev.1.0
Sep. 2019

www.supersemi.com.cn

SSW50R100SFD/SSA50R100SFD

500V N-Channel MOSFET With Fast-Recovery

Description

SJ-FET is new generation of high voltage MOSFET family that is utilizing an advanced charge balance mechanism for outstanding low on-resistance and lower gate charge performance.

This advanced technology has been tailored to minimize conduction loss, provide superior switching performance, and withstand extreme dv/dt rate and higher avalanche energy.

SJ-FET is suitable for various AC/DC power conversion in switching mode operation for higher efficiency.

Features

- Multi-Epi process SJ-FET
- Fast-Recovery body diode
- Extremely Low Reverse Recovery Charge
- 550V @T_J = 150 °C
- Typ. R_{DS(on)} = 90mΩ
- Ultra Low Gate Charge (typ. Q_g = 45nC)
- 100% avalanche tested

SSW50R100SFD



SSA50R100SFD

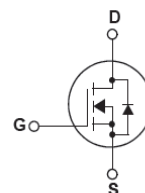
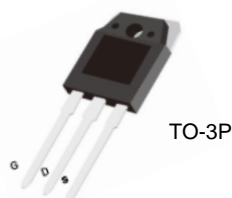

Absolute Maximum Ratings

Symbol	Parameter	SSW_A50R100SFD	Unit
V _{DSS}	Drain-Source Voltage	500	V
I _D	Drain Current -Continuous (TC = 25°C) -Continuous (TC = 100°C)	33* 20*	A
I _{DM}	Drain Current - Pulsed (Note 1)	100	A
V _{GSS}	Gate-Source voltage	±30	V
E _{AS}	Single Pulsed Avalanche Energy (Note 2)	780	mJ
I _{AR}	Repetitive Avalanche Current (Note 1)	9	A
E _{AR}	Repetitive Avalanche Energy (Note 1)	1	mJ
dv/dt	Peak Diode Recovery dv/dt (Note 3)	15	V/ns
dV _{ds} /dt	Drain Source voltage slope (V _{ds} =400V)	50	V/ns
P _D	Power Dissipation (TC = 25°C)	284	W
T _J , T _{STG}	Operating and Storage Temperature Range	-55 to +150	°C
T _L	Maximum Lead Temperature for Soldering Purpose, 1/8" from Case for 5 Seconds	300	°C

* Drain current limited by maximum junction temperature. Maximum duty cycle D=0.75.

Thermal Characteristics

Symbol	Parameter	SSW_A50R100SFD	Unit
R _{θJC}	Thermal Resistance, Junction-to-Case	0.44	°C/W
R _{θCS}	Thermal Resistance, Case-to-Sink Typ.	0.5	°C/W
R _{θJA}	Thermal Resistance, Junction-to-Ambient	62	°C/W



Electrical Characteristics TC = 25°C unless otherwise noted

SSW50R100SFD/SSA50R100SFD 500V N-Channel MOSFET With Fast-Recovery

Symbol	Parameter	Conditions	Min	Typ	Max	Unit
Off Characteristics						
BV _{DSS}	Drain-Source Breakdown Voltage	V _{GS} = 0V, I _D = 250μA, T _J = 25°C	500	-	-	V
		V _{GS} = 0V, I _D = 250μA, T _J = 150°C	-	550	-	V
ΔBV _{DSS} /ΔT _J	Breakdown Voltage Temperature Coefficient	I _D = 250μA, Referenced to 25°C	-	0.6	-	V/°C
I _{DSS}	Zero Gate Voltage Drain Current	V _{DS} = 500V, V _{GS} = 0V -T _J = 150°C	-	1 300	5 -	μA μA
I _{GSSF}	Gate-Body Leakage Current, Forward	V _{GS} = 30V, V _{DS} = 0V	-	-	100	nA
I _{GSSR}	Gate-Body Leakage Current, Reverse	V _{GS} = -30V, V _{DS} = 0V	-	-	-100	nA
On Characteristics						
V _{GS(th)}	Gate Threshold Voltage	V _{DS} = V _{GS} , I _D = 250μA	3.0	-	5.0	V
R _{DS(on)}	Static Drain-Source On-Resistance	V _{GS} = 10V, I _D = 17A	-	90	105	mΩ
g _{FS}	Forward Transconductance	V _{DS} = 40V, I _D = 17A	-	25	-	S
Dynamic Characteristics						
C _{iss}	Input Capacitance	V _{DS} = 25V, V _{GS} = 0V, f = 1.0MHz	-	2100	-	pF
C _{oss}	Output Capacitance		-	850	-	pF
C _{rss}	Reverse Transfer Capacitance		-	13	-	pF
Switching Characteristics						
t _{d(on)}	Turn-On Delay Time	V _{DD} = 400V, I _D = 17A R _G = 20Ω (Note 4)	-	42	-	ns
t _r	Turn-On Rise Time		-	9	-	ns
t _{d(off)}	Turn-Off Delay Time		-	150	-	ns
t _f	Turn-Off Fall Time		-	9	-	ns
Q _g	Total Gate Charge	V _{DS} = 400V, I _D = 17A V _{GS} = 10V (Note 4)	-	45	-	nC
Q _{gs}	Gate-Source Charge		-	10.5	-	nC
Q _{gd}	Gate-Drain Charge		-	16.5	-	nC
Drain-Source Diode Characteristics and Maximum Ratings						
I _S	Maximum Continuous Drain-Source Diode Forward Current		-	-	33	A
I _{SM}	Maximum Pulsed Drain-Source Diode Forward Current		-	-	100	A
V _{SD}	Drain-Source Diode Forward Voltage	V _{GS} = 0V, I _S = 17A	-	0.9	1.5	V
t _{rr}	Reverse Recovery Time	V _{GS} = 0V, V _R = 400V, I _S = 15A, di/dt = 100A/μs	-	220	-	ns
Q _{rr}	Reverse Recovery Charge		-	1.6	-	μC
I _{rrm}	Peak Reverse Recovery Current		-	14	-	A

NOTES:

1. Repetitive Rating: Pulse width limited by maximum junction temperature
2. I_{AS} = 9A, V_{DD} = 50V, Starting T_J = 25 °C
3. I_{SD} ≤ I_D, di/dt ≤ 200A/μs, V_{DD} ≤ BV_{DSS}, Starting T_J = 25 °C
4. Essentially Independent of Operating Temperature Typical Characteristics

Typical Performance Characteristics

Power dissipation

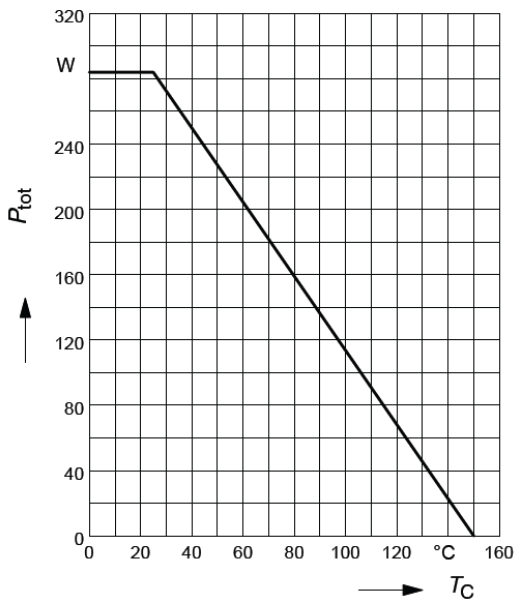

$$P_{tot} = f(T_C)$$

Safe operating area TC=25 °C

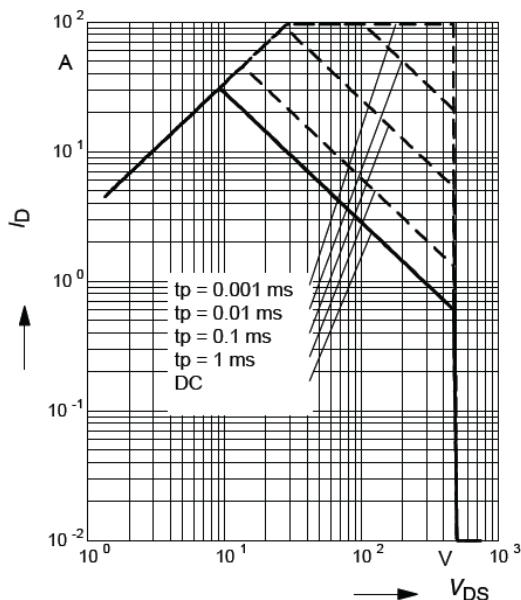

$$I_D = f(V_{DS}); T_C = 25^\circ\text{C}; D = 0; \text{parameter } t_p$$

Max. transient thermal impedance

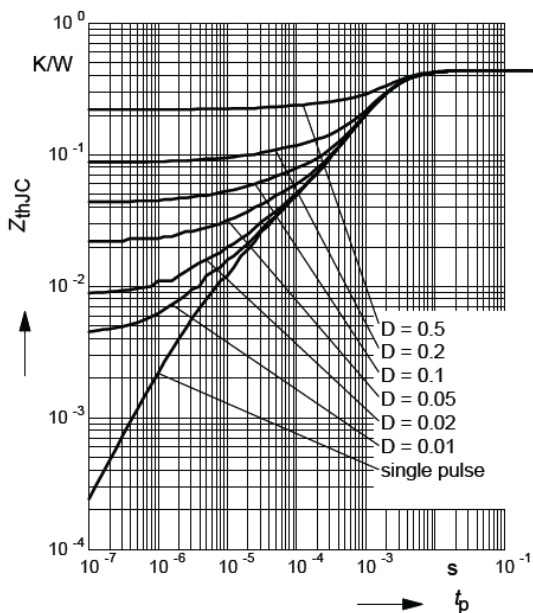

$$Z_{(th)JC} = f(t_p); \text{parameter } D = t_p/T$$

Typ. output characteristics $T_j = 25^\circ\text{C}$

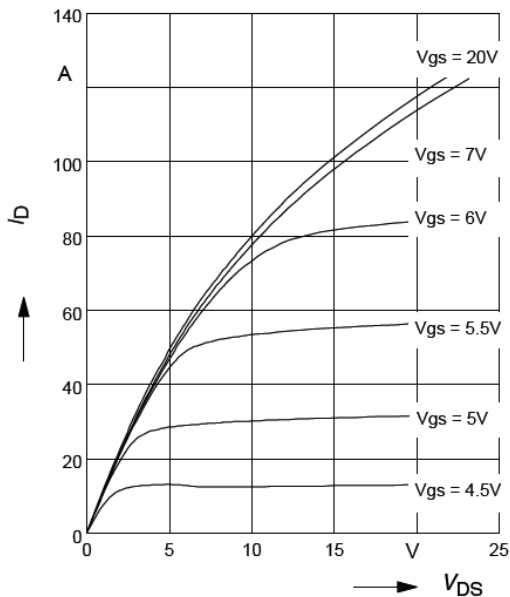

$$I_D = f(V_{DS}); T_j = 25^\circ\text{C}; t_p = 10\mu\text{s}$$

parameter: V_{GS}



Typical Performance Characteristics

Typ. output characteristics $T_j=125\text{ }^\circ\text{C}$

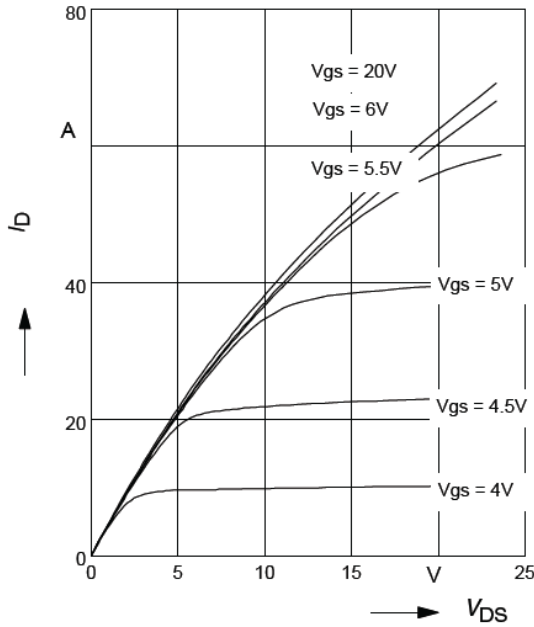

$I_D=f(V_{DS}); T_j=125\text{ }^\circ\text{C}; t_p=10\mu\text{s}$
parameter: V_{GS}

Typ. drain-source on-state resistance

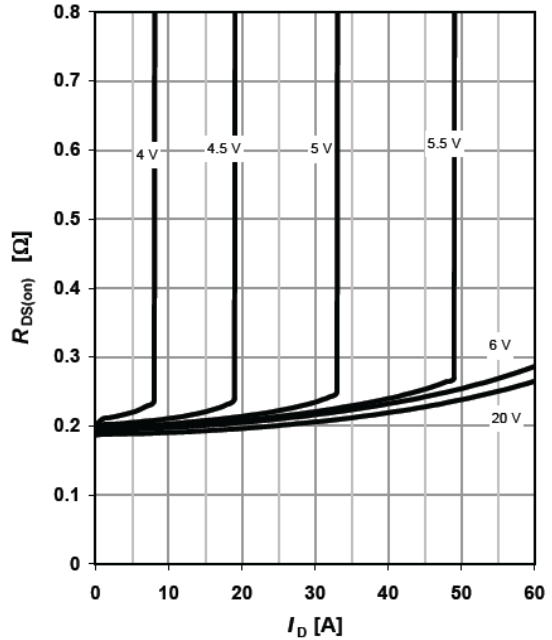

$R_{DS(on)}=f(I_D); T_j=125\text{ }^\circ\text{C};$ parameter: V_{GS}

Typ. drain-source on-state resistance

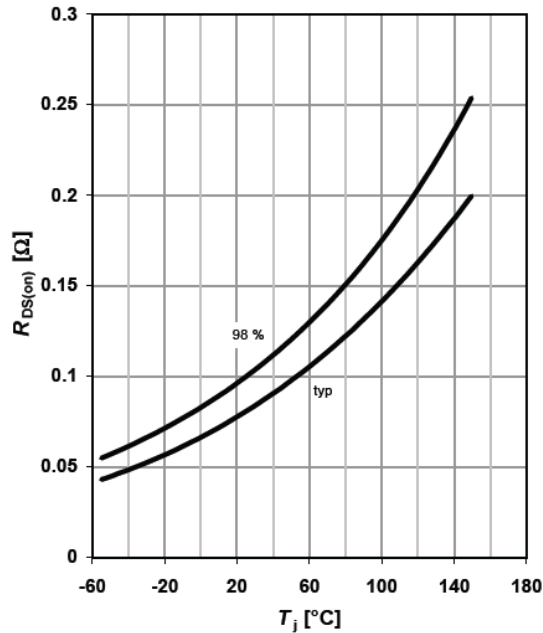

$R_{DS(on)}=f(T_j); I_D=17\text{ A}; V_{GS}=10\text{ V}$

Typ. transfer characteristics

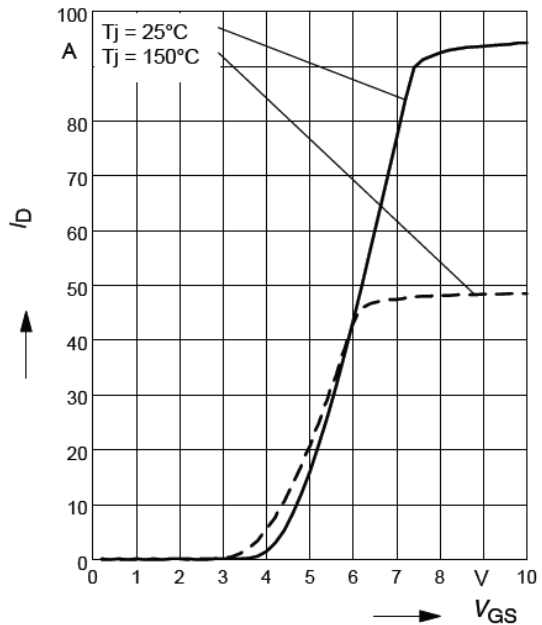

$I_D=f(V_{GS}); V_{DS}=40\text{ V}; t_p=10\mu\text{s}$

Typical Performance Characteristics

Typ. gate charge

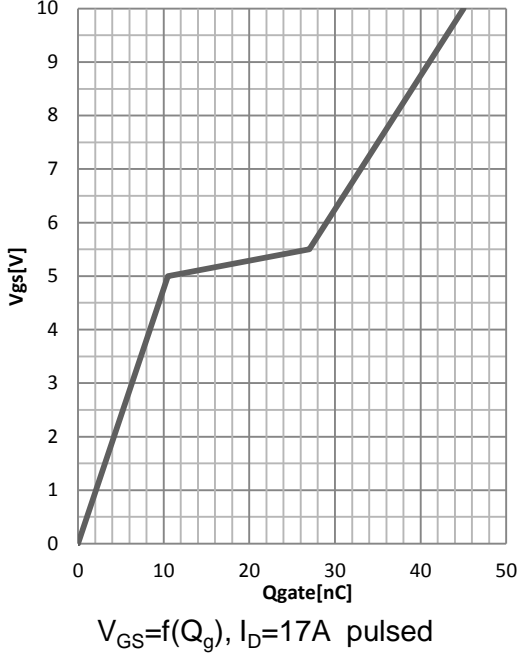

Avalanche energy

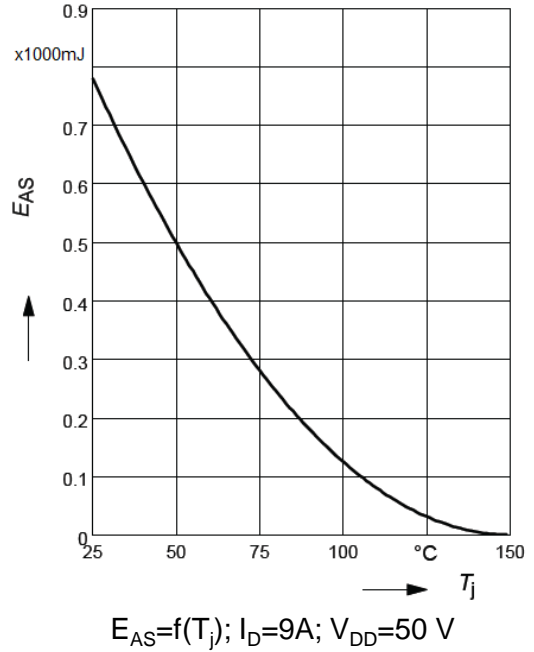

Forward characteristics of reverse diode

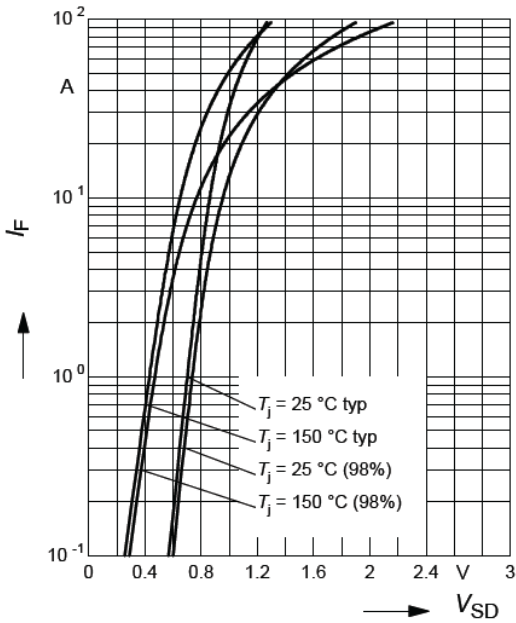

Drain-source breakdown voltage

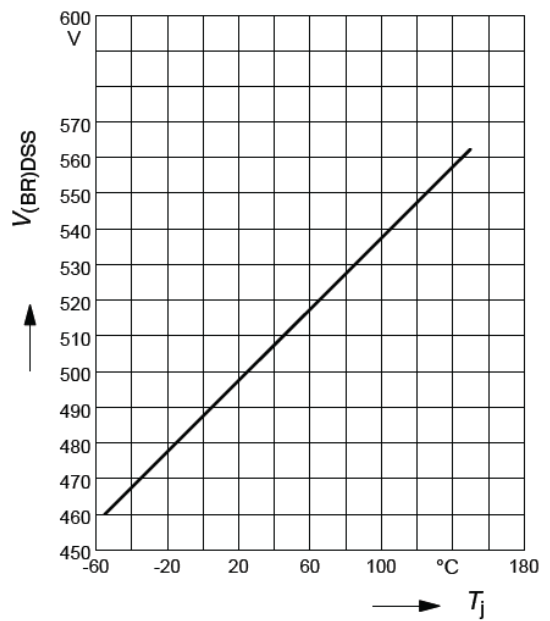



Typical Performance Characteristics

Typ. capacitances

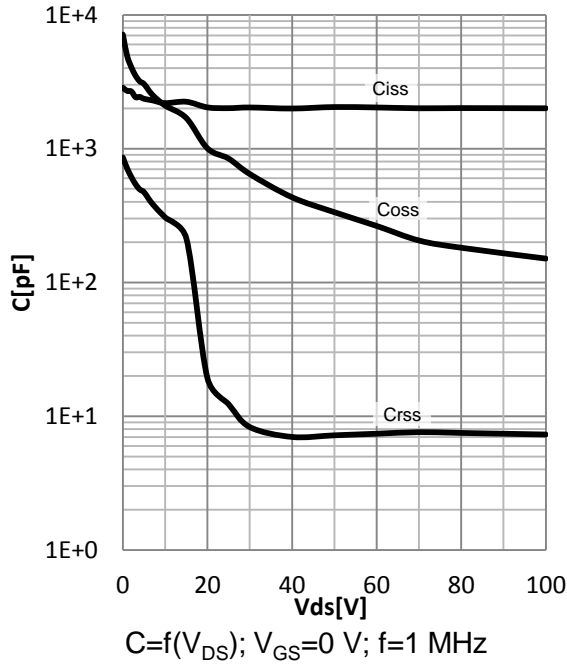

Typ. Coss stored energy

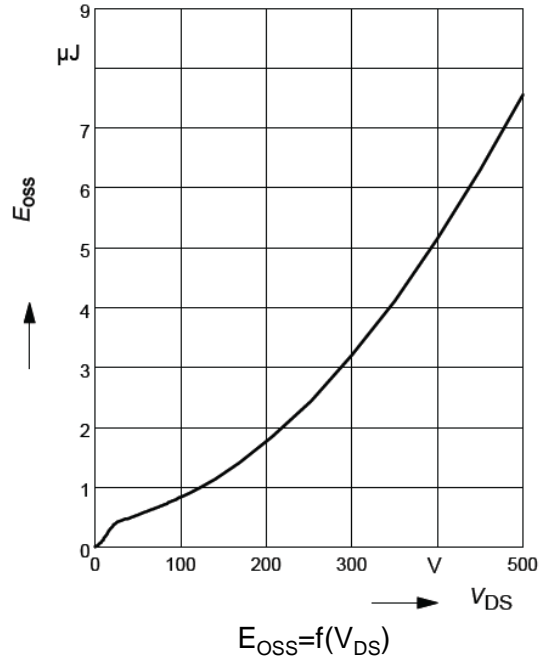

Switching times test circuit and waveform for inductive load

Switching times test circuit for inductive load

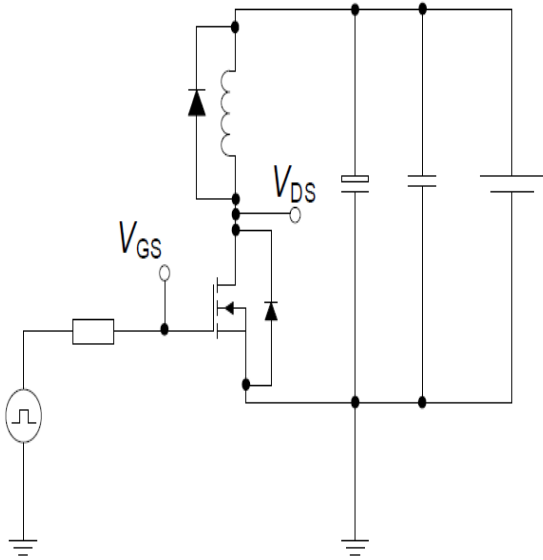

Switching time waveform

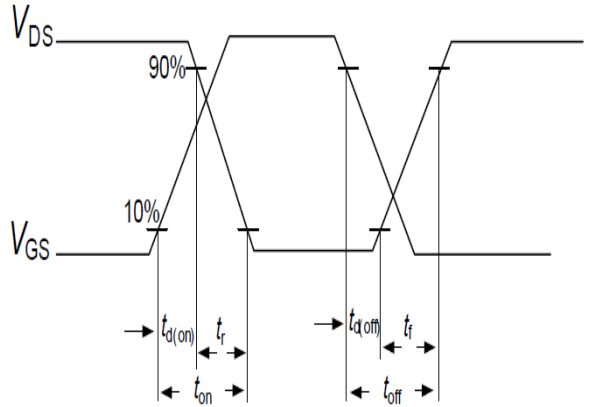

Unclamped inductive load test circuit and waveform

Unclamped inductive load test circuit

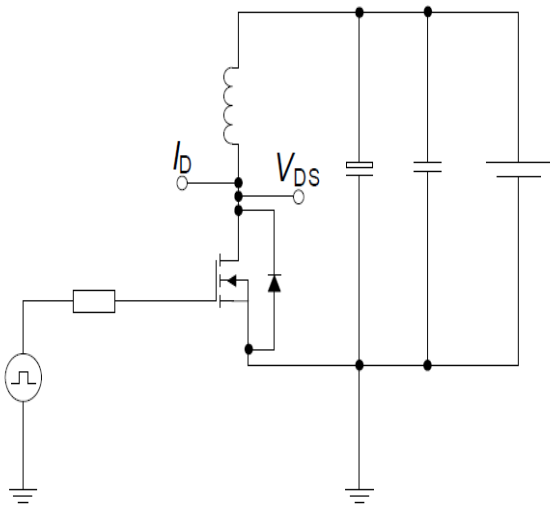

Unclamped inductive waveform

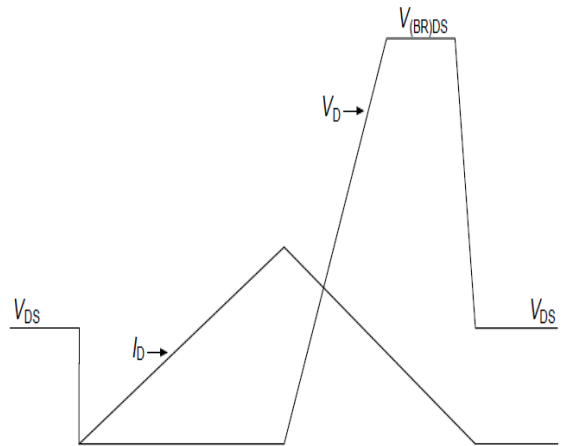

Test circuit and waveform for diode characteristics

Test circuit for diode characteristics

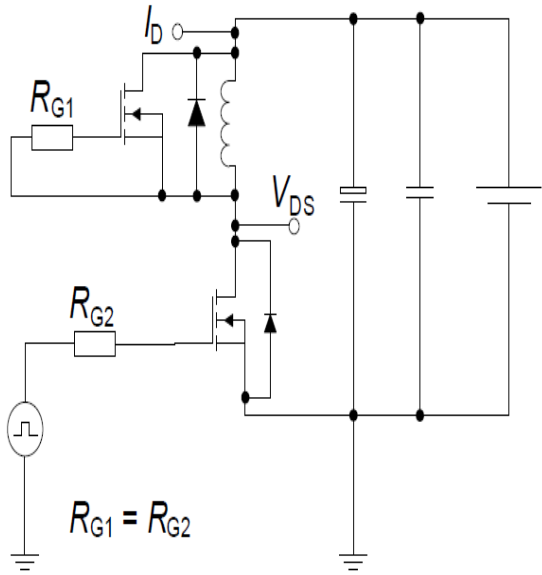

Diode recovery waveform

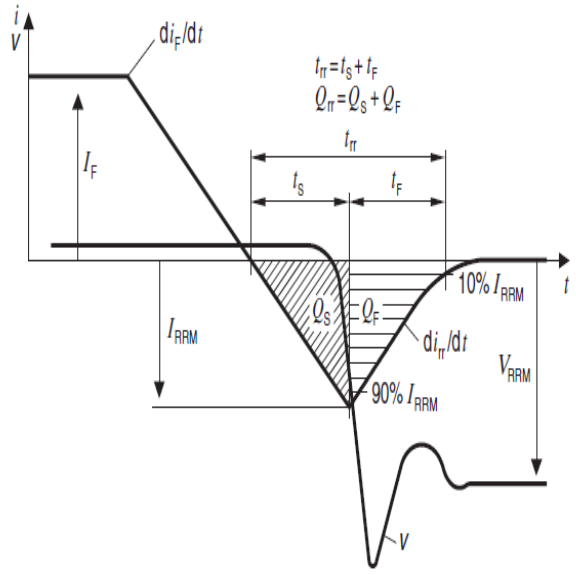

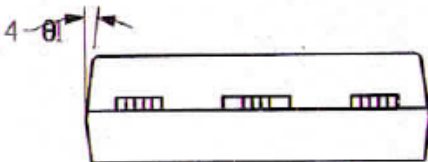
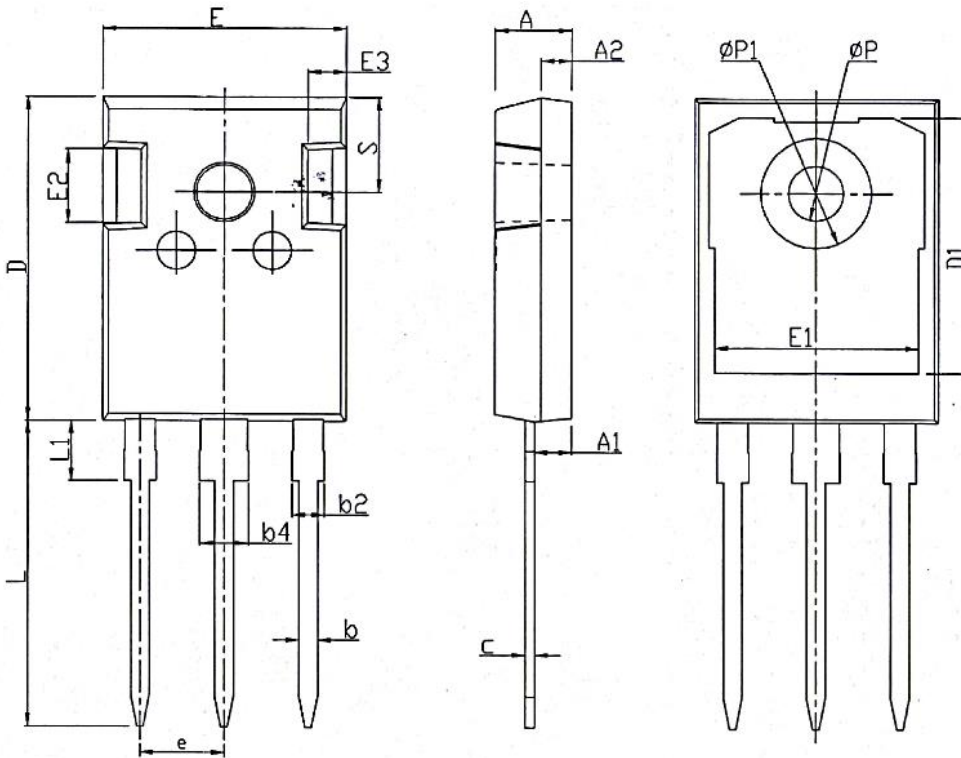

COMMON DIMENSIONS

SYMBOL	MM		
	MIN	NOM	MAX
A	4.90	5.00	5.10
A1	2.31	2.41	2.51
A2	1.90	2.00	2.10
b	1.16	1.21	1.26
b2	1.96	2.01	2.06
b4	2.96	3.01	3.06
c	0.59	0.61	0.66
D	20.90	21.00	21.10
D1	16.25	16.55	16.85
D2	1.05	1.20	1.35
E	15.70	15.80	15.90
E1	13.10	13.30	13.50
E2	4.90	5.00	5.10
E3	2.40	2.50	2.60
e	5.44BSC		
h	0.05	0.10	0.15
L	19.80	19.92	20.10
L1	-	-	4.30
ΦP	3.50	3.60	3.70
$\Phi P1$	-	-	7.30
$\Phi P2$	2.40	2.50	2.60
Q	5.60	5.80	6.00
S	6.15BSC		
R	0.50REF		
T	9.80	-	10.20
T1	1.65REF		
T2	8.00REF		
T3	12.80REF		
U	6.00	-	6.40
$\theta 1$	6°	7°	8°
$\theta 2$	4°	5°	6°
$\theta 3$	1°	-	1.5°
$\theta 4$	14°	15°	16°

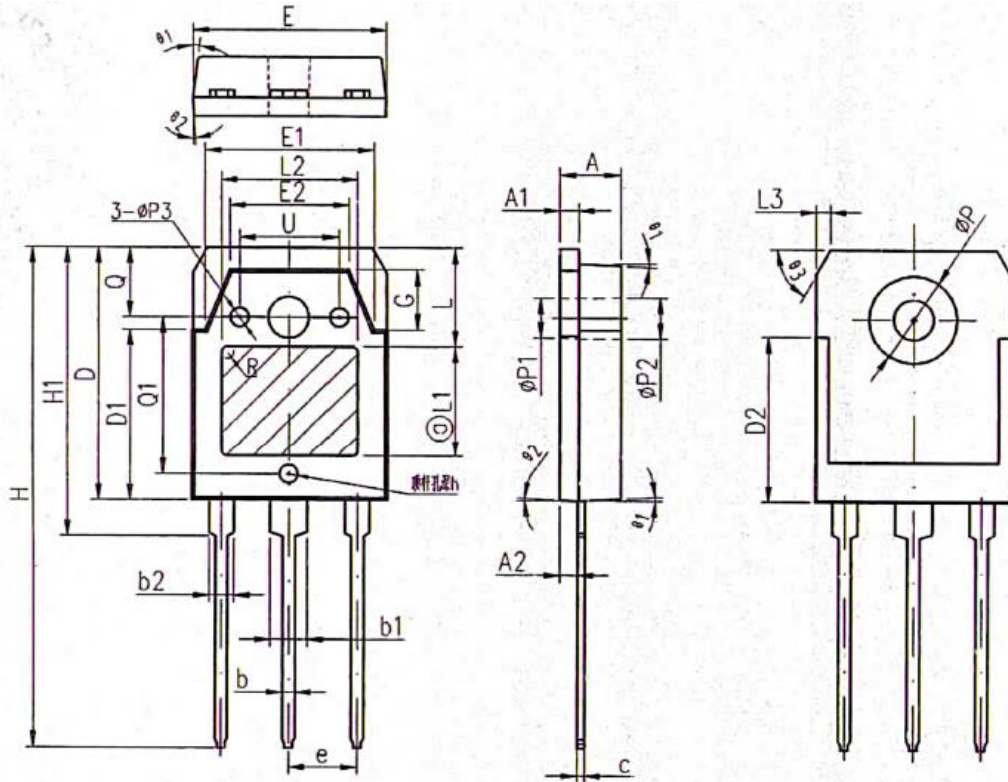

COMMON DIMENSIONS

SYMBOL	MM		
	MIN	NOM	MAX
A	4.60	4.80	5.00
A1	1.40	1.50	1.60
A2	1.33	1.38	1.43
b	0.80	1.00	1.20
b1	2.80	3.00	3.20
b2	1.80	2.00	2.20
c	0.50	0.60	0.70
D	19.75	19.90	20.05
D1	13.70	13.90	14.10
D2	12.90 REF		
E	15.40	15.60	15.80
E1	13.40	13.60	13.80
E2	9.40	9.60	9.80
e	5.45 TYP		
G	4.60	4.80	5.00
H	40.30	40.50	40.70
H1	23.20	23.40	23.60
h	0.05	0.10	0.15
L	7.40 TYP		
L1	9.00 TYP		
L2	11.00 TYP		
L3	1.00 REF		
ϕP	6.90	7.00	7.10
$\phi P1$	3.20 REF		
$\phi P2$	3.50 REF		
$\phi P3$	1.40	1.50	1.60
R	0.50 REF		
Q	5.00 REF		
Q1	12.56	12.76	12.96
U	7.8	8	8.2
$\theta 1$	5°	7°	9°
$\theta 2$	1°	3°	5°
$\theta 3$	60° REF		



DISCLAIMER

SUPER SEMICONDUCTOR reserves the right to make changes WITHOUT further notice to any products herein to improve reliability, function, or design.

For documents and material available from this datasheet, SUPER SEMICONDUCTOR does not warrant or assume any legal liability or responsibility for the accuracy, completeness of any product or technology disclosed hereunder.

The information given in this document shall in no event be regarded as a guarantee of conditions or characteristics. With respect to any examples or hints given herein, any typical values stated herein and/or any information regarding the application of the device, SUPER SEMICONDUCTOR hereby disclaims any and all warranties and liabilities of any kind, including without limitation, warranties of non-infringement of intellectual property rights of any third party.

The products shown herein are not designed for use as critical components in medical, life-saving, or life-sustaining applications, whose failure to perform can be reasonably expected to cause the failure of the life support device or system, or to affect its safety or effectiveness. Customers using or selling SUPER SEMICONDUCTOR products not expressly indicated for use in such applications do so entirely at their own risk and agree to fully indemnify SUPER SEMICONDUCTOR for any damages arising or resulting from such use or sale.

INFORMATION

For further information on technology, delivery terms and conditions and prices, please contact SUPER SEMICONDUCTOR office or website (www.supersemi.com.cn).

X-ON Electronics

Largest Supplier of Electrical and Electronic Components

Click to view similar products for [MOSFET](#) category:

Click to view products by [Super Semiconductor](#) manufacturer:

Other Similar products are found below :

[614233C](#) [648584F](#) [MCH3443-TL-E](#) [MCH6422-TL-E](#) [FDPF9N50NZ](#) [FW216A-TL-2W](#) [FW231A-TL-E](#) [APT5010JVR](#) [NTNS3A92PZT5G](#)
[IRF100S201](#) [JANTX2N5237](#) [2SK2464-TL-E](#) [2SK3818-DL-E](#) [FCA20N60_F109](#) [FDZ595PZ](#) [STD6600NT4G](#) [FSS804-TL-E](#) [2SJ277-DL-E](#)
[2SK1691-DL-E](#) [2SK2545\(Q,T\)](#) [D2294UK](#) [405094E](#) [423220D](#) [MCH6646-TL-E](#) [TPCC8103,L1Q\(CM](#) [367-8430-0972-503](#) [VN1206L](#)
[424134F](#) [026935X](#) [051075F](#) [SBVS138LT1G](#) [614234A](#) [715780A](#) [NTNS3166NZT5G](#) [751625C](#) [873612G](#) [IRF7380TRHR](#)
[IPS70R2K0CEAKMA1](#) [RJK60S3DPP-E0#T2](#) [RJK60S5DPK-M0#T0](#) [APT5010JVFR](#) [APT12031JFLL](#) [APT12040JVR](#) [DMN3404LQ-7](#)
[NTE6400](#) [JANTX2N6796U](#) [JANTX2N6784U](#) [JANTXV2N5416U4](#) [SQM110N05-06L-GE3](#) [SIHF35N60E-GE3](#)