

Simple 90V, 25mA, Temperature Compensated, Constant Current, LED Driver IC

Features

- ▶ 5.0 - 90V operating range (V_{A-B})
- ▶ 25mA \pm 10% at 5.0 - 90V
- ▶ 0.01%/°C typical temperature coefficient
- ▶ No external components (two terminal device)
- ▶ Can be paralleled for higher current

Applications

- ▶ LED channel lighting
- ▶ Industrial lamp indicators
- ▶ Accent lighting

General Description

The Supertex CL25 is a high voltage, temperature compensated, constant current source. The device is trimmed to provide a constant current of 25mA \pm 10% at an input voltage of 5.0 - 90V. No external components are required. The device can be used as a two terminal constant current source or constant current sink.

A typical application for the CL25 is to drive LEDs with a constant current of 25mA. Multiple CL2s can also be used in parallel to provide higher currents such as 50mA, 75mA or 100mA. The device is available in TO-92 and TO-243AA (SOT-89) packaging.

Typical Application Circuit

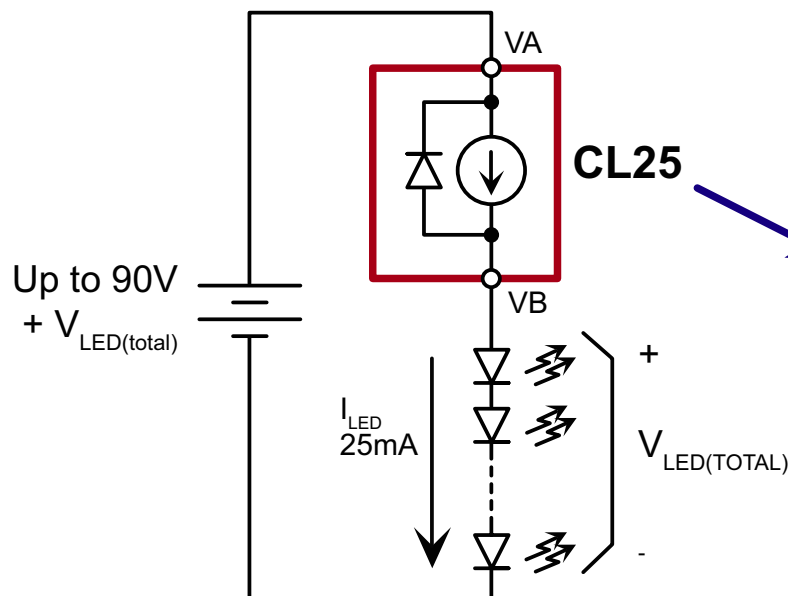

Functional Circuit Diagram

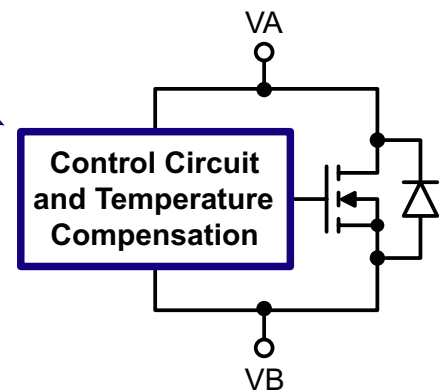

Ordering Information

Device	Package Options	
	TO-92	TO-243AA (SOT-89)
CL25	CL25N3-G	CL25N8-G

-G indicates package is RoHS compliant ('Green')



Pin Configuration

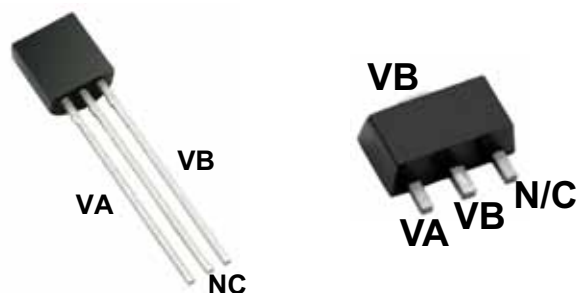

TO-92 (N3)

TO-243AA (SOT-89) (N8)

NC = No Connect

Thermal Characteristics

Package	Power Dissipation @ $T_A = 25^\circ\text{C}$ (W)	θ_{JC} ($^\circ\text{C}/\text{W}$)	θ_{JA} ($^\circ\text{C}/\text{W}$)
TO-92	0.6	125	170
TO-243AA (SOT-89)	1.3*	15	78*

* Mounted on FR4 board; 25mm x 25mm x 1.57mm

Absolute Maximum Ratings

Parameter	Value
Operating voltage, V_{A-B}	100V
Operating junction temperature, T_J	-40 $^\circ\text{C}$ to +125 $^\circ\text{C}$
Storage temperature, T_S	-55 $^\circ\text{C}$ to +150 $^\circ\text{C}$

Absolute Maximum Ratings are those values beyond which damage to the device may occur. Functional operation under these conditions is not implied. Continuous operation of the device at the absolute rating level may affect device reliability. All voltages are referenced to device ground.

Electrical Characteristics

($T_A = 25^\circ\text{C}$ unless otherwise specified)

Sym	Parameter	Min	Typ	Max	Units	Conditions
V_{A-B}	Operating voltage	5.0	-	90	V	---
I_{A-B}	Current regulation	22.5	25	27.5	mA	$V_{A-B} = 5.0\text{V} - 90\text{V}$
$\Delta I_{A-B}/\Delta T$	I_{A-B} temperature coefficient	-	0.01	-	%/ $^\circ\text{C}$	$V_{A-B} = 45\text{V}$, $T_J = -40^\circ\text{C}$ to +100 $^\circ\text{C}$
T_J	Operating junction temperature	-40	-	125	$^\circ\text{C}$	---
R_{A-B}	Dynamic resistance	-	300	-	k Ω	---

Product Marking



YY = Year Sealed
WW = Week Sealed
— = "Green" Packaging

Package may or may not include the following marks: Si or

TO-92 (N3)

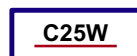

W = Code for week sealed
— = "Green" Packaging

Package may or may not include the following marks: Si or

TO-243AA (SOT-89) (N8)

Functional Circuit Diagram

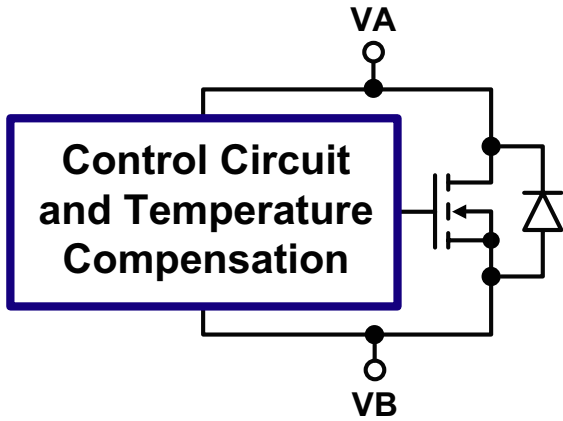

Equivalent Block Diagram

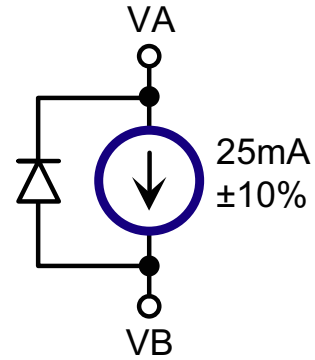

Temperature Characteristics

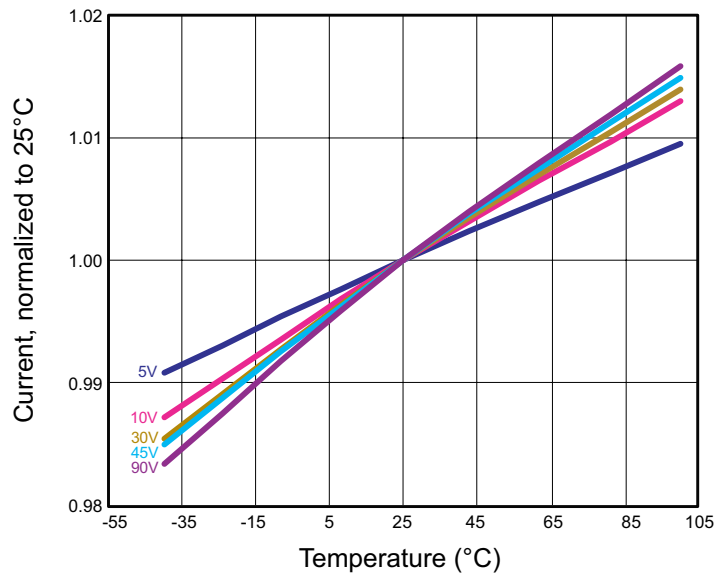

Output Current vs Voltage

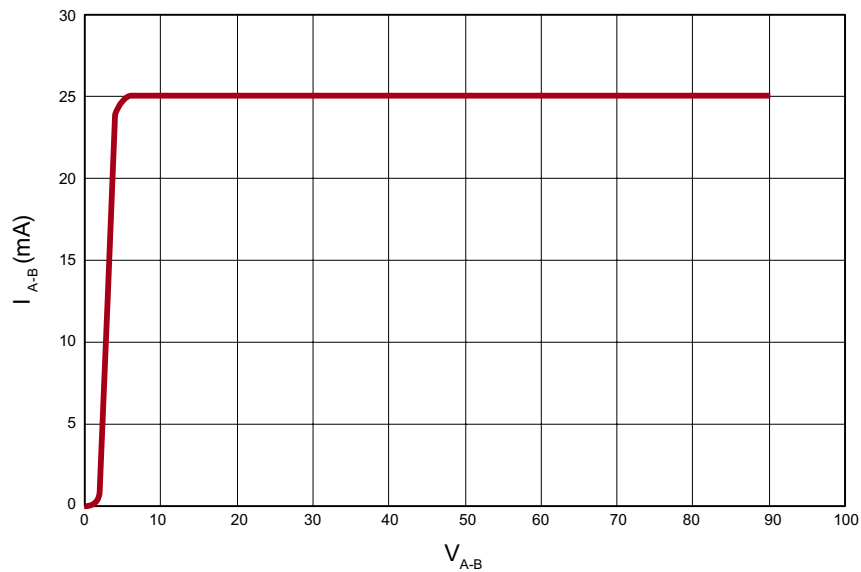

CL25 for Multiple LED Strings

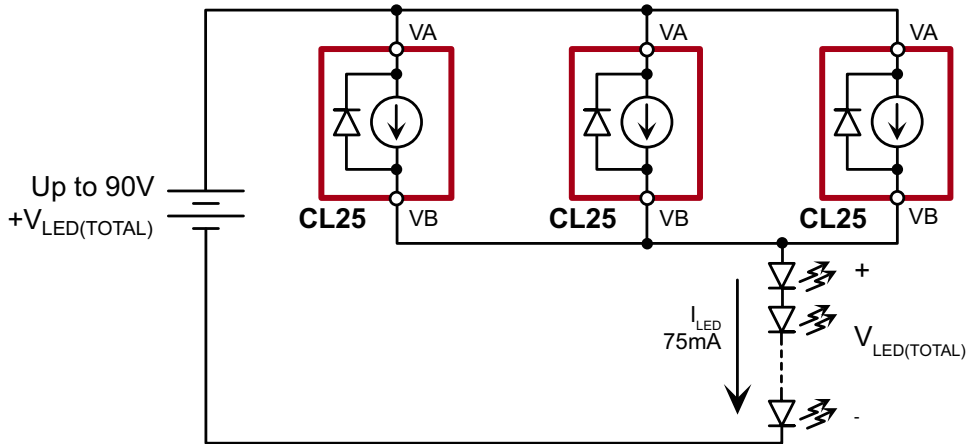

CL25 for Higher Current

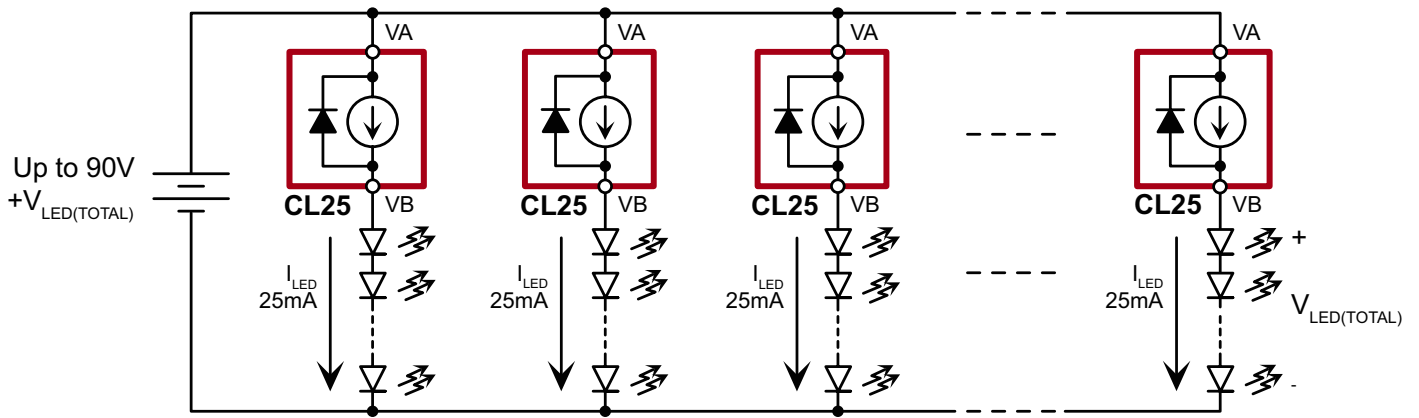

3-Lead TO-92 Package Outline (N3)

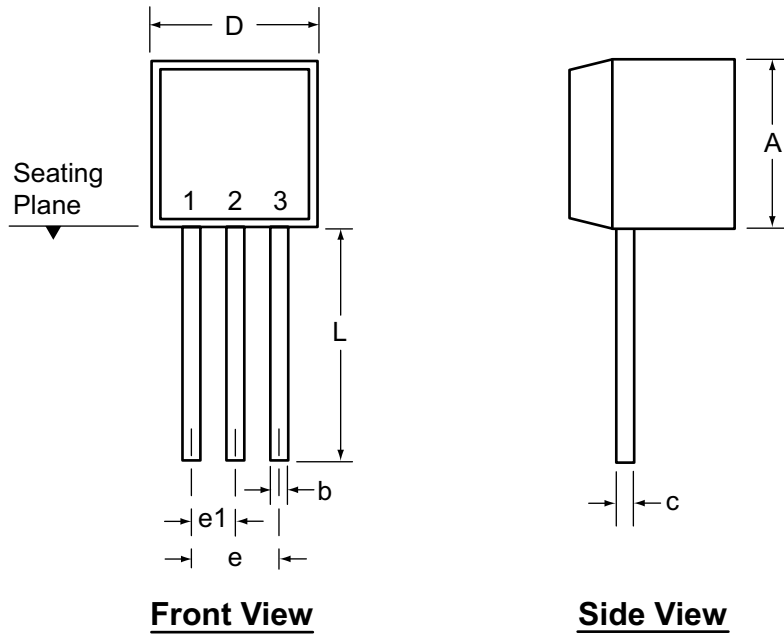

Symbol		A	b	c	D	E	E1	e	e1	L
Dimensions (inches)	MIN	.170	.014 [†]	.014 [†]	.175	.125	.080	.095	.045	.500
	NOM	-	-	-	-	-	-	-	-	-
	MAX	.210	.022 [†]	.022 [†]	.205	.165	.105	.105	.055	.610*

JEDEC Registration TO-92.

* This dimension is not specified in the JEDEC drawing.

† This dimension differs from the JEDEC drawing.

Drawings not to scale.

Supertex Doc.#: DSPD-3TO92N3, Version E041009.

3-Lead TO-243AA (SOT-89) Package Outline (N8)

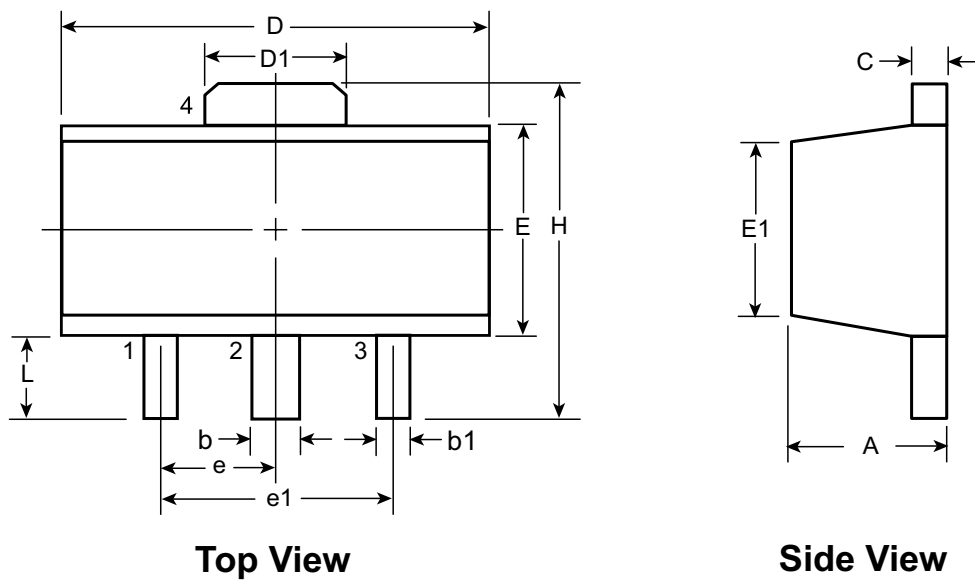

Symbol		A	b	b1	C	D	D1	E	E1	e	e1	H	L		
Dimensions (mm)	MIN	1.40	0.44	0.36	0.35	4.40	1.62	2.29	2.00 [†]	1.50 BSC	3.00 BSC	3.94	0.73 [†]		
	NOM	-	-	-	-	-	-	-	-			-	-	-	-
	MAX	1.60	0.56	0.48	0.44	4.60	1.83	2.60	2.29			-	-	4.25	1.20

JEDEC Registration TO-243, Variation AA, Issue C, July 1986.

[†] This dimension differs from the JEDEC drawing

Drawings not to scale.

Supertex Doc. #: DSPD-3TO243AAN8, Version F111010.

Supertex inc. does not recommend the use of its products in life support applications, and will not knowingly sell them for use in such applications unless it receives an adequate "product liability indemnification insurance agreement." **Supertex inc.** does not assume responsibility for use of devices described, and limits its liability to the replacement of the devices determined defective due to workmanship. No responsibility is assumed for possible omissions and inaccuracies. Circuitry and specifications are subject to change without notice. For the latest product specifications refer to the **Supertex inc.** (website: <http://www.supertex.com>)

X-ON Electronics

Largest Supplier of Electrical and Electronic Components

Click to view similar products for [LED Lighting Drivers](#) category:

Click to view products by [Supertex](#) manufacturer:

Other Similar products are found below :

[LV5235V-MPB-H](#) [MB39C602PNF-G-JNEFE1](#) [MIC2871YMK-T5](#) [AL1676-10BS7-13](#) [AL1676-20AS7-13](#) [AP5726WUG-7](#) [MX877RTR](#)
[ICL8201](#) [IS31BL3228B-UTLS2-TR](#) [IS31BL3506B-TTLS2-TR](#) [AL3157F-7](#) [AP5725FDCG-7](#) [AP5726FDCG-7](#) [LV52204MTTBG](#)
[AP5725WUG-7](#) [STP4CMPQTR](#) [NCL30086BDR2G](#) [CAT4004BHU2-GT3](#) [LV52207AXA-VH](#) [AP1694AS-13](#) [TLE4242EJ](#) [AS3688](#)
[IS31LT3172-GRLS4-TR](#) [TLD2311EL](#) [KTD2694EDQ-TR](#) [KTZ8864EJAA-TR](#) [IS32LT3174-GRLA3-TR](#) [ZXLD1374QESTTC](#) [MP2488DN-](#)
[LF-Z](#) [NLM0010XTSA1](#) [AL1676-20BS7-13](#) [MPQ7220GF-AEC1-P](#) [MPQ7220GR-AEC1-P](#) [MPQ4425BGJ-AEC1-P](#) [MPQ7220GF-AEC1-Z](#)
[MPQ7220GR-AEC1-Z](#) [MPQ4425BGJ-AEC1-Z](#) [IS31FL3737B-QFLS4-TR](#) [IS31FL3239-QFLS4-TR](#) [KTD2058EUAC-TR](#) [KTD2037EWE-TR](#)
[DIO5662ST6](#) [IS31BL3508A-TTLS2-TR](#) [MAX20052CATC/V+](#) [MAX25606AUP/V+](#) [BD6586MUV-E2](#) [BD9206EFV-E2](#) [BD9416FS-E2](#)
[LYT4227E](#) [LYT6079C-TL](#)