

## Linear, Fixed Constant Current LED Driver

### Features

- ▶ 25mA  $\pm$ 10% constant current drive
- ▶ 1.0V dropout
- ▶ 90V rating for transient immunity
- ▶ Temperature compensated
- ▶ 4.75 - 90V supply range

### Applications

- ▶ Specialty lighting
- ▶ Low voltage signage

### General Description

The CL525 is a fixed, linear current regulator designed for driving LEDs at 25mA. With a maximum rating of 90V, it is able to withstand transients without the need for additional transient protection circuitry. It is ideally suited for applications employing single or multiple LEDs.

The minimum dropout voltage of 1.0V accommodates extra LEDs, permits lower supply voltages, and provides more efficient operation.

The CL525 is offered in TO-252(D-PAK) and TO-92 packages.

### Typical Application Circuit

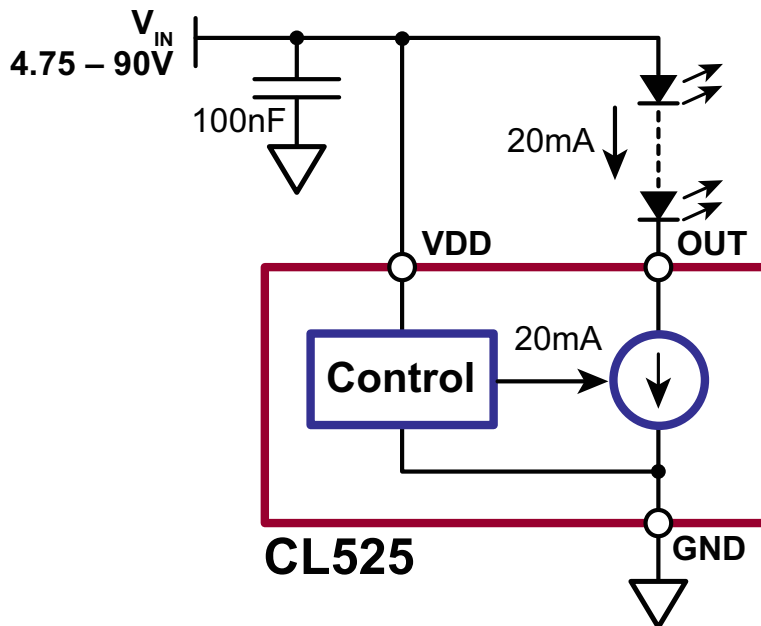

## Ordering Information

Part Number	Package Options	Packing
CL525K4-G	TO-252 (D-PAK)	2000/Reel
CL525N3-G	TO-92	1000/Bag
CL525N3-G P002	TO-92	2000/Reel
CL525N3-G P003	TO-92	2000/Reel
CL525N3-G P005	TO-92	2000/Reel
CL525N3-G P013	TO-92	2000/Reel
CL525N3-G P014	TO-92	2000/Reel

-G denotes a lead (Pb)-free / RoHS compliant package

Refer to 'P0xx' Tape & Reel Specs for P002, P003, P005, P013, and P014 TO-92 Taping Specifications and Winding Styles

## Absolute Maximum Ratings

Parameter	Value
Supply voltage, $V_{DD}$	-0.5V to +100V
Output voltage, $V_{OUT}$	-0.5V to +100V
Operating junction temperature	-40°C to +125°C
Storage temperature	-65°C to +150°C

Absolute Maximum Ratings are those values beyond which damage to the device may occur. Functional operation under these conditions is not implied. Continuous operation of the device at the absolute rating level may affect device reliability. All voltages are referenced to device ground..

## Typical Thermal Resistance

Package	$\theta_{ja}$
TO-252 (D-PAK)	81°C/W*
TO-92	132°C/W*

### Notes:

1. Thermal considerations may limit voltage to less than 90V.

\* Mounted on JEDEC test PCB (2s 2p)

## Recommended Operating Conditions (all voltages with respect to GND pin)

Sym	Parameter	Min	Typ	Max	Units	Conditions
$V_{DD}$	Supply voltage	4.75	-	90	V	---
$V_{OUT}$	Voltage at OUT pin <sup>1</sup>	1.0	-	90	V	---
$T_J$	Junction temperature	-40	-	125	°C	---
$C_{DD}$	$V_{DD}$ bypass capacitor	100	-	-	nF	---

## Pin Configurations

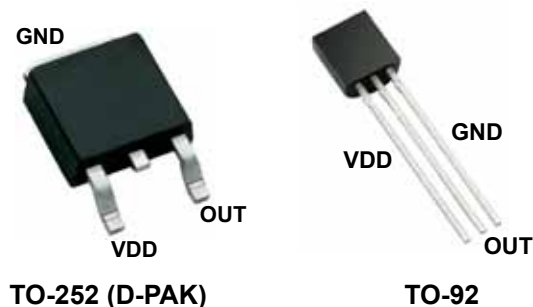

## Product Marking

Si YYWW  
CL525K4  
LLLLLLL

YY = Year Sealed  
WW = Week Sealed  
L = Lot Number  
\_\_\_\_\_ = "Green" Packaging

Package may or may not include the following marks: Si or 

**TO-252 (D-PAK)**

SiCL  
5 2 5  
YYWW

YY = Year Sealed  
WW = Week Sealed  
\_\_\_\_\_ = "Green" Packaging

Package may or may not include the following marks: Si or 

**TO-92**

## Electrical Characteristics

(Over recommended operating conditions.  $T_A = 25^\circ\text{C}$  unless otherwise specified. All voltages with respect to GND pin)

Sym	Parameter	Min	Typ	Max	Units	Conditions
$I_{DD}$	Current into VDD pin	-	-	1.0	mA	---
$I_{OUT}$	Current into OUT pin	22.5	25	27.5	mA	$1.0\text{V} < V_{OUT} < 90\text{V}$
		-	-	27.5		$V_{OUT} < 1.0\text{V}$
$I_{OUT(OFF)}$	Current into OUT pin with VDD pin open	-	-	10	$\mu\text{A}$	$V_{DD} = \text{open}$
$V_{DD(OFF)}$	Voltage at VDD to shut off LED current	-	-	1.0	V	$I_{OUT} < 10\mu\text{A}$
$t_{ON}$	VDD applied on time	-	-	100	$\mu\text{s}$	---
$t_{OFF}$	VDD removed off time	-	-	100	$\mu\text{s}$	---

## Temperature Effects

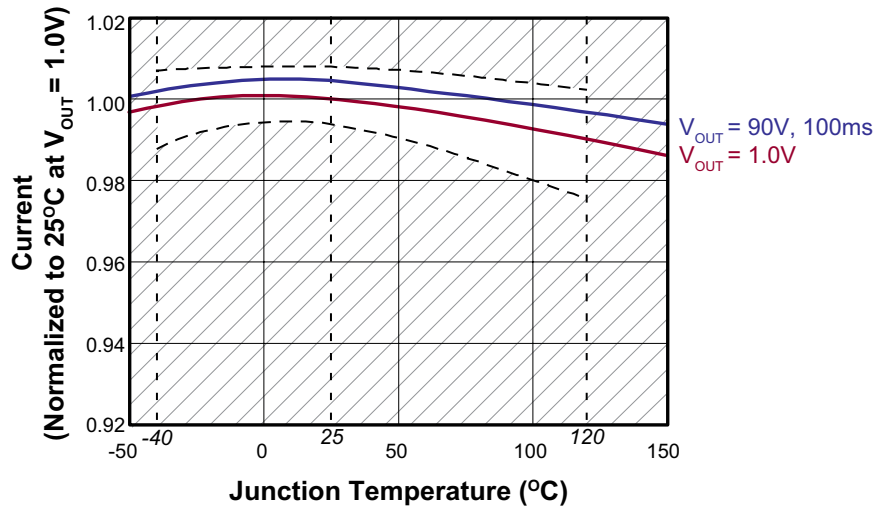

## Application Circuits

### Switched LED

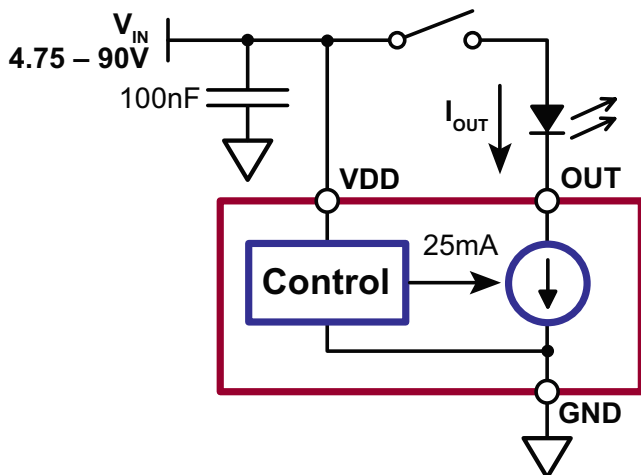

### Seperate LED Supply

( $V_{OUT}$  may be higher or lower than  $V_{DD}$ )

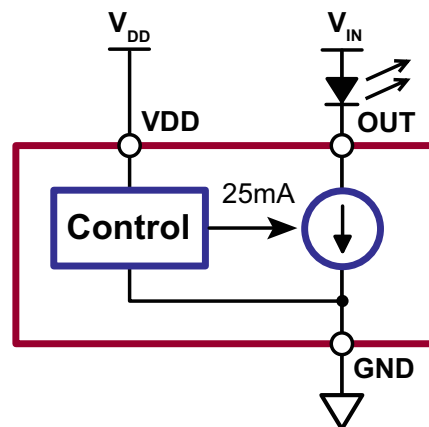

Application Circuits (cont.)

Ground Referenced LEDs

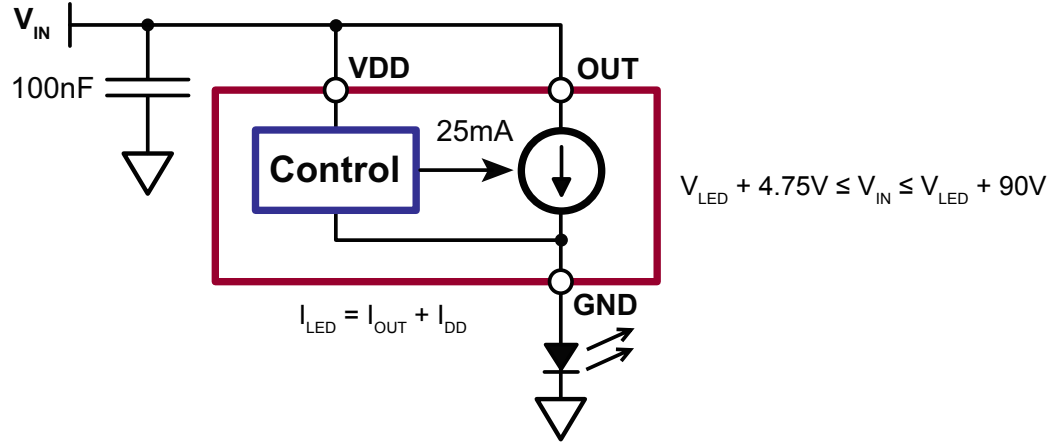

Pin Description

Pin #		Name	Description
TO-252 D-PAK (K4)	TO-92 (N3)		
1	1	VDD	Supply voltage for the CL525. Bypass locally with a 100nF capacitor to ground.
3	2	OUT	Constant current output (sink).
4	3	GND	Circuit common.

### 3-Lead TO-252 D-PAK Package Outline (K4)

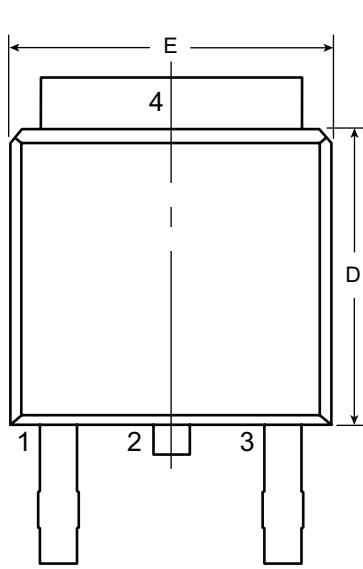

**Front View**

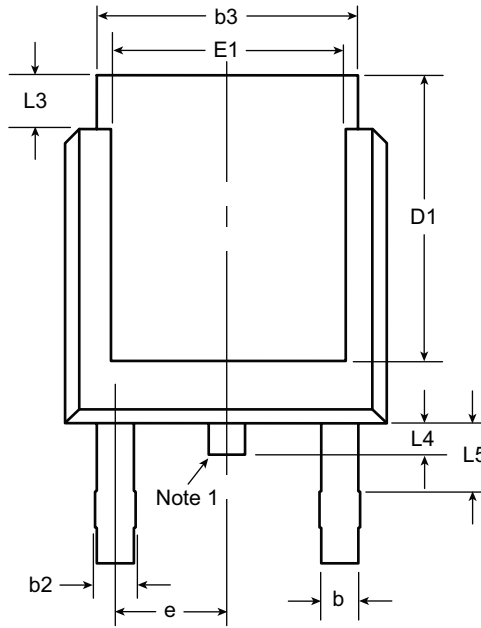

**Rear View**

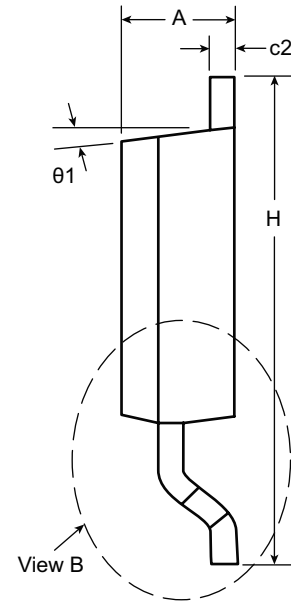

**Side View**

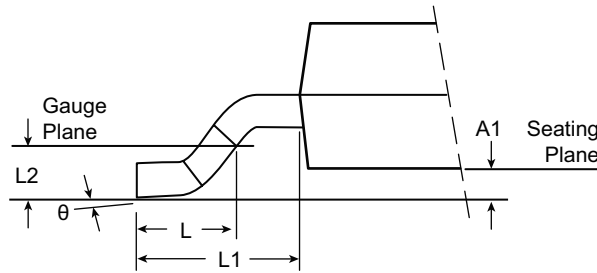

**View B**

**Note:**

1. Although 4 terminal locations are shown, only 3 are functional. Lead number 2 was removed.

Symbol	A	A1	b	b2	b3	c2	D	D1	E	E1	e	H	L	L1	L2	L3	L4	L5	θ	θ1		
Dimension (inches)	MIN	.086	.000*	.025	.030	.195	.018	.235	.205	.250	.170	.370	.055	.108 REF	.020 BSC	.035	.025*	.045	0°	0°		
	NOM	-	-	-	-	-	-	.240	-	-	.090 BSC	-	.060			-	-	-	-	-	-	-
	MAX	.094	.005	.035	.045	.215	.035	.245	.217*	.265	.182*	.410	.070			.050	.040	.060	10°	15°		

JEDEC Registration TO-252, Variation AA, Issue E, June 2004.

\* This dimension is not specified in the JEDEC drawing.

**Drawings not to scale.**

**Supertex Doc. #: DSPD-3TO252K4, Version E041309.**

### 3-Lead TO-92 Package Outline (N3)

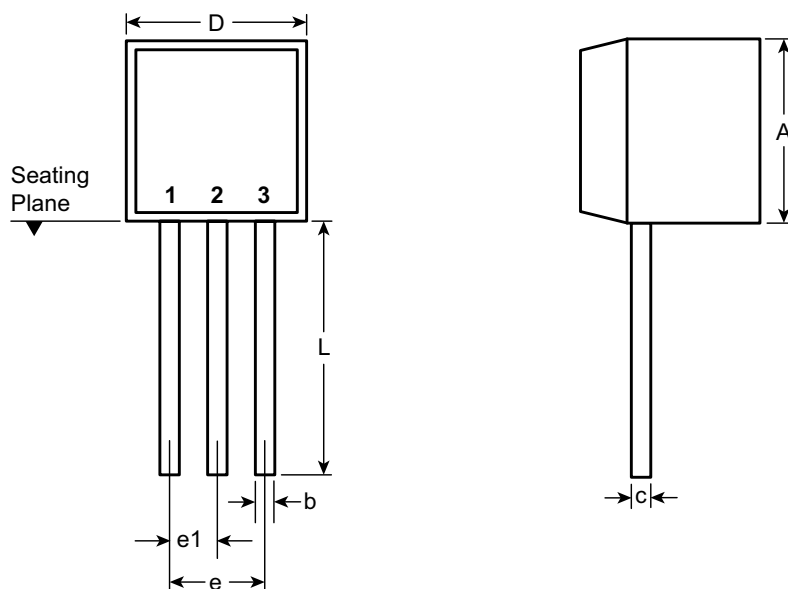

**Front View**

**Side View**

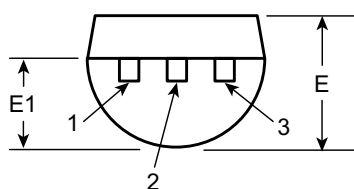

**Bottom View**

Symbol		A	b	c	D	E	E1	e	e1	L
Dimensions (inches)	MIN	.170	.014 <sup>†</sup>	.014 <sup>†</sup>	.175	.125	.080	.095	.045	.500
	NOM	-	-	-	-	-	-	-	-	-
	MAX	.210	.022 <sup>†</sup>	.022 <sup>†</sup>	.205	.165	.105	.105	.055	.610*

JEDEC Registration TO-92.

\* This dimension is not specified in the JEDEC drawing.

† This dimension differs from the JEDEC drawing.

**Drawings not to scale.**

**Supertex Doc.#:** DSPD-3TO92N3, Version E041009.

(The package drawing(s) in this data sheet may not reflect the most current specifications. For the latest package outline information go to <http://www.supertex.com/packaging.html>.)

**Supertex inc.** does not recommend the use of its products in life support applications, and will not knowingly sell them for use in such applications unless it receives an adequate "product liability indemnification insurance agreement." **Supertex inc.** does not assume responsibility for use of devices described, and limits its liability to the replacement of the devices determined defective due to workmanship. No responsibility is assumed for possible omissions and inaccuracies. Circuitry and specifications are subject to change without notice. For the latest product specifications refer to the **Supertex inc.** (website: <http://www.supertex.com>)

## X-ON Electronics

Largest Supplier of Electrical and Electronic Components

*Click to view similar products for [LED Lighting Drivers](#) category:*

*Click to view products by [Supertex](#) manufacturer:*

Other Similar products are found below :

[LV5235V-MPB-H](#) [MB39C602PNF-G-JNEFE1](#) [MIC2871YMK-T5](#) [AL1676-10BS7-13](#) [AL1676-20AS7-13](#) [AP5726WUG-7](#) [MX877RTR](#)  
[ICL8201](#) [IS31BL3228B-UTLS2-TR](#) [IS31BL3506B-TTLS2-TR](#) [AL3157F-7](#) [AP5725FDCG-7](#) [AP5726FDCG-7](#) [LV52204MTTBG](#)  
[AP5725WUG-7](#) [STP4CMPQTR](#) [NCL30086BDR2G](#) [CAT4004BHU2-GT3](#) [LV52207AXA-VH](#) [AP1694AS-13](#) [TLE4242EJ](#) [AS3688](#)  
[IS31LT3172-GRLS4-TR](#) [TLD2311EL](#) [KTD2694EDQ-TR](#) [KTZ8864EJAA-TR](#) [IS32LT3174-GRLA3-TR](#) [ZXLD1374QESTTC](#) [MP2488DN-](#)  
[LF-Z](#) [NLM0010XTSA1](#) [AL1676-20BS7-13](#) [MPQ7220GF-AEC1-P](#) [MPQ4425BGJ-AEC1-P](#) [MPQ7220GF-AEC1-Z](#) [MPQ4425BGJ-AEC1-Z](#)  
[IS31FL3737B-QFLS4-TR](#) [IS31FL3239-QFLS4-TR](#) [KTD2058EUAC-TR](#) [KTD2037EWE-TR](#) [DIO5662ST6](#) [IS31BL3508A-TTLS2-TR](#)  
[MAX20052CATC/V+](#) [MAX25606AUP/V+](#) [BD6586MUV-E2](#) [BD9206EFV-E2](#) [BD9416FS-E2](#) [LYT4227E](#) [LYT6079C-TL](#) [MP3394SGF-P](#)  
[MP4689AGN-P](#)